

SERIES 76 and 78

DPDT

FEATURES

- Raised and Recessed Rocker, and Toggle Actuated Styles
- DPDT with Common Poles, or DPDT with 4 Isolated Circuits
- Spring and Ball Contact
- Top Tape Seal Option for Most Styles

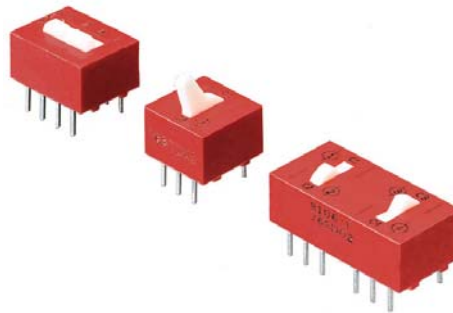

DIMENSIONS: Series 76 In inches (and millimeters)

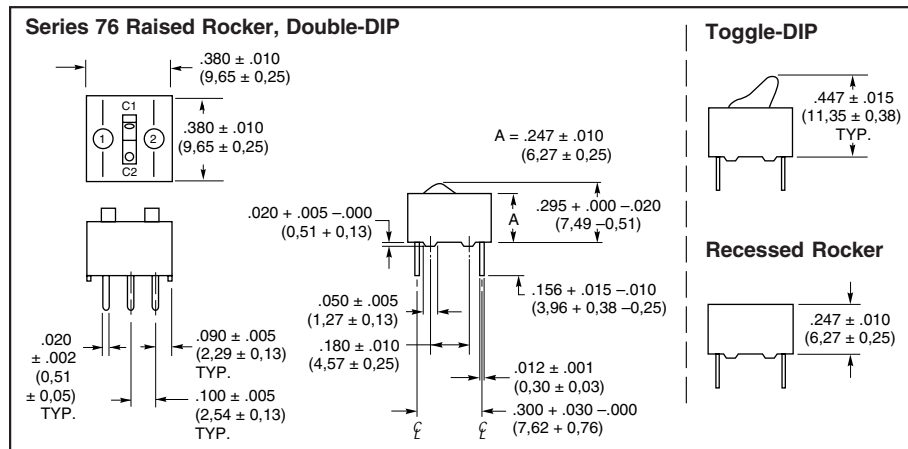

CIRCUITRY: Series 76

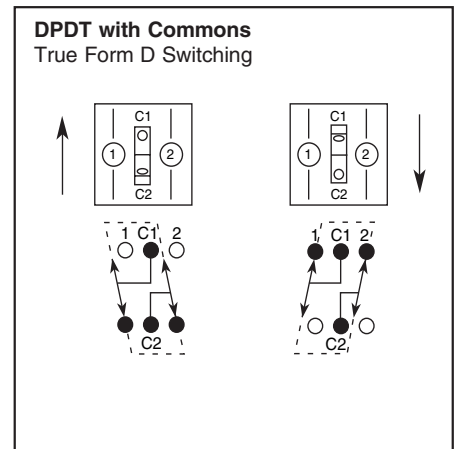

DIMENSIONS: Series 78 In inches (and millimeters)

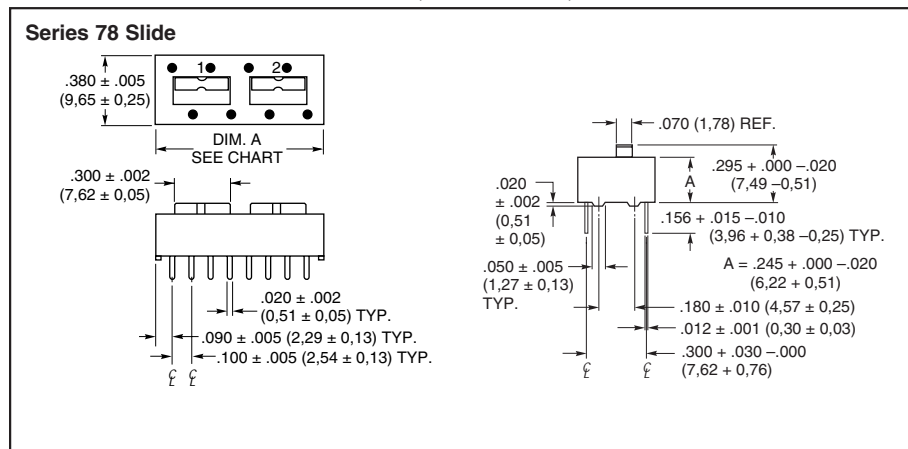

CIRCUITRY: Series 78

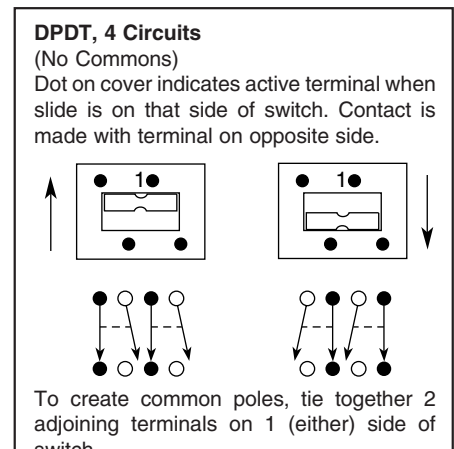

ORDERING INFORMATION

| Circuitry | No./ Positions | Length Inches | Length Metric | No./ Tube | Raised Type* | Recessed Rockers* | Toggle-DIP* |
|--------------|----------------|---------------|---------------|-----------|--------------|-------------------|-------------|
| DPDT Form D | 1 | 0.380" | 9,7mm | 27 | 76SD01T | 76RSD01T | 76STD01T |
| | 2 | 0.780" | 19,8mm | 13 | 76SD02T | 76RSD02T | 76STD02T |
| DPDT 4 Circ. | 1 | 0.480" | 12,2mm | 21 | 78K01T | — | — |
| | 2 | 0.880" | 22,4mm | 12 | 78K02T | — | — |

Available from your local Grayhill Distributor. For prices and discounts, contact a local Sales Office, an authorized local Distributor or Grayhill.

A top tape seal is required for switches that are machine soldered or heavily cleaned after hand soldering. To order top seal versions, add "S" before the "T" in the Grayhill part number. Not available on Toggle-DIP.

SPECIFICATIONS: Standard Styles

| Ratings | 76 | 78 | 90B |
|--|-----------------|-----------------|-----------------|
| Mechanical Life: Operations per switch position | 2,000 | 2,000 | 2,000 |
| Make-and-break Current Rating: Operations per switch position at these resistive loads | | | |
| 1 mA, 5 Vdc; 50 mA, 30 Vdc; or 150 mA, 30 Vdc: | 2,000 | 2,000 | — |
| 10 mA, 30 Vdc; or 10 mA, 50 mVdc: | — | — | 2,000 |
| 10 mA, 50 mVdc; or 25 mA, 24 Vdc; or 100 mA, 6 Vdc: | — | — | 2,000 |
| Contact Resistance: Initially: | ≤ 30 mΩ | ≤ 30 mΩ | ≤ 20 mΩ |
| After life, at 10 mA, 50 mVdc, open circuit: | ≤ 100 mΩ | ≤ 100 mΩ | ≤ 100 mΩ |
| Insulation Resistance: | | | |
| Minimum, at 100 Vdc between adjacent closed contacts and also across open switch contacts | | | |
| Initially (Mohms): | 5,000 | 5,000 | 5,000 |
| After life (Mohms): | 1,000 | 1,000 | 1,000 |
| Dielectric Strength: Minimum voltage (AC, RMS) measured between adjacent closed contacts and also across open switch contacts. | | | |
| Initially: | 750 V | 750 V | 500 V |
| After life: | 500 V | 500 V | 500 V |
| Current Carry Rating: Maximum rise of 20°C | 5 A | 4 A | 3 A |
| Switch Capacitance: At 1 megahertz | 2 pF | 2 pF | 2 pF |
| Operating Temperature Range: | -40°C to + 85°C | -40°C to + 85°C | -40°C to + 85°C |
| Storage Temperature Range: | -55°C to + 85°C | -55°C to + 85°C | -55°C to + 85°C |

Mechanical Ratings

Vibration Resistance: Per Method 204, Test Condition B, 1 mS opening (10 mS allowed)

Mechanical Shock: Per Method 213, Test Condition A. 1 mS opening (10 mS allowed)

Thermal Shock Resistance: Per specification; no failures; passes contact resistance.

Terminal Strength: Per specification

Thermal Aging: 1,000 hours at 85°C; no failures.

Environmental Ratings

Meets all requirements of MIL- S-83504.**

Where Grayhill performance is superior, the MIL spec is listed in parentheses.

Moisture Resistance: Per MIL-STD-202, Method 106.

Soldering Information

Series 90 MIDIP and Series 76 recessed rocker (76RSB style) sealed switches have been tested to EIA Standard RS-448-2. Similar performance can be expected from other sealed Series 76 and 78 DIP switches.

Solderability: Per MIL-STD-202, Method 208

Resistance to Soldering Heat: 76RSB: Passes EIA Standard using two, four, and six second soldering time. 90: Per MIL-S-83504, six second test.

Fluxing: Per EIA RS-448-2 with flux touching switch body.

Cleaning: 76, 78 and 90 series tape sealed products: Passes immersion test using water/detergent. Acceptable solutions include 1-1-1 trichlorethane, freon, (TF, TE, or TMS), isopropyl alcohol, detergent (140°F maximum). Terpene acceptable for Series 90 only. Solutions which are not recommended include acetone, methylene chloride, freon TMC.

Materials and Finishes

Shorting Member (Ball): Brass, gold-plated over nickel barrier.

Base Contacts: Copper alloy, gold-plated over nickel barrier.

Terminals: Copper alloy, matte tin plated over nickel barrier.

Non-Conductive Parts: Thermoplastic (UL94V-O)

Potting Material: Epoxy, 76,78 only.

Protective Cover: 76,78, only-Polycarbonate.

Tape Seal:

76, 78: Polyester film

90: Polyimide film

Tape Seal Integrity: Passes gross leak test using 125°C flourinert for 20 seconds minimum. Reference MIL-STD-202, Method 112.

Recommended Soldering Conditions:

Reflow Soldering Profile:

(260°C Peak Temperature)

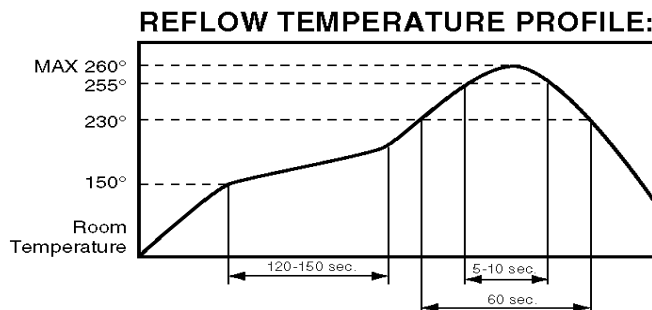

WAVE SOLDERING: 260°C maximum solder temperature for 5 seconds max.

** Note: 100% matte tin terminal plating does not meet MIL-S-83504 for lead content.