

Double channel high-side solid state relay

Features

Type	$R_{DS(on)}$	I_{OUT}	V_{CC}
VND830ASP-E	60 m Ω	6 A ⁽¹⁾	36 V ⁽¹⁾

1. Per channel

- ECOPACK®: lead free and RoHS compliant
- Automotive Grade: compliance with AEC guidelines
- Very low standby current
- CMOS compatible input
- Proportional load current sense
- Current sense disable
- Thermal shutdown protection and diagnosis
- Undervoltage shutdown
- Overvoltage clamp
- Load current limitation

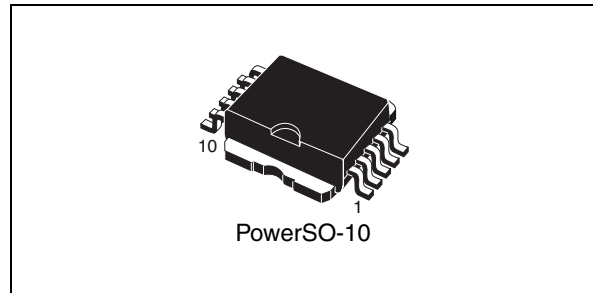

Description

The VND830ASP-E is a monolithic device made using STMicroelectronics™ VIPower™ M0-3 technology. It is intended for driving any kind of load with one side connected to ground. Active V_{CC} pin voltage clamp protects the device against low energy spikes (see ISO7637 transient compatibility table).

This device has two channels in high-side configuration; each channel has an analog sense output on which the sensing current is proportional (according to a known ratio) to the corresponding load current.

Built-in thermal shutdown and outputs current limitation protect the chip from overtemperature and short circuit. Device turns-off in case of ground pin disconnections.

Table 1. Device summary

Package	Order codes	
	Tube	Tape and reel
Power-SO-10™	VND830ASP-E	VND830ASPTR-E

Contents

1	Block diagram and pin description	5
2	Electrical specifications	6
2.1	Absolute maximum ratings	6
2.2	Thermal data	7
2.3	Electrical characteristics	8
2.4	Electrical characteristics curves	15
3	Application information	17
3.1	GND protection network against reverse battery	17
3.1.1	Solution 1: resistor in the ground line (RGND only)	17
3.1.2	Solution 2: diode (DGND) in the ground line	18
3.2	Load dump protection	18
3.3	MCU I/Os protection	18
3.4	PowerSO-10 maximum demagnetization energy ($V_{CC} = 13.5\text{ V}$)	19
4	Package and PCB thermal data	20
4.1	PowerSO-10 thermal data	20
5	Package and packing information	23
5.1	ECOPACK [®] packages	23
5.2	PowerSO-10 mechanical data	23
5.3	PowerSO-10 packing information	25
6	Revision history	26

List of tables

Table 1.	Device summary	1
Table 2.	Absolute maximum ratings	6
Table 3.	Thermal data.	7
Table 4.	Power	8
Table 5.	Switching ($V_{CC} = 13\text{ V}$)	8
Table 6.	Logic input (channel 1, 2)	9
Table 7.	V_{CC} - output diode.	9
Table 8.	Protection	9
Table 9.	Current sense	10
Table 10.	Truth table (per each channel)	12
Table 11.	Electrical transient requirements on V_{CC} pin (part 1)	13
Table 12.	Electrical transient requirements on V_{CC} pin (part 2)	13
Table 13.	Electrical transient requirements on V_{CC} pin (part 3)	13
Table 14.	Thermal parameter	22
Table 15.	PowerSO-10 mechanical data	24
Table 16.	Document revision history	26

List of figures

Figure 1.	Block diagram	5
Figure 2.	Configuration diagram (top view)	5
Figure 3.	Current and voltage conventions	6
Figure 4.	Switching characteristics (resistive load $R_L = 6.5 \Omega$)	11
Figure 5.	I_{OUT}/I_{SENSE} versus I_{OUT}	11
Figure 6.	Waveforms	14
Figure 7.	Off-state output current	15
Figure 8.	High level input current	15
Figure 9.	Input clamp voltage	15
Figure 10.	Input high level	15
Figure 11.	Input low level	15
Figure 12.	Input hysteresis voltage	15
Figure 13.	Overshoot shutdown	16
Figure 14.	I_{LIM} vs T_{case}	16
Figure 15.	Turn-on voltage slope	16
Figure 16.	Turn-off voltage slope	16
Figure 17.	On-state resistance vs T_{case}	16
Figure 18.	On-state resistance vs V_{CC}	16
Figure 19.	Application schematic	17
Figure 20.	Maximum turn- off current versus load inductance ⁽¹⁾	19
Figure 21.	PowerSO-10 PC board ⁽¹⁾	20
Figure 22.	$R_{thj-amb}$ vs PCB copper area in open box free air condition	20
Figure 23.	PowerSO-10 thermal impedance junction ambient single pulse	21
Figure 24.	Thermal fitting model of a double channel HSD in PowerSO-10	21
Figure 25.	PowerSO-10 package dimensions	23
Figure 26.	PowerSO-10 suggested pad layout and tube shipment (no suffix)	25
Figure 27.	Tape and reel shipment (suffix "TR")	25

1 Block diagram and pin description

Figure 1. Block diagram

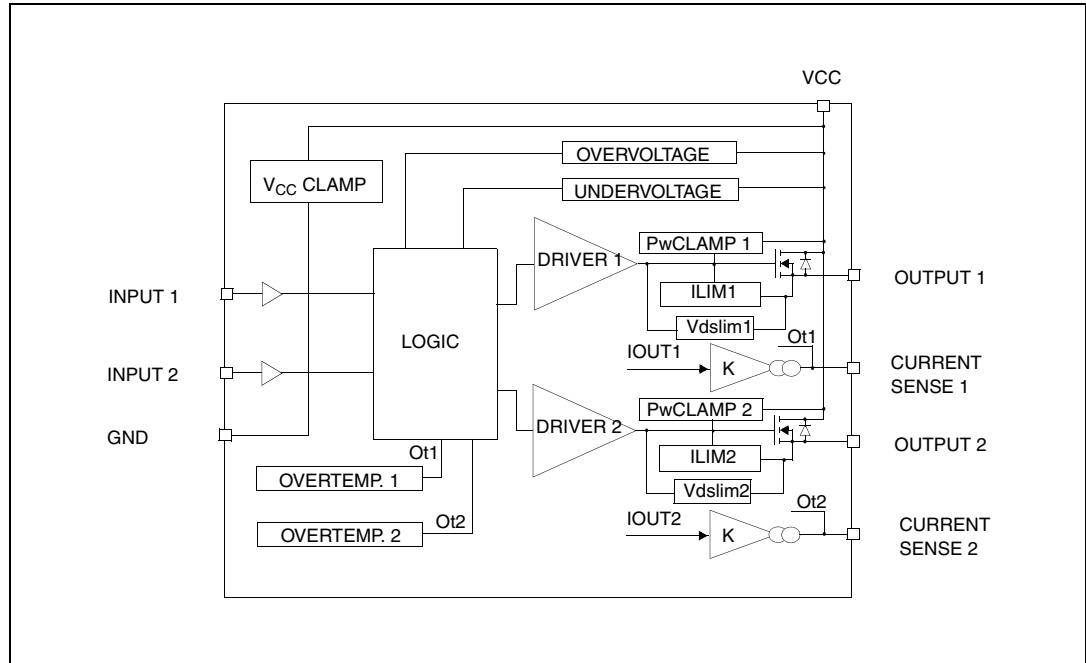
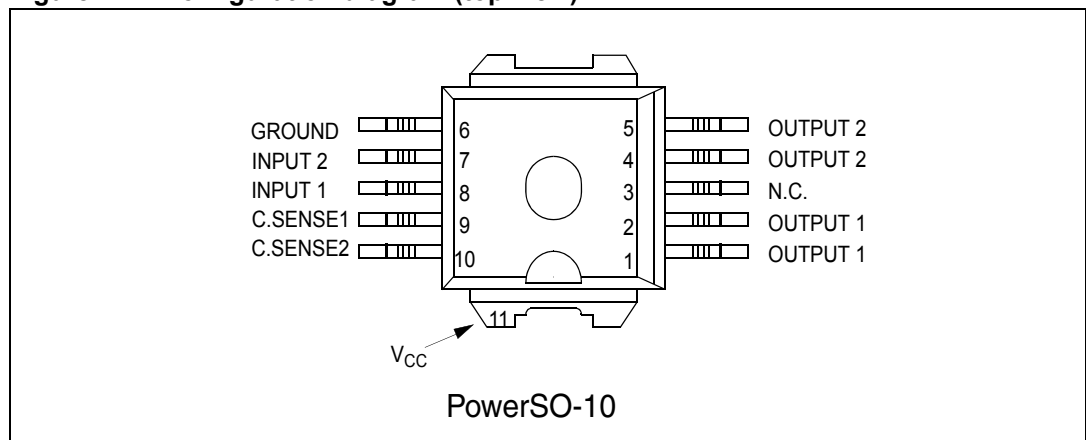
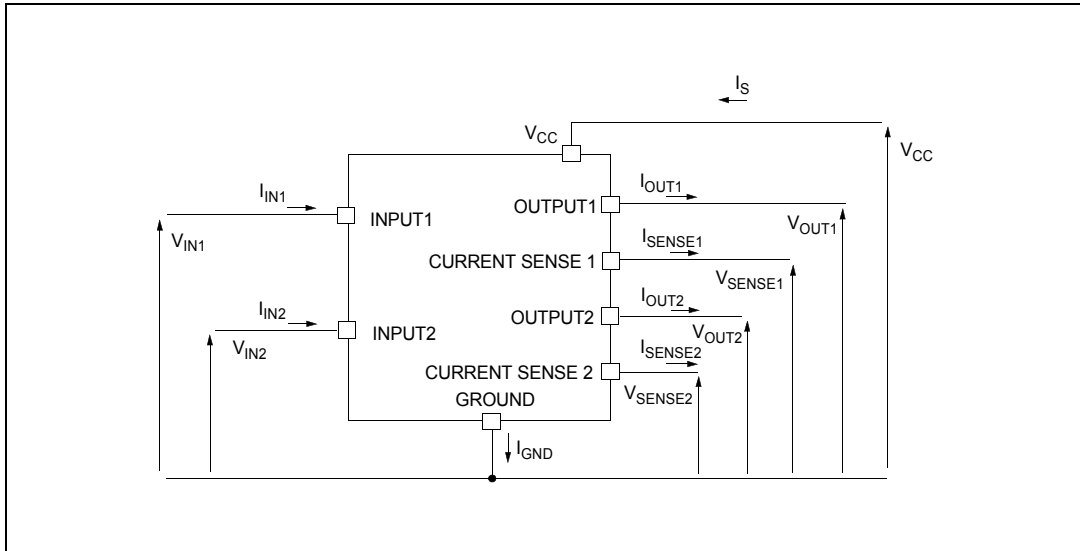

Figure 2. Configuration diagram (top view)



2 Electrical specifications

Figure 3. Current and voltage conventions



2.1 Absolute maximum ratings

Stressing the device above the rating listed in [Table 2](#) may cause permanent damage to the device. These are stress ratings only and operation of the device at these or any other conditions above those indicated in the operating sections of this specification is not implied. Exposure to absolute maximum rating conditions for extended periods may affect device reliability. Refer also to the STMicroelectronics sure program and other relevant quality document.

Table 2. Absolute maximum ratings

Symbol	Parameter	Value	Unit
V_{CC}	DC supply voltage	41	V
$-V_{CC}$	Reverse supply voltage	-0.3	V
$-I_{GND}$	DC reverse ground pin current	-200	mA
I_{OUT}	Output current	Internally limited	A
I_R	Reverse output current	-6	A
I_{IN}	Input current	+/- 10	mA
$V_{CSSENSE}$	Current sense maximum voltage	-3	V
		+15	V

Table 2. Absolute maximum ratings (continued)

Symbol	Parameter	Value	Unit
V _{ESD}	Electrostatic discharge (Human Body Model: R = 1.5 Ω; C = 100 pF)		
	– INPUT	4000	V
	– CURRENT SENSE	2000	V
	– OUTPUT	5000	V
	– V _{CC}	5000	V
E _{MAX}	Maximum switching energy (L = 1.8 mH; R _L = 0 Ω; V _{bat} = 13.5 V; T _{jstart} = 150 °C; I _L = 9 A)	100	mJ
P _{tot}	Power dissipation at T _C = 25 °C	74	W
T _j	Junction operating temperature	Internally limited	°C
T _C	Case operating temperature	-40 to 150	°C
T _{STG}	Storage temperature	-55 to 150	°C

2.2 Thermal data

Table 3. Thermal data

Symbol	Parameter	Value	Unit
R _{thj-case}	Thermal resistance junction-case	1.3	°C/W
R _{thj-amb}	Thermal resistance junction-ambient	51.2 ⁽¹⁾	°C/W

1. When mounted on a standard single sided FR-4 board with 0.5 cm² of Cu (at least 35 μm thick). Horizontal mounting and no artificial air flow.

2.3 Electrical characteristics

Values specified in this section are for $8\text{ V} < V_{CC} < 36\text{ V}$; $-40\text{ °C} < T_j < 150\text{ °C}$, unless otherwise specified. (Per each channel).

Table 4. Power

Symbol	Parameter	Test conditions	Min.	Typ.	Max.	Unit
V_{CC}	Operating supply voltage		5.5	13	36	V
V_{USD}	Undervoltage shutdown		3	4	5.5	V
V_{OV}	Overvoltage shutdown		36			V
R_{ON}	On-state resistance	$I_{OUT} = 2\text{ A}$; $T_j = 25\text{ °C}$			60	m Ω
		$I_{OUT} = 2\text{ A}$; $T_j = 150\text{ °C}$			120	m Ω
V_{clamp}	Clamp voltage	$I_{CC} = 20\text{ mA}^{(1)}$	41	48	55	V
I_S	Supply current	Off-state; $V_{CC} = 13\text{ V}$; $V_{IN} = V_{OUT} = 0\text{ V}$		12	40	μA
		Off-state; $V_{CC} = 13\text{ V}$; $V_{IN} = V_{OUT} = 0\text{ V}$; $T_j = 25\text{ °C}$		12	25	μA
		On-state; $V_{IN} = 5\text{ V}$; $V_{CC} = 13\text{ V}$; $I_{OUT} = 0\text{ A}$; $R_{SENSE} = 3.9\text{ k}\Omega$			7	mA
$I_{L(off1)}$	Off-state output current	$V_{IN} = V_{OUT} = 0\text{ V}$; $V_{CC} = 36\text{ V}$; $T_j = 125\text{ °C}$	0		50	μA
$I_{L(off2)}$	Off-state output current	$V_{IN} = 0\text{ V}$; $V_{OUT} = 3.5\text{ V}$	-75		0	μA
$I_{L(off3)}$	Off-state output current	$V_{IN} = V_{OUT} = 0\text{ V}$; $V_{CC} = 13\text{ V}$; $T_j = 125\text{ °C}$			5	μA
$I_{L(off4)}$	Off-state output current	$V_{IN} = V_{OUT} = 0\text{ V}$; $V_{CC} = 13\text{ V}$; $T_j = 25\text{ °C}$			3	μA

1. V_{clamp} and V_{OV} are correlated. Typical difference is 5 V.

Table 5. Switching ($V_{CC} = 13\text{ V}$)

Symbol	Parameter	Test conditions	Min	Typ	Max	Unit
$t_{d(on)}$	Turn-on delay time	$R_L = 6.5\ \Omega$ from V_{IN} rising edge to $V_{OUT} = 1.3\text{ V}$	-	30	-	μs
$t_{d(off)}$	Turn-on delay time	$R_L = 6.5\ \Omega$ from V_{IN} falling edge to $V_{OUT} = 11.7\text{ V}$	-	30	-	μs
$(dV_{OUT}/dt)_{on}$	Turn-on voltage slope	$R_L = 6.5\ \Omega$ from $V_{OUT} = 1.3\text{ V}$ to $V_{OUT} = 10.4\text{ V}$	-	See Figure 15	-	V/ μs
$(dV_{OUT}/dt)_{off}$	Turn-off voltage slope	$R_L = 6.5\ \Omega$ from $V_{OUT} = 11.7\text{ V}$ to $V_{OUT} = 1.3\text{ V}$	-	See Figure 16	-	V/ μs

Table 6. Logic input (channel 1, 2)

Symbol	Parameter	Test conditions	Min	Typ	Max	Unit
V_{IL}	Input low level voltage				1.25	V
I_{IL}	Low level input current	$V_{IN} = 1.25\text{ V}$	1			μA
V_{IH}	Input high level voltage		3.25			V
I_{IH}	High level input current	$V_{IN} = 3.25\text{ V}$			10	μA
$V_{I(hyst)}$	Input hysteresis voltage		0.5			V
V_{ICL}	Input clamp voltage	$I_{IN} = 1\text{ mA}$	6	6.8	8	V
		$I_{IN} = -1\text{ mA}$		-0.7		V

Table 7. V_{CC} - output diode

Symbol	Parameter	Test conditions	Min	Typ	Max	Unit
V_F	Forward on voltage	$-I_{OUT} = 2\text{ A}; T_j = 150\text{ }^\circ\text{C}$	-	-	0.6	V

Table 8. Protection

Symbol	Parameter	Test conditions	Min.	Typ.	Max.	Unit
I_{lim}	DC short circuit current	$V_{CC} = 13\text{ V}$	6	9	15	A
		$5.5\text{ V} < V_{CC} < 36\text{ V}$			15	A
T_{TSD}	Thermal shutdown temperature		150	175	200	$^\circ\text{C}$
T_R	Thermal reset temperature		135			$^\circ\text{C}$
T_{HYST}	Thermal hysteresis		7	15		$^\circ\text{C}$
V_{demag}	Turn-off output voltage clamp	$I_{OUT} = 2\text{ A}; V_{IN} = 0\text{ V}; L = 6\text{ mH}$	$V_{CC}-41$	$V_{CC}-48$	$V_{CC}-55$	V
V_{ON}	Output voltage drop limitation	$I_{OUT} = 10\text{ mA}$		50		mV

Table 9. Current sense⁽¹⁾

Symbol	Parameter	Test conditions	Min	Typ	Max	Unit
K_0	I_{OUT}/I_{SENSE}	I_{OUT1} or $I_{OUT2} = 0.05$ A; $V_{SENSE} = 0.5$ V; other channels open; $T_j = -40$ °C...150 °C	600	1300	2000	
K_1	I_{OUT}/I_{SENSE}	I_{OUT1} or $I_{OUT2} = 0.25$ A; $V_{SENSE} = 0.5$ V; other channels open; $T_j = -40$ °C...150 °C	1000	1400	1900	
dK_1/K_1	Current sense ratio drift	I_{OUT1} or $I_{OUT2} = 0.25$ A; $V_{SENSE} = 0.5$ V; other channels open; $T_j = -40$ °C...150 °C	-10		+10	%
K_2	I_{OUT}/I_{SENSE}	I_{OUT1} or $I_{OUT2} = 1.6$ A; $V_{SENSE} = 4$ V; other channels open; $T_j = -40$ °C $T_j = 25$ °C...150 °C	1280 1300	1500 1500	1800 1780	
dK_2/K_2	Current sense ratio drift	I_{OUT1} or $I_{OUT2} = 1.6$ A; $V_{SENSE} = 4$ V; other channels open; $T_j = -40$ °C...150 °C	-6		+6	%
K_3	I_{OUT}/I_{SENSE}	I_{OUT1} or $I_{OUT2} = 2.5$ A; $V_{SENSE} = 4$ V; other channels open; $T_j = -40$ °C $T_j = 25$ °C...150 °C	1280 1340	1500 1500	1680 1600	
dK_3/K_3	Current sense ratio drift	I_{OUT1} or $I_{OUT2} = 2.5$ A; $V_{SENSE} = 4$ V; other channels open; $T_j = -40$ °C...150 °C	-6		+6	%
I_{SENSE}	Analog sense leakage current	$V_{IN} = 0$ V; $I_{OUT} = 0$ A; $V_{SENSE} = 0$ V; $T_j = -40$ °C...150 °C	0		5	μA
		$V_{IN} = 5$ V; $I_{OUT} = 0$ A; $V_{SENSE} = 0$ V; $T_j = -40$ °C...150 °C	0		10	μA
V_{SENSE}	Max analog sense output voltage	$V_{CC} = 5.5$ V; $I_{OUT1,2} = 1.3$ A; $R_{SENSE} = 10$ kΩ	2			V
		$V_{CC} > 8$ V; $I_{OUT1,2} = 2.5$ A; $R_{SENSE} = 10$ kΩ	4			V
V_{SENSEH}	Sense voltage in overtemperature condition	$V_{CC} = 13$ V; $R_{SENSE} = 3.9$ kΩ		5.5		V
$R_{VSENSEH}$	Analog sense output impedance in overtemperature condition	$V_{CC} = 13$ V; $T_j > T_{TSD}$; All channels open		400		Ω
t_{DSENSE}	Current sense delay response	to 90% I_{SENSE} ⁽²⁾			500	μs

1. $9\text{ V} \leq V_{CC} \leq 16\text{ V}$ (see [Figure 4](#))

2. Current sense signal delay after positive input slope.
Sense pin doesn't have to be left floating.

Figure 4. Switching characteristics (resistive load $R_L = 6.5 \Omega$)

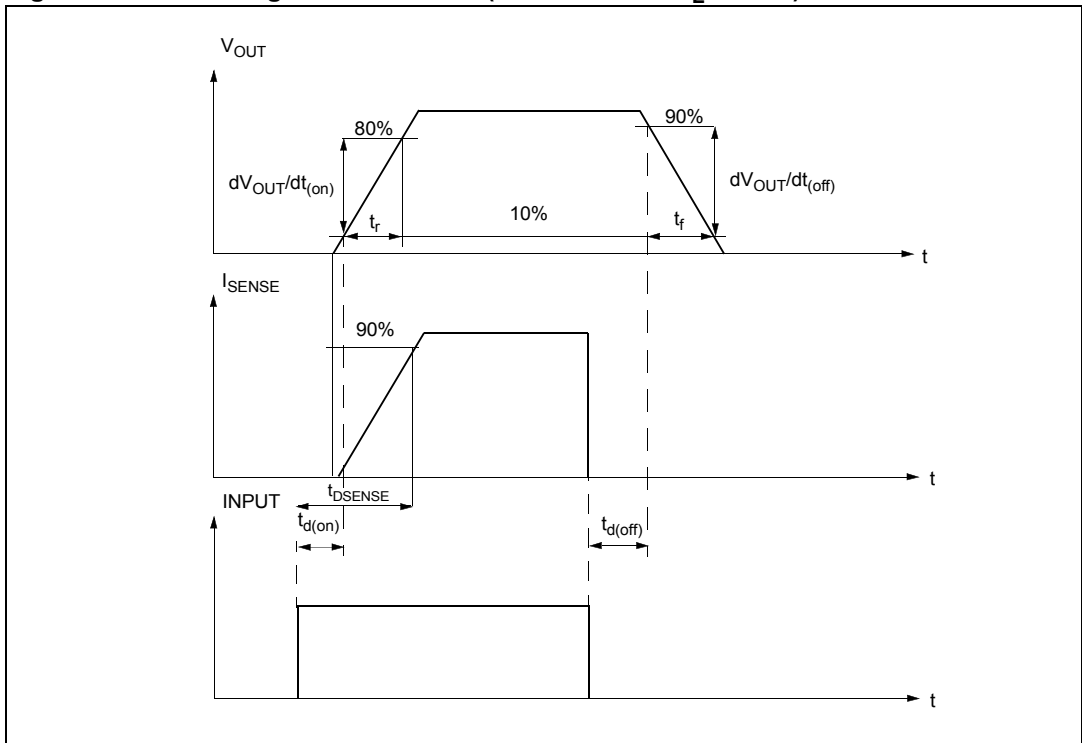

Figure 5. I_{OUT}/I_{SENSE} versus I_{OUT}

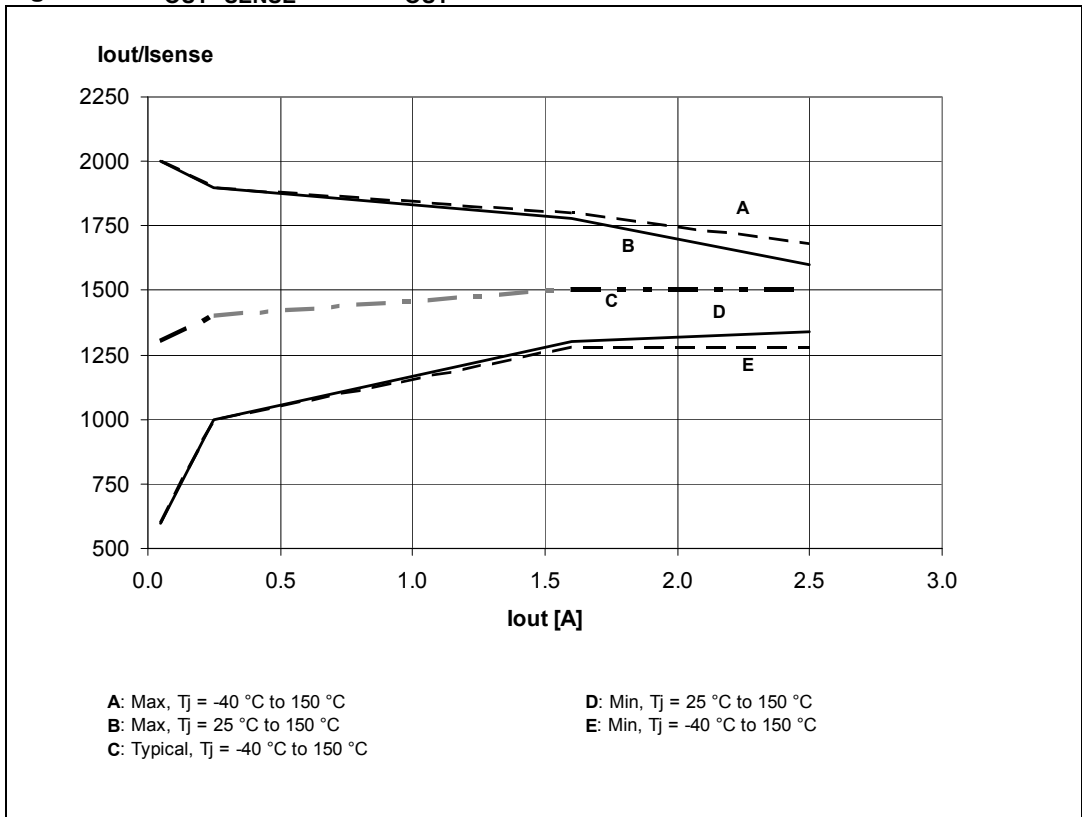

Table 10. Truth table (per each channel)

Conditions	Input	Output	Sense
Normal operation	L	L	0
	H	H	Nominal
Overtemperature	L	L	0
	H	L	V_{SENSEH}
Undervoltage	L	L	0
	H	L	0
Overvoltage	L	L	0
	H	L	0
Short circuit to GND	L	L	0
	H	L	$(T_j < T_{TSD})$ 0
	H	L	$(T_j > T_{TSD})$ V_{SENSEH}
Short circuit to V_{CC}	L	H	0
	H	H	< Nominal
Negative output voltage clamp	L	L	0

Table 11. Electrical transient requirements on V_{CC} pin (part 1)

ISO T/R 7637/1 test pulse	Test levels				Delays and impedance
	I	II	III	IV	
1	-25 V	-50 V	-75 V	-100 V	2 ms, 10 Ω
2	+25 V	+50 V	+75 V	+100 V	0.2 ms, 10 Ω
3a	-25 V	-50 V	-100 V	-150 V	0.1 μs, 50 Ω
3b	+25 V	+50 V	+75 V	+100 V	0.1 μs, 50 Ω
4	-4 V	-5 V	-6 V	-7 V	100 ms, 0.01 Ω
5	+26.5 V	+46.5 V	+66.5 V	+86.5 V	400 ms, 2 Ω

Table 12. Electrical transient requirements on V_{CC} pin (part 2)

ISO T/R 7637/1 Test pulse	Test levels results			
	I	II	III	IV
1	C	C	C	C
2	C	C	C	C
3a	C	C	C	C
3b	C	C	C	C
4	C	C	C	C
5	C	E	E	E

Table 13. Electrical transient requirements on V_{CC} pin (part 3)

Class	Contents
C	All functions of the device are performed as designed after exposure to disturbance.
E	One or more functions of the device is not performed as designed after exposure to disturbance and cannot be returned to proper operation without replacing the device.

Figure 6. Waveforms

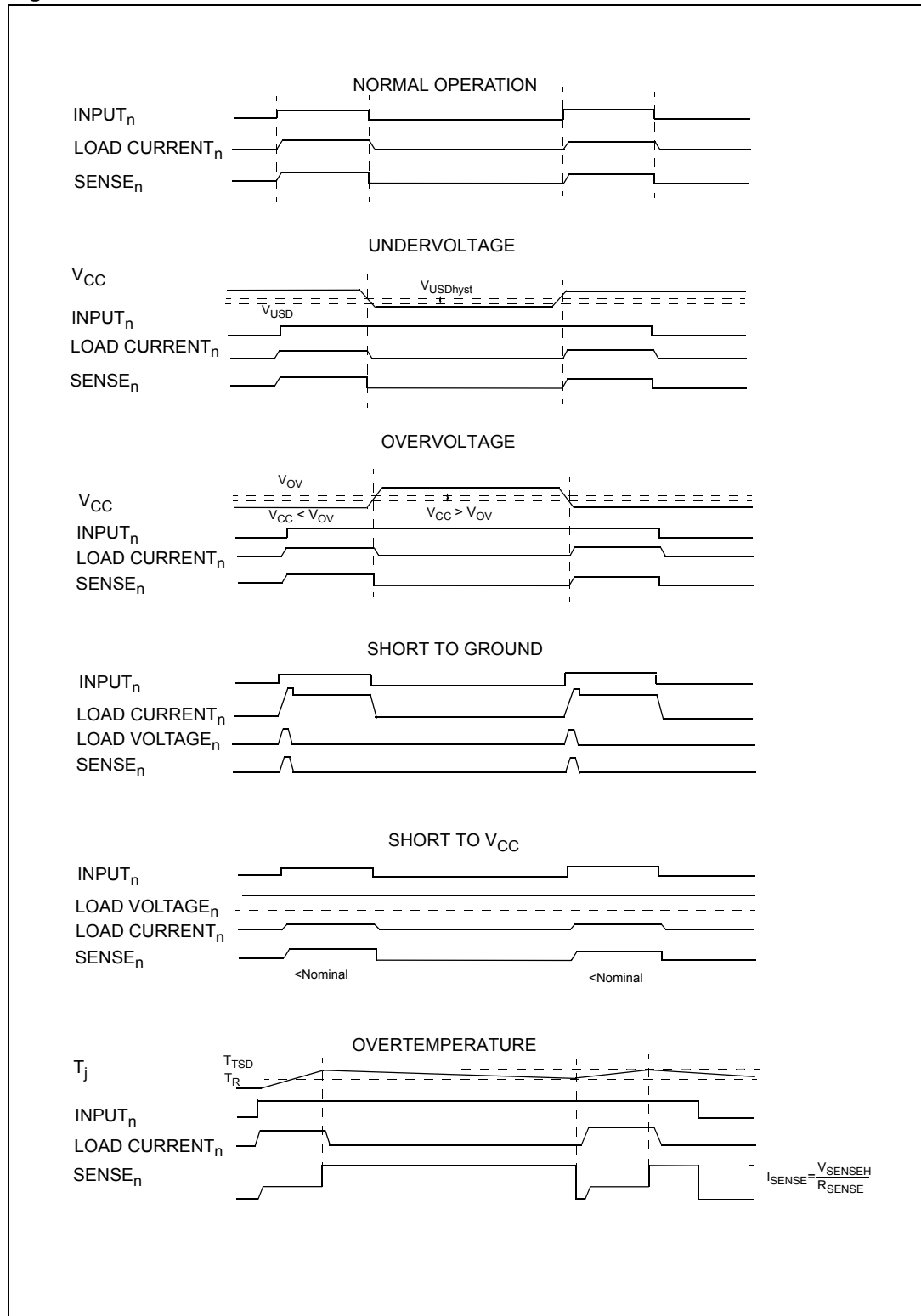

2.4 Electrical characteristics curves

Figure 7. Off-state output current

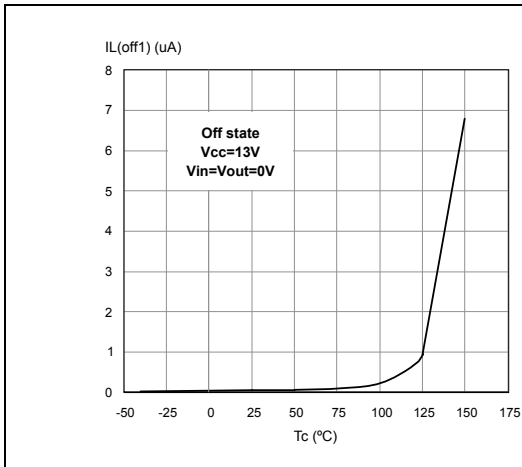

Figure 8. High level input current

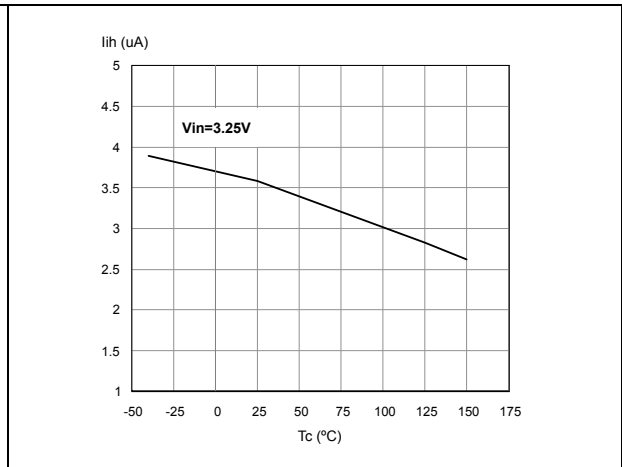

Figure 9. Input clamp voltage

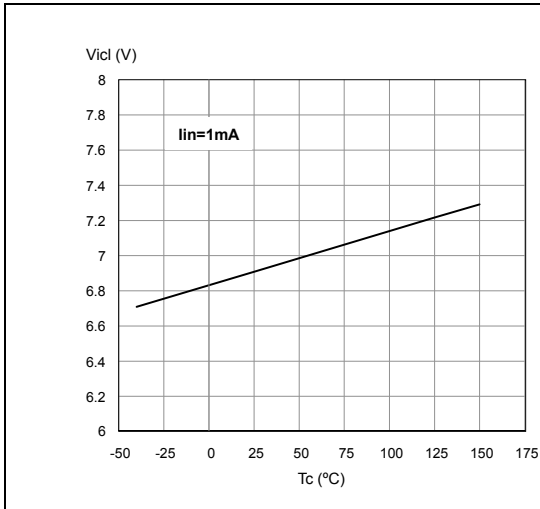

Figure 10. Input high level

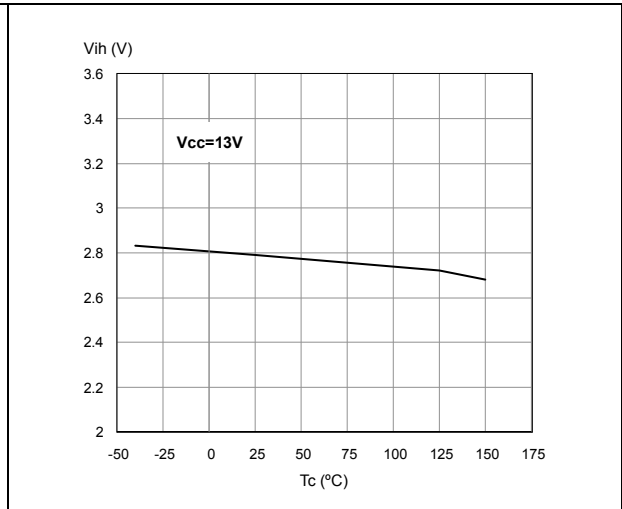

Figure 11. Input low level

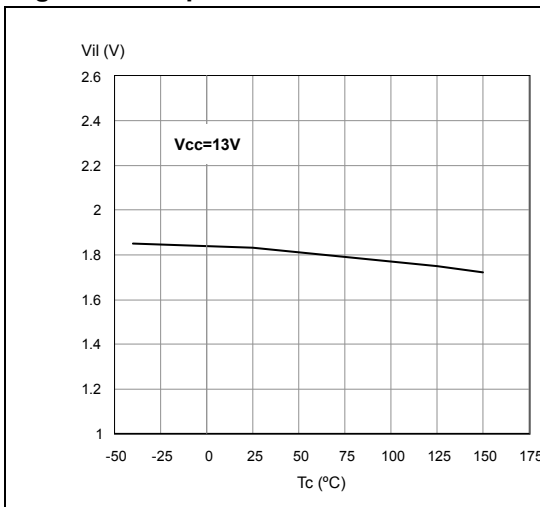

Figure 12. Input hysteresis voltage

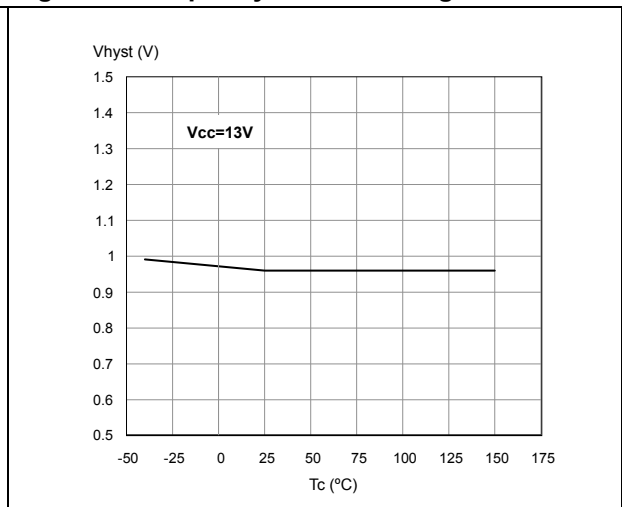

Figure 13. Overvoltage shutdown

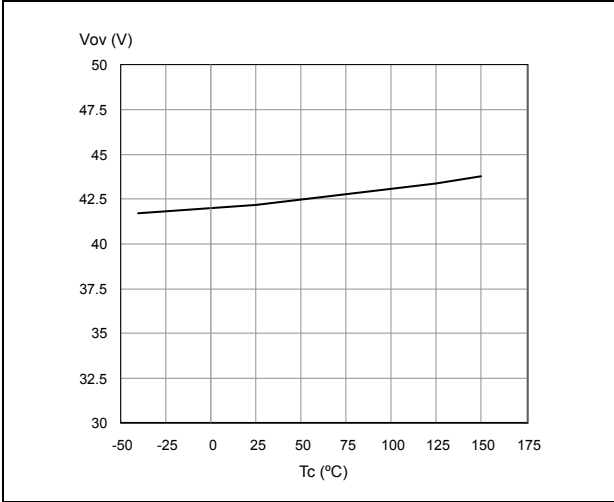

Figure 14. I_{LIM} vs T_{case}

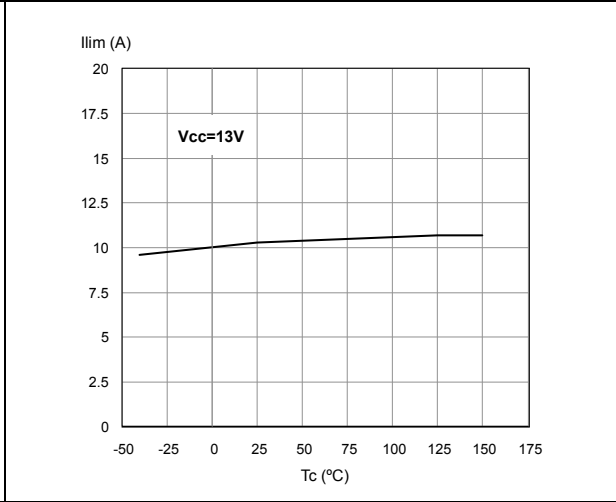

Figure 15. Turn-on voltage slope

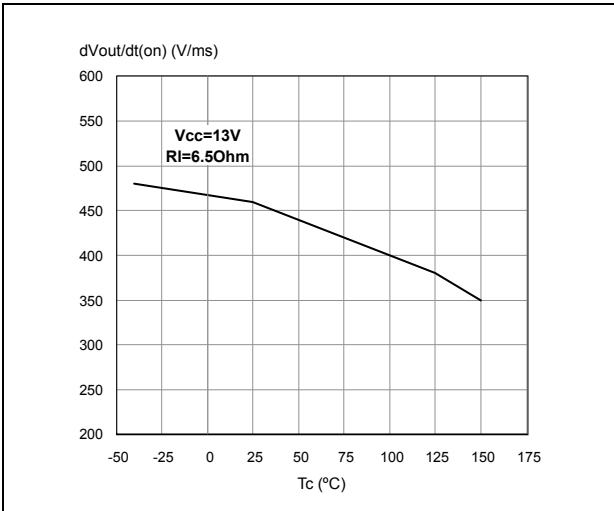

Figure 16. Turn-off voltage slope

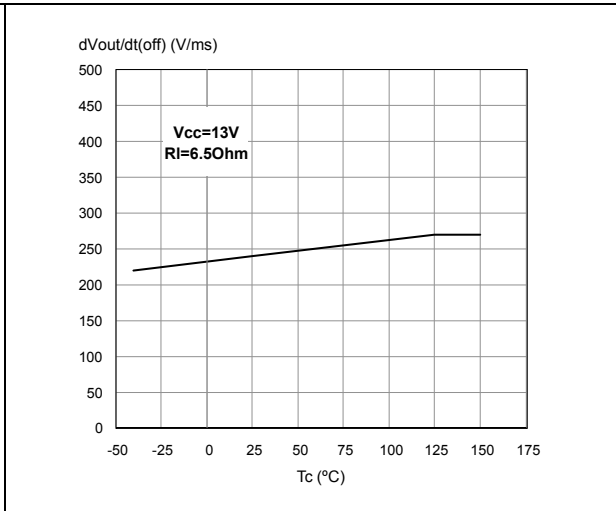

Figure 17. On-state resistance vs T_{case}

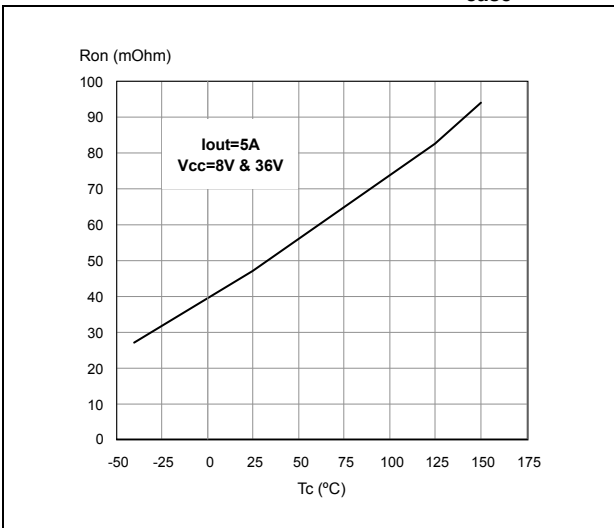
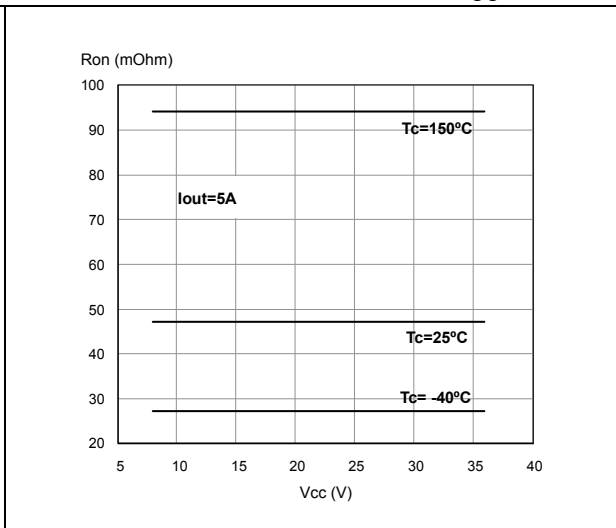
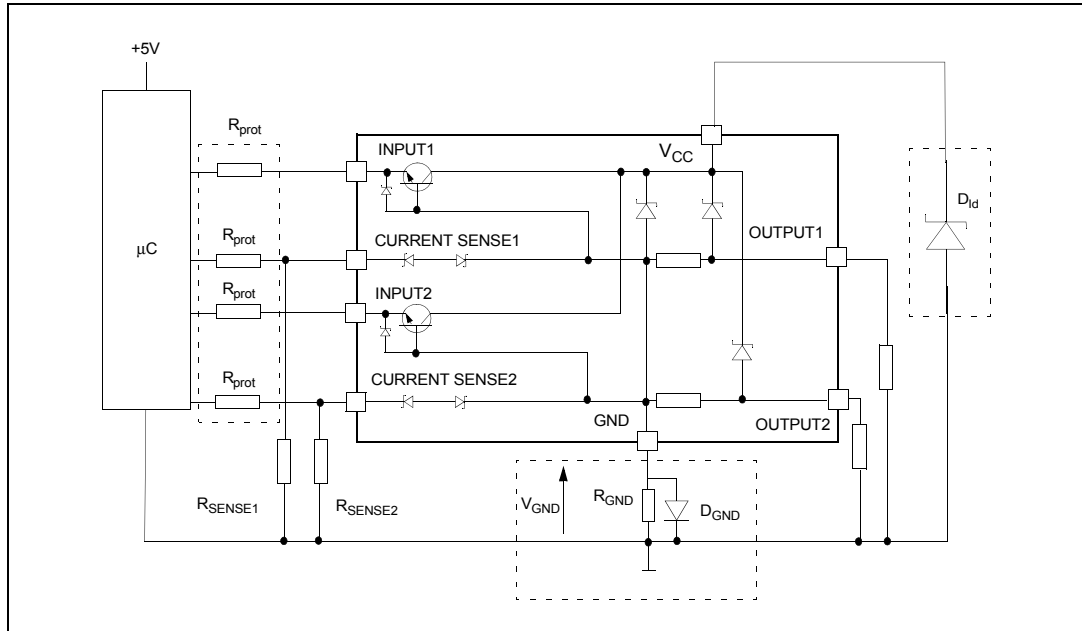

Figure 18. On-state resistance vs V_{CC}



3 Application information

Figure 19. Application schematic



3.1 GND protection network against reverse battery

3.1.1 Solution 1: resistor in the ground line (R_{GND} only)

This can be used with any type of load.

The following is an indication on how to dimension the R_{GND} resistor.

1. $R_{GND} \leq 600 \text{ mV} / I_{S(on)max}$
2. $R_{GND} \geq (-V_{CC}) / (-I_{GND})$

where $-I_{GND}$ is the DC reverse ground pin current and can be found in the absolute maximum rating section of the device's datasheet.

Power dissipation in R_{GND} (when $V_{CC} < 0$: during reverse battery situations) is:

$$P_D = (-V_{CC})^2 / R_{GND}$$

This resistor can be shared amongst several different HSDs. Please note that the value of this resistor should be calculated with formula (1) where $I_{S(on)max}$ becomes the sum of the maximum on-state currents of the different devices.

Please note that if the microprocessor ground is not shared by the device ground then the R_{GND} produces a shift ($I_{S(on)max} * R_{GND}$) in the input thresholds and the status output values. This shift varies depending on how many devices are ON in the case of several high-side drivers sharing the same R_{GND} .

If the calculated power dissipation leads to a large resistor or several devices have to share the same resistor then ST suggests to utilize solution 2 (see [Section 3.1.2](#)).

3.1.2 Solution 2: diode (D_{GND}) in the ground line

A resistor ($R_{GND} = 1 \text{ k}\Omega$) should be inserted in parallel to D_{GND} if the device drives an inductive load.

This small signal diode can be safely shared amongst several different HSDs. Also in this case, the presence of the ground network produces a shift ($\sim 600 \text{ mV}$) in the input threshold and in the status output values if the microprocessor ground is not common to the device ground. This shift does not vary if more than one HSD shares the same diode/resistor network.

Series resistor in INPUT and STATUS lines are also required to prevent that, during battery voltage transient, the current exceeds the absolute maximum rating.

Safest configuration for unused INPUT and STATUS pin is to leave them unconnected, while unused SENSE pin has to be connected to ground pin.

3.2 Load dump protection

D_{ld} is necessary (Voltage Transient Suppressor) if the load dump peak voltage exceeds the V_{CC} max DC rating. The same applies if the device is subject to transients on the V_{CC} line that are greater than the ones shown in [Table 11](#).

3.3 MCU I/Os protection

If a ground protection network is used and negative transient are present on the V_{CC} line, the control pins are pulled negative. ST suggests to insert a resistor (R_{prot}) in line to prevent the microcontroller I/Os pins to latch-up.

The value of these resistors is a compromise between the leakage current of microcontroller and the current required by the HSD I/Os (Input levels compatibility) with the latch-up limit of microcontroller I/Os.

$$-V_{CCpeak}/I_{latchup} \leq R_{prot} \leq (V_{OH\mu C} - V_{IH} - V_{GND}) / I_{IHmax}$$

Calculation example:

For $V_{CCpeak} = -100 \text{ V}$ and $I_{latchup} \geq 20 \text{ mA}$; $V_{OH\mu C} \geq 4.5 \text{ V}$

$$5 \text{ k}\Omega \leq R_{prot} \leq 65 \text{ k}\Omega$$

Recommended values:

$$R_{prot} = 10 \text{ k}\Omega$$

3.4 PowerSO-10 maximum demagnetization energy ($V_{CC} = 13.5\text{ V}$)

Figure 20. Maximum turn-off current versus load inductance⁽¹⁾

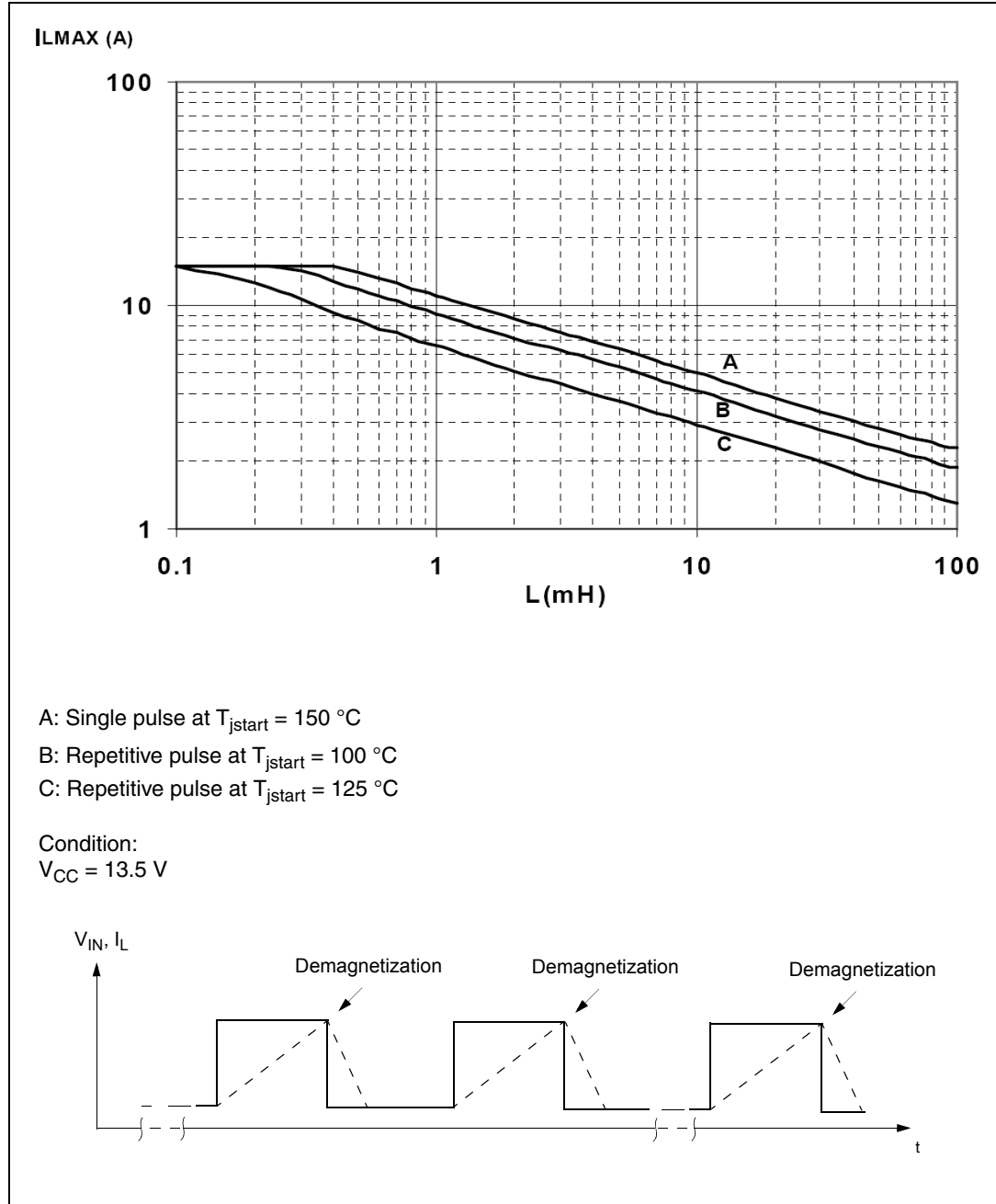

1. Values are generated with $R_L = 0\ \Omega$
 In case of repetitive pulses, T_{jstart} (at beginning of each demagnetization) of every pulse must not exceed the temperature specified above for curves B and C.

4 Package and PCB thermal data

4.1 PowerSO-10 thermal data

Figure 21. PowerSO-10 PC board⁽¹⁾

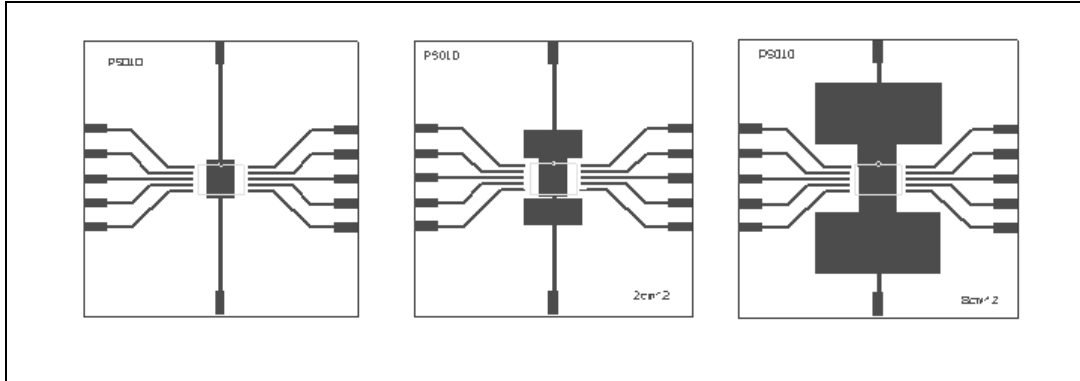

1. Layout condition of R_{th} and Z_{th} measurements (PCB FR4 area= 58 mm x 58 mm, PCB thickness=2 mm, Cu thickness = 35 μ m, Copper areas: from minimum pad lay-out to 8 cm²).

Figure 22. $R_{thj-amb}$ vs PCB copper area in open box free air condition

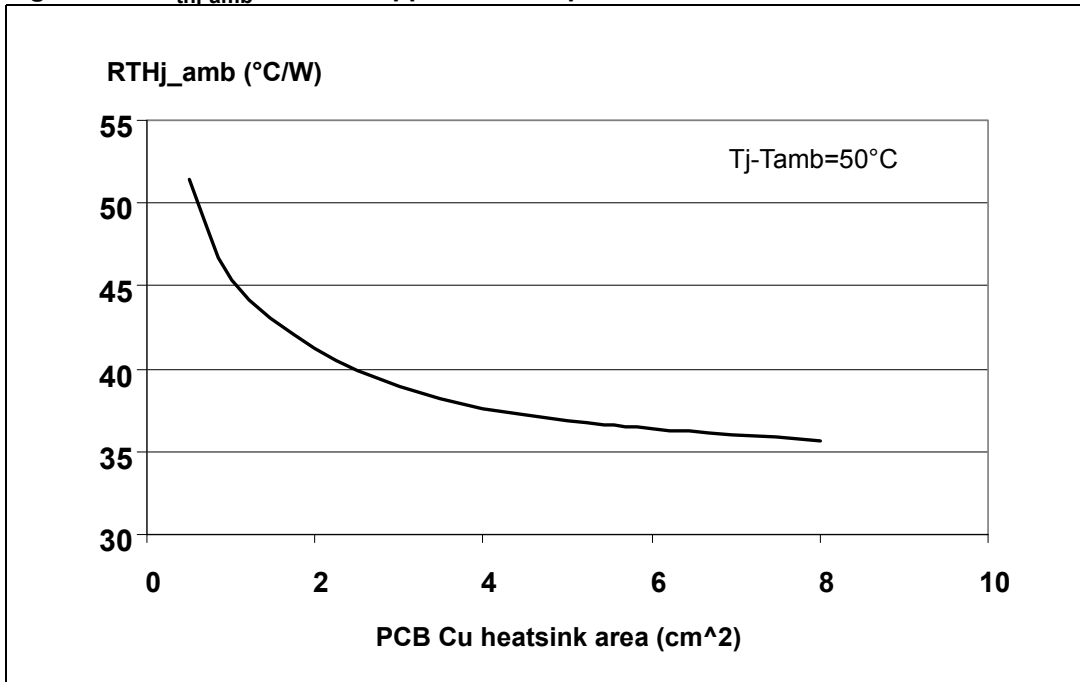
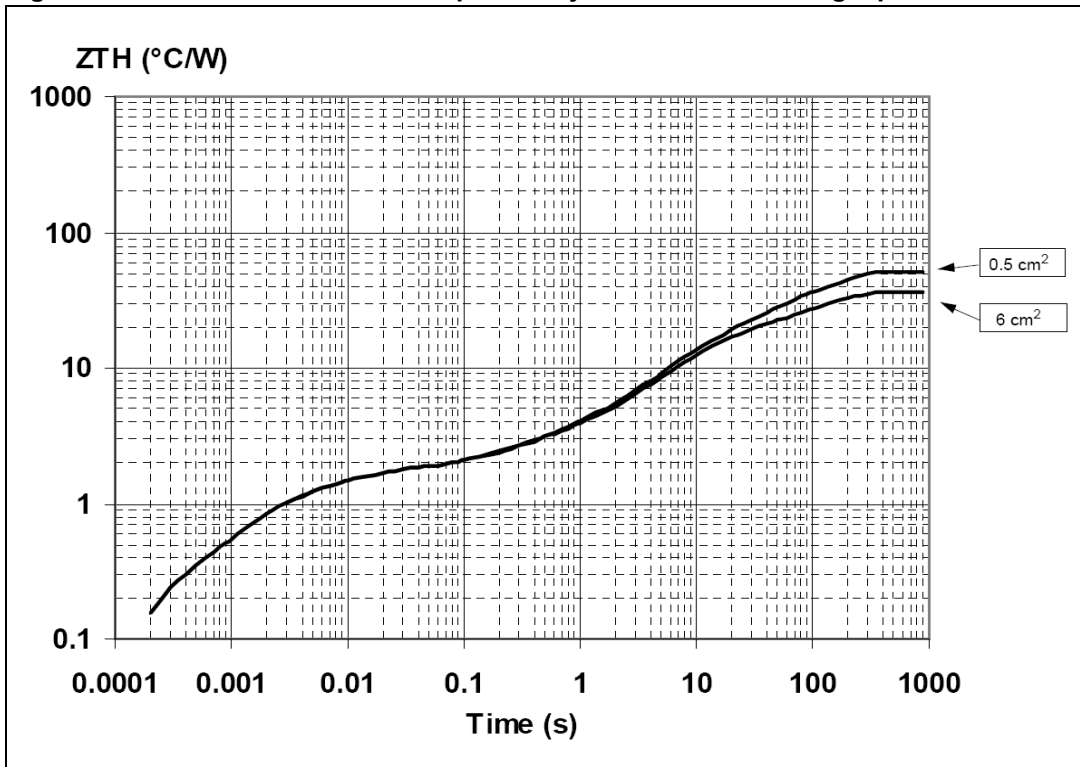

Figure 23. PowerSO-10 thermal impedance junction ambient single pulse



Equation 1: pulse calculation formula

$$Z_{TH\delta} = R_{TH} \cdot \delta + Z_{THtp}(1 - \delta)$$

where $\delta = t_p/T$

Figure 24. Thermal fitting model of a double channel HSD in PowerSO-10

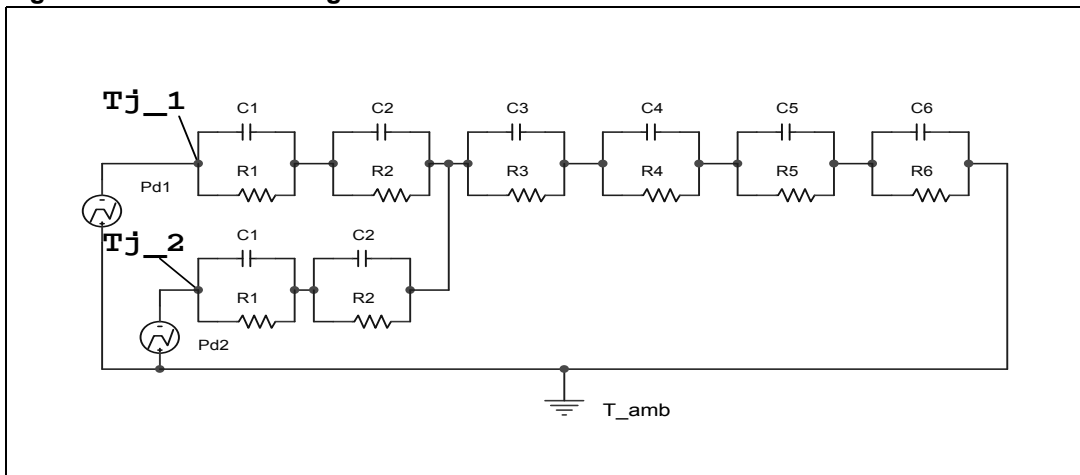

Table 14. Thermal parameter

Area/island (cm ²)	0.5	6
R1 (°C/ W)	0.15	
R2 (°C/ W)	0.8	
R3 (°C/ W)	0.7	
R4 (°C/ W)	0.8	
R5 (°C/ W)	12	
R6 (°C/ W)	37	22
C1 (W.s/ °C)	0.0006	
C2 (W.s /°C)	2.10E-03	
C3 (W.s/ °C)	0.013	
C4 (W.s/ °C)	0.3	
C5 (W.s/ °C)	0.75	
C6 (W.s/ °C)	3	5

5 Package and packing information

5.1 ECOPACK[®] packages

In order to meet environmental requirements, ST offers these devices in different grades of ECOPACK[®] packages, depending on their level of environmental compliance. ECOPACK[®] specifications, grade definitions and product status are available at: www.st.com. ECOPACK[®] is an ST trademark.

5.2 PowerSO-10 mechanical data

Figure 25. PowerSO-10 package dimensions

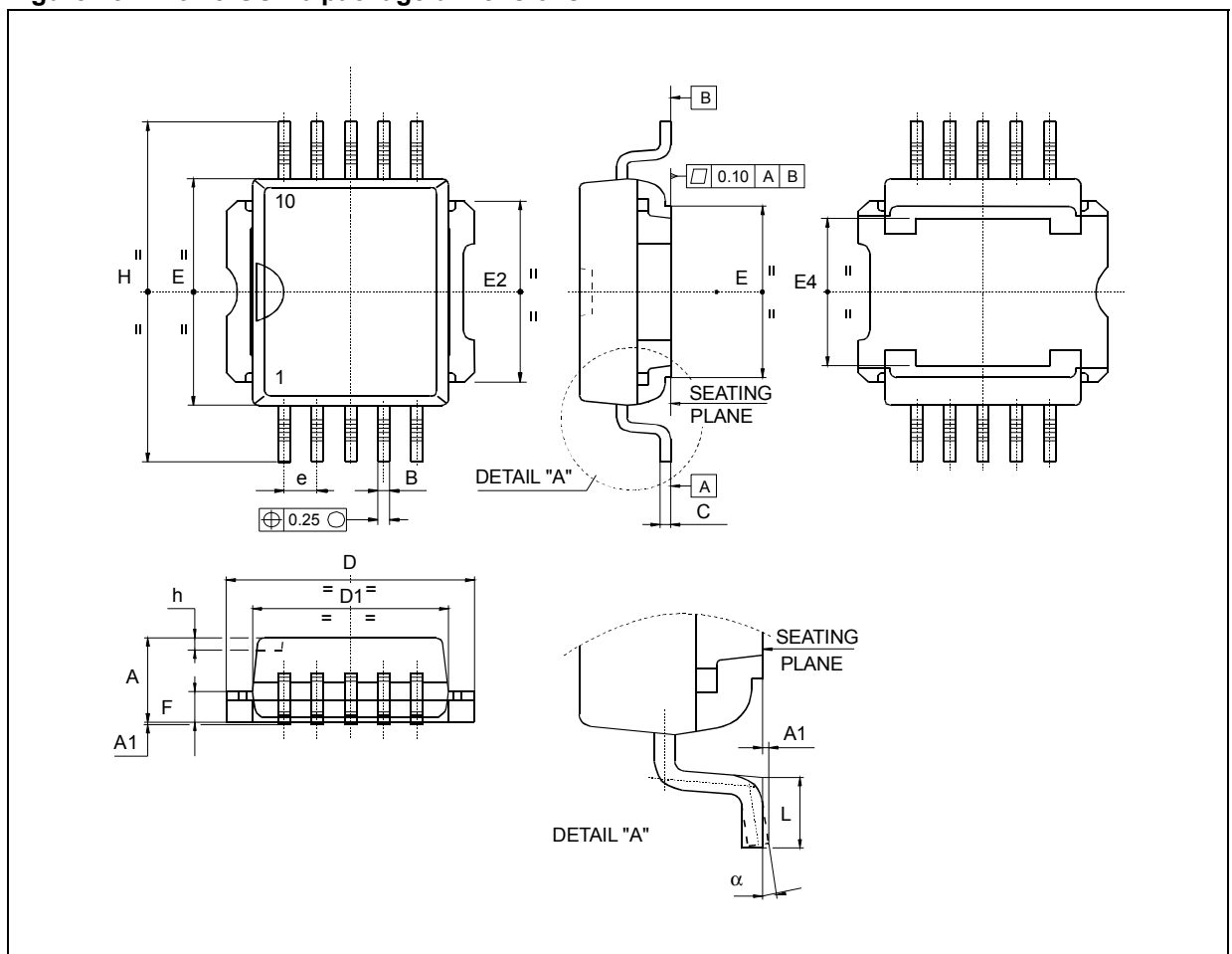

Table 15. PowerSO-10 mechanical data

Dim.	Millimeters		
	Min.	Typ.	Max.
A	3.35		3.65
A ⁽¹⁾	3.4		3.6
A1	0		0.10
B	0.40		0.60
B ⁽¹⁾	0.37		0.53
C	0.35		0.55
C ⁽¹⁾	0.23		0.32
D	9.40		9.60
D1	7.40		7.60
E	9.30		9.50
E2	7.20		7.60
E2 ⁽¹⁾	7.30		7.50
E4	5.90		6.10
E4 ⁽¹⁾	5.90		6.30
e		1.27	
F	1.25		1.35
F ⁽¹⁾	1.20		1.40
H	13.80		14.40
H ⁽¹⁾	13.85		14.35
h		0.50	
L	1.20		1.80
L ⁽¹⁾	0.80		1.10
α	0°		8°
α ⁽¹⁾	2°		8°

1. Muar only POA P013P.

5.3 PowerSO-10 packing information

Figure 26. PowerSO-10 suggested pad layout and tube shipment (no suffix)

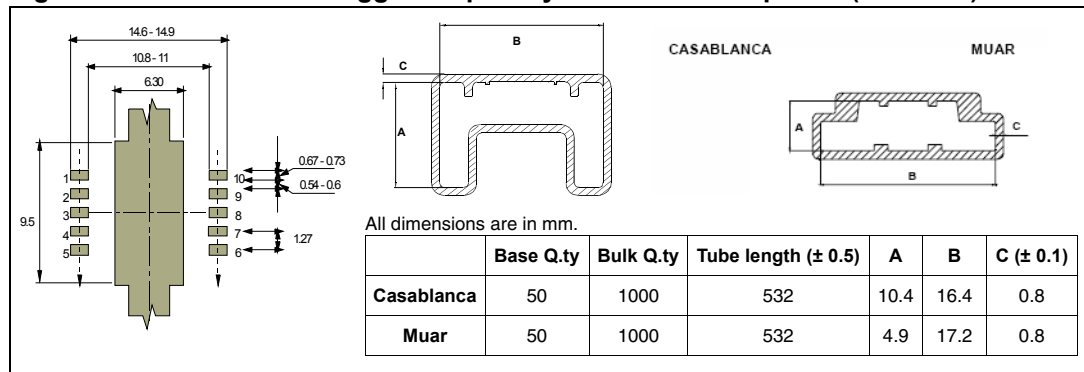
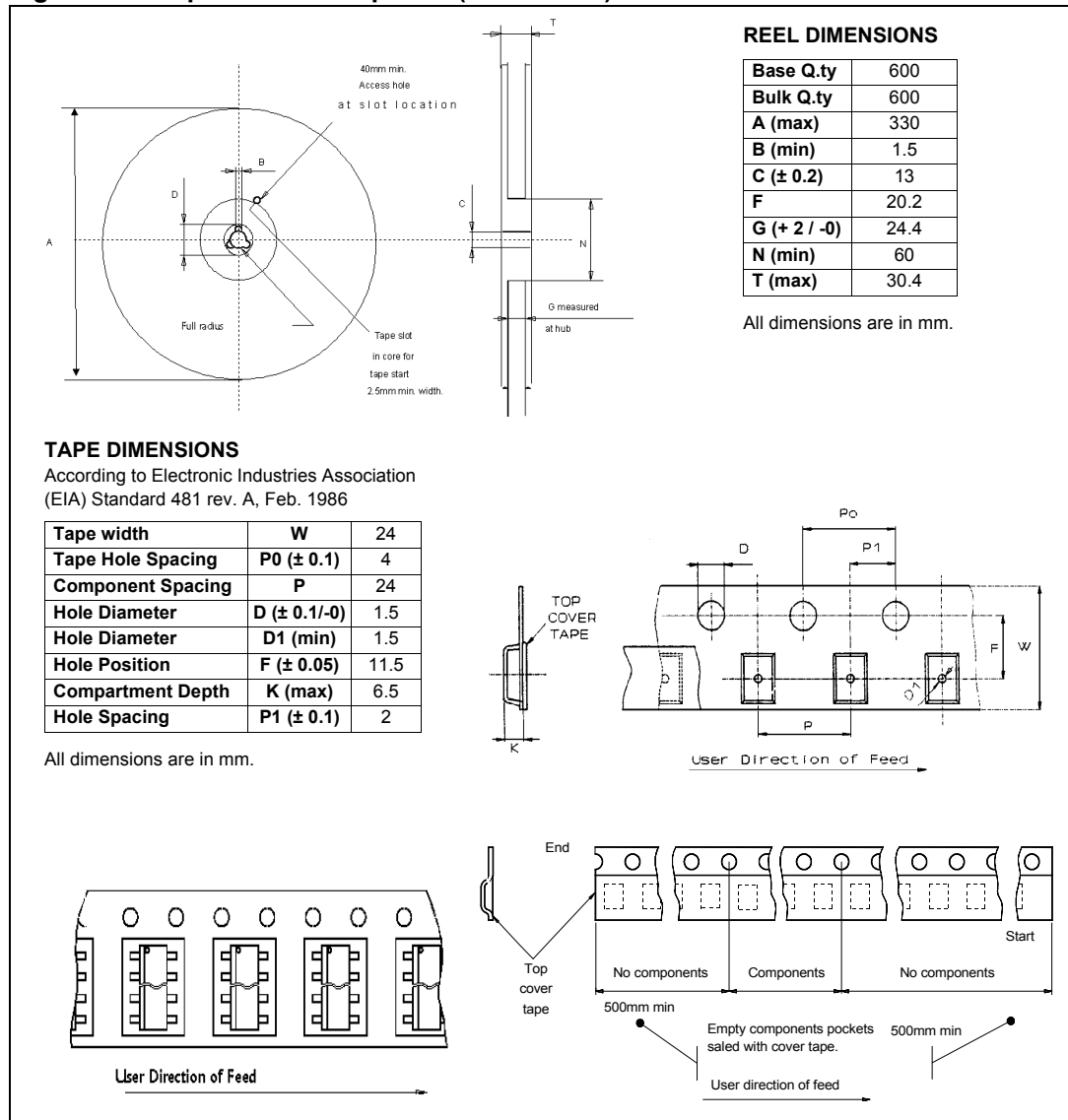

Figure 27. Tape and reel shipment (suffix “TR”)



6 Revision history

Table 16. Document revision history

Date	Revision	Changes
19-Jul-2010	1	Initial release.
19-Sep-2013	2	Updated Disclaimer

Please Read Carefully:

Information in this document is provided solely in connection with ST products. STMicroelectronics NV and its subsidiaries ("ST") reserve the right to make changes, corrections, modifications or improvements, to this document, and the products and services described herein at any time, without notice.

All ST products are sold pursuant to ST's terms and conditions of sale.

Purchasers are solely responsible for the choice, selection and use of the ST products and services described herein, and ST assumes no liability whatsoever relating to the choice, selection or use of the ST products and services described herein.

No license, express or implied, by estoppel or otherwise, to any intellectual property rights is granted under this document. If any part of this document refers to any third party products or services it shall not be deemed a license grant by ST for the use of such third party products or services, or any intellectual property contained therein or considered as a warranty covering the use in any manner whatsoever of such third party products or services or any intellectual property contained therein.

UNLESS OTHERWISE SET FORTH IN ST'S TERMS AND CONDITIONS OF SALE ST DISCLAIMS ANY EXPRESS OR IMPLIED WARRANTY WITH RESPECT TO THE USE AND/OR SALE OF ST PRODUCTS INCLUDING WITHOUT LIMITATION IMPLIED WARRANTIES OF MERCHANTABILITY, FITNESS FOR A PARTICULAR PURPOSE (AND THEIR EQUIVALENTS UNDER THE LAWS OF ANY JURISDICTION), OR INFRINGEMENT OF ANY PATENT, COPYRIGHT OR OTHER INTELLECTUAL PROPERTY RIGHT.

ST PRODUCTS ARE NOT DESIGNED OR AUTHORIZED FOR USE IN: (A) SAFETY CRITICAL APPLICATIONS SUCH AS LIFE SUPPORTING, ACTIVE IMPLANTED DEVICES OR SYSTEMS WITH PRODUCT FUNCTIONAL SAFETY REQUIREMENTS; (B) AERONAUTIC APPLICATIONS; (C) AUTOMOTIVE APPLICATIONS OR ENVIRONMENTS, AND/OR (D) AEROSPACE APPLICATIONS OR ENVIRONMENTS. WHERE ST PRODUCTS ARE NOT DESIGNED FOR SUCH USE, THE PURCHASER SHALL USE PRODUCTS AT PURCHASER'S SOLE RISK, EVEN IF ST HAS BEEN INFORMED IN WRITING OF SUCH USAGE, UNLESS A PRODUCT IS EXPRESSLY DESIGNATED BY ST AS BEING INTENDED FOR "AUTOMOTIVE, AUTOMOTIVE SAFETY OR MEDICAL" INDUSTRY DOMAINS ACCORDING TO ST PRODUCT DESIGN SPECIFICATIONS. PRODUCTS FORMALLY ESCC, QML OR JAN QUALIFIED ARE DEEMED SUITABLE FOR USE IN AEROSPACE BY THE CORRESPONDING GOVERNMENTAL AGENCY.

Resale of ST products with provisions different from the statements and/or technical features set forth in this document shall immediately void any warranty granted by ST for the ST product or service described herein and shall not create or extend in any manner whatsoever, any liability of ST.

ST and the ST logo are trademarks or registered trademarks of ST in various countries.

Information in this document supersedes and replaces all information previously supplied.

The ST logo is a registered trademark of STMicroelectronics. All other names are the property of their respective owners.

© 2013 STMicroelectronics - All rights reserved

STMicroelectronics group of companies

Australia - Belgium - Brazil - Canada - China - Czech Republic - Finland - France - Germany - Hong Kong - India - Israel - Italy - Japan - Malaysia - Malta - Morocco - Philippines - Singapore - Spain - Sweden - Switzerland - United Kingdom - United States of America

www.st.com