

NAP series

NAP -10 -472 -□

① ② ③ ④

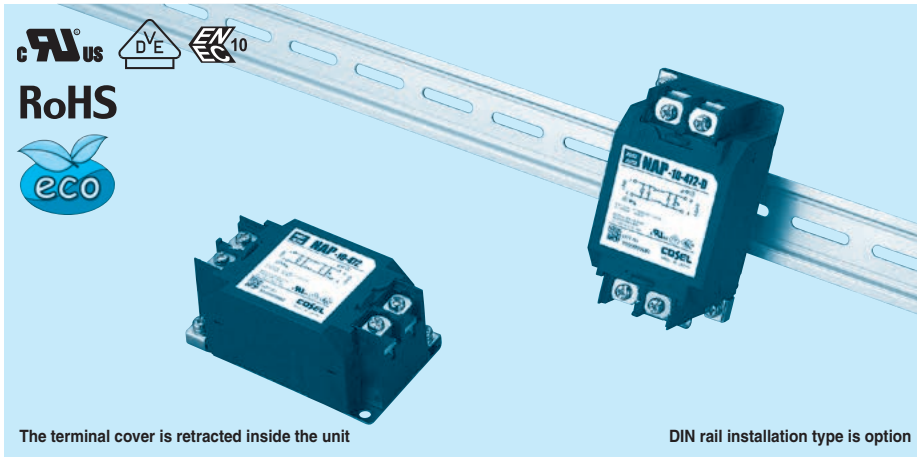

The terminal cover is retracted inside the unit

DIN rail installation type is option

- ① Model Name
- ② Rated Current
- ③ Line to ground capacitor code: See table 1.1.

table 1.1 Line to ground capacitor code

Code	Leakage Current (Input 125/250V 60Hz)	Line to ground capacitor (nominal value)
000	5 μ A/ 10 μ A max	Not Provided
101	12.5 μ A/ 25 μ A max	100pF
221	25 μ A/ 50 μ A max	220pF
331	37.5 μ A/ 75 μ A max	330pF
471	50 μ A/100 μ A max	470pF
681	75.5 μ A/150 μ A max	680pF
102	0.13mA/0.25mA max	1000pF
222	0.25mA/0.5 mA max	2200pF
332	0.38mA/0.75mA max	3300pF
472	0.5 mA/1.0 mA max	4700pF

* When the line to ground capacitor code is different, the attenuation characteristic is different.

- ④ Options
- D: DIN rail installation type

* The dimensions change when the option is set. Refer to External view.

Features of NAP series

High-voltage pulses high-attenuation type

- Single Phase 250 VAC
- Push down type terminal block

Specifications

No.	Items	NAP-04-472	NAP-06-472	NAP-10-472	NAP-16-472	NAP-20-472	NAP-30-472
1	Rated Voltage[V]	AC 1 ϕ 250 / DC250					
2	Rated Current[A]	4	6	10	16	20	30
3	Test Voltage (Terminal-Mounting Plate)	2,500 VAC (Cutoff Current = 20mA), 1minute at room temperature and humidity					
4	Isolation Resistance (Terminal-Mounting Plate)	500 VDC 100M Ω min at room temperature and humidity					
5	Leakage current 125/250V 60Hz	0.5mA/1.0mA max					
6	Voltage drop	1.0V max					
7	Safety agency approval temperatures	-25 to +85 $^{\circ}$ C (Refer to Derating Curve)					
8	Operating temperature	-40 to +85 $^{\circ}$ C (Refer to Derating Curve)					
9	Operating humidity	20 to 95%RH (Non condensing)					
10	Storage temperature/humidity	-40 to +85 $^{\circ}$ C/20 to 95%RH (Non condensing)					
11	Vibration	10 to 55Hz, 19.6m/s 2 (2G), 3min. Period, 1hour each X, Y and Z axis					
12	Impact	196.1m/s 2 (20G), 11ms Once each X, Y and Z axis					
13	Safety agency approvals	UL1283, CSA C22.2 No.8 (C-UL), DIN EN60939 VDE0565 Teil3-1, ENEC (At only AC input)					
14	Case size (without projection) /Weight	53X41 X92 mm [2.09 X 1.61 X 3.62 inches] (W X H X D) /300g max (Option : -D refer to external view)					

Circuit Diagram

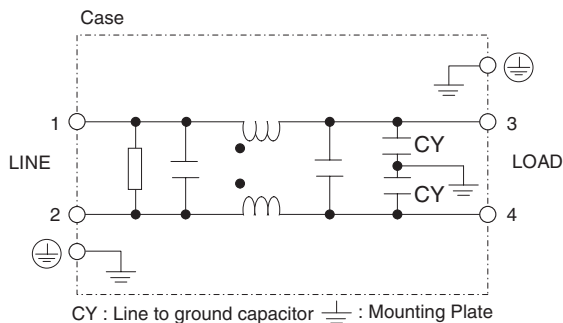

Derating Curve

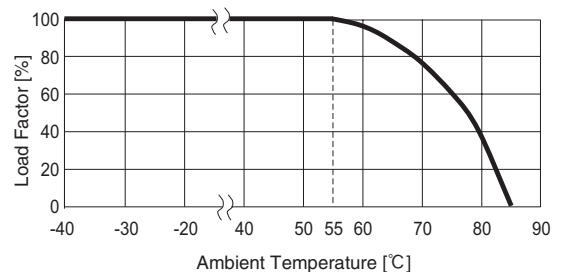

External view

As this product is adopted push-down type terminal block, this appearance is as follows.

- ① The terminal cover is retracted inside the unit.
- ② The screws for connecting the terminals are held in the up right position.

Standard Type

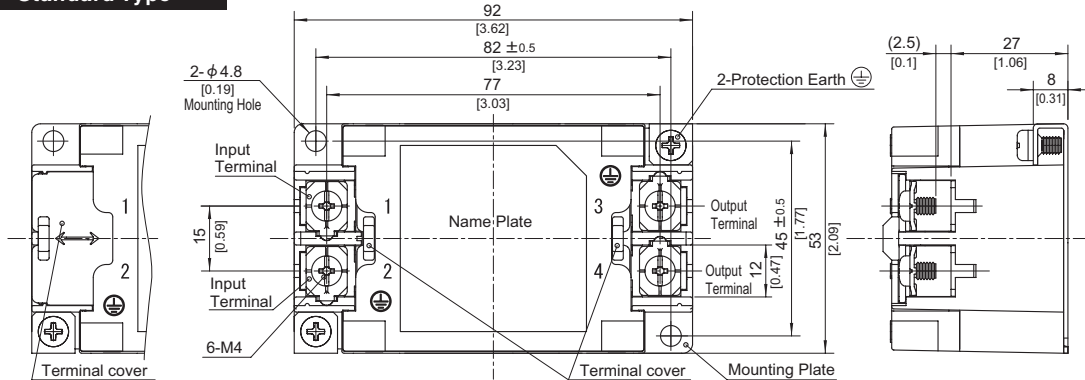

※ Closed the terminal cover

- ※ Tolerance : ± 1 [± 0.04]
- ※ Weight : 300g max
- ※ Mounting Plate : Iron (surface finishing:nickel plating) $t=1.0$ [0.04]
- ※ Case : PBT
- ※ Dimensions in mm, []=inches
- ※ Terminal block screw tightening torque $M4:1.6N \cdot m$ (16.9kgf · cm) max

DIN rail installation Type

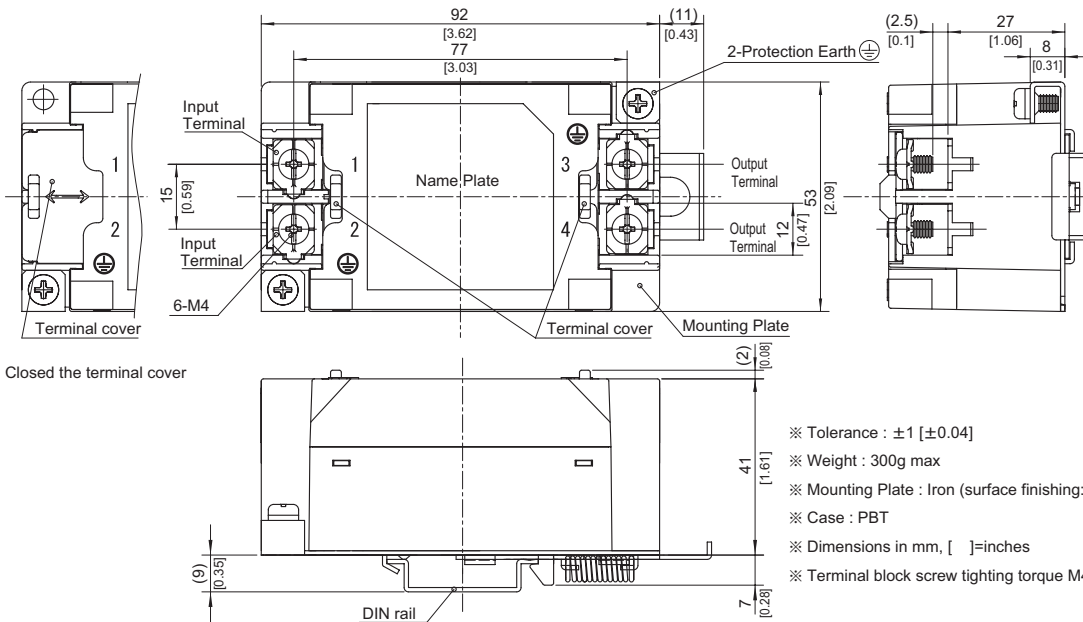

※ Closed the terminal cover

- ※ Tolerance : ± 1 [± 0.04]
- ※ Weight : 300g max
- ※ Mounting Plate : Iron (surface finishing:nickel plating) $t=1.0$ [0.04]
- ※ Case : PBT
- ※ Dimensions in mm, []=inches
- ※ Terminal block screw tightening torque $M4:1.6N \cdot m$ (16.9kgf · cm) max

■Note when installing the EMI/EMC Filter on a DIN rail.

When the EMI/EMC Filter is grounded through the DIN rail, the proper noise attenuation may not be achieved.

Be sure to connect the protection earth (PE) of the EMI/EMC Filter body to the earth. It can connect the ground to either one only.

