

# MITSUBISHI LSTTL<sub>s</sub> M74LS258AP

## QUADRUPLE 2-LINE TO 1-LINE DATA SELECTOR/MULTIPLEXER WITH 3-STATE OUTPUT (INVERTED)

### DESCRIPTION

The M74LS258AP is a semiconductor integrated circuit containing four 2-line to 1-line data selector/multiplexer circuits with 3-stage outputs.

### FEATURES

- Inverted outputs
- Output control input common to all four circuits
- Select input common to all four circuits
- 3-state outputs
- Wide operating temperature range ( $T_a = -20 \sim +75^\circ\text{C}$ )

### APPLICATION

General purpose, for use in industrial and consumer equipment.

### FUNCTIONAL DESCRIPTION

This IC contains four sets of circuits which are used 1-line selection 2 input signals and as both data selectors, selecting 1-line out of 2 input signals, and multiplexers which convert the 2-bit parallel data into serial data by time-sharing. When one out of 2-line signals, which are applied to the data inputs  $D_0$  and  $D_1$ , is specified by select from input  $S_A$ , inverted signal of that appears at output  $\bar{Y}$ .

$S_A$  and output control  $\overline{OC}$  are common to all four circuits. When  $\overline{OC}$  is set high,  $1\bar{Y}$ ,  $2\bar{Y}$ ,  $3\bar{Y}$  and  $4\bar{Y}$  are put in the high-impedance state irrespective of the status of the other inputs.

M74LS258AP has the same functions and pin connections as M74LS158P but the latter is provided with active pull-up resistor outputs.

### PIN CONFIGURATION (TOP VIEW)

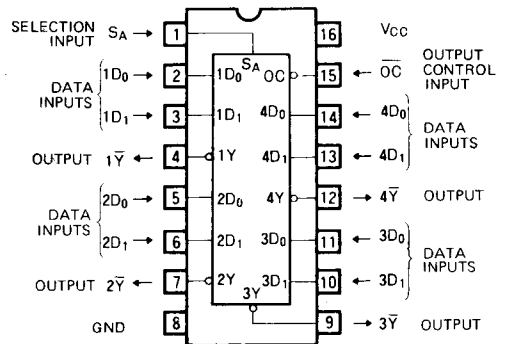

### FUNCTION TABLE (Note 1)

$\overline{OC}$	$S_A$	$D_0$	$D_1$	$\bar{Y}$
H	X	X	X	Z
L	L	L	X	H
L	L	H	X	L
L	H	X	L	H
L	H	X	H	L

Note 1 X : Irrelevant

Z : High-impedance state

### BLOCK DIAGRAM

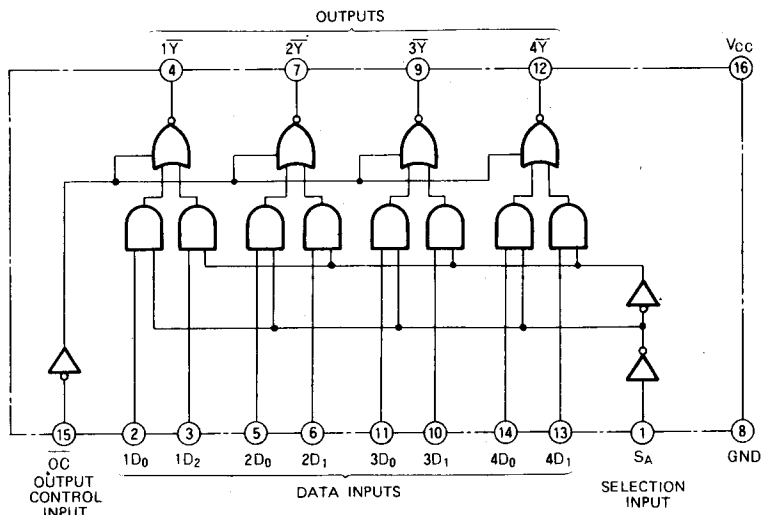

**QUADRUPL 2-LINE TO 1-LINE DATA SELECTOR/MULTIPLEXER  
WITH 3-STATE OUTPUT (INVERTED)**

**ABSOLUTE MAXIMUM RATINGS** (  $T_a = -20 \sim +75^\circ\text{C}$ , unless otherwise noted )

Symbol	Parameter	Conditions	Limits	Unit
$V_{CC}$	Supply voltage		- 0.5 ~ + 7	V
$V_I$	Input voltage		- 0.5 ~ + 15	V
$V_O$	Output voltage	Off-state	- 0.5 ~ + 5.5	V
$T_{opr}$	Operating free-air ambient temperature range		- 20 ~ + 75	$^\circ\text{C}$
$T_{stg}$	Storage temperature range		- 65 ~ + 150	$^\circ\text{C}$

**RECOMMENDED OPERATING CONDITIONS** (  $T_a = -20 \sim +75^\circ\text{C}$ , unless otherwise noted )

Symbol	Parameter	Limits			Unit
		Min	Typ	Max	
$V_{CC}$	Supply voltage	4.75	5	5.25	V
$I_{OH}$	High-level output current	$V_{OH} \geq 2.4\text{V}$	0	- 2.6	mA
$I_{OL}$	Low-level output current	$V_{OL} \leq 0.4\text{V}$	0	12	mA
		$V_{OL} \leq 0.5\text{V}$	0	24	mA

**ELECTRICAL CHARACTERISTICS** (  $T_a = -20 \sim +75^\circ\text{C}$ , unless otherwise noted )

Symbol	Parameter	Test conditions	Limits			Unit
			Min	Typ *	Max	
$V_{IH}$	High-level input voltage		2			V
$V_{IL}$	Low-level input voltage				0.8	V
$V_{IC}$	Input clamp voltage	$V_{CC} = 4.75\text{V}$ , $I_{IC} = -18\text{mA}$			- 1.5	V
$V_{OH}$	High-level output voltage	$V_{CC} = 4.75\text{V}$ , $V_I = 0.8\text{V}$ $V_I = 2\text{V}$ , $I_{OH} = -2.6\text{mA}$	2.4	3.1		V
$V_{OL}$	Low-level output voltage	$V_{CC} = 4.75\text{V}$		0.25	0.4	V
		$V_I = 0.8\text{V}$ , $V_I = 2\text{V}$		0.35	0.5	V
$I_{OZH}$	Off-state high-level output current	$V_{CC} = 5.25\text{V}$ , $V_I = 2\text{V}$ , $V_O = 2.7\text{V}$			20	$\mu\text{A}$
$I_{OZL}$	Off-state low-level output current	$V_{CC} = 5.25\text{V}$ , $V_I = 2\text{V}$ , $V_O = 0.4\text{V}$			- 20	$\mu\text{A}$
$I_{IH}$	High-level input current	$D_0, D_1, \overline{OC}$	$V_{CC} = 5.25\text{V}$		20	$\mu\text{A}$
		$S_A$	$V_I = 2.7\text{V}$		40	$\mu\text{A}$
		$D_0, D_1, \overline{OC}$	$V_{CC} = 5.25\text{V}$		0.1	mA
		$S_A$	$V_I = 10\text{V}$		0.2	mA
$I_{IL}$	Low-level input current	$D_0, D_1, \overline{OC}$	$V_{CC} = 5.25\text{V}$		- 0.4	mA
		$S_A$	$V_I = 0.4\text{V}$		- 0.8	mA
$I_{OS}$	Short-circuit output current (Note 2)	$V_{CC} = 5.25\text{V}$ , $V_O = 0\text{V}$	- 30		130	mA
$I_{CCH}$	Supply current, all outputs high	$V_{CC} = 5.25\text{V}$ (Note 3)		4.5	7	mA
$I_{CCL}$	Supply current, all outputs low	$V_{CC} = 5.25\text{V}$ (Note 4)		8.8	14	mA
$I_{CCZ}$	Supply current, all outputs off	$V_{CC} = 5.25\text{V}$ (Note 5)		12	19	mA

\* : All typical values are at  $V_{CC} = 5\text{V}$ ,  $T_a = 25^\circ\text{C}$ .

Note 2: All measurements should be done quickly and not more than one output should be shorted at a time.

Note 3:  $I_{CCH}$  is measured with all inputs at 0V.

Note 4:  $I_{CCL}$  is measured with  $\overline{OC}$ ,  $S_A$  and  $D_1$  at 0V and  $D_0$  at 4.5V.

Note 5:  $I_{CCZ}$  is measured with  $\overline{OC}$  at 4.5V and all other inputs at 0V.

**SWITCHING CHARACTERISTICS** (  $V_{CC} = 5\text{V}$ ,  $T_a = 25^\circ\text{C}$ , unless otherwise noted )

Symbol	Parameter	Test conditions	Limits			Unit	
			Min	Typ	Max		
$t_{PLH}$	Low-to-high-level, high-to-low-level output propagation time, from inputs $D_0, D_1$ to output $\overline{Y}$	$C_L = 45\text{pF}$ (Note 6)		5	18	ns	
$t_{PHL}$				8	18	ns	
$t_{PLH}$	Low-to-high-level, high-to-low-level output propagation time, from input $S_A$ to output $\overline{Y}$			9	28	ns	
$t_{PHL}$				16	35	ns	
$t_{PZH}$	Output enable time to high-level		$R_L = 667\Omega$ , $C_L = 45\text{pF}$ (Note 6)		7	22	ns
$t_{PZL}$	Output enable time to low-level		$R_L = 667\Omega$ , $C_L = 45\text{pF}$ (Note 6)		12	35	ns
$t_{PLZ}$	Output disable time from low-level	$R_L = 667\Omega$ , $C_L = 5\text{pF}$ (Note 6)		11	26	ns	
$t_{PHZ}$	Output disable time from high-level	$R_L = 667\Omega$ , $C_L = 5\text{pF}$ (Note 6)		8	35	ns	

**QUADRUPLE 2-LINE TO 1-LINE DATA SELECTOR/MULTIPLEXER WITH 3-STATE OUTPUT (INVERTED)**

Note 6: Measurement circuit

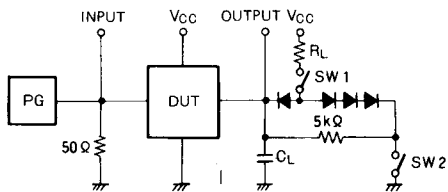

Symbol	SW 1	SW 2
$t_{PZH}$	Open	Closed
$t_{PZL}$	Closed	Open
$t_{PLZ}$	Closed	Closed
$t_{PHZ}$	Closed	Closed

- (1) The pulse generator (PG) has the following characteristics:  
 PRR=1MHz,  $t_r=6ns$ ,  $t_f=6ns$ ,  $t_w=500ns$ ,  $V_p=3V_{p.p.}$ ,  $Z_0=50\Omega$ .
- (2) All diodes are switching diodes.
- (3)  $C_L$  includes probe and jig capacitance

TIMING DIAGRAM (Reference level = 1.3V)

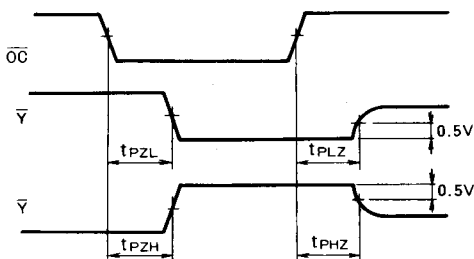
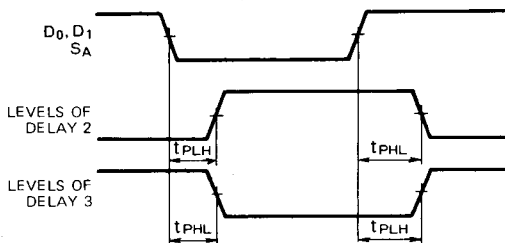

T-90-20

**TYPE 14P4 14-PIN MOLDED PLASTIC DIL**

Dimension in mm

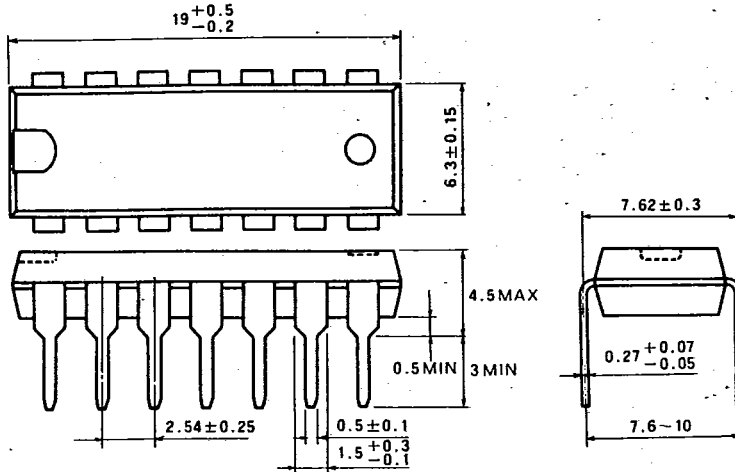

**TYPE 16P4 16-PIN MOLDED PLASTIC DIL**

Dimension in mm

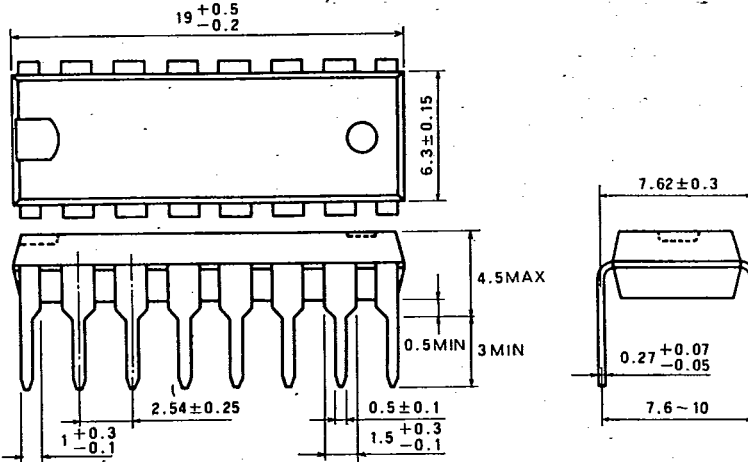

**TYPE 20P4 20-PIN MOLDED PLASTIC DIL**

Dimension in mm

