

PRELIMINARY SPEC

Part Number: BLF051ZGC-28V-P

Green



ATTENTION
OBSERVE PRECAUTIONS
FOR HANDLING
ELECTROSTATIC
DISCHARGE
SENSITIVE
DEVICES

Features

- Built-in current limiting resistor for direct application of different across current.
- Long life.
- Low current, power savings.
- Low maintenance.
- Different color available.
- Solid state, high vibration resistant.
- 28V internal resistor.
- RoHS compliant.

Description

The Green source color devices are made with InGaN on Sapphire Light Emitting Diode.

Static electricity and surge damage the LEDs.

It is recommended to use a wrist band or

Package Dimensions

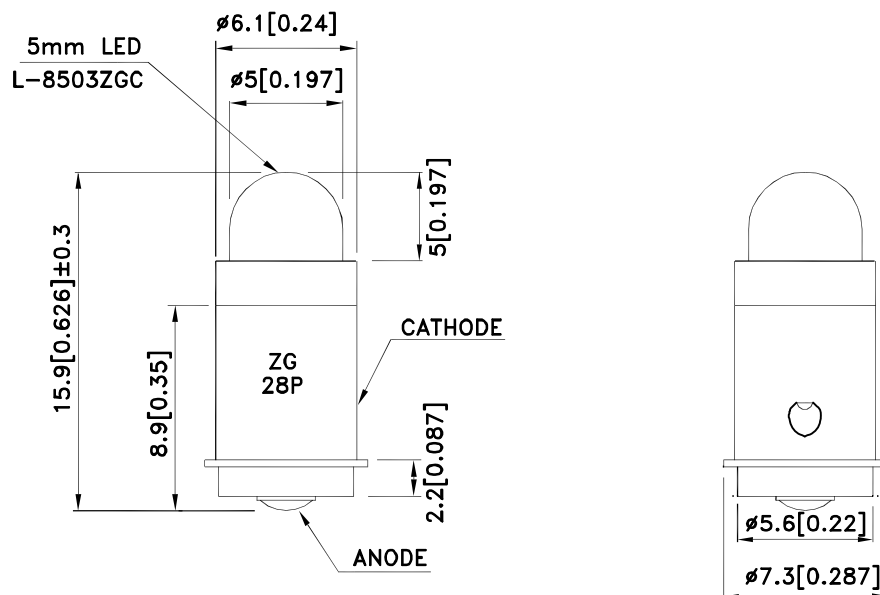

Notes:

1. All dimensions are in millimeters (inches).
2. Tolerance is ±0.25(0.01") unless otherwise noted.
3. Specifications are subject to change without notice.



Selection Guide

| Part No. | Dice | Lens Type | Iv (mcd) V= 28V | | Viewing Angle |
|-----------------|---------------|-------------|--------------------|------|---------------|
| | | | Min. | Typ. | 2θ1/2 |
| BLF051ZGC-28V-P | Green (InGaN) | WATER CLEAR | 1500 | 3000 | 30° |

Note:

1. θ1/2 is the angle from optical centerline where the luminous intensity is 1/2 the optical centerline value.

Electrical / Optical Characteristics at TA=25°C

| Symbol | Parameter | Device | Typ. | Max. | Units | Test Conditions |
|-----------------------|--------------------------|--------|------|------|-------|---------------------|
| λ_{peak} | Peak Wavelength | Green | 515 | | nm | V _F =28V |
| λ_D | Dominant Wavelength | Green | 525 | | nm | V _F =28V |
| $\Delta\lambda_{1/2}$ | Spectral Line Half-width | Green | 30 | | nm | V _F =28V |
| I _F | Forward Current | Green | 10.5 | 13 | mA | V _F =28V |
| I _R | Reverse Current | Green | | 10 | uA | V _R = 5V |

Absolute Maximum Ratings at TA=25°C

| Parameter | Green | Units |
|-----------------------|----------------|-------|
| Power dissipation | 390 | mW |
| Forward Voltage | 30 | V |
| Reverse Voltage | 5 | V |
| Operating Temperature | -40°C To +70°C | |
| Storage Temperature | -40°C To +85°C | |

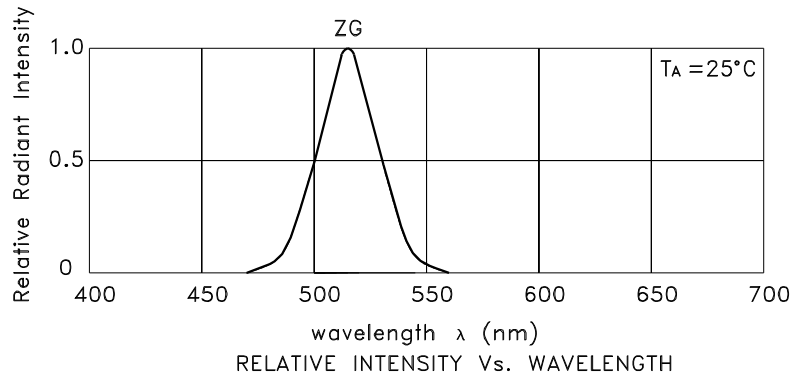

Green

BLF051ZGC-28V-P

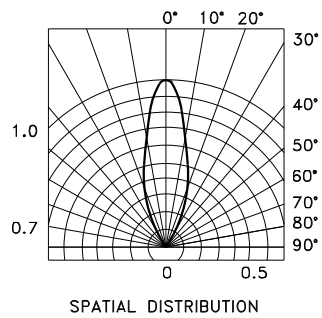
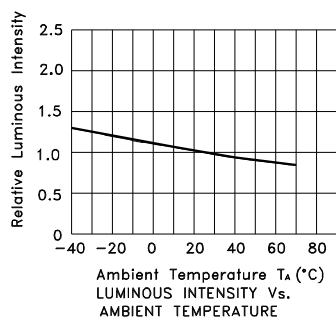
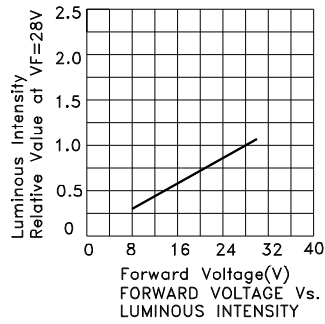
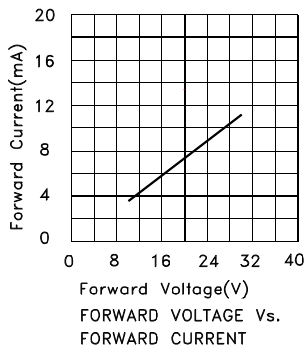

Kingbright

PACKING & LABEL SPECIFICATIONS

BLF051ZGC-28V-P

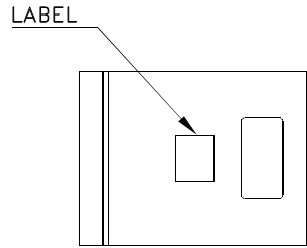
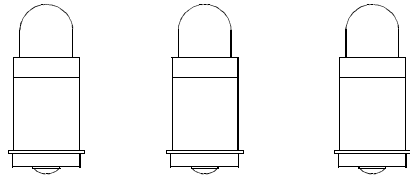

200 PCS / BAG



10K / 9# BOX

OUTSIDE LABEL



OUTSIDE LABEL

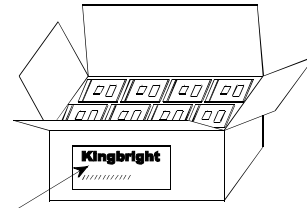

5K / 5# BOX

| | |
|---|--|
| <h1>Kingbright</h1> | |
| P/NO:BLF051xxx | |
| QTY: 200 pcs | Q.C. Q C XX XX XXXX PASSED |
| S/N: XXXX | |
| CODE: XXX | |
| LOT NO: | |
|  <small>xxxxxxxxxxxxxxxxxxxxxxxxxxxxxxxx</small> | |
| RoHS Compliant | |

Mouser Electronics

Authorized Distributor

Click to View Pricing, Inventory, Delivery & Lifecycle Information:

[Kingbright:](#)

[BLF051ZGC-28V-P](#)