

N-Channel Enhancement-Mode MOSFET

V_{DS} 30V R_{DS(ON)} 7mΩ I_D 78A



TRENCH GENFET®

New Product

TO-252 (DPAK)

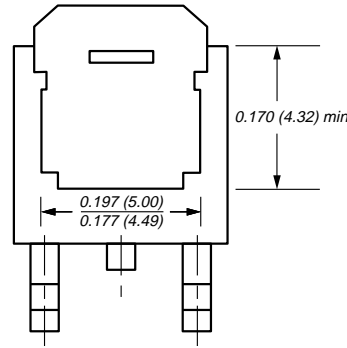
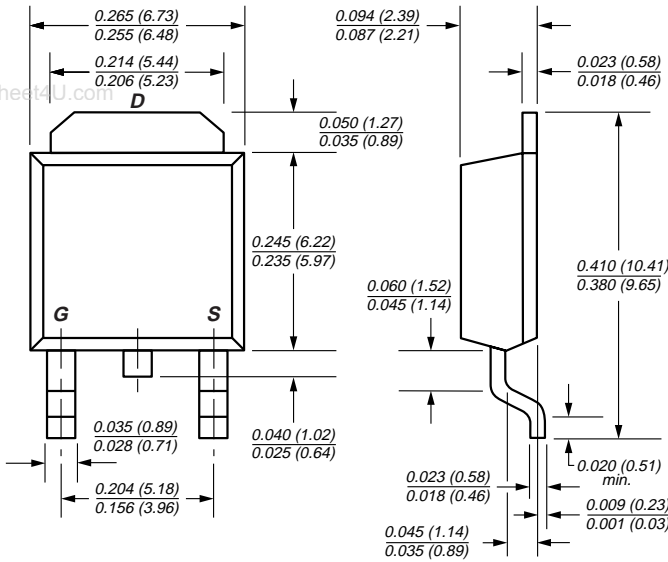
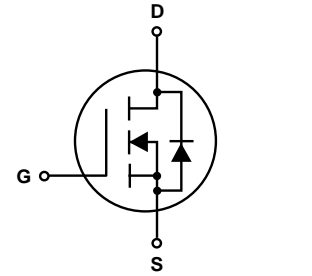

Dimensions in inches and (millimeters)

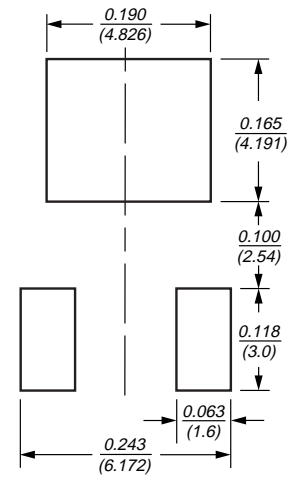

Mounting Pad Layout

Mechanical Data

Case: JEDEC TO-252 molded plastic body
Terminals: Solder plated, solderable per MIL-STD-750, Method 2026
High temperature soldering guaranteed: 250°C/10 seconds at terminals
Weight: 0.011oz., 0.4g

Features

- Advanced Trench Process Technology
- High Density Cell Design for Ultra Low On-Resistance
- Specially Designed for Low Voltage DC/DC Converters
- Fast Switching for High Efficiency

Maximum Ratings and Thermal Characteristics (T_C = 25°C unless otherwise noted)

Parameter	Symbol	Limit	Unit	
Drain-Source Voltage	V _{DS}	30	V	
Gate-Source Voltage	V _{GS}	±20		
Continuous Drain Current ⁽¹⁾	I _D	78	A	
Pulsed Drain Current	I _{DM}	180		
Maximum Power Dissipation	P _D	T _C = 25°C	70	W
		T _C = 70°C	45	
Operating Junction and Storage Temperature Range	T _J , T _{stg}	-55 to 150	°C	
Junction-to-Case Thermal Resistance	R _{θJC}	1.8	°C/W	
Junction-to-Ambient Thermal Resistance ⁽²⁾	R _{θJA}	40	°C/W	

Notes: (1) Maximum DC current limited by the package
 (2) 1-in² 2oz. Cu PCB mounted

N-Channel Enhancement-Mode MOSFET

Electrical Characteristics ($T_J = 25^\circ\text{C}$ unless otherwise noted)

Parameter	Symbol	Test Condition	Min	Typ	Max	Unit
Static						
Drain-Source Breakdown Voltage	BV_{DSS}	$V_{GS} = 0V, I_D = 250\mu A$	30	—	—	V
Gate Threshold Voltage	$V_{GS(th)}$	$V_{DS} = V_{GS}, I_D = 250\mu A$	1.0	—	3.0	V
Gate-Body Leakage	I_{GSS}	$V_{DS} = 0V, V_{GS} = \pm 20V$	—	—	± 100	nA
Zero Gate Voltage Drain Current	I_{DSS}	$V_{DS} = 30V, V_{GS} = 0V$	—	—	1.0	μA
On-State Drain Current ⁽¹⁾	$I_{D(on)}$	$V_{DS} \geq 5V, V_{GS} = 10V$	50	—	—	A
Drain-Source On-State Resistance ⁽¹⁾	$R_{DS(on)}$	$V_{GS} = 10V, I_D = 15A$	—	6.2	7	m Ω
		$V_{GS} = 4.5V, I_D = 13A$	—	8.5	10	
Forward Transconductance ⁽¹⁾	g_{fs}	$V_{DS} = 15V, I_D = 15A$	—	50	—	S
Dynamic						
Total Gate Charge	Q_g	$V_{DS}=15V, V_{GS}=5V, I_D=15A$	—	31	43	nC
Gate-Source Charge	Q_{gs}	$V_{DS} = 15V, V_{GS} = 10V$ $I_D = 15A$	—	60	84	
Gate-Drain Charge	Q_{gd}		—	9	—	
Turn-On Delay Time	$t_{d(on)}$	$V_{DD} = 15V, R_L = 15\Omega$ $I_D \cong 1A, V_{GEN} = 10V$ $R_G = 6\Omega$	—	13	26	ns
Turn-On Rise Time	t_r		—	16	29	
Turn-Off Delay Time	$t_{d(off)}$		—	94	132	
Turn-Off Fall Time	t_f		—	38	57	
Input Capacitance	C_{iss}	$V_{GS} = 0V$	—	3240	—	pF
Output Capacitance	C_{oss}	$V_{DS} = 15V$	—	625	—	
Reverse Transfer Capacitance	C_{rss}	$f = 1.0MHz$	—	285	—	
Source-Drain Diode						
Max Diode Forward Current	I_S	—	—	—	20	A
Diode Forward Voltage ⁽¹⁾	V_{SD}	$I_S = 20A, V_{GS} = 0V$	—	0.85	1.3	V

Notes: (1) Pulse test; pulse width $\leq 300 \mu s$, duty cycle $\leq 2\%$

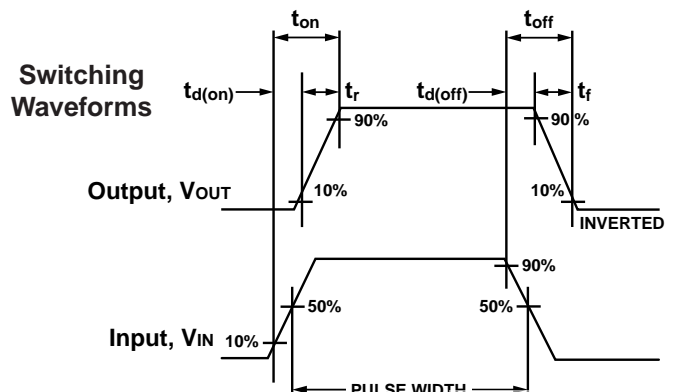
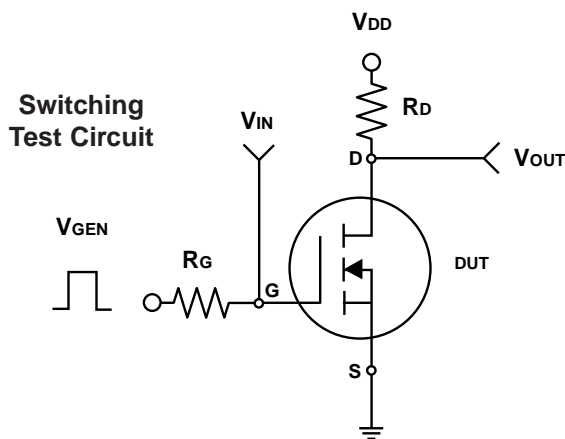

N-Channel Enhancement-Mode MOSFET

Ratings and Characteristic Curves ($T_A = 25^\circ\text{C}$ unless otherwise noted)

Fig. 1 – Output Characteristics

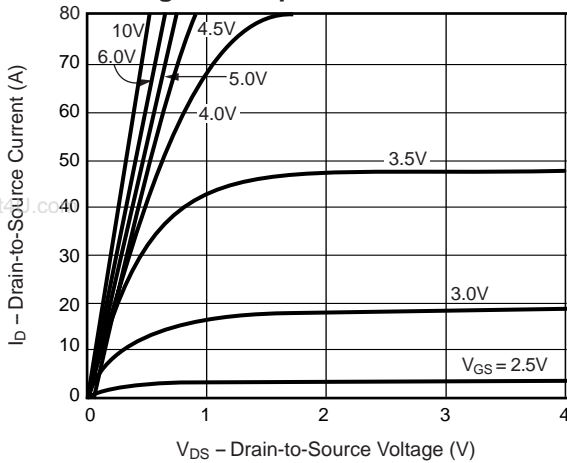

Fig. 2 – Transfer Characteristics

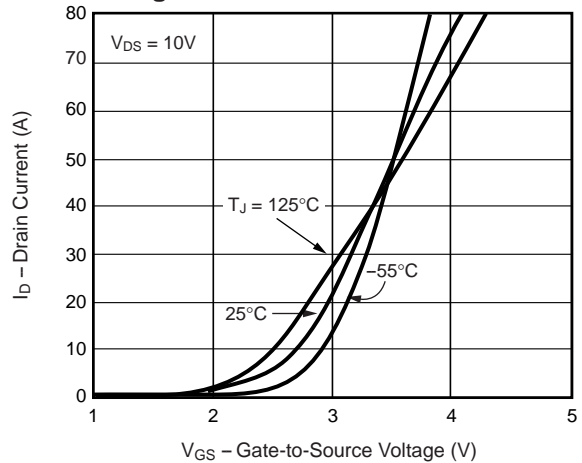

Fig. 3 – Threshold Voltage

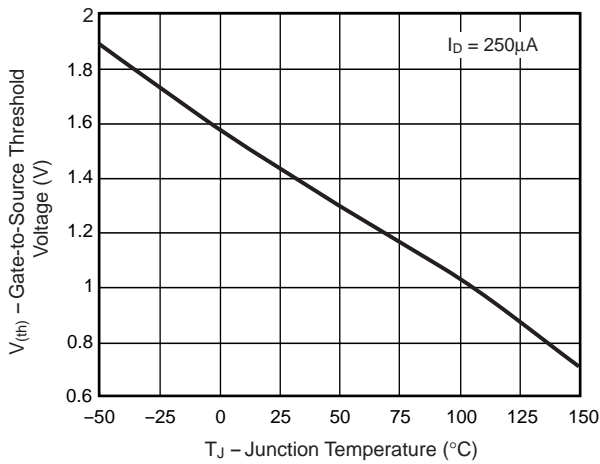

Fig. 4 – On-Resistance vs. Drain Current

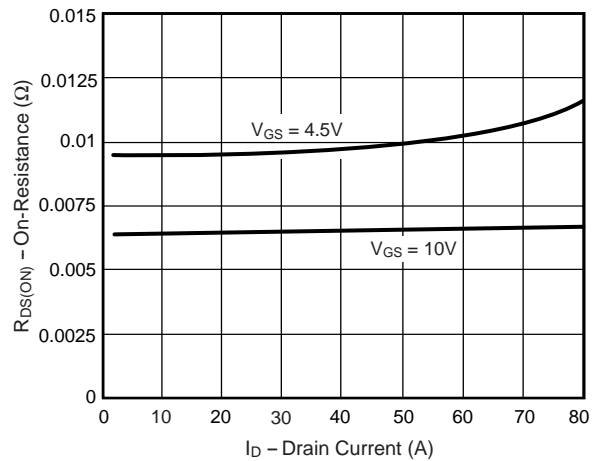
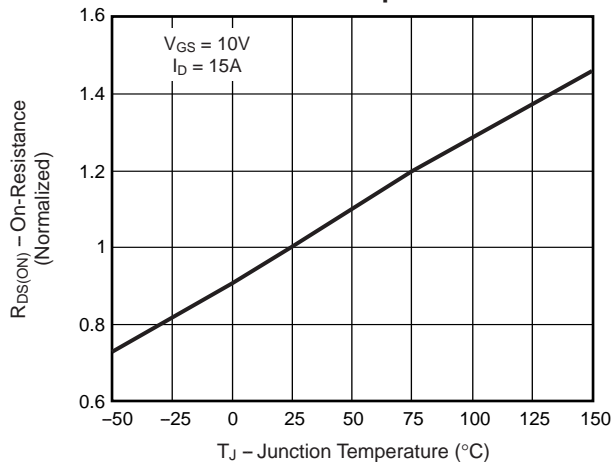

Fig. 5 – On-Resistance vs. Junction Temperature



N-Channel Enhancement-Mode MOSFET

Ratings and Characteristic Curves (T_A = 25°C unless otherwise noted)

Fig. 6 – On-Resistance vs. Gate-to-Source Voltage

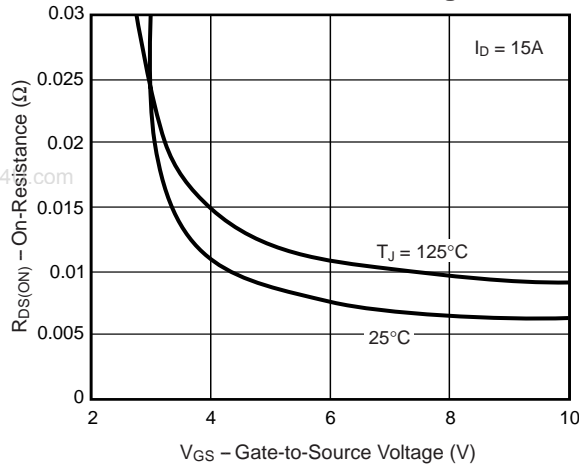

Fig. 7 – Gate Charge

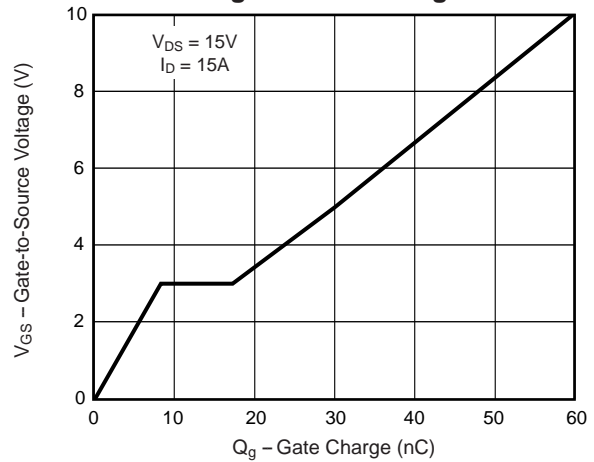

Fig. 8 – Capacitance

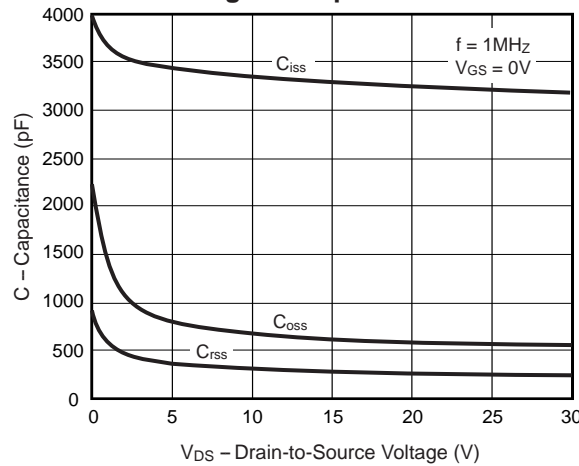
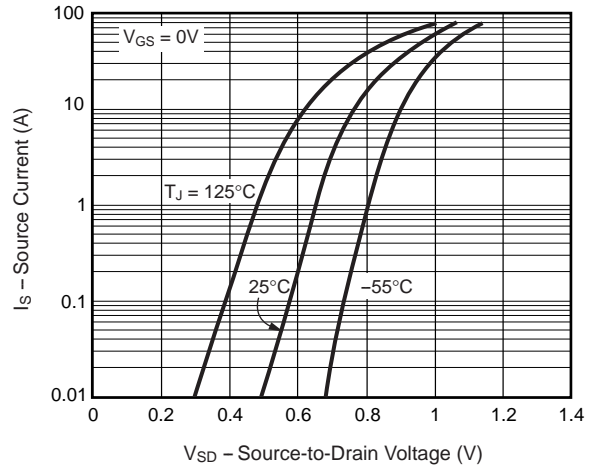

Fig. 9 – Source-Drain Diode Forward Voltage



N-Channel Enhancement-Mode MOSFET

Ratings and Characteristic Curves (T_A = 25°C unless otherwise noted)

Fig. 10 – Breakdown Voltage vs. Junction Temperature

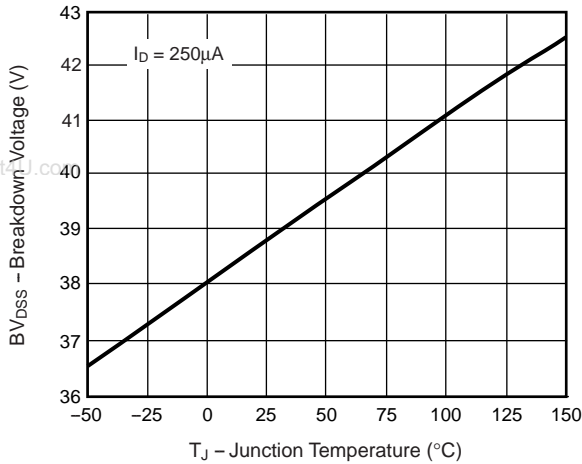

Fig. 11 – Transient Thermal Impedance

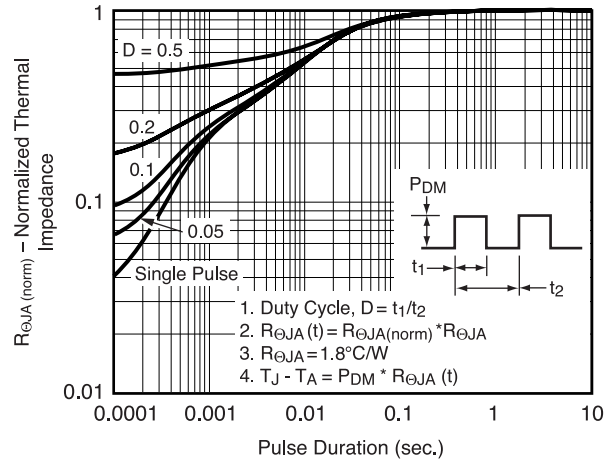

Fig. 12 – Power vs. Pulse Duration

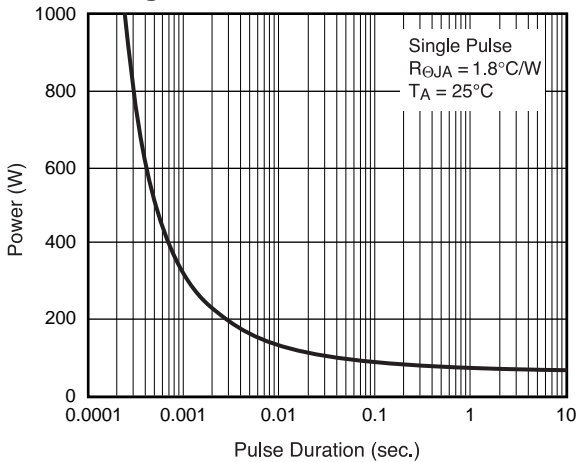
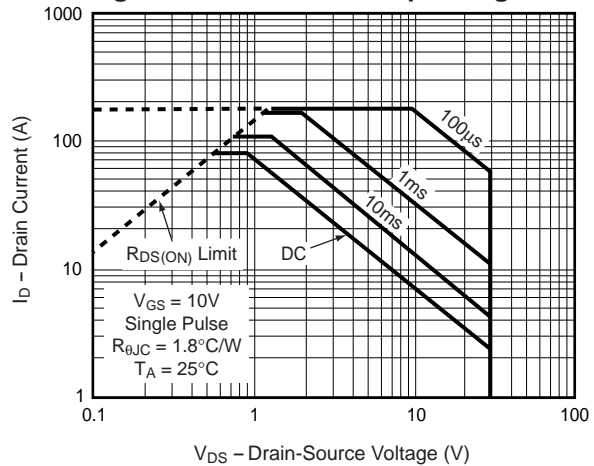

Fig. 13 – Maximum Safe Operating Area



Mouser Electronics

Authorized Distributor

Click to View Pricing, Inventory, Delivery & Lifecycle Information:

[Vishay:](#)

[GFD50N03A127C](#)