

UNCONTROLLED DOCUMENT

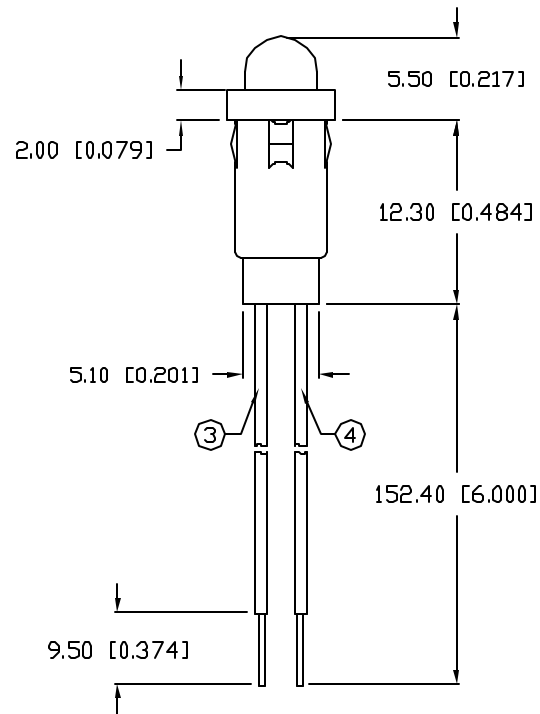

PANEL HOLE: $\varnothing 0.250^*$
PANEL THICKNESS: 0.030" MIN.

PART NUMBER
SSI-LXH600BID-150

REV.
A

REV.	E.C.N. NUMBER AND REVISION COMMENTS	DATE
A	E.C.N. #10BRDR. & REDRAWN.	7.27.01

ELECTRO-OPTICAL CHARACTERISTICS $T_A=25^{\circ}\text{C}$

PARAMETER	MIN	TYP	MAX	UNITS	TEST COND
PEAK WAVELENGTH		635 (RED)		nm	
FORWARD VOLTAGE	9-12		13	V_f	
BLINKING FREQUENCY:		1.5		Hz	$V_f=13.0, I_f=70\text{mA}$
		2.5		Hz	$V_f=3.0, I_f=6\text{mA}$
AXIAL INTENSITY		20		mcd	$V_f=9.0$
VIEWING ANGLE		60		2x theta	
EMITTED COLOR:	RED				
EPOXY LENS FINISH:	RED DIFFUSED				

LIMITS OF SAFE OPERATION AT 25°C

PARAMETER	MAX	UNITS
PEAK FORWARD CURRENT	70	mA
STEADY CURRENT	38-56	mA
POWER DISSIPATION	200	mW
DERATE FROM 25°C	-1.2	mW/ $^{\circ}\text{C}$
OPERATING, STORAGE TEMP.	-40 TO +85	$^{\circ}\text{C}$
SOLDERING TEMP.	+260	$^{\circ}\text{C}$
2.0mm FROM BODY		3 SEC. MAX

NOTES:

1. SSL-LX509F3BID LED.
2. SSH-LXH600 HOLDER, BLACK.
3. ANODE LEAD: LXP-WST24RDT0C, 24 AWG STRANDED, TOP OVERCOAT, RED INSULATION, CUT 160mm LONG, STRIP 4mm & 9.5mm.
4. CATHODE LEAD: LXP-WST24BLT0C, 24 AWG STRANDED, TOP OVERCOAT, BLACK INSULATION, CUT 160mm LONG, STRIP 4mm & 9.5mm.

UNCONTROLLED DOCUMENT

*UNLESS OTHERWISE SPECIFIED TOLERANCES PER DECIMAL PRECISION ARE: X= ± 1 (± 0.039), XX= ± 0.5 (± 0.020), XXX= ± 0.25 (± 0.010), XXXX= ± 0.127 (± 0.005). LEAD SIZE= ± 0.05 (± 0.002), LEAD LENGTH= ± 0.75 (± 0.030), MIN.= $\frac{+0.00}{-0.00}$ DECIMAL PRECISION, MAX.= $\frac{+0.00}{-0.00}$ DECIMAL PRECISION

REV.	PART NUMBER
A	SSI-LXH600BID-150

CONFIDENTIAL INFORMATION
THE INFORMATION CONTAINED IN THIS DOCUMENT IS THE PROPERTY OF LUMEX INC. EXCEPT AS SPECIFICALLY AUTHORIZED IN WRITING BY LUMEX INC, THE HOLDER OF THIS DOCUMENT SHALL KEEP ALL INFORMATION CONTAINED HEREIN CONFIDENTIAL AND SHALL PROTECT SAME IN WHOLE OR IN PART FROM DISCLOSURE AND DISSEMINATION TO ALL THIRD PARTIES.

RELIABILITY NOTE
OUR MANY YEARS OF EXPERIENCE DATA ACCUMULATION INDICATE THAT SOLDER HEAT IS A MAJOR CAUSE OF EARLY AND FUTURE FAILURE. PLEASE PAY ATTENTION TO YOUR SOLDERING PROCESS.



290 E. HELEN ROAD
PALATINE, IL 60067-6976
PHONE: +1.847.359.2790
US WEB: www.lumex.com
TW WEB: www.lumex.com.tw

T-5mm (T-1 3/4) LED, PANEL MOUNT INDICATOR, BLINKING 635nm RED LED, RED DIFFUSED LENS, WITH 6" WIRE LEADS.

DRAWN BY: GT	CHECKED BY:	APPROVED BY:	DATE: 2.5.99
			PAGE: 1 OF 1
			SCALE: N/A