



CY8CKIT-050 PSoC[®] 5 Development Kit Guide

Doc. # 001-65816 Rev. *A

Cypress Semiconductor
198 Champion Court
San Jose, CA 95134-1709
Phone (USA): 800.858.1810
Phone (Intl): 408.943.2600
<http://www.cypress.com>

Copyrights

© Cypress Semiconductor Corporation, 2011. The information contained herein is subject to change without notice. Cypress Semiconductor Corporation assumes no responsibility for the use of any circuitry other than circuitry embodied in a Cypress product. Nor does it convey or imply any license under patent or other rights. Cypress products are not warranted nor intended to be used for medical, life support, life saving, critical control or safety applications, unless pursuant to an express written agreement with Cypress. Furthermore, Cypress does not authorize its products for use as critical components in life-support systems where a malfunction or failure may reasonably be expected to result in significant injury to the user. The inclusion of Cypress products in life-support systems application implies that the manufacturer assumes all risk of such use and in doing so indemnifies Cypress against all charges.

Any Source Code (software and/or firmware) is owned by Cypress Semiconductor Corporation (Cypress) and is protected by and subject to worldwide patent protection (United States and foreign), United States copyright laws and international treaty provisions. Cypress hereby grants to licensee a personal, non-exclusive, non-transferable license to copy, use, modify, create derivative works of, and compile the Cypress Source Code and derivative works for the sole purpose of creating custom software and or firmware in support of licensee product to be used only in conjunction with a Cypress integrated circuit as specified in the applicable agreement. Any reproduction, modification, translation, compilation, or representation of this Source Code except as specified above is prohibited without the express written permission of Cypress.

Disclaimer: CYPRESS MAKES NO WARRANTY OF ANY KIND, EXPRESS OR IMPLIED, WITH REGARD TO THIS MATERIAL, INCLUDING, BUT NOT LIMITED TO, THE IMPLIED WARRANTIES OF MERCHANTABILITY AND FITNESS FOR A PARTICULAR PURPOSE. Cypress reserves the right to make changes without further notice to the materials described herein. Cypress does not assume any liability arising out of the application or use of any product or circuit described herein. Cypress does not authorize its products for use as critical components in life-support systems where a malfunction or failure may reasonably be expected to result in significant injury to the user. The inclusion of Cypress' product in a life-support systems application implies that the manufacturer assumes all risk of such use and in doing so indemnifies Cypress against all charges.

Use may be limited by and subject to the applicable Cypress software license agreement.

PSoC[®] Creator[™] is a trademark and PSoC[®] is a registered trademark of Cypress Semiconductor Corp. All other trademarks or registered trademarks referenced herein are property of the respective corporations.

Flash Code Protection

Cypress products meet the specifications contained in their particular Cypress PSoC Data Sheets. Cypress believes that its family of PSoC products is one of the most secure families of its kind on the market today, regardless of how they are used. There may be methods, unknown to Cypress, that can breach the code protection features. Any of these methods, to our knowledge, would be dishonest and possibly illegal. Neither Cypress nor any other semiconductor manufacturer can guarantee the security of their code. Code protection does not mean that we are guaranteeing the product as 'unbreakable'.

Cypress is willing to work with the customer who is concerned about the integrity of their code. Code protection is constantly evolving. We at Cypress are committed to continuously improving the code protection features of our products.

Contents



1. Introduction	5
1.1 Kit Contents	5
1.2 PSoC Creator	5
1.3 Additional Learning Resources	6
1.4 Document History	6
1.5 Documentation Conventions	6
2. Getting Started	7
2.1 Introduction	7
2.2 CD Installation	7
2.3 Install Hardware	8
2.4 Install Software	8
2.5 Uninstall Software	8
3. Kit Operation	9
3.1 Introduction	9
3.2 Programming PSoC 5 Device	9
4. Hardware	11
4.1 Kit Details	11
4.2 Functional Description	12
4.2.1 Power Supply	12
4.2.1.1 Power Supply Jumper Settings	13
4.2.1.2 Grounding Scheme	14
4.2.1.3 Low Power Functionality	14
4.2.2 Programming Interface	15
4.2.2.1 On-board Programming Interface	15
4.2.2.2 JTAG/SWD Programming	16
4.2.3 USB Communication	16
4.2.4 Boost Converter	17
4.2.5 32-kHz and 24-MHz Crystal	18
4.2.6 PSoC 5 Development Kit Expansion Ports	18
4.2.6.1 Port D	18
4.2.6.2 Port E	20
4.2.7 RS-232 Interface	21
4.2.8 Prototyping Area	21
4.2.9 Character LCD	22
4.2.10 CapSense Sensors	23
5. Example Projects	25
5.1 Project: VoltageDisplay_SAR_ADC	26
5.1.1 Project Description	26

5.1.2	Hardware Connections	26
5.1.3	SAR ADC Configuration.....	26
5.1.4	Verify Output	27
5.2	Project: VoltageDisplay_DelSigADC	27
5.2.1	Project Description.....	27
5.2.2	Hardware Connections	27
5.2.3	Del-Sig ADC Configuration	28
5.2.4	Verify Output	29
5.3	Project: IntensityLED	29
5.3.1	Project Description.....	29
5.3.2	Hardware Connections	29
5.3.3	Verify Output	29
5.4	Project: LowPowerDemo	30
5.4.1	Project Description.....	30
5.4.2	Hardware Connections	30
5.4.3	Verify Output	30
5.5	Project: CapSense.....	31
5.5.1	Project Description.....	31
5.5.2	Hardware Connections	31
5.5.3	Verify Output	32
5.6	Project: ADC_DAC	33
5.6.1	Project Description.....	33
5.6.2	Hardware Connections	33
5.6.3	Verify Output	33
A. Appendix		35
A.1	Schematic.....	35
A.2	Board Layout	40
A.2.1	PDC-09356 Top	40
A.2.2	PDC-09356 Power	41
A.2.3	PDC-09356 Ground	42
A.2.4	PDC-09356 Bottom.....	43
A.3	BOM	44

1. Introduction



Thank you for your interest in the CY8CKIT-050 PSoC[®] 5 Development Kit. This kit allows you to develop precision analog and low power designs using PSoC 5. You can design your own projects with PSoC Creator[™] or by altering sample projects provided with this kit.

The CY8CKIT-050 PSoC 5 Development Kit is based on the PSoC 5 family of devices. PSoC 5 is a Programmable System-on-Chip[™] platform for 8-bit, 16-bit, and 32-bit applications. It combines precision analog and digital logic with a high-performance CPU. With PSoC, you can create the exact combination of peripherals and integrated proprietary IP to meet your application requirements.

1.1 Kit Contents

The PSoC 5 Development Kit contains:

- Development board
- Kit CD
- Quick Start Guide
- USB A to Mini B cable
- 3.3 V LCD module

Inspect the contents of the kit; if you find any part missing, contact your nearest Cypress sales office for help.

1.2 PSoC Creator

Cypress's PSoC Creator software is a state-of-the-art, easy-to-use integrated development environment (IDE) that introduces a game-changing, hardware and software design environment based on classic schematic entry and revolutionary embedded design methodology.

With PSoC Creator, you can:

- Create and share user-defined, custom peripherals using hierarchical schematic design.
- Automatically place and route select components and integrate simple glue logic, normally located in discrete muxes.
- Trade-off hardware and software design considerations allowing you to focus on what matters and getting to market faster.

PSoC Creator also enables you to tap into an entire tools ecosystem with integrated compiler tool chains, RTOS solutions, and production programmers to support both PSoC 3 and PSoC 5.

1.3 Additional Learning Resources

Visit www.cypress.com/go/training for additional learning resources in the form of data sheets, technical reference manual, and application notes.

1.4 Document History

Revision	PDF Creation Date	Origin of Change	Description of Change
**	03/01/11	PVKV	Initial version of kit guide
*A	04/28/11	RKAD	Updated Schematic

1.5 Documentation Conventions

Table 1-1. Document Conventions for Guides

Convention	Usage
Courier New	Displays file locations, user entered text, and source code: C:\...cd\icc\
<i>Italics</i>	Displays file names and reference documentation: Read about the <i>sourcefile.hex</i> file in the <i>PSoC Designer User Guide</i> .
[Bracketed, Bold]	Displays keyboard commands in procedures: [Enter] or [Ctrl] [C]
File > Open	Represents menu paths: File > Open > New Project
Bold	Displays commands, menu paths, and icon names in procedures: Click the File icon and then click Open .
Times New Roman	Displays an equation: $2 + 2 = 4$
Text in gray boxes	Describes cautions or unique functionality of the product.

2. Getting Started



2.1 Introduction

This chapter describes how to install and configure the PSoC 5 Development Kit. Chapter 3 describes the kit operation. It explains how to program a PSoC 5 device with PSoC Programmer and use the kit with the help of an example project. To reprogram the PSoC device with PSoC Creator, refer to the CD installation instructions for PSoC Creator. Chapter 4 details the hardware operation. Chapter 5 provides instructions to create a simple example project. The Appendix section provides the schematics and BOM associated with the PSoC 5 Development Kit.

2.2 CD Installation

Follow these steps to install the PSoC 5 Development Kit software:

1. Insert the kit CD into the CD drive of your PC. The CD is designed to auto-run and the kit menu appears.

Figure 2-1. Kit Menu



Note If auto-run does not execute, double-click **AutoRun** on the root directory of the CD.



After the installation is complete, the kit contents are available at the following location:

C:\Program Files\Cypress\PSoC 5 Development Kit\1.0

2.3 Install Hardware

No hardware installation is required for this kit.

2.4 Install Software

When installing the PSoC 5 Development Kit, the installer checks if your system has the required software. These include PSoC Creator, PSoC Programmer, Windows Installer, .NET, Acrobat Reader, and KEIL Compiler. If these applications are not installed, then the installer prompts you to download and install them.

Install the following software from the kit CD:

1. PSoC Creator
2. PSoC Programmer 3.12.4 or later
Note When installing PSoC Programmer, select **Typical** on the Installation Type page.
3. Example projects (provided in the Firmware folder)

2.5 Uninstall Software

The software can be uninstalled using one of the following methods:

- Go to **Start > Control Panel > Add or Remove Programs**; select the **Remove** button.
- Go to **Start > All Programs > Cypress > Cypress Update Manager > Cypress Update Manager**; select the **Uninstall** button.
- Insert the installation CD and click **Install PSoC 5 Development Kit** button. In the **CyInstaller for PSoC 5 Development Kit 1.0** window, select **Remove** from the Installation Type drop-down menu. Follow the instructions to uninstall.

3. Kit Operation



3.1 Introduction

The PSoC 5 Development Kit examples help you develop applications using the PSoC 5 family of devices. The kit is designed to develop precision analog applications using PSoC 5. The board also has hooks to enable low power measurements for low power application development and evaluation.

3.2 Programming PSoC 5 Device

The default programming interface for the board is a USB based on-board programming interface. To program the device, plug the USB cable to the programming USB connector J1, as shown in the following figure.

Figure 3-1. Connect USB Cable to J1

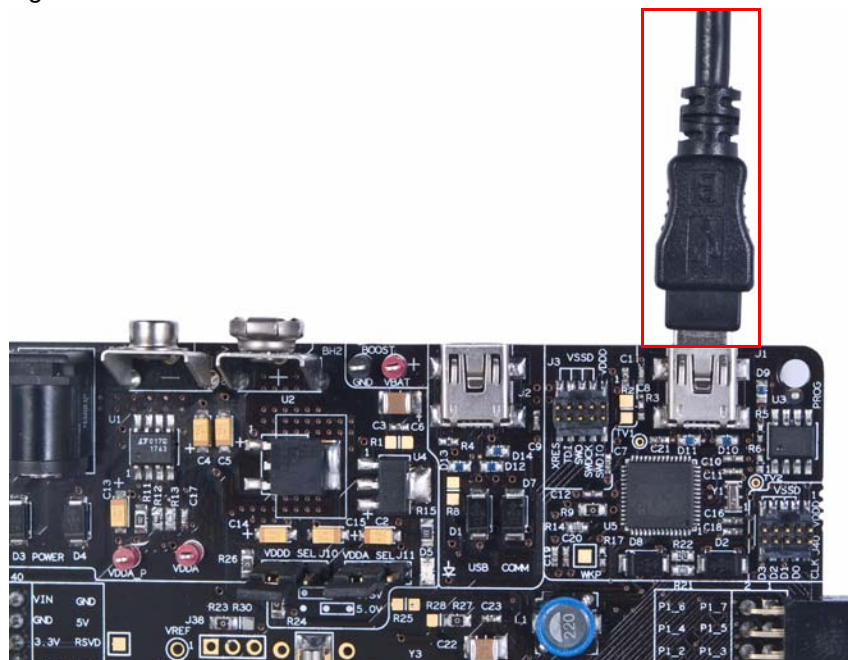

When plugged in, the board enumerates as DVKProg5. After enumeration, initiate, build, and then program using PSoC Creator.

When using on-board programming, it is not necessary to power the board from the 12-V or 9-V DC supply or a battery. The USB power to the programming section can be used.

If the board is already powered from another source, plugging in the programming USB does not damage the board.

The PSoC 5 device on the board can also be programmed using a MiniProg3 (CY8CKIT-002). To use MiniProg3 for programming, use the connector J3 on the board, as shown in the following figure.

Note The MiniProg3 (CY8CKIT-002) is not part of the PSoC 5 Development Kit contents. It can be purchased from the [Cypress Online Store](#).

Figure 3-2. Connect MiniProg

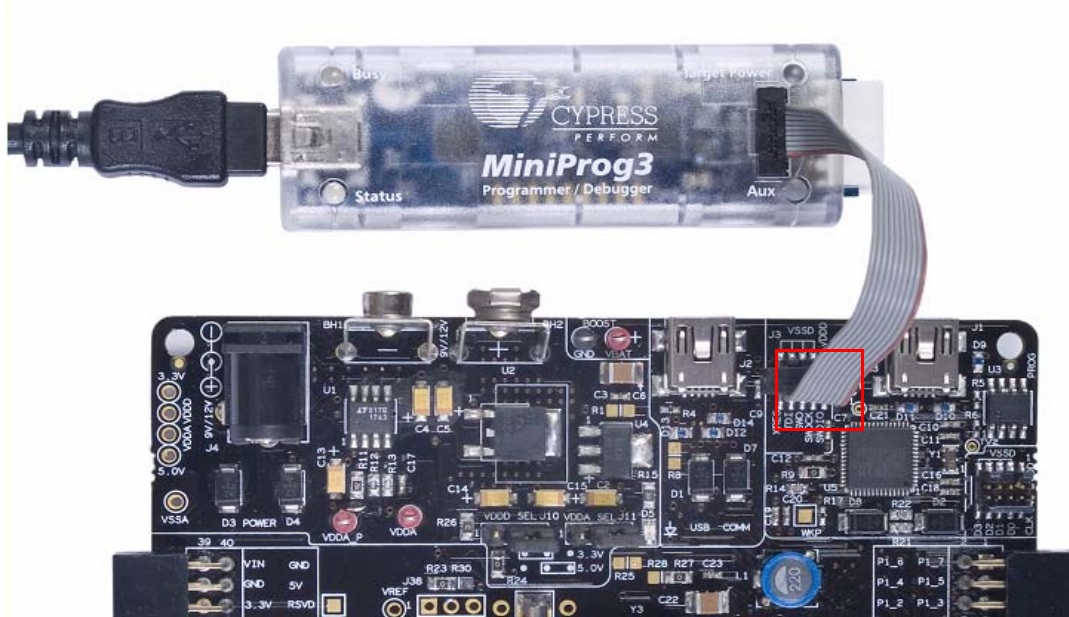

With the MiniProg3, programming is similar to the on-board programmer; however, the setup enumerates as a MiniProg3.

4. Hardware



4.1 Kit Details

The PSoC 5 Development Kit has the following sections:

- Power supply system
- Programming interface
- USB communications
- Boost convertor
- PSoC 5 and related circuitry
- 32-kHz crystal
- 24-MHz crystal
- Port E (analog performance port) and port D (CapSense® or generic port)
- RS232 communications interface
- Prototyping area
- Character LCD interface
- CapSense buttons and sliders

Figure 4-1. PSoC 5 Development Kit Details

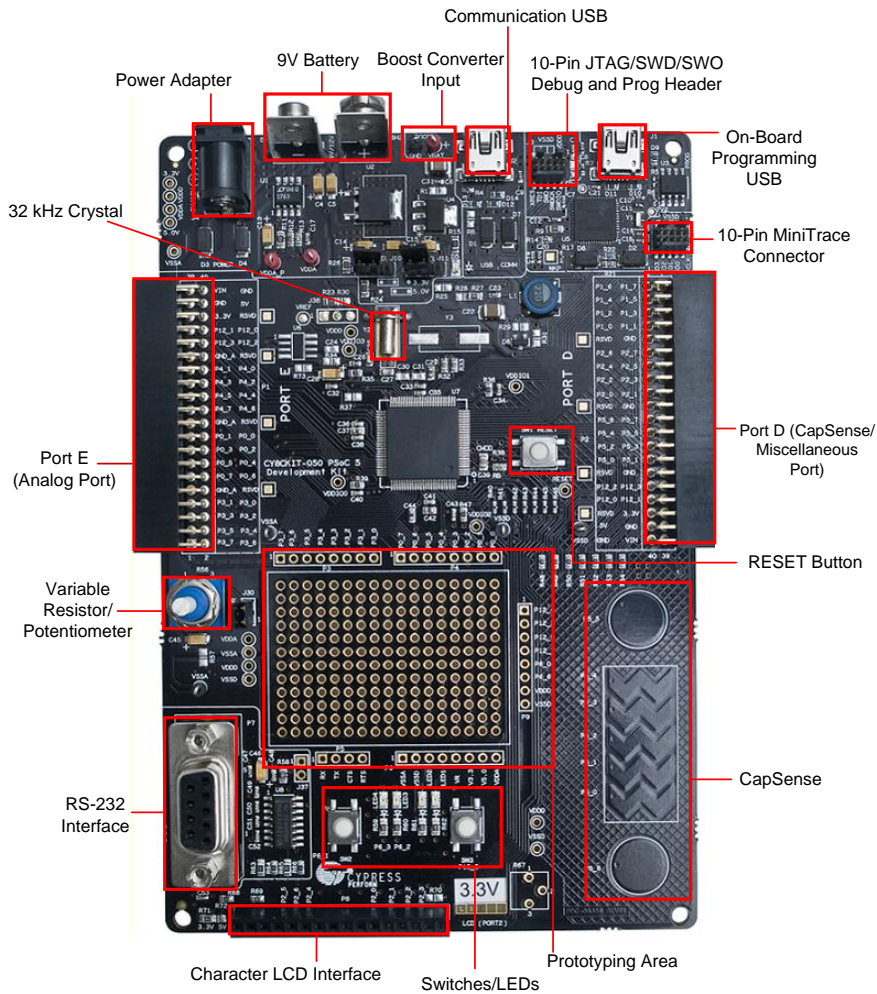

4.2 Functional Description

4.2.1 Power Supply

The power supply system on this board is versatile; input supply can be from the following sources:

- 9-V or 12-V wall wart supply using connector J4
- 9-V battery connector using connectors BH1 and BH2
- USB power from communications section using connector J2
- USB power from the on-board programming section using connector J1
- Power from JTAG/SWD programming interface using connector J3
- Power through boost converter that uses the input test points VBAT and GND

The board power domain has five rails:

- **Vin rail:** This is where the input of the on-board regulators are connected. This domain is powered through protection diodes.
- **5-V rail:** This is the output of the 5-V regulator U2. The rail is a fixed 5 V output regardless of jumper settings. The voltage in this rail can be less than 5 V only when the board is powered by the USB. This 5-V rail powers the circuits that require fixed 5 V supply.
- **3.3-V rail:** This is the output of the 3.3-V regulator U4. This rail remains 3.3 V regardless of jumper settings or power source changes. It powers the circuits requiring fixed 3.3 V supply such as the on-board programming section.
- **Vddd rail:** This rail provides power to the digital supply for the PSoC device. It can be derived from either the 5 V or 3.3 V rail. The selection is made using J10 (3-pin jumper).
- **Vdda rail:** This rail provides power to the analog supply of the PSoC device. It is the output of a low noise regulator U1. The regulator is a variable output voltage and can be either 3.3 V or 5 V. This is done by changing the position on J11 (3-pin jumper).

The following block diagram shows the structure of the power system on the board.

Figure 4-2. Power System Structure

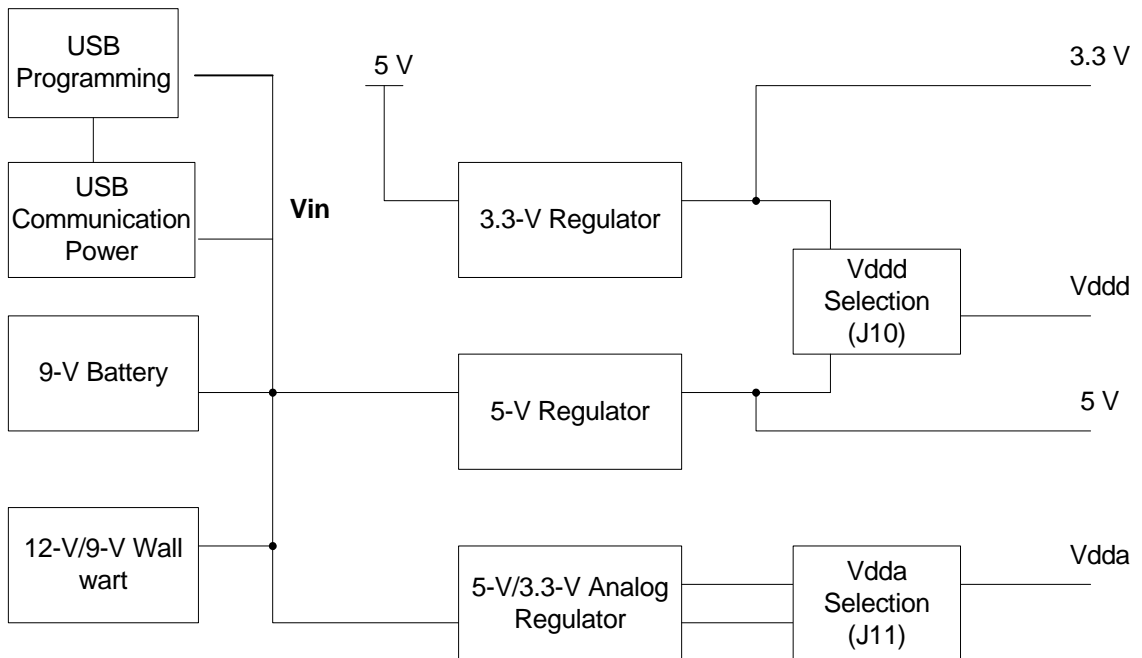

4.2.1.1 Power Supply Jumper Settings

Figure 4-3. Jumper Settings

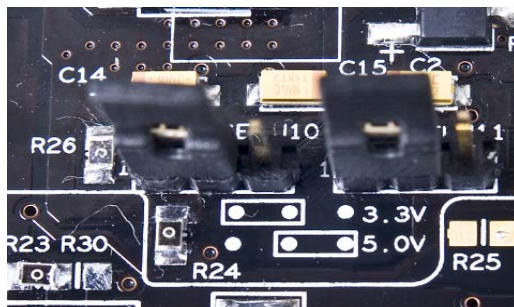

Two jumpers govern the power rails on the board. J10 is responsible for the selection of Vddd (digital power) and J11 selects Vdda (analog power).

The jumper settings for each power scheme are as follows.

Powering Scheme	Jumper Settings
Vdda = 5 V, Vddd = 5 V	J10 in 5 V setting and J11 in 5 V setting.
Vdda = 3.3 V, Vddd = 3.3 V	J10 in 3.3 V setting and J11 in 3.3 V setting.
Vdda = 5 V, Vddd = 3.3 V	J10 in 3.3 V setting and J11 in 5 V setting.
Vdda = 3.3 V, Vddd = 5 V	Can be achieved, but is an invalid condition because the PSoC 5 silicon performance cannot be guaranteed.

Warning:

- The PSoC device performance is guaranteed when Vdda is greater than or equal to Vddd. Failure to meet this condition can have implications on the silicon performance.
- When USB power is used, ensure a 3.3 V setting on both analog and digital supplies. This is because, the 5 V rail of the USB power is not accurate and is not recommended.

4.2.1.2 Grounding Scheme

The board is designed considering analog designs as major target applications. Therefore, the grounding scheme in the board is unique to ensure precision analog performance.

There are three types of ground on this board:

- GND - This is the universal ground where all the regulators are referred. Both the Vssd and Vssa connect to this ground through a star connection.
- Vssd - This is the digital ground and covers the digital circuitry present on the board, such as RS232 and LCD.
- Vssa - This is the analog ground and covers the grounding for analog circuitry present on the board, such as the reference block.

When creating custom circuitry in the prototyping area provided on the board, remember to use the Vssa for the sensitive analog circuits and Vssd for the digital ones.

Port E on the board is the designated analog expansion connector. This connector brings out ports 0, 3, and 4, which are the best performing analog ports on PSoC 3 and PSoC 5 devices. The expansion connector port E has two types of grounds. One is the analog ground (GND_A in silk screen, Vssa in the schematic), which connects directly to the analog ground on the board. The other ground known simply as GND, is used for the digital and high current circuitry on the expansion board. This differentiation on the connector grounds helps the expansion board designer to separate the analog and digital ground on any high precision analog boards being designed for port E.

4.2.1.3 Low Power Functionality

The kit also facilitates application development, which requires low power consumption. Low power functions require a power measurement capability, also available in this kit.

The analog supply is connected to the device through the zero-ohm resistor (R23). By removing this resistor and connecting an ammeter in series using the test points, Vdda_p and Vdda, you can measure the analog power used by the system.

The digital supply can be monitored by removing connection on the jumper J10 and connecting an ammeter in place of the short. This allows to measure the digital power used by the system.

The board provides the ability to measure analog and digital power separately. To measure power at a single point, rather than at analog and digital separately, remove the resistor R23 to disconnect the analog regulator from powering the Vdda and short Vdda and Vddd through R30. Now, the net power can be measured at the J10 jumper similar to the digital power measurement. To switch repeatedly between R23 and R30, moving around the zero-ohm resistors can be discomfoting. Hence, a J38 (unpopulated) is provided to populate a male 3-pin header and have a shorting jumper in the place of R23/R30.

While measuring device power, make the following changes in the board to avoid leakage through other components that are connected to the device power rails.

- Disconnect the RS232 power by disconnecting R58. An additional jumper capability is available as J37 if you populate it with a 2-pin male header.
- Disconnect the potentiometer by disconnecting J30.
- Ground the boost pins if boost operation is not used by populating R1, R28, and R29. Also make sure R25 and R31 are not populated.

4.2.2 Programming Interface

This kit allows programming in two modes:

- Using the on-board programming interface
- Using the JTAG/SWD programming interface that uses a MiniProg3

4.2.2.1 On-board Programming Interface

The on-board programmer interfaces with your PC through a USB connector marked as On-Board Programming USB in [Figure 4-1](#).

Figure 4-4. On-board Programming Interface

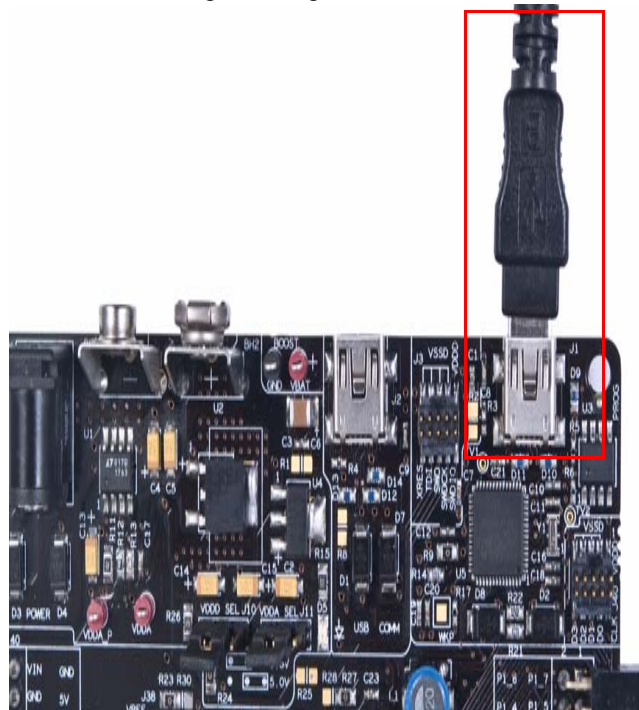

When the USB programming is plugged into the PC, it enumerates as DVKProg5 and you can use the normal programming interface from PSoC Creator to program this board through the on-board programmer.

A zero-ohm resistor R9 is provided on the board to disconnect power to the on-board programmer.

4.2.2.2 JTAG/SWD Programming

Apart from the on-board programming interface, the board also provides the option of using the MiniProg3. This interface is much faster than the on-board program interface. The JTAG/SWD programming is done through the 10-pin connector, J3.

Figure 4-5. JTAG/SWD Programming

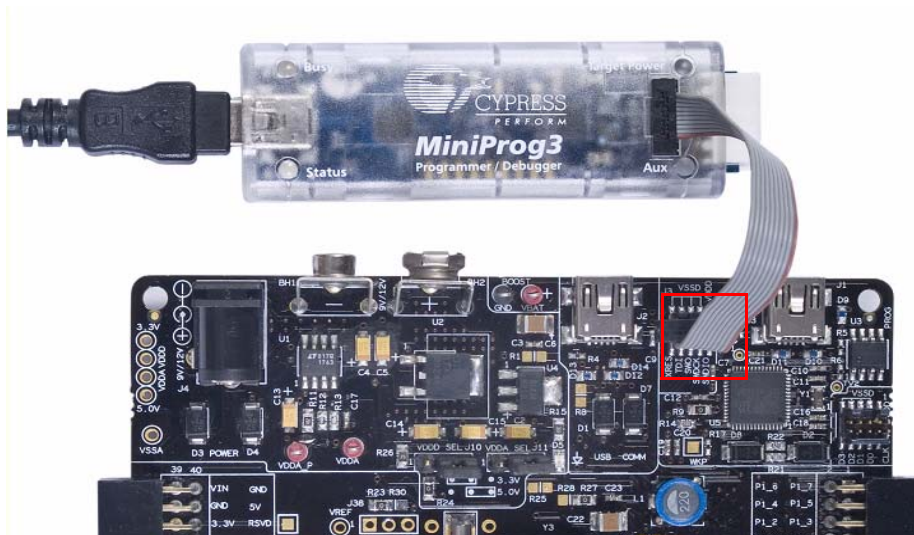

The JTAG/SWD programming using J3 requires the programmer, which can be purchased from <http://www.cypress.com/go/CY8CKIT-002>.

4.2.3 USB Communication

The board has a USB communications interface that uses the connector as shown in [Figure 4-6](#). The USB connector connects to the D+ and D- lines on the PSoC to enable development of USB applications using the board. This USB interface can also supply power to the board as discussed in [Power Supply on page 12](#).

Figure 4-6. USB Interface

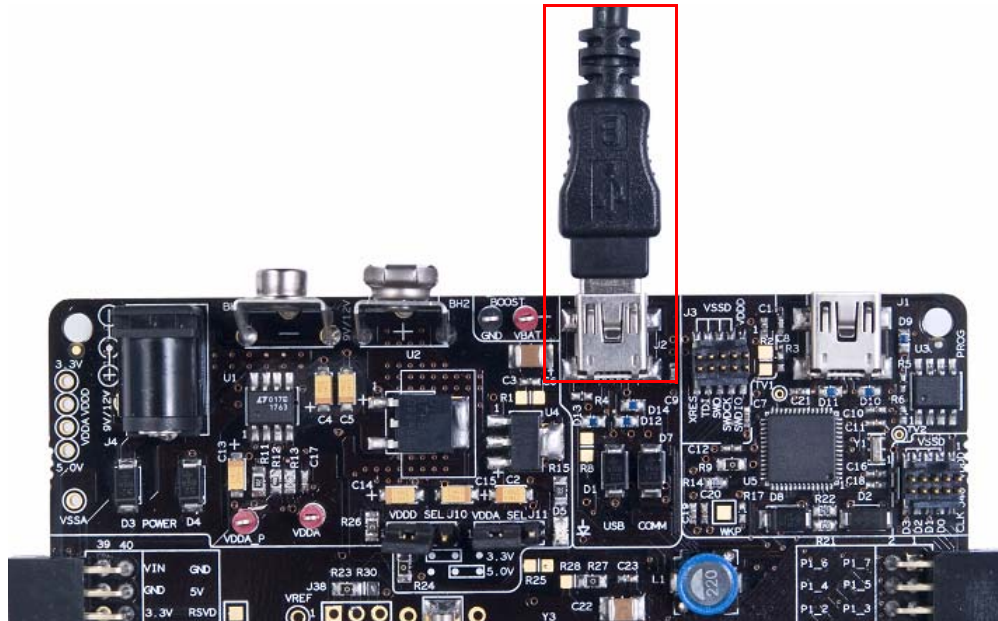

4.2.4 Boost Converter

The PSoC 5 device has a unique capability of working from a voltage supply as low as 0.5 V. This is possible using the boost converter. The boost converter uses an external inductor and a diode. These components are pre-populated on the board. [Figure 4-7](#) shows the boost converter.

To enable the boost converter functionality, make the following hardware changes on the board.

- Populate resistors R25, R27, R29, and R31
- Ensure that R1 and R28 are not populated

After making these changes, you can make a boost converter based design by making the appropriate configurations in the project. The input power supply to the boost converter must be provided through the test points marked Vbat and GND.

Note Due to a silicon defect, the boost circuitry works only for input greater than 1.8 V.

Figure 4-7. Boost Converter

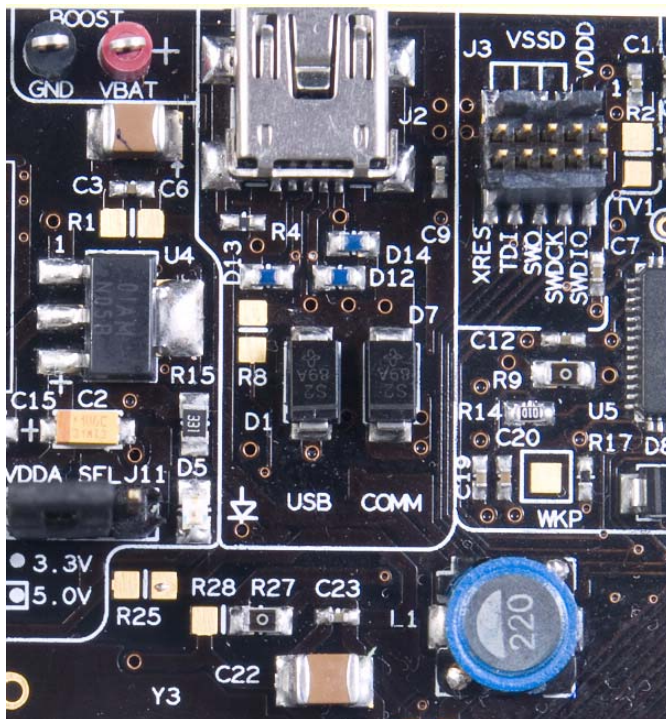

4.2.5 32-kHz and 24-MHz Crystal

PSoC 5 has an on-chip Real Time Clock (RTC), which can function in sleep. This requires an external 32-kHz crystal, which is provided on board to facilitate RTC based designs. The PSoC 5 also has an option for an external MHz crystal in applications where the IMO tolerance is not satisfactory. In these applications, the board has a 24-MHz crystal to provide an accurate main oscillator.

Note The 24-MHz crystal circuitry is not populated on the board by default.

4.2.6 PSoC 5 Development Kit Expansion Ports

The PSoC 5 Development Kit has two expansion ports, Port D and Port E, each with their own unique features.

4.2.6.1 Port D

This is the miscellaneous port on the board. It is designed to handle CapSense based application boards and digital application boards. The signal routing to this port adheres to the stringent requirements posed to provide good performance CapSense. This port can also be used for other functions and Expansion Board Kits (EBKs).

This port is not designed for precision analog performance. The pins on the port are functionally compatible to port B of the PSoC Development Kit. So any project made to function on port B of the PSoC Development Kit can be easily ported over to port D on this board. A caveat to this is that there is no opamp available on this port; therefore, opamp based designs are not recommended for use on this port.

The following figure shows the pin mapping for the port.

Figure 4-8. Port D

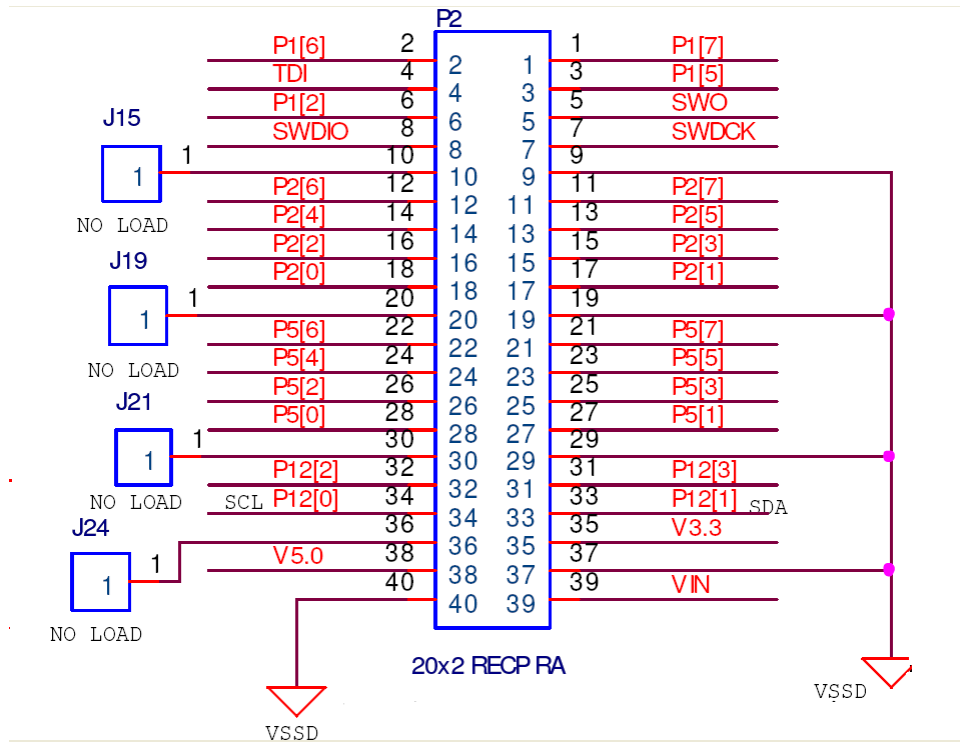
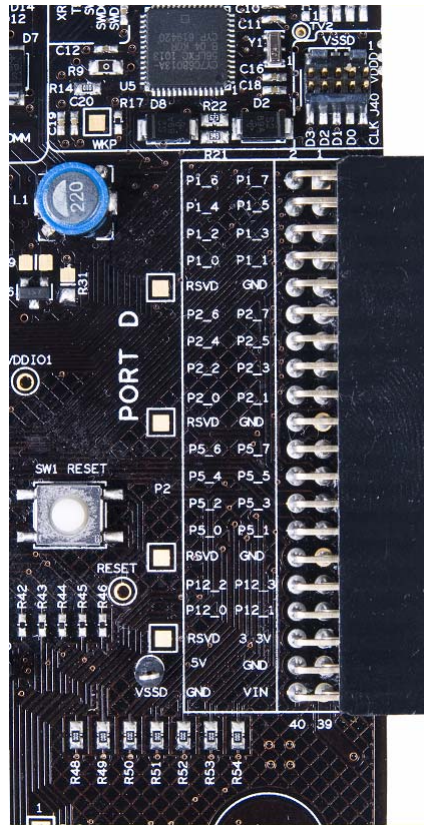

4.2.6.2 Port E

This is the analog port on this kit and has special layout considerations. It also brings out all analog resources such as dedicated opamps to a single connect. Therefore, this port is ideal for precision analog design development. This port is functionally compatible to port A of the PSoC Development Kit and it is easy to port application developed on port A.

There are two types of grounds on this port, CGND1 and CGND2. The two grounds are connected to the GND on the board, but are provided for expansion boards designed for analog performance. The expansion boards have an analog and digital ground. The two grounds on this port help to keep it distinct even on this board until it reaches the GND plane.

Figure 4-9. Port E

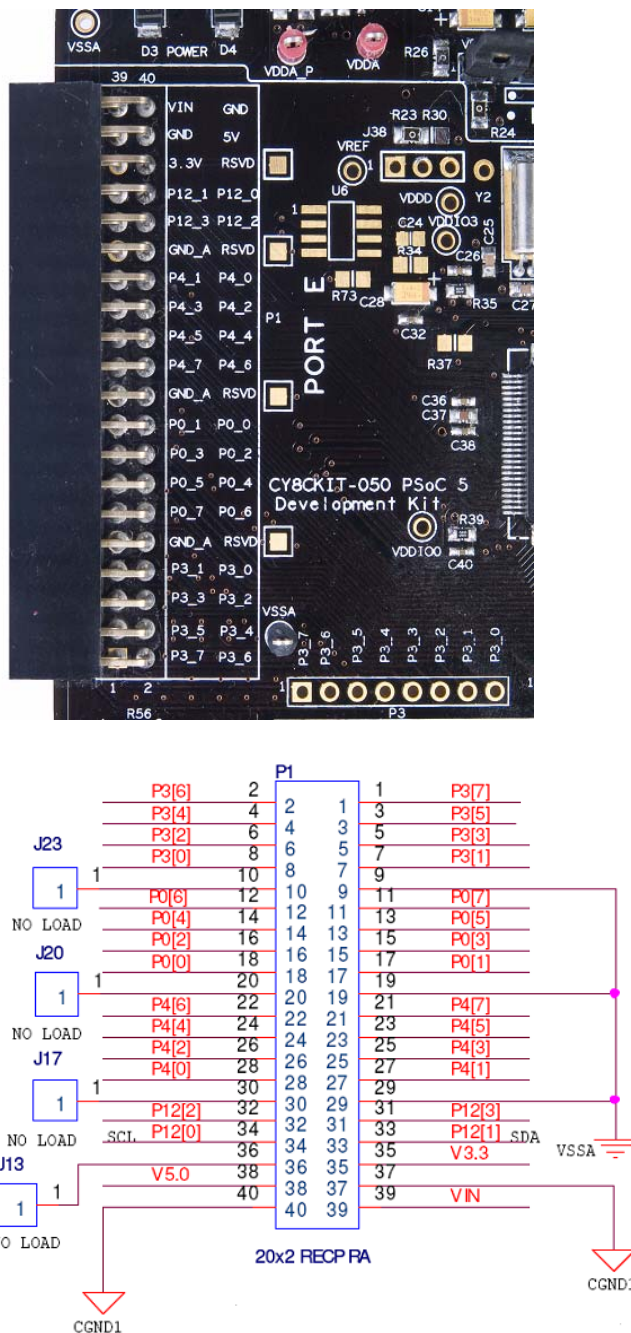

4.2.7 RS-232 Interface

The board has an RS-232 transceiver on board for designs using RS-232 (UART). The RS-232 section power can be disconnected through a single resistor R58. This is useful for low-power designs.

Figure 4-10. RS-232 Interface

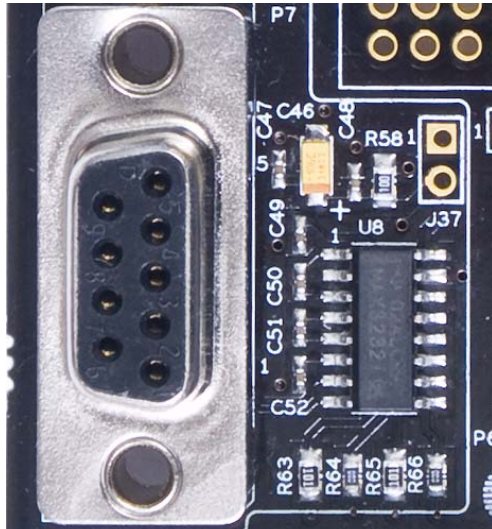

4.2.8 Prototyping Area

The prototyping area on the board has two complete ports of the device for simple custom circuit development. The ports in the area are port 0 and port 3, which bring out the four dedicated opamp pins on the device. Therefore, these ports can be used with the prototyping area to create simple yet elegant analog designs. It also brings SIOs such as port 12[4], port 12[5], port 12[6], and port 12[7] and GPIOs such as port P6[0] and port P6[6]. There is power and ground connections close to the prototyping space for convenience.

The area also has four LEDs and two switches for applications development. The two switches on the board are hard-wired to port 15[5] and port 6[1]. Two LEDs out of the four are hard-wired to port 6[2] and port 6[3] and the other two are brought out on pads closer to the prototyping area.

Figure 4-11. Prototyping Area

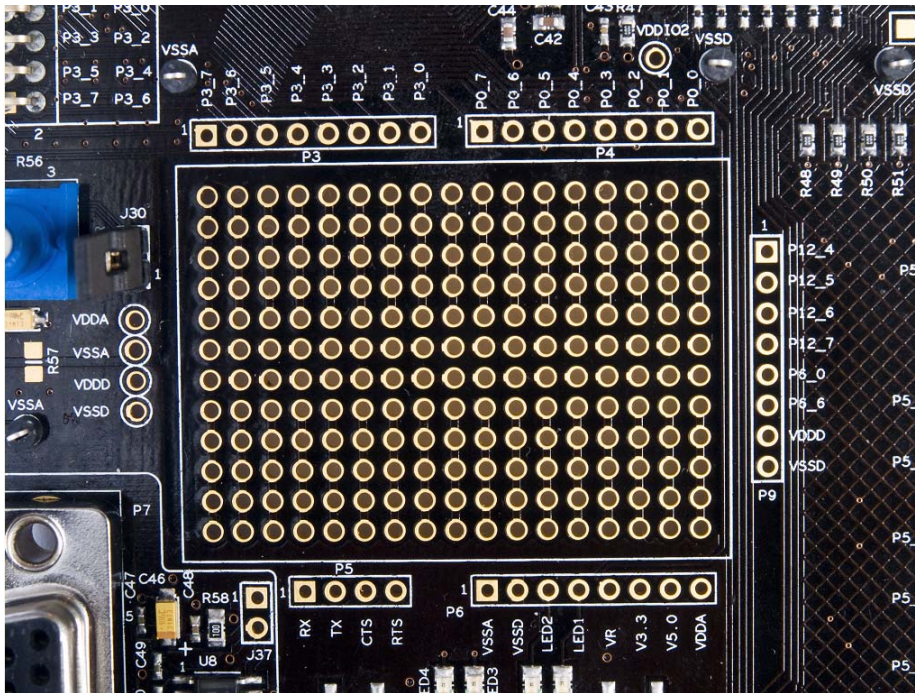

This area also comprises of a potentiometer to be used for analog system development work. The potentiometer connects from Vdda, which is a noise free supply and is hence capable of being used for low noise analog applications. Potentiometer output is available on P6[5] and VR on header P6 in prototyping area.

4.2.9 Character LCD

The kit has a character LCD module, which goes into the character LCD header, P8. The LCD runs on a 3.3-V supply and can function regardless of the voltage on which PSoC is powered. There is a zero-ohm resistor setting available on the LCD section (R71/72), making it possible to convert it to a 3.3V LCD.

CAUTION: When the resistor is shifted to support a 5 V LCD module, plugging in a 3.3 V LCD module into the board can damage the LCD module.

Figure 4-12. Pin-1 Indication

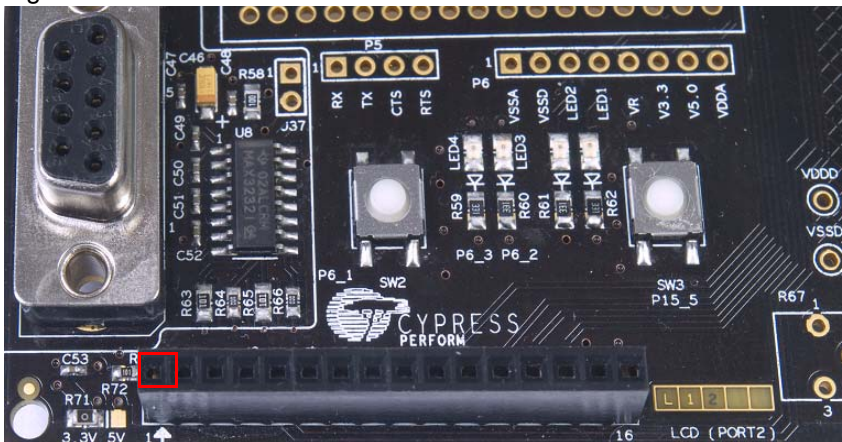
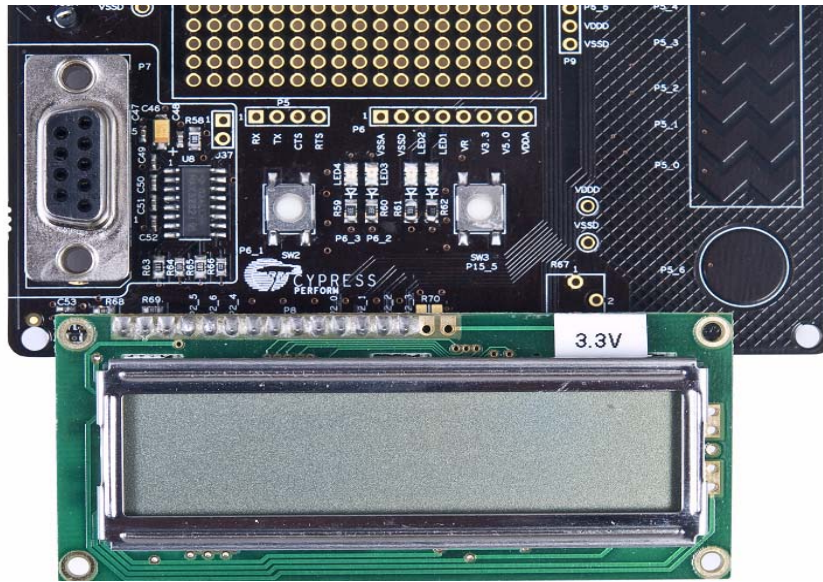

Figure 4-13. LCD Connected on P8 Connector



4.2.10 CapSense Sensors

The board layout has considered the special requirements for CapSense. It has two CapSense buttons and a 5-element CapSense slider. The CapSense buttons are connected to pins P5[6] and P5[5]. The slider elements are connected to pins P5[0:4].

The Cmod (modulation capacitor) is connected to pin P6[4] and an optional Rb (bleeder resistor) is available on P15[4].

5. Example Projects



To access example projects described in this section, open the PSoC Creator start page. For additional example projects, visit <http://www.cypress.com>.

Figure 5-1. PSoC Creator Start Page

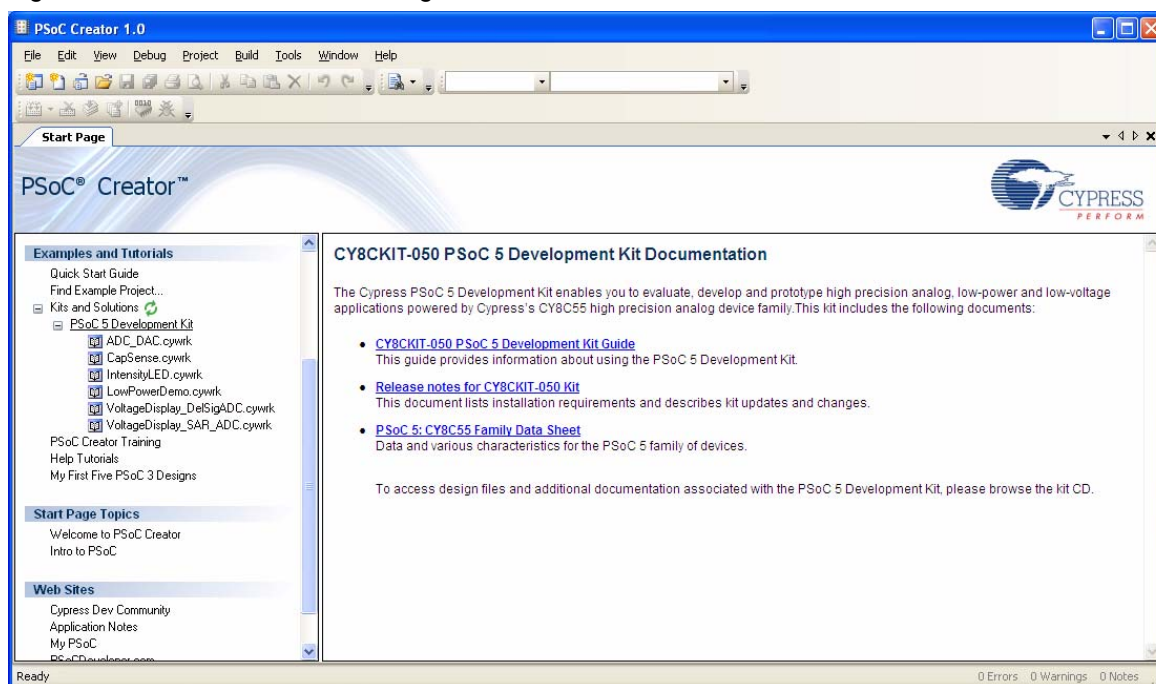

Follow these steps to open and program example projects:

1. Click on **Example Projects** from **Kits and Solutions** on the PSoC Creator Start page.
2. Create a folder in the desired location and click **OK**.
3. The project opens in PSoC Creator and is saved to that folder.
4. Build the example project to generate the .hex file.
5. To program the example projects, power the board using the instructions in [On-board Programming Interface on page 15](#).
6. To program the board, click **Debug > Program**.

5.1 Project: VoltageDisplay_SAR_ADC

5.1.1 Project Description

This example code measures an analog voltage controlled by the potentiometer. The code uses the internal SAR ADC configured for a 12-bit operation; the ADC range is 0 to V_{dda}. The results are displayed on the character LCD.

Note The PSoC 5 Development Kit is factory-programmed with this example.

5.1.2 Hardware Connections

The example requires the character LCD on P8. Because it uses the potentiometer, the jumper POT_PWR should be in place. This connects the potentiometer to the V_{dda}.

5.1.3 SAR ADC Configuration

Figure 5-2. SAR ADC Configuration

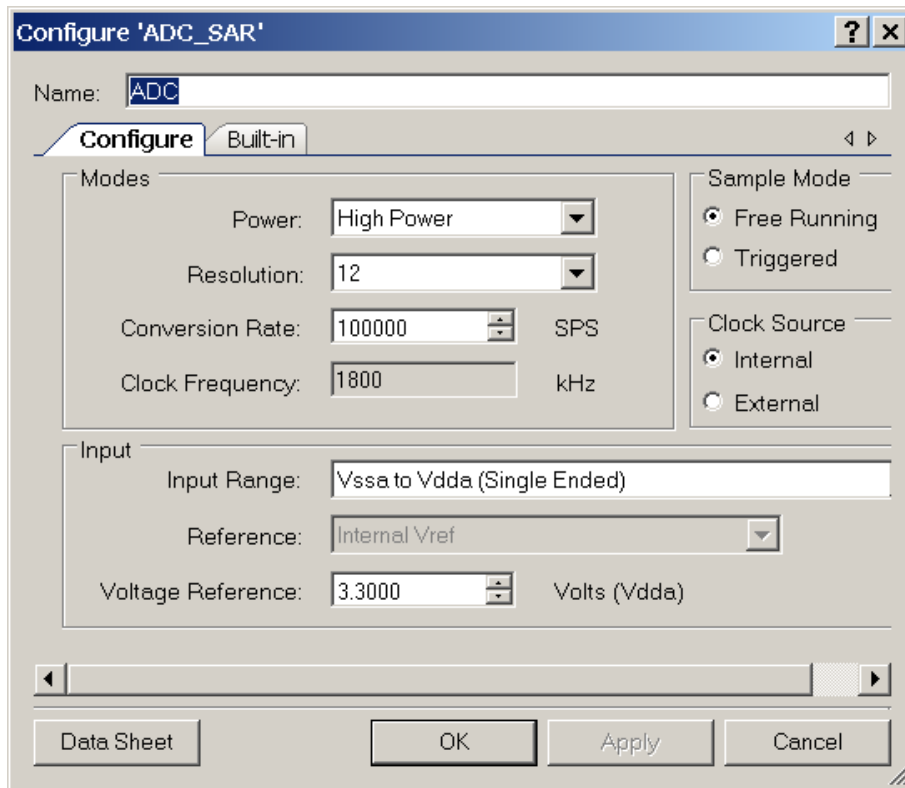

The SAR ADC is configured as follows:

- Free Running mode of operation is selected because the ADC scans only one channel continuously.
- Conversion rate is set to 100 ksps. The code waits for each sample, processes it, and displays the result on the LCD.
- Range is set to V_{ssa} to V_{dda} in single-ended mode because the potentiometer output is a single ended signal that can go from 0 to V_{dda}. Therefore, at 12-bit resolution, the ADC will resolve in steps of $V_{dda}/2^{12}$.

- Voltage Reference should be set to Vdda supply voltage when Input Range is set to 'Vssa to Vdda'. It is set to 3.3 V here, because by default Vdda jumper setting on the board is set to 3.3 V. If J11 is changed to select 5 V then this parameter should be changed to 5 V accordingly.

5.1.4 Verify Output

Build and program the example project and reset the device. The LCD shows the voltage reading corresponding to the voltage on the potentiometer. [Figure 5-3](#) demonstrates the functionality. When you turn the potentiometer, the voltage value changes. You can also verify the voltage on the potentiometer using a precision multimeter.

Note The potentiometer connects to a differential ADC, which works in single ended mode. This means the ADC input is measured against internal Vssa. Any offset in the measurement can be positive or negative. This can result in a small offset voltage even when the potentiometer is zero.

Figure 5-3. Voltage Display using SAR ADC

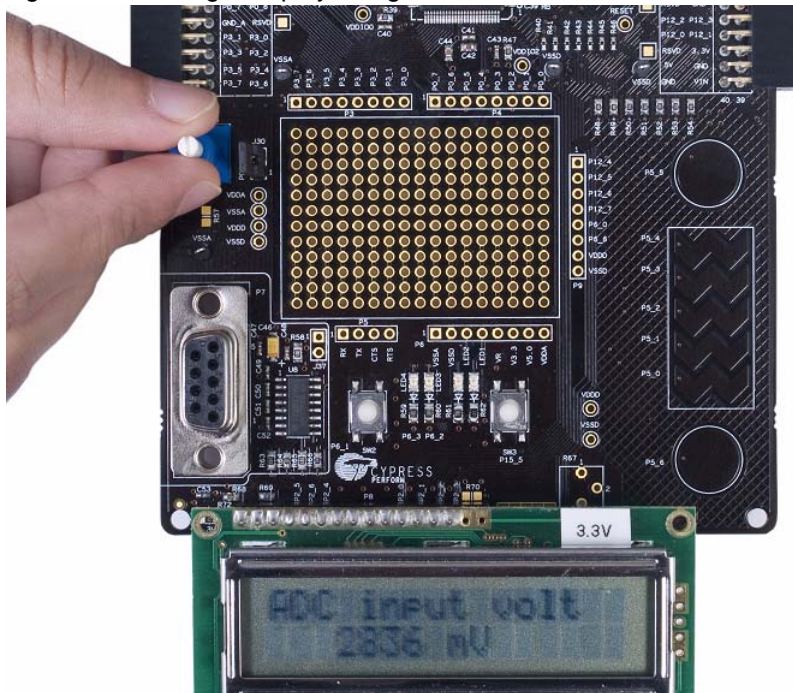

5.2 Project: VoltageDisplay_DeISigADC

5.2.1 Project Description

This example code measures a simple analog voltage controlled by the potentiometer. The code uses the internal DeI-Sig ADC configured for a 20-bit operation; the ADC range is 0 to Vdda. The voltage measurement resolution is in microvolts. The results are displayed on the character LCD module.

5.2.2 Hardware Connections

The example requires the character LCD on P8. Because it uses the potentiometer, the jumper POT_PWR should be in place. This connects the potentiometer to the Vdda.

5.2.3 Del-Sig ADC Configuration

Figure 5-4. Delta-Sigma ADC Configuration

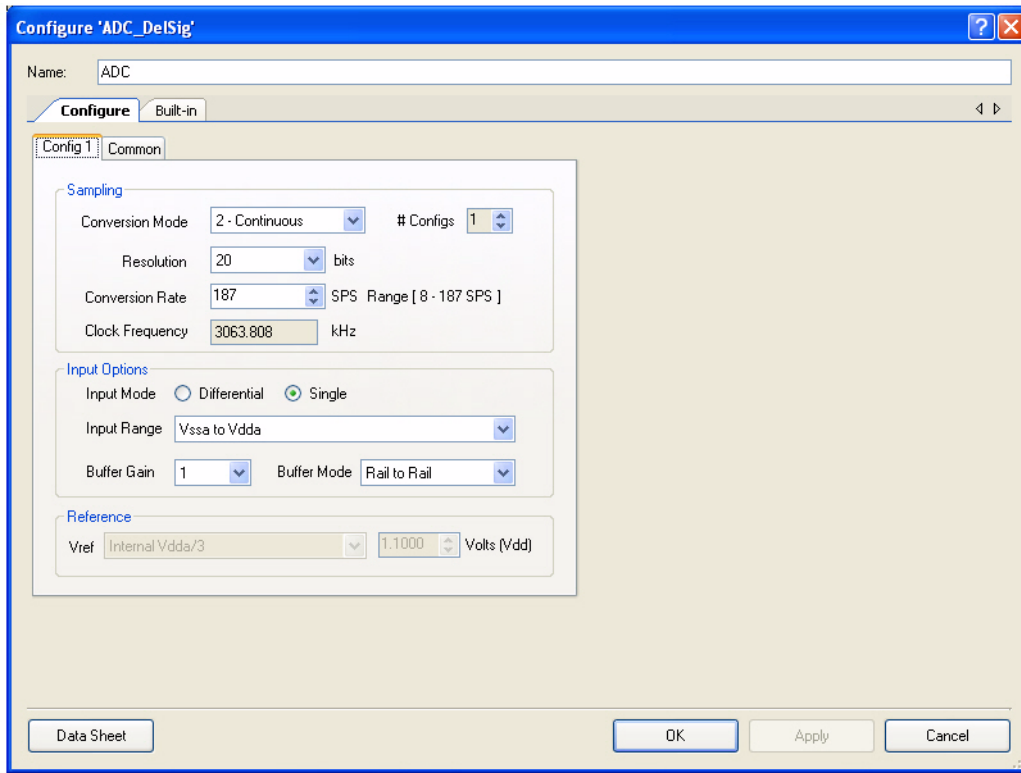

The Del-Sig ADC is configured as follows:

- Continuous mode of operation is selected because the ADC scans only one channel.
- Conversion rate is set to 187 samples/sec, which is the maximum sample rate possible at 20-bit resolution.
- Range is set to Vssa to Vdda in single ended mode because the potentiometer output is a single ended signal that can go from 0 to Vdda. Therefore, at 20-bit resolution, the ADC will resolve in steps of Vdda/220.

Note Internal Vdda/3 Reference option is not available in the current PSoC 5 silicon. In this project, Vdda = 5 V. The project will not work if Vdda = 3.3 V, because it needs Vdda/3 reference for DelSig ADC. To set Vdda to 5 V, in the VoltageDisplay_DelSigADC.cydwr window of PSoC Creator, click on the **System** tab, go to **Voltage Configuration** options. Set Vdda to 5 V.



Option	Type	Value
Vddi	FLOAT	5
Vdda	FLOAT	5
Vdda0	FLOAT	5
Vdda1	FLOAT	5
Vdda2	FLOAT	5
Vdda3	FLOAT	5

5.2.4 Verify Output

Build and program the example project and reset the device. The LCD shows the voltage reading corresponding to the voltage on the potentiometer. [Figure 5-5](#) demonstrates the functionality. When you turn the potentiometer, the voltage value changes. You can also verify the voltage on the potentiometer using a precision multimeter.

Note The potentiometer connects to a differential ADC, which works in single ended mode. This means the ADC input is measured against internal V_{ssa} . Any offset in the measurement can be positive or negative. This can result in a small offset voltage even when the potentiometer is zero.

Figure 5-5. Voltage Display using Del-Sig ADC

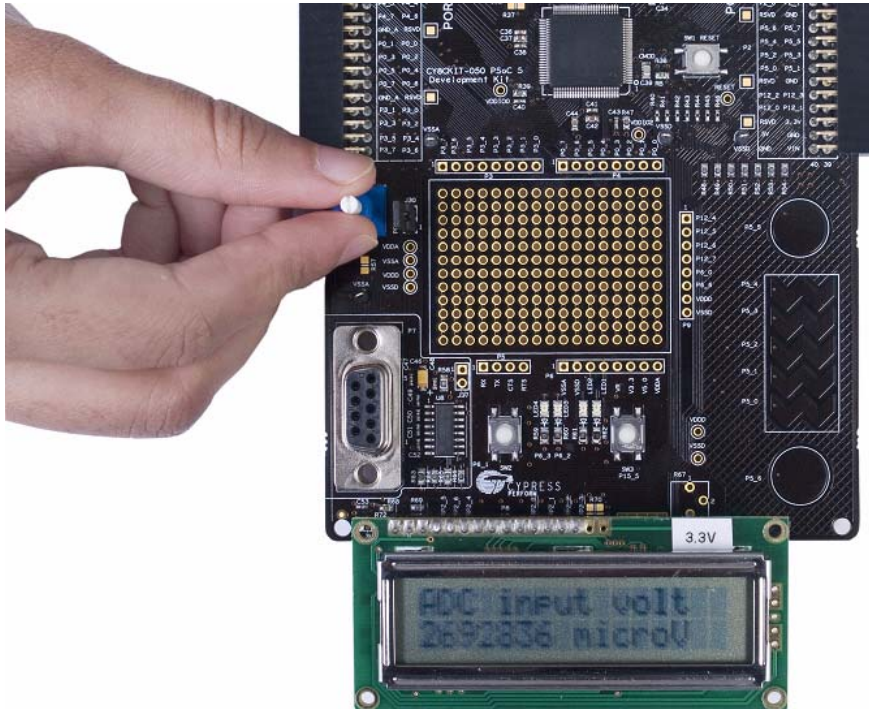

5.3 Project: IntensityLED

5.3.1 Project Description

This example code uses a pulse width modulator (PWM) to illuminate an LED. When the pulse width of the PWM varies, the LED brightness changes. By continuously varying the pulse width of the PWM, the example code makes an LED go from low brightness to a high brightness and back.

5.3.2 Hardware Connections

No hardware connections are required for this project, because all the connections are hard wired to specific pins on the board.

5.3.3 Verify Output

When the example code is built and programmed into the device, reset the device by pressing the RESET button or power cycling the board.

The project output is LED3 glowing with a brightness control that changes with time (see [Figure 5-6](#)).

Figure 5-6. Verify Output - Example Project

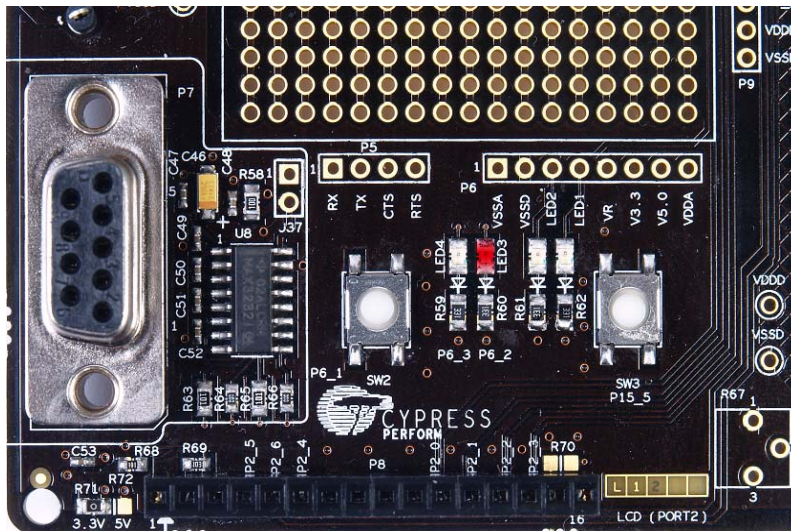

5.4 Project: LowPowerDemo

5.4.1 Project Description

This example project demonstrates the low power functionality of PSoC 5. The project implements an RTC based code, which goes to sleep and wakes up on the basis of switch inputs.

The RTC uses an accurate 32-kHz clock generated using the external crystal provided on the board.

When there is a key press, the device is put to sleep while the RTC is kept active.

5.4.2 Hardware Connections

The project requires a 3.3 V LCD to view the time display. No extra connections are required for project functionality. To make low power measurements using this project, refer and implement the changes proposed in [Low Power Functionality on page 14](#).

5.4.3 Verify Output

In normal operation, the project displays the time starting from 00:00:00. When you press the SW2 button, the device is put to sleep. If an ammeter is connected to measure the system current (refer [Low Power Functionality on page 14](#) for details), a system current of less than 2 μA is displayed.

The device wakes up when SW2 is pressed again and displays the time on the LCD. The following figures show the output display.

Figure 5-7. PSoC 5 in Active Mode

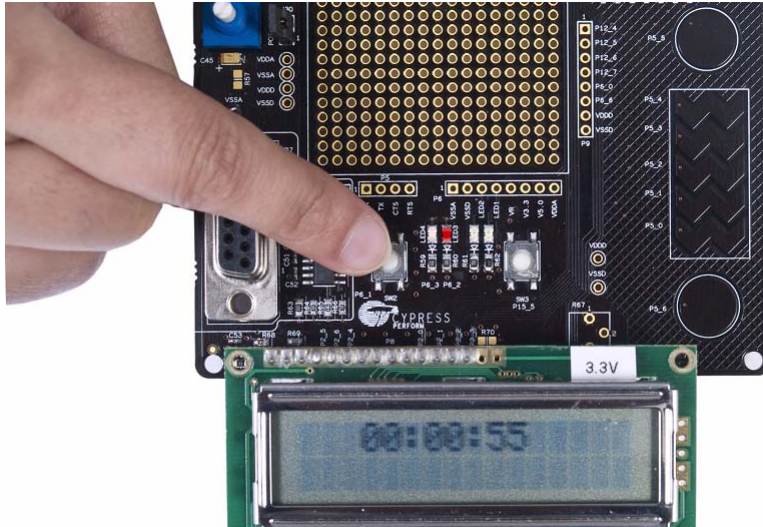
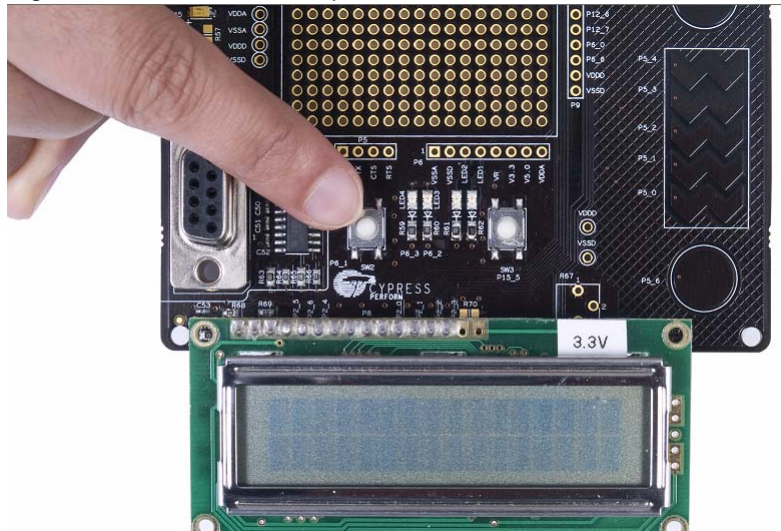

Figure 5-8. PSoC 5 in Sleep Mode



5.5 Project: CapSense

5.5.1 Project Description

This example project provides a platform to build CapSense based projects using PSoC 5. The example uses two CapSense buttons and one 5-element slider provided on the board. Each capacitive sensor on the board is scanned using the Cypress CSD algorithm. The buttons are pre-tuned in the example code to take care of factors such as board parasitic.

5.5.2 Hardware Connections

This project uses the LCD for display; therefore, ensure that it is plugged into the port. There are no specific hardware connections required for this project because all connections are hard wired on the board.

5.5.3 Verify Output

Build and program the example project and reset the device. The LCD displays the status of the two buttons as ON/OFF. The LCD also shows the slider touch position as a percentage. When you touch a button, the LCD displays ON; when you remove the finger from the button, the LCD displays OFF. When the slider is touched, the corresponding finger position is displayed as a percentage on the LCD.

Figure 5-9. CapSense Slider

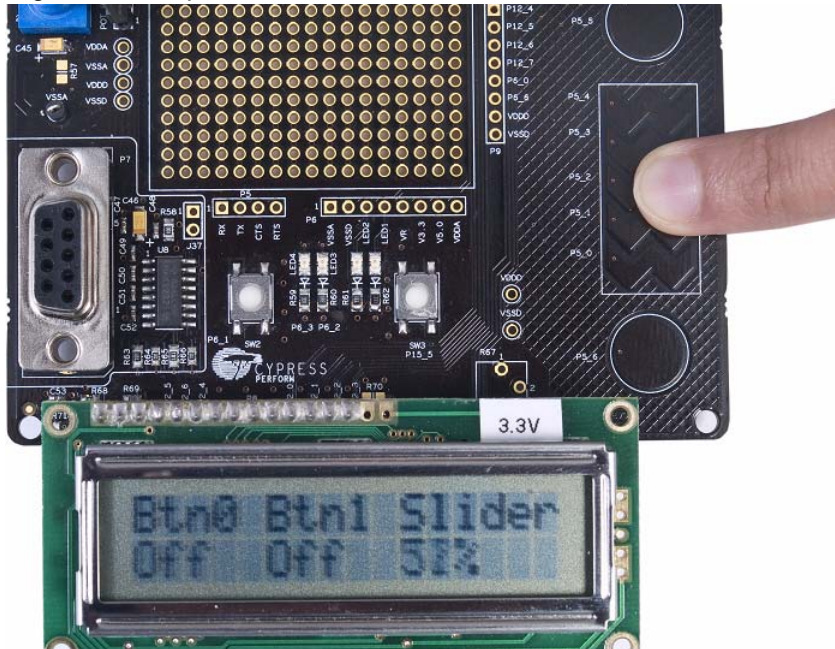
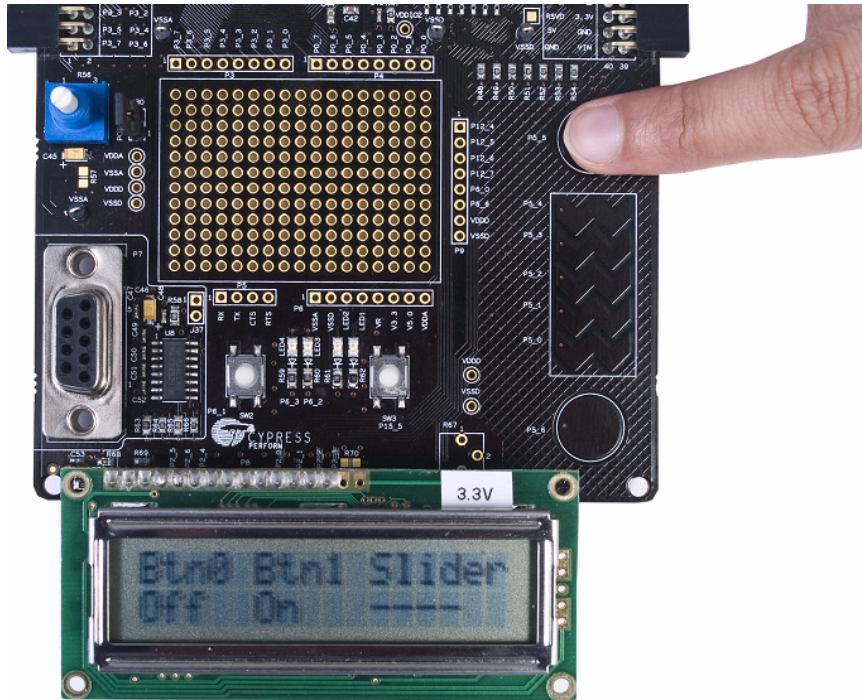

Figure 5-10. CapSense Button



5.6 Project: ADC_DAC

5.6.1 Project Description

This project demonstrates sine wave generation by using an 8-bit DAC and DMA. The sine wave period is based on the current value of the ADC value of the potentiometer.

The firmware reads the voltage output by the board potentiometer and displays the raw counts on the board character LCD display. An 8-bit DAC outputs a table generated sine wave to an LED using DMA at a frequency proportional to the ADC count.

5.6.2 Hardware Connections

For this example, the character LCD must be installed on P8. The example uses the potentiometer; therefore, the jumper POT_PWR should also be in place. This jumper connects the potentiometer to the Vdda.

5.6.3 Verify Output

Build, program the device, and press the **Reset** button on the PSoC 5 Development Kit to see the ADC output displayed on the LCD. LED4 is an AC signal output whose period is based on the ADC. Turning the potentiometer results in LCD value change. This also results in change in the period of the sine wave fed into LED4. When the potentiometer changes, the blinking rate of LED4 changes.

Figure 5-11. ADC Output

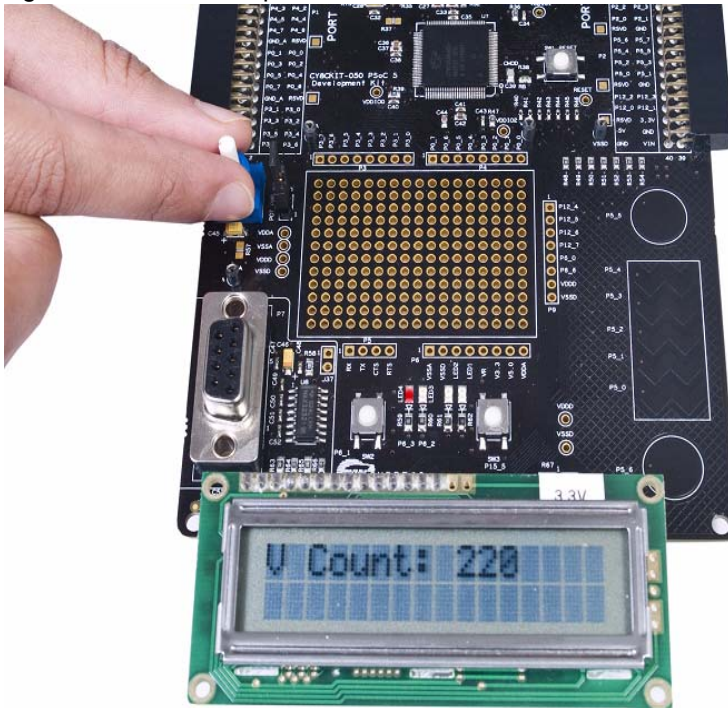

A. Appendix



A.1 Schematic

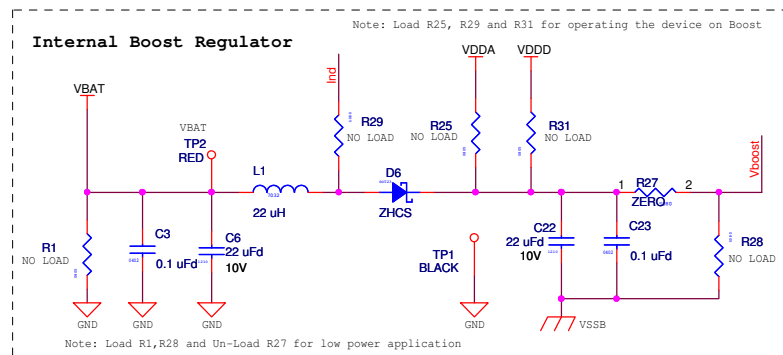
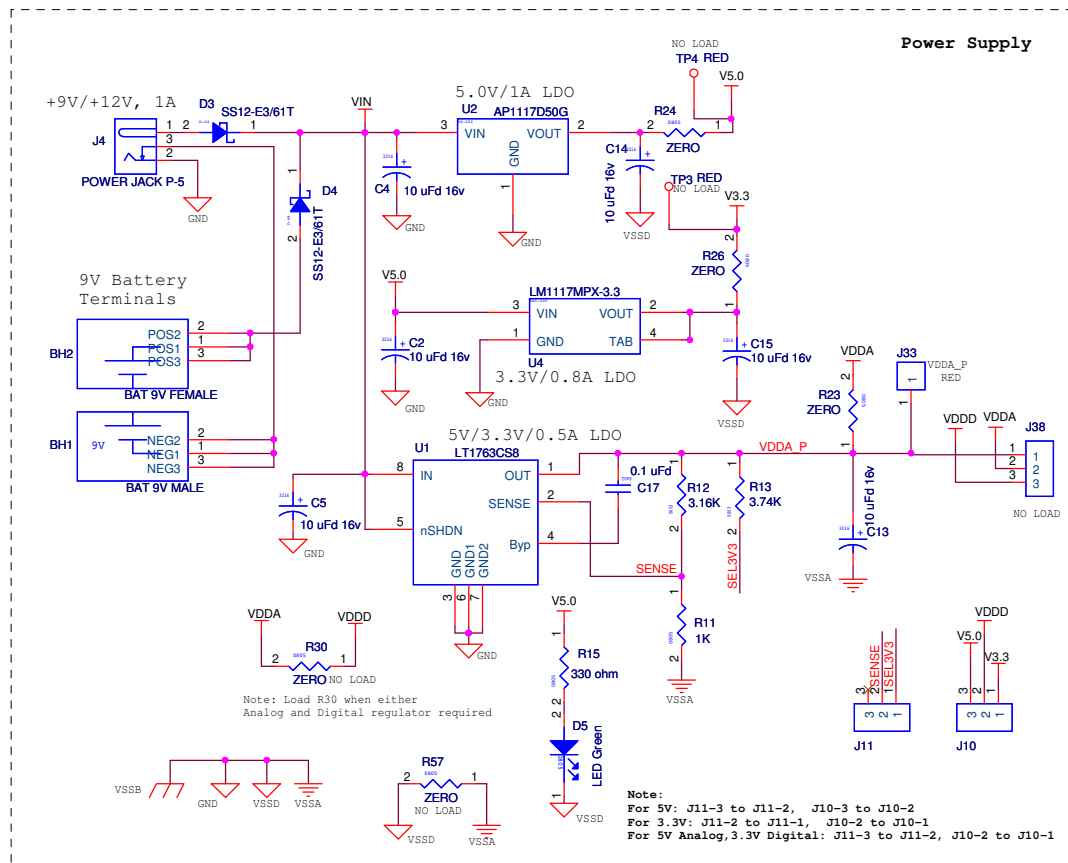

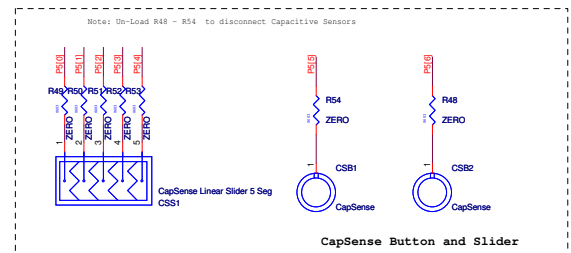
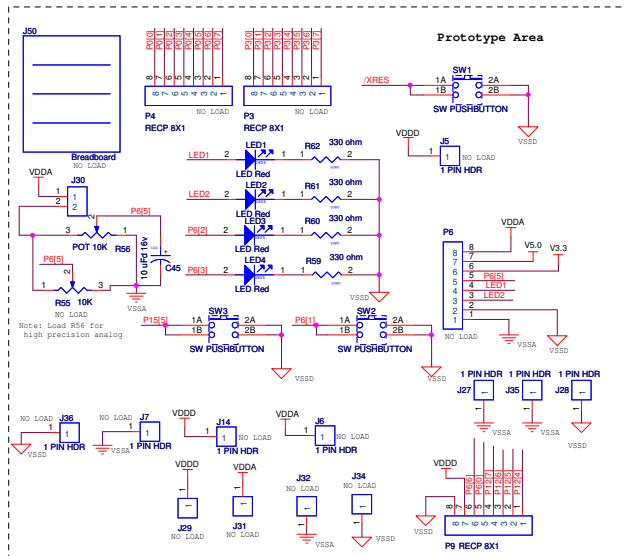
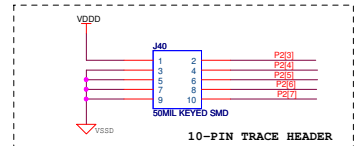
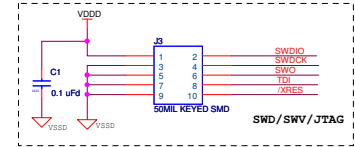
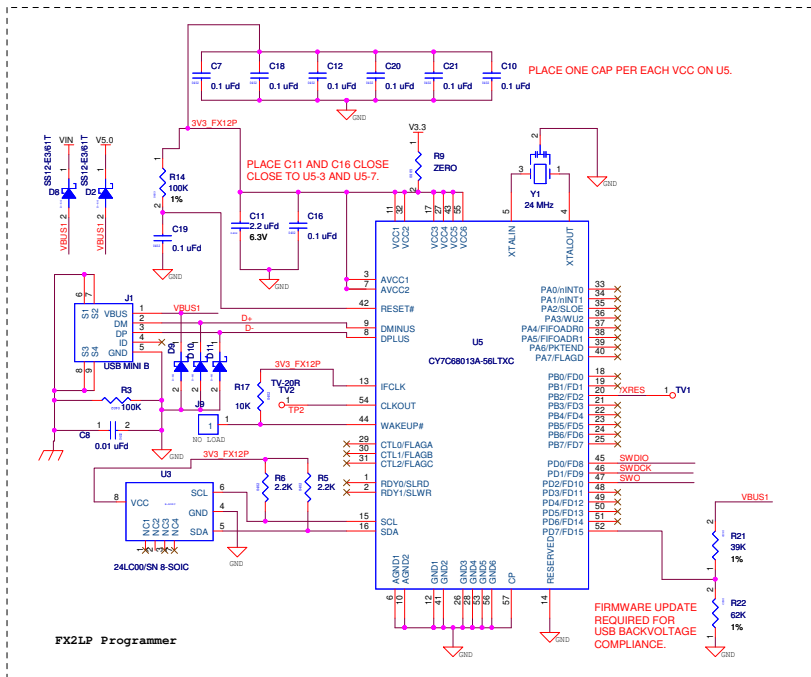

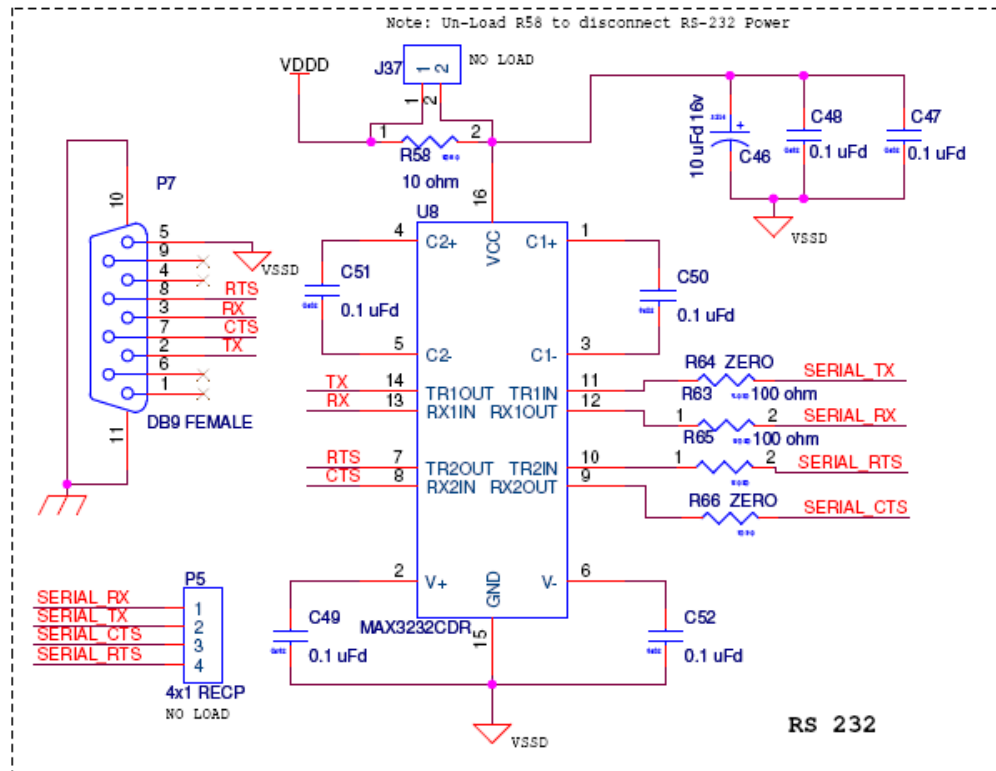
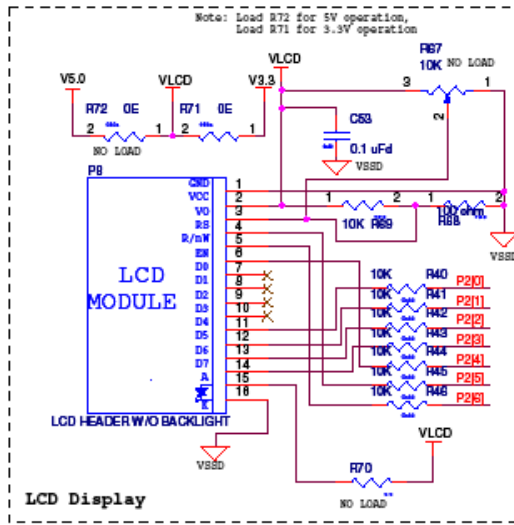
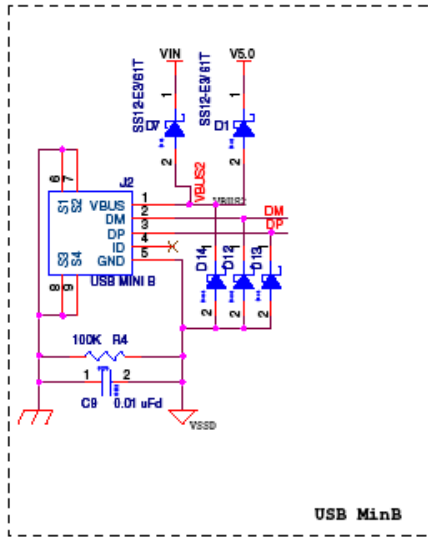

A.2 Board Layout

A.2.1 PDC-09356 Top

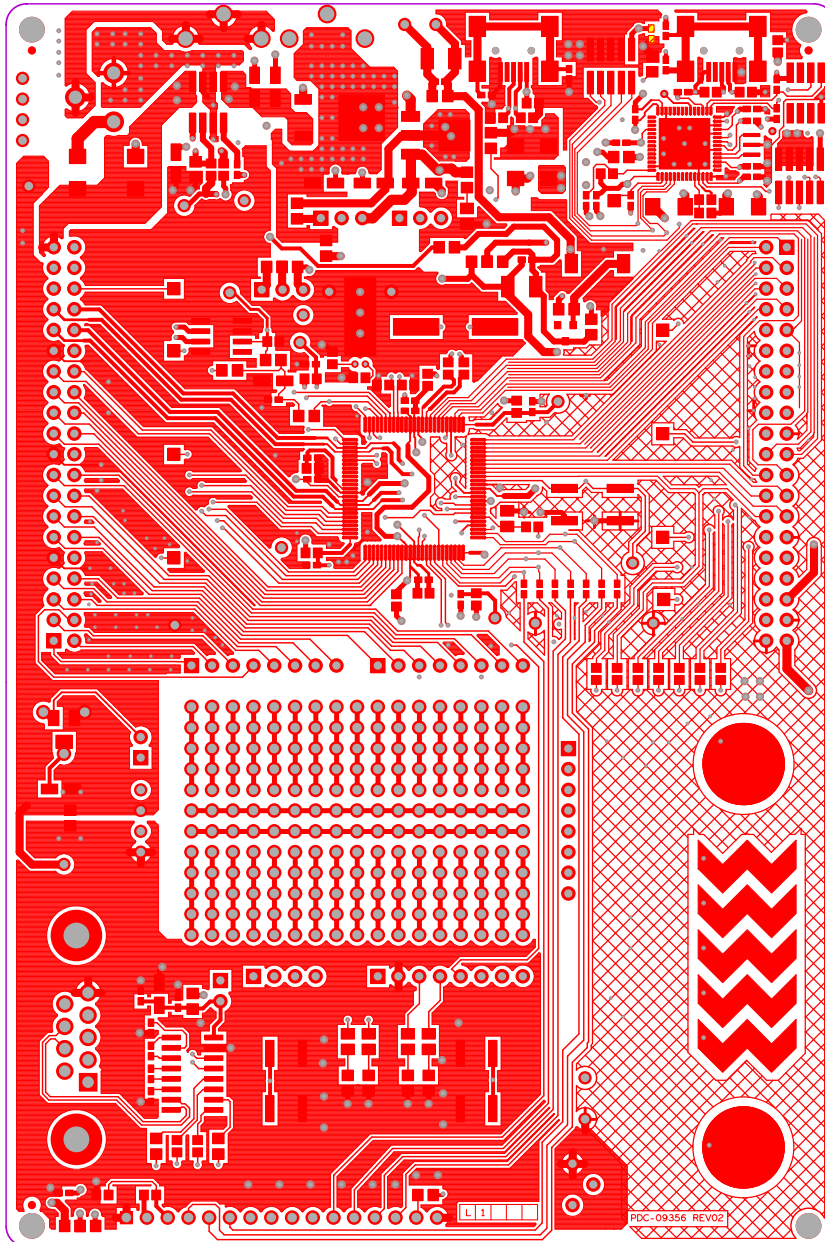

A.2.2 PDC-09356 Power

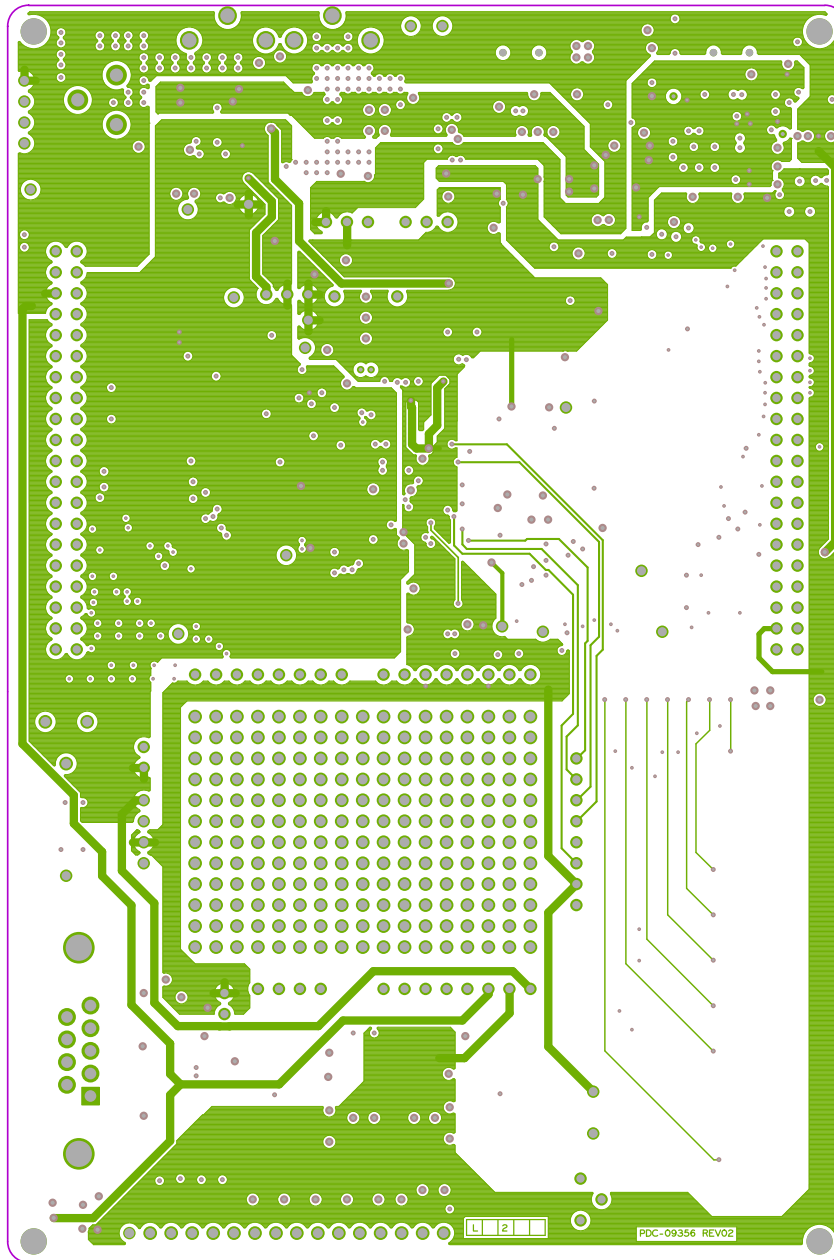

A.2.3 PDC-09356 Ground

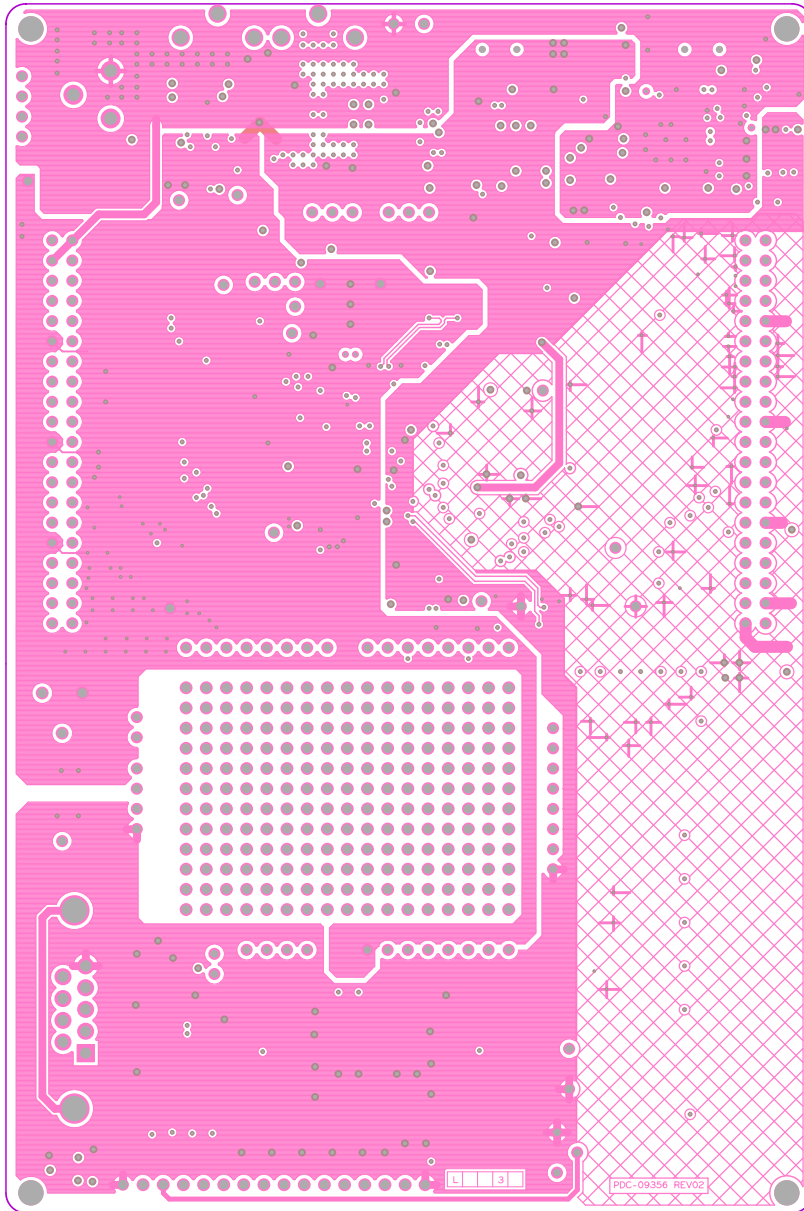

A.2.4 PDC-09356 Bottom

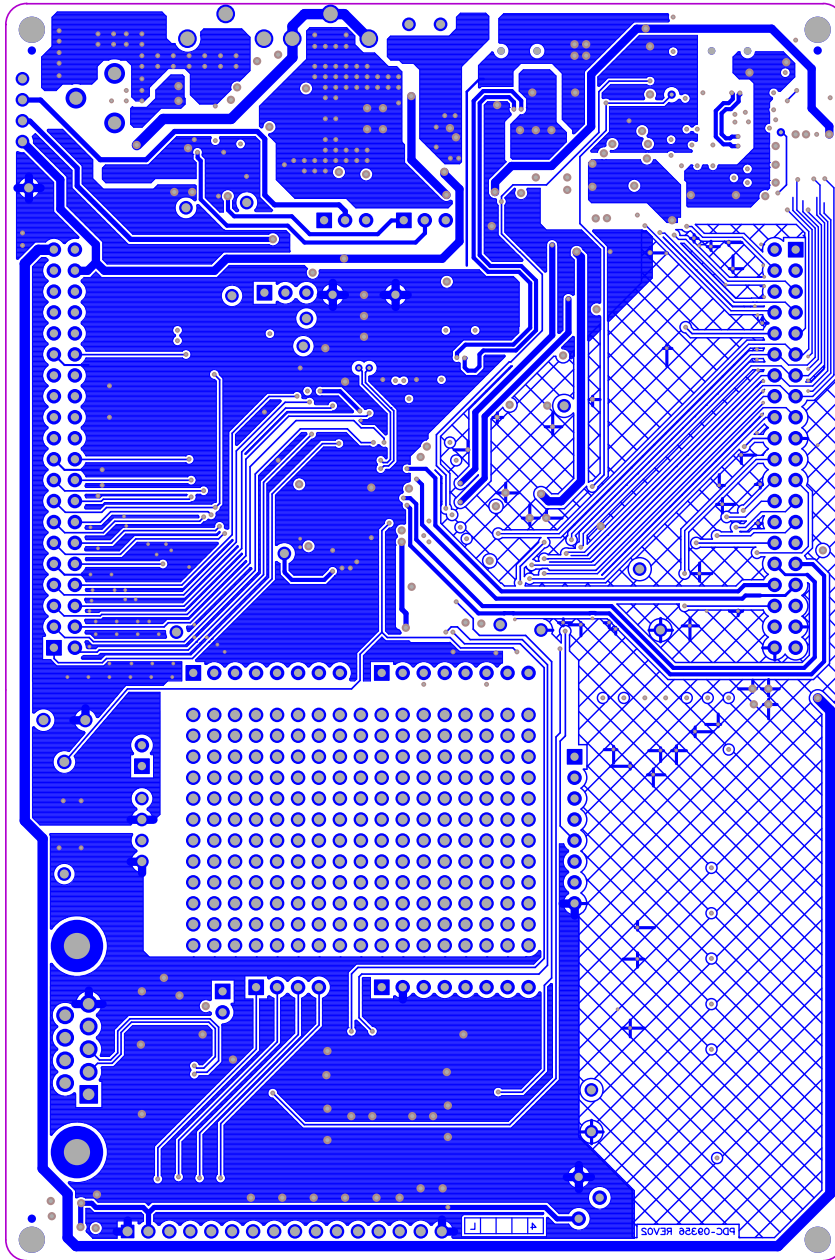

A.3 BOM

Item	Qty	Reference	Value	Description	Manufacturer	Mfr Part Number
				PCB	Cypress	PDC-09356
1	1	BH1	BAT 9V MALE	BATTERY HOLDER 9V Male PC MT	Keystone Electronics	593
2	1	BH2	BAT 9V FEMALE	BATTERY HOLDER 9V Female PC MT	Keystone Electronics	594
3	9	C2,C4,C5,C13,C14,C15,C28,C45,C46	10 uFd 16v	CAP 10UF 16V TANTALUM 10% 3216	AVX	TAJA106K016R
4	2	C6,C22	22 uFd	CAP CER 22UF 10V 10% X5R 1210	Kemet	C1210C226K8PACTU
5	29	C7,C10,C12,C16,C17,C18,C19,C20,C21,C26,C32,C33,C34,C35,C36,C38,C40,C41,C43,C47,C48,C49,C50,C51,C52,C53,C1,C3,C23	0.1 uFd	CAP .1UF 16V CERAMIC Y5V 0402	Panasonic - ECG	ECJ-0EF1C104Z
6	2	C8,C9	0.01 uFd	CAP 10000PF 16V CERAMIC 0402 SMD	Panasonic - ECG	ECJ-0EB1C103K
7	1	C11	2.2 uFd	CAP CER 2.2UF 6.3V 20% X5R 0402	Panasonic - ECG	ECJ-0EB0J225M
8	4	C29,C37,C42,C44	1.0 uFd	CAP CERAMIC 1.0UF 25V X5R 0603 10%	Taiyo Yuden	TMK107BJ105KA-T
9	2	C25,C27	22pF	CAP, CER, 22 pF, 50V, 5%, COG, 0603, SMD	Panasonic - ECG	ECJ-0EC1H220J
10	1	C39	2200 pFd	SMD/SMT 0805 2200pF 50volts COG 5%	Murata	GRM2165C1H222JA01D
11	6	D1,D2,D3,D4,D7,D8	SS12-E3/61T	DIODE SCHOTTKY 20V 1A SMA	Vishay/General Semiconductor	SS12-E3/61T
12	1	D5	LED Green	LED GREEN CLEAR 0805 SMD	Chicago Miniature	CMD17-21VGC/TR8
13	1	D6	ZHCS	DIODE SCHOTTKY 40V 1.0A SOT23-3	Zetex	ZHCS1000TA
14	2	J1,J2	USB MINI B	CONN USB MINI AB SMT RIGHT ANGLE	TYCO	1734035-2
15	2	J3,J40	50MIL KEYED SMD	CONN HEADER 10 PIN 50MIL KEYED SMD	Samtec	FTSH-105-01-L-DV-K
16	1	J4	POWER JACK P-5	CONN JACK POWER 2.1mm PCB RA	CUI	PJ-102A
17	5	TP1,J26,J27,J35,J28	BLACK TEST POINT	TEST POINT PC MINI .040"D Black	Keystone Electronics	5001
19	4	LED1,LED2,LED3,LED4	LED Red	LED RED CLEAR 0805 SMD	Rohm Semiconductor	SML-210LTT86
20	1	L1	22 uH	INDUCTOR SHIELD PWR 22UH 7032	TDK Corporation	SLF7032T-220MR96-2-PF
21	2	P1,P2	20x2 RECP RA	CONN FEMALE 40POS DL .100 R/A GOLD	Sullins Electronics Corp.	PPPC202LJBN-RC
22	1	P7	DB9 FEMALE	CONN DB9 FEMALE VERT PRESSFIT SLD	Norcomp Inc.	191-009-223R001
23	1	P8	LCD HEADER W/O BACKLIGHT	CONN RECEPT 16POS .100 VERT AU	Tyco Electronics	1-534237-4
24	2	R3,R4	100K	RES 100K OHM 1/16W 5% 0402 SMD	Panasonic - ECG	ERJ-2GEJ104X

Item	Qty	Reference	Value	Description	Manufacturer	Mfr Part Number
25	6	R9,R23,R24,R26,R27,R71	ZERO	RES 0.0 OHM 1/10W 5% 0805 SMD	Panasonic-ECG	ERJ-6GEY0R00V
26	2	R5,R6	2.2K	RES 2.2K OHM 1/16W 5% 0402 SMD	Panasonic - ECG	ERJ-2GEJ222X
27	1	R11	1K	RES 1.0K OHM 1/8W 5% 0805 SMD	Panasonic - ECG	ERJ-6GEYJ102V
28	1	R12	3.16K	RES 3.16K OHM 1/10W .5% 0603 SMD	Yageo	RT0603DRD073K16L
29	1	R13	3.74K	RES 3.74K OHM 1/10W 1% 0603 SMD	Panasonic - ECG	ERJ-3EKF3741V
30	1	R14	100K	RES 100K OHM 1/10W 1% 0603 SMD	Yageo	RC0603FR-07100KL
31	5	R15,R59,R60,R61,R62	330 ohm	RES 330 OHM 1/10W 5% 0805 SMD	Panasonic - ECG	ERJ-6GEYJ331V
32	8	R17,R40,R41,R42,R43,R44,R45,R46	10K	RES 10K OHM 1/16W 5% 0402 SMD	Stackpole Electronics Inc	RMCF 1/16S 10K 5% R
33	13	R35,R36,R39,R47,R48,R49,R50,R51,R52,R53,R54,R64,R66	ZERO	RES ZERO OHM 1/16W 5% 0603 SMD	Panasonic - ECG	ERJ-3GEY0R00V
34	2	R32,R33	22E	RES 22 OHM 1/16W 1% 0603 SMD	Panasonic - ECG	ERJ-3EKF22R0V
35	2	R63,R65	100 ohm	RES 100 OHM 1/8W 5% 0805 SMD	Rohm	MCR10EZHZJ101
36	1	R56	POT 10K	POT 10K OHM 9MM SQ PLASTIC	Bourns Inc.	3310Y-001-103L
37	1	R58	10E	RES 10 OHM 1/8W 5% 0805 SMD	Stackpole Electronics Inc	RMCF 1/10 10 5% R
38	1	R68	100 ohm	RES 100 OHM 1/16W 5% 0603 SMD	Panasonic - ECG	ERJ-3GEYJ101V
39	1	R69	10K	RES 10K OHM 1/16W 5% 0603 SMD	Panasonic - ECG	ERJ-3GEYJ103V
40	3	SW1,SW2,SW3	SW PUSHBUTTON	LT SWITCH 6MM 160GF H=2.5MM SMD	Panasonic - ECG	EVQ-Q2P02W
41	1	U1	LT1763CS8	IC LDO REG LOW NOISE ADJ 8-SOIC	Linear Technology	LT1763CS8#PBF
42	1	U2	AP1117D50G	IC REG LDO 1.0A 5.0V TO-252	Diodes Inc	AP1117D50G-13
43	1	U3	24LC00/SN	IC EEPROM 128BIT 400KHZ 8SOIC	Microchip Technology	24LC00/SN
44	1	U4	LM1117MPX-3.3	IC REG 3.3V 800MA LDO SOT-223	National Semiconductor	LM1117IMP-3.3/NOPB
45	1	U5	CY7C68013A-56LTXC	IC, FX2 HIGH-SPEED USB PERIPHERAL CONTROLLER QFN56	Cypress Semiconductor	CY7C68013A-56LTXC
46	1	U7	CY8C5588AXI-060 TQFP100	PSoC5 Mixed-Signal Array	Cypress Semiconductor	CY8C5588AXI-060
47	1	U8	MAX3232CDR	IC 3-5.5V LINE DRVR/RCVR 16-SOIC	Texas Instruments	MAX3232IDR
48	1	Y1	24 MHz	RESONATOR, 24.000MHZ, WITH CAPS, SMD	Murata	CSTCE24M0XK2010-R0
49	1	Y2	32.768KHz XTAL	CRYSTAL 32.768 KHZ CYL 12.5PF CFS308	Citizen America Corporation	CFS308-32.768KDZF-UB
50	3	J8,J33, TP2	RED TEST POINT	TEST POINT PC MINI .040"D RED	Keystone Electronics	5000

Item	Qty	Reference	Value	Description	Manufacturer	Mfr Part Number
51	1	R38	2.2K	RES 2.2KOHM 1/16W 2700PPM 5%0603	Panasonic - ECG	ERA-V27J222V
52	2	J10,J11	3p_jumper	CONN HEADER VERT SGL 3POS GOLD	3M	961103-6404-AR
53	1	J30	2p_jumper	CONN HEADER VERT SGL 2POS GOLD	3M	961102-6404-AR
54	1	NA	3.3V LCD Module 16POS w/16 pin header installed	3.3V LCD Module 16POS w/16 pin header installed	Lumex	LCM-S01602DTR/A-3
55	1	NA	16 pin header	CONN HEADER VERT SGL 16POS GOLD	3M	961116-6404-AR
56	6	D9, D10, D11, D12, D13, D14	ESD diode	SUPPRESSOR ESD 5VDC 0603 SMD	Bourns Inc.	CG0603MLC-05LE
57	1	R21	39K	RES 39.0K OHM 1/10W 1% 0603 SMD	Rohm Semiconductor	MCR03EZPF3902
58	1	R22	62K	RES 62.0K OHM 1/10W 1% 0603 SMD	Rohm Semiconductor	MCR03EZPF6202
No Load Components						
59	1	C24	1.0 uFd	CAP CERAMIC 1.0UF 25V X5R 0603 10%	Taiyo Yuden	TMK107BJ105KA-T
60	13	J5,J6,J12,J14,J29,J31 ,J18,J22,J25,TP3,TP4, J16,J39	RED	TEST POINT PC MINI .040"D RED	Keystone Electronics	5000
61	4	J7,J32,J34,J36	BLACK	TEST POINT PC MINI .040"D Black	Keystone Electronics	5001
62	1	TP5	WHITE	TEST POINT PC MINI .040"D WHITE	Keystone Electronics	5002
63	1	J50	Breadboard	BREADBOARD 17x5x2	3M	923273-I
64	4	P3,P4,P6,P9	RECP 8X1	CONN RECT 8POS .100 VERT	3M	929850-01-08-RA
65	1	R67	10K	POT 10K OHM 1/4" SQ CERM SL ST	Bourns Inc.	3362P-1-103LF
66	10	R30,R34,R57,R72,R2 5,R31,R70,R37,R29, R73	ZERO	RES 0.0 OHM 1/10W 5% 0805 SMD	Panasonic-ECG	ERJ-6GEY0R00V
67	1	R55	10K	TRIMPOT 10K OHM 4MM TOP ADJ SMD	Bourns Inc.	3214W-1-103E
68	2	R1,R28	ZERO	RES ZERO OHM 1/10W 5% 0603 SMD	Panasonic - ECG	ERJ-3GEY0R00V
69	1	U6	LM4140	IC REF PREC VOLT MICROPWR 8-SOIC	National Semiconductor	LM4140ACM-1.0/NOPB
70	1	R8	1.5K	RES 1.5KOHM 1/10W 1500PPM 5%0805	Panasonic - ECG	ERA-S15J152V
71	1	R2	3K	RES 1/10W 3K OHM 0.1% 0805	Stackpole Electronics Inc	RNC 20 T9 3K 0.1% R
72	1	P5	4x1 RECP	CONN RECEPT 4POS .100 VERT GOLD	3M	929850-01-04-RA
73	1	J38	3p_jumper	CONN HEADER VERT SGL 3POS GOLD	3M	961103-6404-AR
74	1	J37	2p_jumper	CONN HEADER VERT SGL 2POS GOLD	3M	961102-6404-AR
75	1	Y3	24 MHz Crystal	CRYSTAL 24.000MHZ 20PF SMD	ECS Inc	ECS-240-20-5PX-TR
76	2	C30,C31	22 pF	CAP, CER, 22 pF, 50V, 5%, COG, 0603, SMD	Panasonic - ECG	ECJ-0EC1H220J

Item	Qty	Reference	Value	Description	Manufacturer	Mfr Part Number
77	2	CSB1,CSB2	CapSense	CapSense Button	Cypress	
78	1	CSS1	CapSense Linear Slider 5 Seg	CapSense Slider	Cypress	
79	9	J9,J13,J15,J17,J19,J20,J21,J23,J24	PADS	PADS		
80	2	TV1,TV2	PADS	PADS		
Install On Bottom of PCB As Close To Corners As Possible						
81	5			BUMPER CLEAR .500X.23" SQUARE	Richco Plastic Co	RBS-3R
Special Jumper Installation Instructions						
82	1	J30	Install jumper across pins 1 and 2	Rectangular Connectors MINI JUMPER GF 13.5 CLOSE TYPE BLACK	Kobiconn	151-8030-E
83	2	J10, J11	Install jumper across pins 1 and 2	Rectangular Connectors MINI JUMPER GF 13.5 CLOSE TYPE BLACK	Kobiconn	151-8030-E

