

C200H-TV□□□

Heat/Cool

Temperature Control Unit

Operation Manual

Cat. No. W240-E3-1

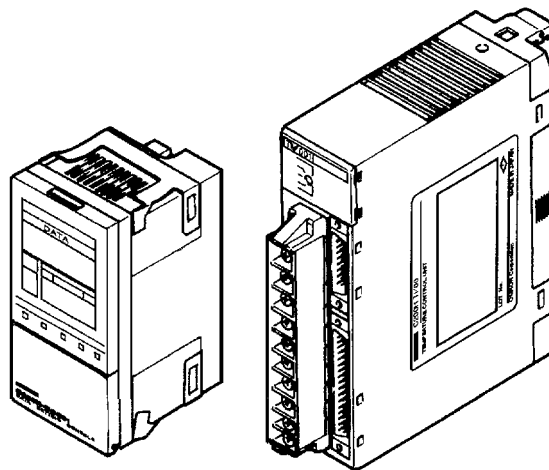

Notice:

OMRON products are manufactured for use according to proper procedures by a qualified operator and only for the purposes described in this manual.

The following conventions are used to indicate and classify precautions in this manual. Always heed the information provided with them. Failure to heed precautions can result in injury to people or damage to the product.

DANGER! Indicates information that, if not heeded, is likely to result in loss of life or serious injury.

WARNING Indicates information that, if not heeded, could possibly result in loss of life or serious injury.

Caution Indicates information that, if not heeded, could result in relative serious or minor injury, damage to the product, or faulty operation.

OMRON Product References

All OMRON products are capitalized in this manual. The word "Unit" is also capitalized when it refers to an OMRON product, regardless of whether or not it appears in the proper name of the product.

The abbreviation "Ch," which appears in some displays and on some OMRON products, often means "word" and is abbreviated "Wd" in documentation in this sense.

The abbreviation "PC" means Programmable Controller and is not used as an abbreviation for anything else.

Visual Aids

The following headings appear in the left column of the manual to help you locate different types of information.

Note Indicates information of particular interest for efficient and convenient operation of the product.

1, 2, 3... 1. Indicates lists of one sort or another, such as procedures, checklists, etc.

© OMRON, 1998

All rights reserved. No part of this publication may be reproduced, stored in a retrieval system, or transmitted, in any form, or by any means, mechanical, electronic, photocopying, recording, or otherwise, without the prior written permission of OMRON.

No patent liability is assumed with respect to the use of the information contained herein. Moreover, because OMRON is constantly striving to improve its high-quality products, the information contained in this manual is subject to change without notice. Every precaution has been taken in the preparation of this manual. Nevertheless, OMRON assumes no responsibility for errors or omissions. Neither is any liability assumed for damages resulting from the use of the information contained in this publication.

TABLE OF CONTENTS

SECTION 1	
System Configuration and Features	1
1-1 Features	2
1-2 Basic System Configuration	3
SECTION 2	
Connections and Settings	5
2-1 Nomenclature	6
2-2 Switch Settings	7
2-3 Wiring	10
2-3-1 Input Wiring	10
2-3-2 Output Wiring	13
2-3-3 Data Setting Console Cables	17
SECTION 3	
Data Setting Console Operation	19
3-1 Operating Procedure	20
3-2 Data Flow	21
3-3 Nomenclature and Features	22
3-3-1 Nomenclature	22
3-3-2 Features	23
3-4 Parameter Displays and Settings	24
3-4-1 Table of Parameters	24
3-4-2 How to Display and Set Parameter Data	26
SECTION 4	
PC Memory Allocation and Programming	35
4-1 Memory Allocation	36
4-1-1 Memory Allocation Table	37
4-1-2 Memory Contents	38
4-1-3 Table of Commands	41
4-2 Data Flow	43
4-3 Programming	43
4-3-1 Example with SW2-1 in the Fixed Position	43
4-3-2 Example 1: Write with SW2-1 in the Normal Position	44
4-3-3 Example 2: Read with SW2-1 in the Normal Position	47
4-3-4 Operation Timing	50
SECTION 5	
Troubleshooting	53
Error Detection	54
A Specifications	57
B Sensor Temperature Measurement Ranges	59
C Heater Burnout Detection	61
D Parameters and Key Operations	67
Index	69
Revision History	71

About this Manual:

This manual describes the installation and operation of the C200H-TV□□□ Heat/Cool Temperature Control Unit and includes the sections described below. Also briefly described is the basic operation and installation of the C200H-DSC01 Data Setting Console.

Please read this manual carefully and be sure you understand the information provided before attempting to install and operate the Heat/Cool Temperature Control Unit and Data Setting Console.

Section 1 provides Heat/Cool Temperature Control Unit features and describes its basic system configuration.

Section 2 provides information on the connections and settings of the Heat/Cool Temperature Control Unit.

Section 3 provides the basic operating procedures of the Data Setting Console including parameter settings and displays.

Section 4 provides the C200H PC's memory allocation for the Heat/Cool Temperature Control Unit. Basic programming procedures and examples are also provided.

Section 5 provides possible errors and error remedies.

The five **Appendices** provide references dealing with specifications, sensor temperature measurement ranges, heater burnout detection, and dimensions, and a table of Data Setting Console key operations.

<p>WARNING Failure to read and understand the information provided in this manual may result in personal injury or death, damage to the product, or product failure. Please read each section in its entirety and be sure you understand the information provided in the section and related sections before attempting any of the procedures or operations given.</p>

SECTION 1

System Configuration and Features

This section provides Heat/Cool Temperature Control Unit features and describes its basic system configuration.

1-1	Features	2
1-2	Basic System Configuration	3

1-1 Features

The Heat/Cool Temperature Control Unit measures the temperature of an object with a connected temperature sensor (thermocouple or platinum resistance thermometer) and controls the temperature according to preset parameters.

Advanced PID Control

Stable temperature control is achieved using advanced PID control and an auto-tuning feature.

ON/OFF control can also be selected.

Units Available According to Type of Temperature Sensor

Two types of Temperature Control Unit are available, according to the temperature sensor used. The C200H-TV00 uses a thermocouple, and the C200H-TV10 uses a platinum resistance thermometer.

Two Heat/Cool Control Loops with a Single Unit

Two heating and cooling control loops are possible with one Unit.

Comprehensive Output Specifications

Three types of output specification versions are available: C200H-TV 1 for transistor output, C200H-TV 2 for voltage output, and C200H-TV 3 for current output.

Heater Burnout Detection

A Current Transformer (with a detection current range of 0.1 to 49.9 A and a minimum detection current difference of 2.5 A) can be connected to each of the two control loops to facilitate rapid heater burnout detection and prompt correction of problems.

Eight Banks of Data Settings

Eight data values such as set point (SP) and alarm set values can be preset in eight data banks for easy selection.

Data Input and Display

The C200H-DSC01 Data Setting Console (sold separately) is used to input data and to display process values (PV) and set values (SV).

The easy-to-read display can be panel-mounted.

User Programs Allow Reading and Writing of Data

Data can be set and retrieved by means of C200H user programs.

1-2 Basic System Configuration



Heat/Cool Temperature Control Unit:
 C200H-TV00 (for thermocouples)
 C200H-TV10 (for platinum resistance thermometers)

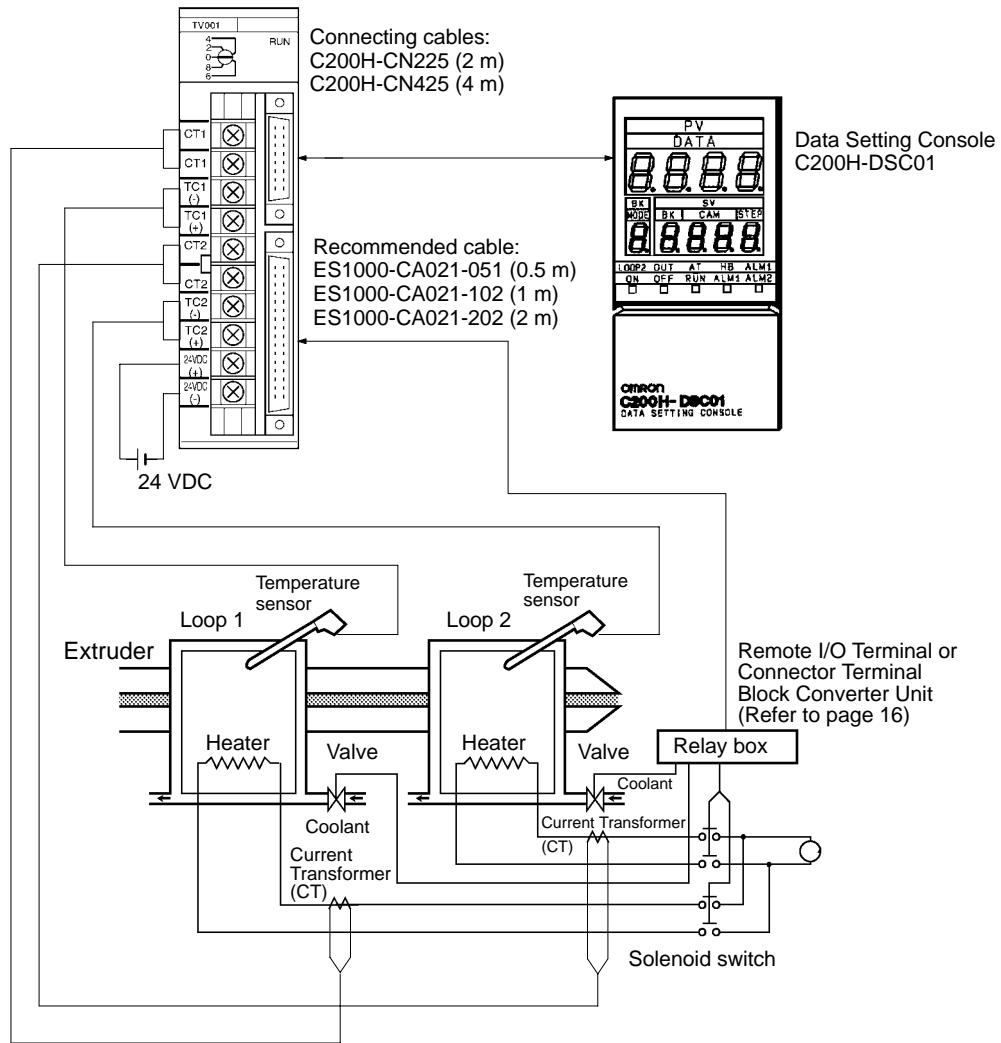

Heat/Cool Temperature Control Unit Models

Sensor	Output type		
	Transistor output	Voltage output	Current output
Thermocouple	C200H-TV001	C200H-TV002	C200H-TV003
Platinum resistance thermometer	C200H-TV101	C200H-TV102	C200H-TV103

Number of Units The Heat/Cool Temperature Control Unit belongs to the C200H Special I/O Unit group. A maximum of ten Special I/O Units (including PC Link Units) can be mounted on each of the following Racks: CPU Rack, Expansion I/O Rack, and Slave Rack.

Note Configure the Units such that the maximum current supplied for each Rack is greater than or equal to the total current consumption for the Units. Refer to the *C200H PC Operation Manuals*.

Number of Units Mountable on Slave Rack The number of Special I/O Units used with a Slave Rack is limited by data transmission considerations, as shown in the table below. The numbers in the table indicate the maximum number of Units of groups A, B, C, or D which can be used with a single Slave Rack.

A	B	C	D
High-speed Counter Units Position Control Units (NC111/112) ASCII Units ID Sensor Units Fuzzy Logic Units	High-density and Mixed I/O Units Temperature Control Units Heat/Cool Temperature Control Units PID Control Units Cam Positioner Units	Temperature Sensor Units Voice Units	Position Control Units (NC211)
4 units max.	8 units max.	6 units max.	2 units max.

Note

- When a combination of Units from groups A, B, C, and D is used, the number from each group must satisfy both the following equations:

$$3A + B + 2C + 6D \leq 12$$

$$A + B + C + D \leq 8$$
- Other Units can be added until the total number of Units reaches ten. If PC Link Units are used, the number of Units including the PC Link Units must not exceed ten.

Precautions The IR area of the C200H Special I/O Unit is allocated according to the setting of the unit number switch on the front panel, *not* the address of the slot where the unit is mounted. Refer to *4-1 Memory Allocation* for the allocation of the memory area.

Leave the two slots next to the CPU free. It is not possible to use devices connected to the CPU (such as the Programming Console) if these slots are occupied.

If the C200H Slave Rack is connected to another SYSMAC model Remote I/O Master Unit, such as the C120, C500, C1000H, or C2000H, it is not possible to use a Special I/O Unit with the C200H Slave Rack.

WARNING Always turn the C200H power off before connecting or disconnecting a Unit, terminal block, or output connector.

Caution Connect thermocouples with the appropriate compensating conductor. Wire I/O leads in separate ducts from power leads to prevent noise problems.

SECTION 2

Connections and Settings

This section provides information on the connections and settings of the Heat/Cool Temperature Control Unit.

2-1	Nomenclature	6
2-2	Switch Settings	7
2-3	Wiring	10
2-3-1	Input Wiring	10
2-3-2	Output Wiring	13
2-3-3	Data Setting Console Cables	17

2-1 Nomenclature

C200H-TV00 (For Thermocouple)

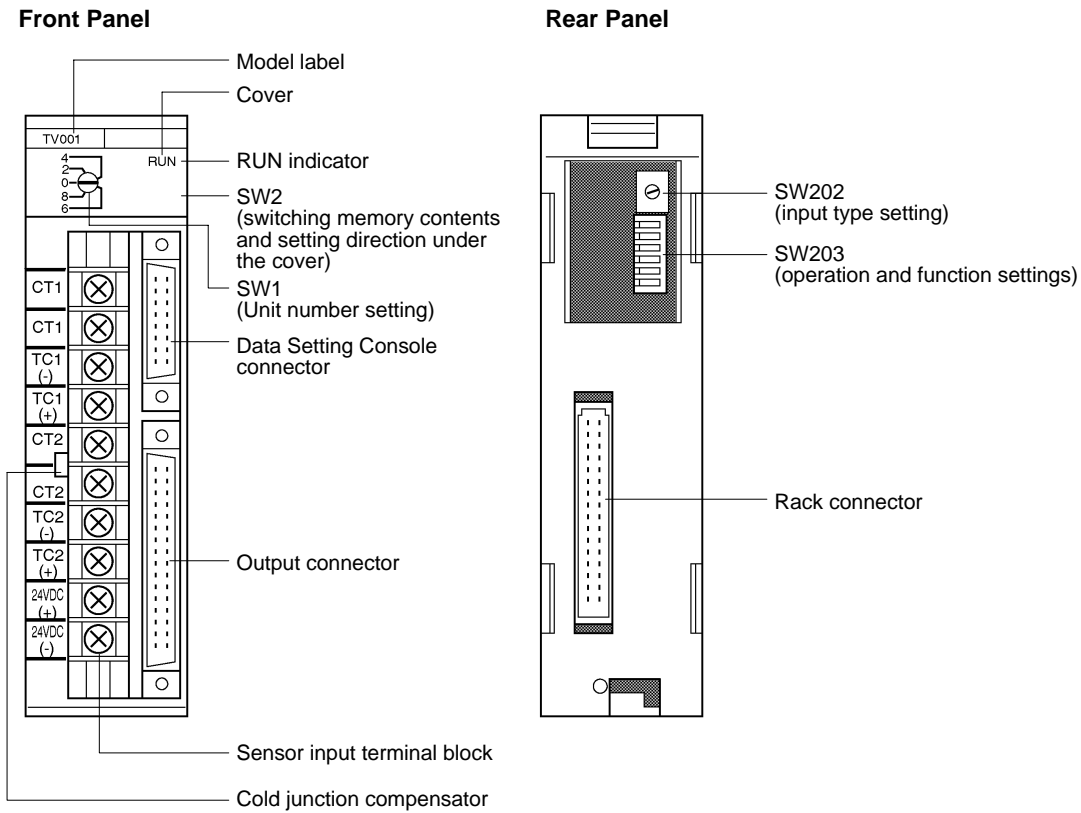

C200H-TV10 (For Platinum Resistance Thermometer)

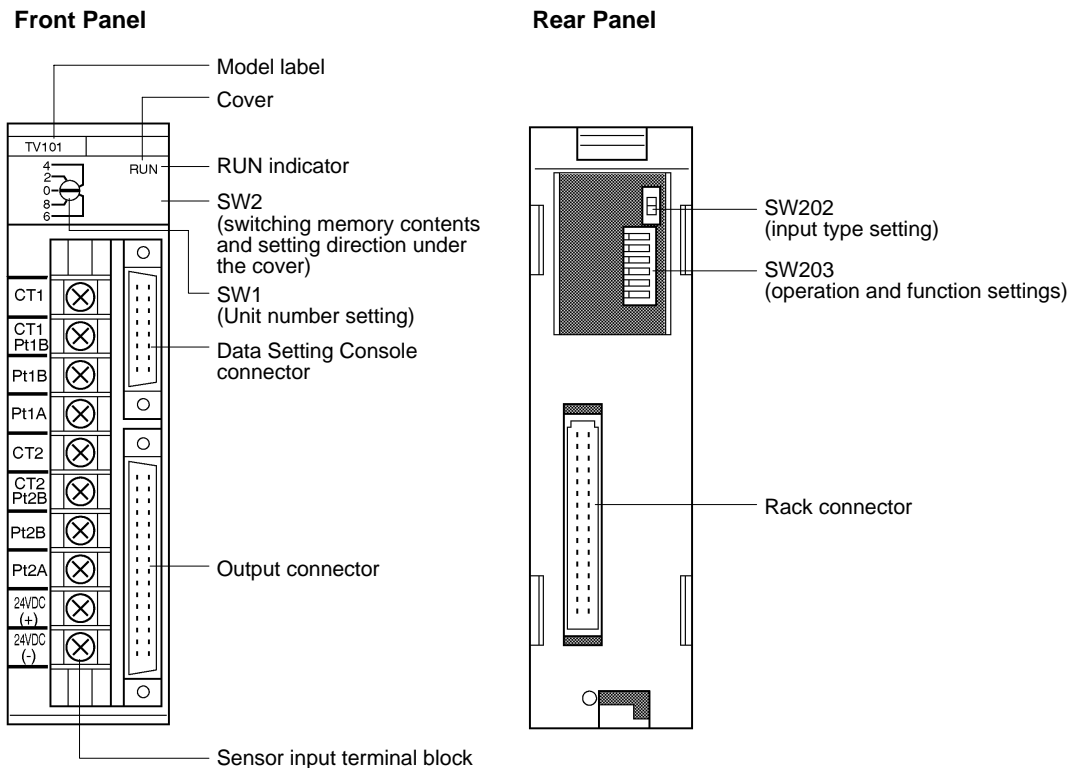

Indicators

RUN	Lit when the Heat/Cool Temperature Control Unit is operating normally. Unlit when an alarm occurs, and Unit operation stops.
------------	---

2-2 Switch Settings

The function and setting of switches are identical for all models, except SW202.

Unit Number

SW1	Unit number setting
------------	---------------------

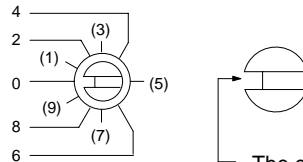

The cut-out indicates the selected position. Negative numbers are not indicated. Turn the switch with a flat-blade screwdriver. Turn the switch until it clicks in position. Do not leave the switch between two settings.

The addresses are allocated as shown in the following table according to the Unit number setting.

Unit no. setting	Allocated address
0	Wd 100 to 109
1	Wd 110 to 119
2	Wd 120 to 129
3	Wd 130 to 139
4	Wd 140 to 149
5	Wd 150 to 159
6	Wd 160 to 169
7	Wd 170 to 179
8	Wd 180 to 189
9	Wd 190 to 199

The switch is factory-set to 0.

Note If the Unit number is set to an existing Unit number, an alarm occurs and the C200H does not operate.

Turn the C200H power off before setting the Unit number. If the setting is changed with the power on, the new setting is not valid until the power is turned off and back on again.

Switching Memory Contents and Setting Direction

SW2	Switching memory contents and setting direction
------------	---

Remove the cover and set the switch with the tip of a ballpoint pen or a similar object.

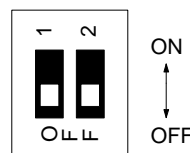

Switch no.	Pin 1	Pin 2
Function	Switching memory contents	Setting direction
ON	Normal	C200H PC
OFF	Fixed	Data Setting Console

The new setting is valid immediately after the switch setting is changed.

Removing and Attaching the Cover

Removing the Cover

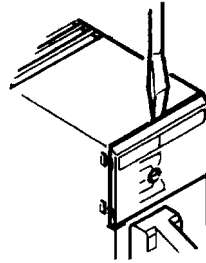

Insert a small flat-blade screwdriver between the case and the cover at the top of the Unit and lever off the cover.

Attaching the Cover

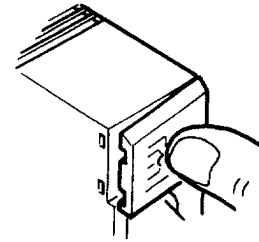

Place the right edge of the cover against the case and press into position.

Switching Memory Contents The methods for designating parameters differ as shown below.

Normal	Parameters can be designated as required using commands. (Refer to 4-1 Memory Allocation).
Fixed	Parameters are allocated in advance.

Refer to 4-1 Memory Allocation for details of the memory contents.

Setting Direction Selector Selects whether the data settings are made from the Data Setting Console or from the C200H PC, using a user program or Programming Console.

Executed Bank Number

The setting of the executed bank number is made from the C200H PC, regardless of the ON/OFF setting of this switch.

Input Type

SW202	Input type setting
-------	--------------------

C200H-TV00

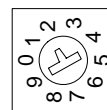

Setting	0	1	2	3	4	5	6	7	8	9
Sensor type	R	S	K	J	T	E	B	N	L	U

The switch is factory-set to 2.

The selected position is shown by the arrow. Turn the switch with a small flat-blade screwdriver.

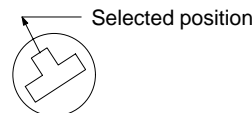

C200H-TV10

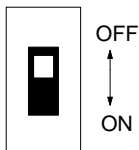

Setting	Input type
OFF	JPt 100
ON	Pt 100

The switch is factory-set to OFF.

See Appendix B Sensor Temperature Measurement Range for the measurable temperature range.

Operation and Function Setting

SW203	Operation and Function Setting
-------	--------------------------------



OFF ↔ ON

Pin no.	Function	OFF	ON
6	Loop 1 Cooling control output	Pulses	Current output
5	SP write mode	Write to EEPROM and RAM	Write to RAM only
4	Loop 2	Enabled	Disabled or not used
3	Display unit	°C	°F
2	Not used.	---	---
1	Control method	PID control	ON/OFF control

The switch is factory-set to OFF.

Loop 1 Cooling Control Output

This setting is valid when the heating output type is “current,” and input loop 2 is not used (i.e., when pin no. 4 of switch 203 is ON).

SP Write Mode

This setting selects the SP storage memory. Set it to ON if the writing is to be frequently changed.

Loop 2

Set to “enabled” to use input loop 2, or to “disabled” to use only input loop 1. It is not possible to use only input loop 2.

Note Always set this switch to the ON (disabled) position when input loop 2 is not used. A sensor error occurs if this switch is set to the OFF (enabled) position when no temperature sensor is connected to loop 2.

Display Unit

Selects whether displays and set values are shown on the Data Setting Console in Celsius or in Fahrenheit.

Control Method

Selects the method of control.

2-3 Wiring

2-3-1 Input Wiring

C200H-TV00 Thermocouple

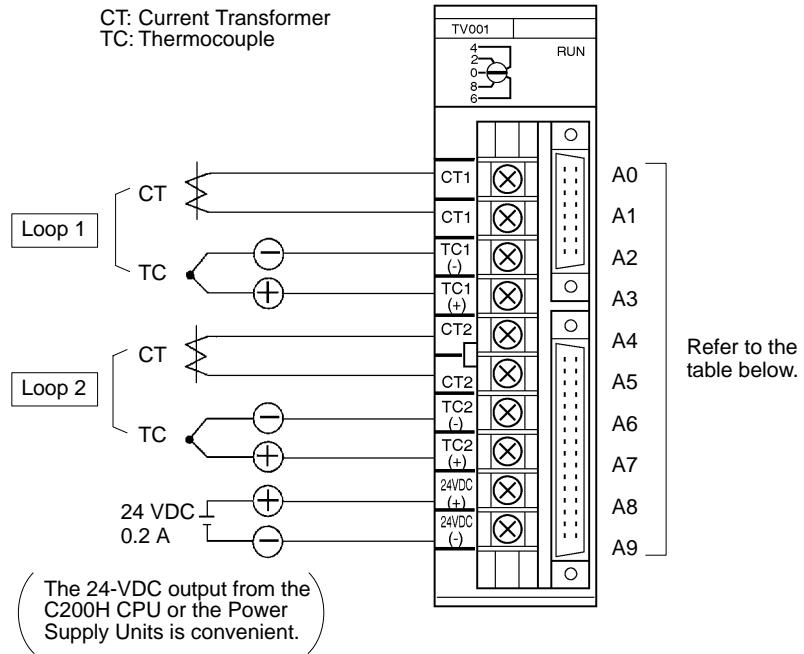

Terminal no.	Terminal name	
A0	CT	Loop 1
A1	CT	
A2	TC (-)	
A3	TC (+)	
A4	CT	Loop 2
A5	CT	
A6	TC (-)	
A7	TC (+)	
A8	24 VDC	
A9	GND	

C200H-TV10 Platinum Resistance Thermometer

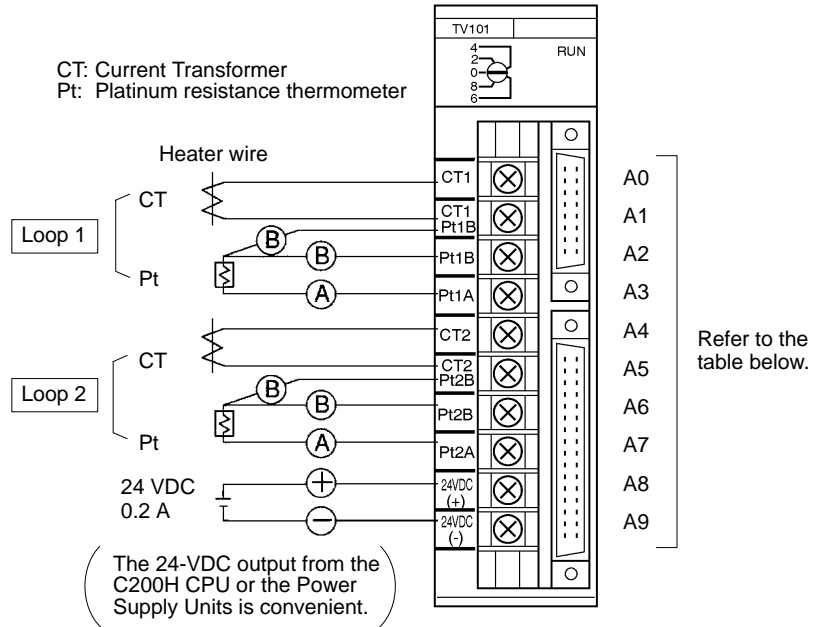

Terminal no.	Terminal name	
A0	CT	Loop 1
A1	CT/Pt (B)	
A2	Pt (B)	
A3	Pt (A)	
A4	CT	Loop 2
A5	CT/Pt (B)	
A6	Pt (B)	
A7	Pt (A)	
A8	24 VDC	
A9	GND	

Screw down Pt(B) and CT together at terminals A1 and A5.

Input Wiring Precautions

1, 2, 3...

- Set the type of temperature sensor to thermocouple or platinum resistance thermometer with SW202 on the rear of the Unit.
The Unit will not operate correctly if the switch setting does not match the type of temperature sensor connected.
Do not connect different types of temperature sensors to Loop 1 and Loop 2.
- If no input lead is connected to Loop 2, turn SW203-4 on the rear of the Unit ON to disable Loop 2. A sensor error occurs if this switch is set to the OFF (enabled) position when no temperature sensor is connected to Loop 2.
- Be sure to connect (+) and (-), and (A) and (B) correctly.
- Wire I/O leads in separate ducts from power leads to prevent noise problems.
- A voltage of 24 VDC is used for the voltage output, current output and Data Setting Console power supply.
- The terminal block is removable. Make sure that it is attached correctly after the input wiring connections are completed.

Terminal Block Connections

Crimp terminals are recommended for the wiring. Take care not to overtighten the terminal screws. Tightening torque must not exceed 78 N·cm (8 kg·cm).

Crimp Terminals

The screws on the terminal block are M3.5 self-rising terminal screws. Use the following types of M3.5 crimp terminals.

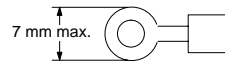

Soldered Lead

Strip insulation from 7 to 10 mm at the end of the wire and carefully solder the lead.

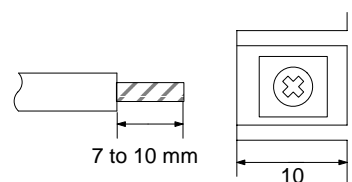

Compensating Conductors

Connect a thermocouple with the appropriate compensating conductor from the table below.

Type of thermocouple		Compensating conductor		Classification by application and tolerance	Constituent materials	
Symbol	Previous symbol (reference)	Symbol	Previous symbol (reference)		+ conductor	- conductor
B	---	BX-G	---	General-purpose, standard class	Copper	Copper
R	---	RX-G, SX-G	---			Alloy with copper or nickel as major constituent
S	---	RX-H, SX-H	---	Heat-resistant, standard class		
K	CA	KX-G	WCA-G	General-purpose, standard class	Alloy with nickel or chrome as major constituent	Alloy with nickel as major constituent
		KX-GS	WCA-GS			
		KX-H	WCA-H	Heat-resistant, standard class		
		KX-HS	WCA-HS	Heat-resistant, precision class		
		WX-G	WCA-G	General-purpose, standard class	Iron	Alloy with copper or nickel as major constituent
		WX-H	WCA-H	Heat-resistant, standard class		
		VX-G	WCA-G	General-purpose, standard class	Copper	
E	CRC	EX-G	WCRC-G	General-purpose, standard class	Alloy with nickel or chrome as major constituent	
		EX-H	WCRC-H	Heat-resistant, standard class		
J	IC	JX-G	WIC-G	General-purpose, standard class	Iron	
		JX-H	WIC-H	Heat-resistant, standard class		

Type of thermocouple		Compensating conductor		Classification by application and tolerance	Constituent materials	
Symbol	Previous symbol (reference)	Symbol	Previous symbol (reference)		+ conductor	- conductor
T	CC	TX-G	WCC-G	General-purpose, standard class	Copper	Alloy with copper or nickel as major constituent
		TX-GS	---	General-purpose, precision class		
		TX-H	WCC-H	Heat-resistant, standard class		
		TX-HS	---	Heat-resistant, precision class		

Wiring Platinum Resistance Thermometers

Connect a platinum resistance thermometer with copper wire. All three leads should have the same thickness and the same length to give them identical resistances. Do not branch the two (B) leads near the terminal block as this increases measurement errors.

Current Transformer

Use an E54-CT1 or E54-CT3 Current Transformer (CT). Refer to *Appendix C Heater Burnout Detection* for details of the Current Transformer specifications and installation dimensions.

2-3-2 Output Wiring

Connection Diagrams

C200H-TV 01 Transistor Output

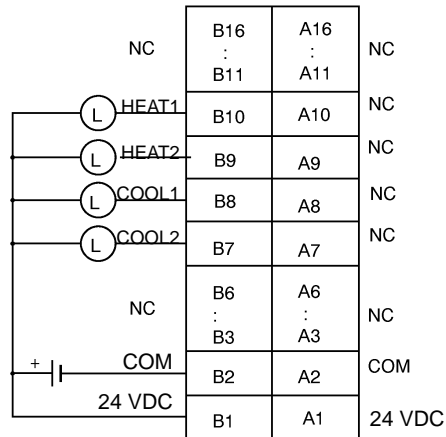

NC: Not connected

The pairs of terminals B2 to A2 and B1 to A1 are shorted internally. Always supply power to the 24-VDC terminal (B1) as this drives the internal circuits.

C200H-TV 02/TV 03 Voltage/Current Output

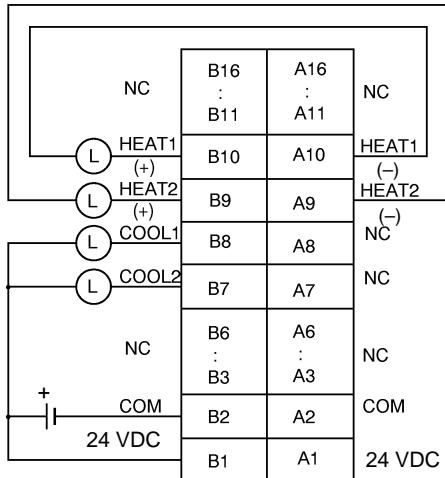

Circuit Diagrams

C200H-TV 01 Transistor Output

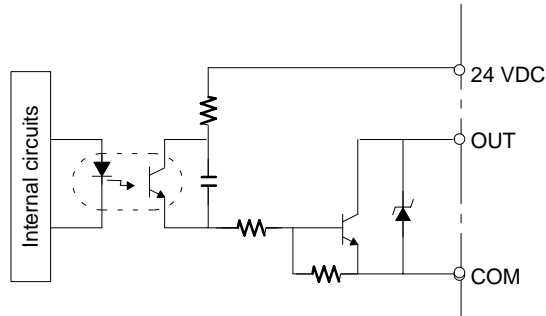

C200H-TV 02 Voltage Output

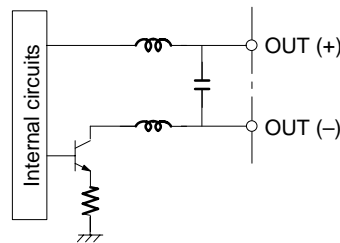

C200H-TV 03 Current Output

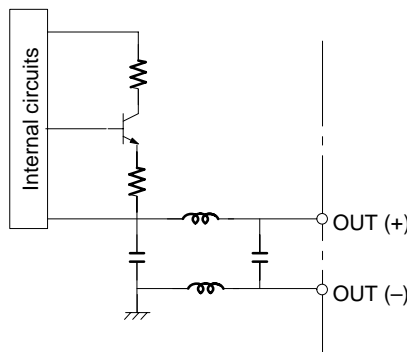

Applicable Connectors

The following connector set manufactured by Fujitsu is included with the Unit:
 FCN-361J032-AU (soldering connector)
 FCN-360C032-B (cover)

Connector Wiring Precautions

After soldering the lead to each pin, insulate with heat-shrink tube to prevent shorting with the adjacent terminal.

Connection Precautions

Tighten the screws after inserting the connector into the Unit. Push the connector firmly into the Remote I/O Terminal or Connector Terminal Block Converter Unit until it fully locks.

Output Cable

The output cables in the table below are recommended.

Model	Cable length (L)
ES1000-CA021-051	0.5 m
ES1000-CA021-102	1 m
ES1000-CA021-202	2 m

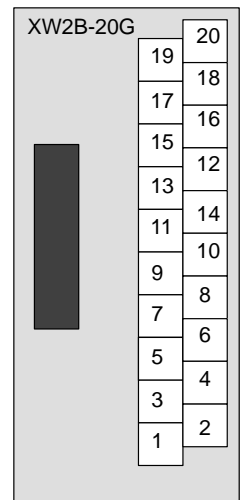
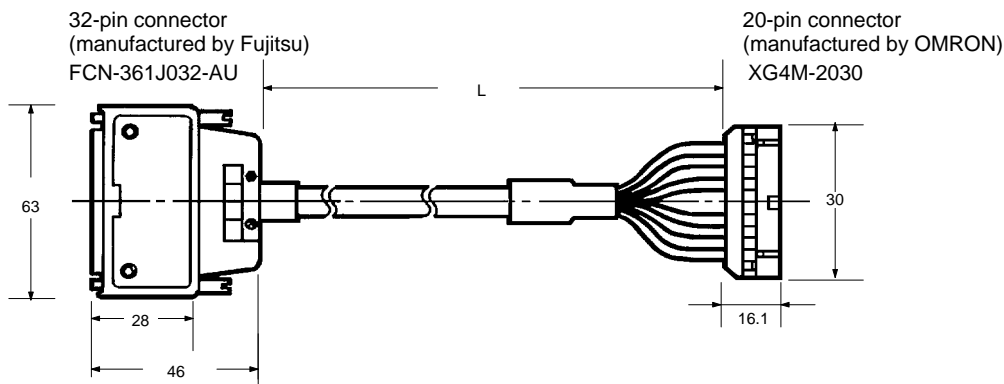

Wiring Diagrams

32-pin connector

Pin no.	Wire no.	Pin no.	Wire no.
B16		A16	
B15		A15	
B14		A14	
B13		A13	
B12		A12	
B11		A11	
B10	#1	A10	#11
B9	#2	A9	#12
B8	#3	A8	#13
B7	#4	A7	#14
B6	#5	A6	#15
B5	#6	A5	#16
B4	#7	A4	#17
B3	#8	A3	#18
B2	#9	A2	#19
B1	#10	A1	#20

20-pin connector

Pin no.	Wire no.	Pin no.	Wire no.
1	#1	11	#11
2	#2	12	#12
3	#3	13	#13
4	#4	14	#14
5	#5	15	#15
6	#6	16	#16
7	#7	17	#17
8	#8	18	#18
9	#9	19	#19
10	#10	20	#20

Pin no.	Terminal no.
1	20
2	18
3	16
4	14
5	12
6	10
7	8
8	6
9	4
10	2

Note The pin numbers of the 20-pin connector are marked for convenience. Refer to them from the Δ mark.

Pin no.	Terminal no.
11	19
12	17
13	15
14	13
15	11
16	9
17	7
18	5
19	3
20	1

Note Pins A11 through A16 and B11 through B16 are not connected.

Remote I/O Terminal

The Remote I/O Terminal in the table below is recommended for transistor output.

Model	Specification	Relays used
G7TC-OC08	Common (+)	8 x G7T-1112S (max. resistive load: 220 VAC, 2A)

Note One P7TF-OS08 I/O Terminal and two G7T-1112S Relays may be purchased separately and used.

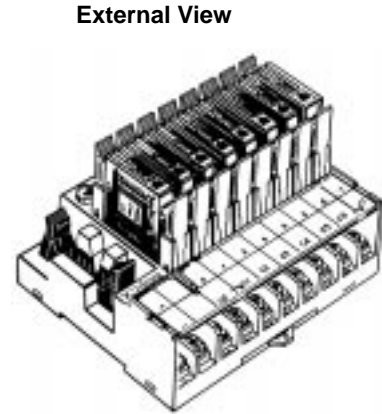
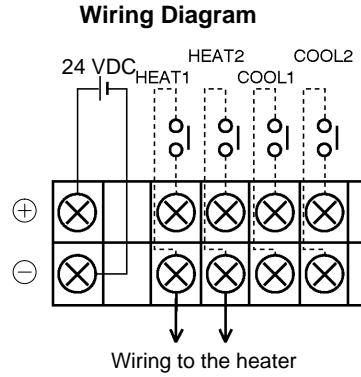

Connector Terminal Block Converter Unit

The Connector Terminal Block Converter Units in the table below are recommended for voltage output and current output type.

Model	Terminal screw size
XW2B-20G4	M 2.4
XW2B-20G5	M 3.5

External View

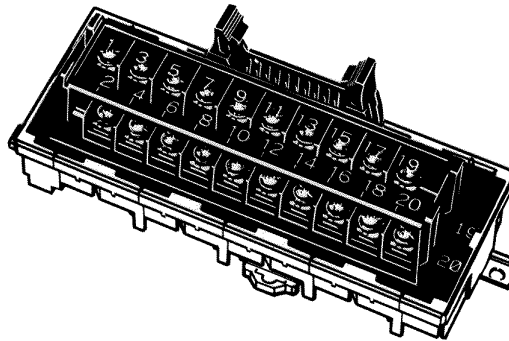

2-3-3 Data Setting Console Cables

Connecting Cable

Use the connecting cables in the table below (sold separately) to connect the Unit to the Data Setting Console.

Model	Cable length (L)
C200H-CN225	2 m
C200H-CN425	4 m

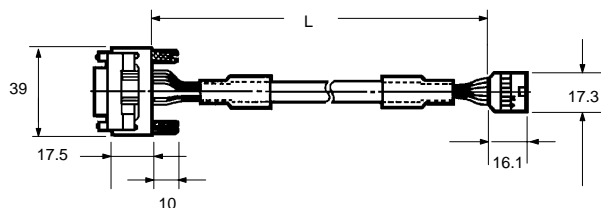

Connection Precautions

1, 2, 3...

1. Tighten the lock screws after inserting the connector into the Unit.
2. Push the connector firmly into the Data Setting Console until the clips fully lock.
3. Power is supplied through the connecting cable from the Heat/Cool Temperature Control Unit. Nothing appears on the Data Setting Console display if no power is supplied to input terminals A8 and A9 of the Heat/Cool Temperature Control Unit.
4. Install the supplied connector cover when the Data Setting Console is not in use.

SECTION 3

Data Setting Console Operation

This section provides the basic operating procedures of the Data Setting Console including parameter settings and displays.

3-1	Operating Procedure	20
3-2	Data Flow	21
3-3	Nomenclature and Features	22
3-3-1	Nomenclature	22
3-3-2	Features	23
3-4	Parameter Displays and Settings	24
3-4-1	Table of Parameters	24
3-4-2	How to Display and Set Parameter Data	26

3-1 Operating Procedure

After preparing the C200H PC, follow the procedure below to use the Heat/Cool Temperature Control Unit.

- 1, 2, 3...
 1. Set the switches on the front and rear panels according to the operating conditions. (Refer to *2-2 Switch Settings*.)
Set SW2-2 under the display cover to the OFF position to enable data setting from the Data Setting Console.
 2. Mount to Rack.
Turn off the C200H power supply before mounting or dismounting the C200H on the Rack.
 3. Connect the input wiring. (Refer to *2-3 Wiring*.)
The 24-VDC power supply must be connected. The Data Setting Console will not operate unless the 24-VDC power supply is connected. The sensors can be connected immediately before the system is tested.
 4. Connect the Data Setting Console. (Refer to *2-3-3 Data Setting Console Cables*.)
 5. Turn on the 24-VDC and the C200H power supplies.
Set the C200H to PROGRAM mode.
 6. Use the Data Setting Console to make the settings for the parameters that need to be changed. (Refer to the rest of this section.)
 7. Test operation and adjust data. (Refer to the rest of this section.)
Connect the output wiring and turn on the heater power. To start the test operation, turn ON the RUN bit of the loop that is to be controlled with a device such as the Programming Console. Monitor the control conditions and adjust the data until the required control is achieved. During operation, the "bank no." is switched to "executed bank no." and cannot be changed from the Data Setting Console. To change it, use a device such as the Programming Console, or use the user program.
 8. Create the user programs. (Refer to *Section 4 PC Memory Allocation and Programming*.)
Arrange the data for the test operation, and create the user programs for data setting, monitoring, switching the bank number, and so on. Set SW2-2 under the display cover to the ON position to enable data setting from the C200H PC.
 9. Start operation.

3-2 Data Flow

The data flow in the Heat/Cool Temperature Control Unit is shown in the diagram below.

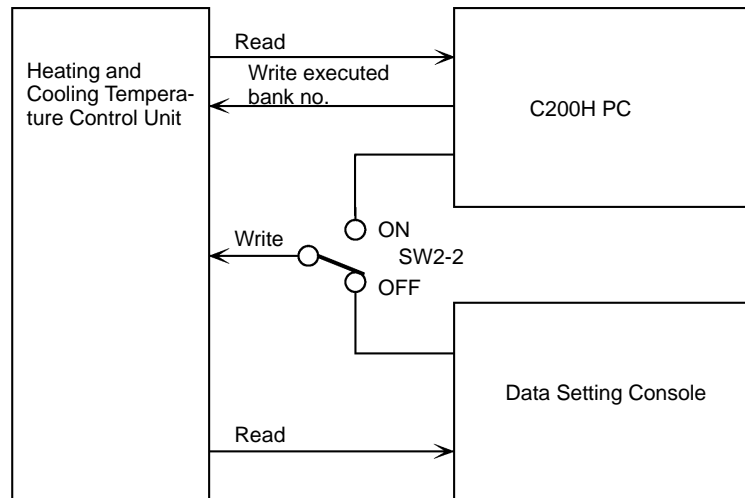

The read operation and setting the executed bank number are possible from a user program or from a device, such as the Programming Console, regardless of the ON/OFF setting of SW2-2.

Data written from the Data Setting Console and data written with write command when SW2-1 (switching memory contents) is set to Normal are written to the Heat/Cool Temperature Control Unit EEPROM and are consequently retained when the power supply is turned off.

The SP value set when SW2-1 (switching memory contents) is set to Fixed and executed bank number settings made from the C200H PC are written directly to RAM and are not saved to EEPROM. This data is lost when the power supply is turned off. The same data can be written to the RAM when the power is next turned on and executes a user program. Settings made from the Programming Console must be repeated each time the power is turned on.

Data Settings from Data Setting Console

Set SW2-2 under the display cover to the OFF position to enable data setting from the Data Setting Console.

The “bank no.” can be set when operation is stopped (i.e., when the RUN bit is OFF). During operation it is switched to “executed bank no.” and cannot be changed from the Data Setting Console. To change the executed bank number, use a user program or a device such as the Programming Console.

Operation begins when the RUN bit of the output relay turns ON. (For information on output relays, refer to *Section 4 PC Memory Allocation and Programming*.)

3-3 Nomenclature and Features

3-3-1 Nomenclature

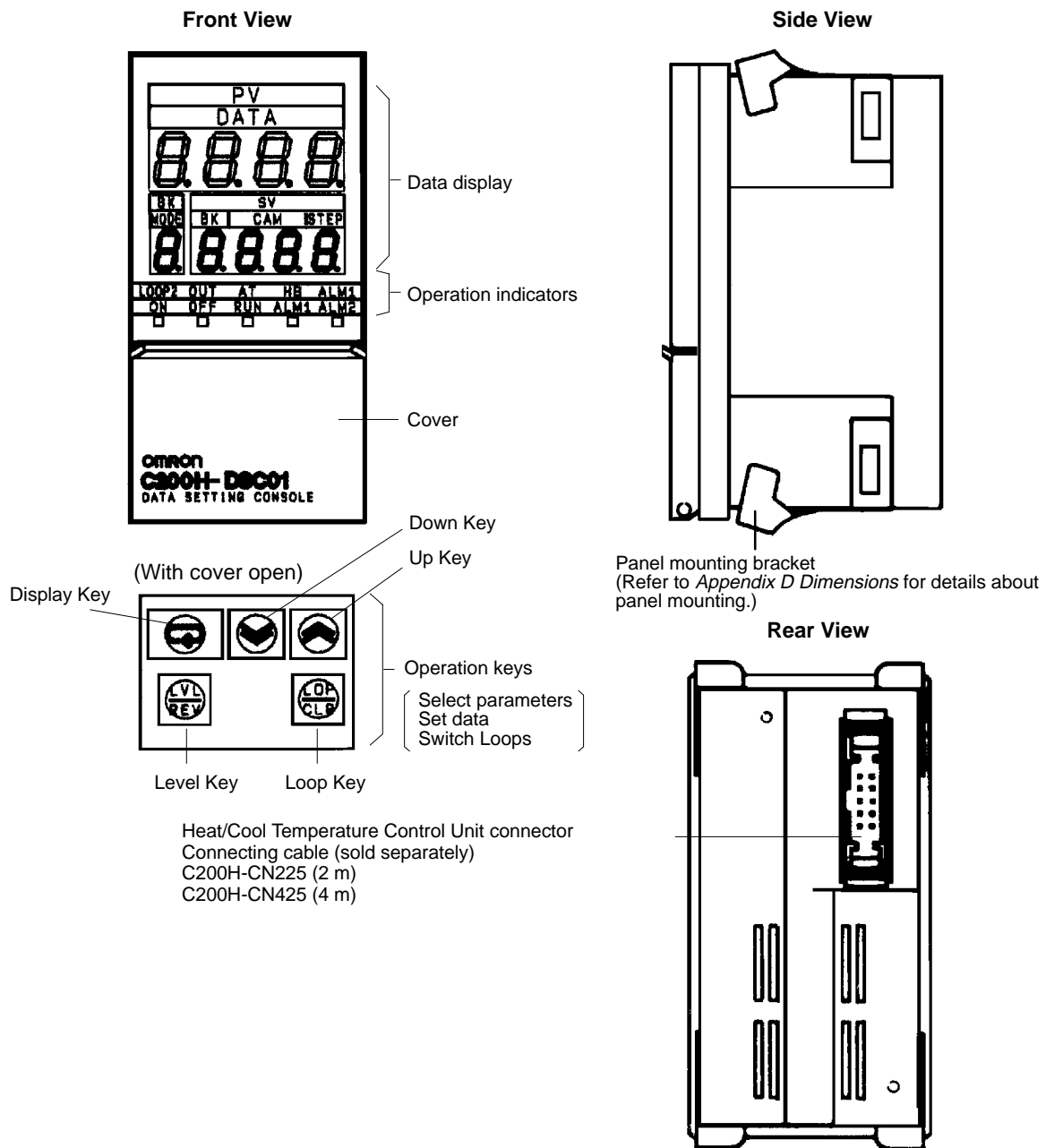

The bottom row of the operation keys have upper and lower labels. The upper labels apply to Heat/Cool Temperature Control Unit operation. The lower labels are for the Cam Positioner Unit.

Two display sheets are supplied: one for the Heat/Cool Temperature Control Unit and one for the Cam Positioner Unit. If the Data Setting Console is to be used with the Temperature Control Unit only, stick on the display sheet for the Heat/Cool Temperature Control Unit.

Note The Data Setting Console will not operate unless a 24-VDC power supply is connected to the Heat/Cool Temperature Control Unit input terminals.

3-3-2 Features

Data Display

Name	Function
PV (Process Value)	Displays the PV or the parameter symbol selected with the Level or Display Key (Refer to next page).
SV (Set Value)	The display is as follows, according to the PV display contents. PV (process value): SV (set value) is displayed. Parameter symbol: Setting/monitor data is displayed.
BK (Bank Number)	Displays the bank number of the data presently being displayed. During operation, the executed bank number is displayed. (See note)

Note Operation begins when the RUN bit of the output relay turns ON.

Operation Indicators



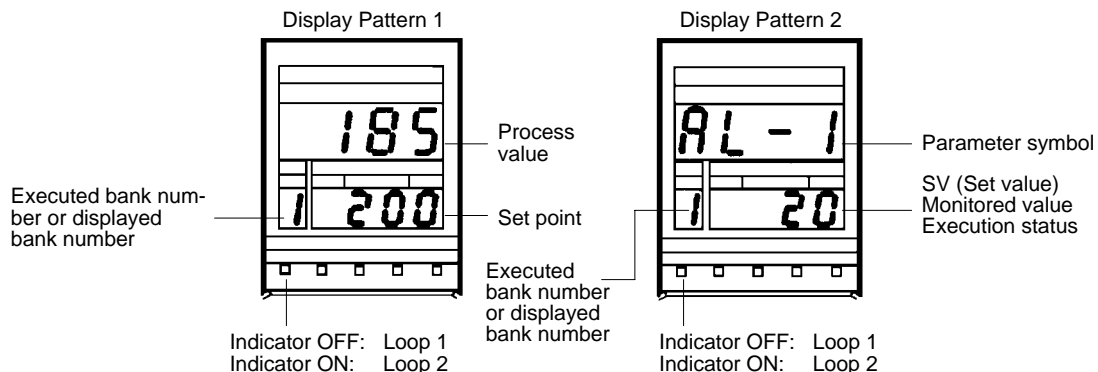

Name	Function
LOOP2	Indicates whether the displayed settings relate to Loop 1 or Loop 2. Press the Loop Key and hold down for approximately 2 seconds to switch between Loop 1 and Loop 2. Indicator OFF: Loop 1 Indicator ON: Loop 2
OUT (Output)	Turns ON when the heating output is ON for transistor output or voltage output types.
AT (Auto-tuning)	Blinks at approximately 1 second intervals during auto-tuning.
HB (Heater Burnout)	Turns ON to indicate a heater burnout alarm.
ALM1 (Alarm)	Turns ON to indicate the temperature is in the alarm range set with Alarm SV 1 (upper- and lower-limit alarm). Refer to the following page.

These indicators relate to the currently displayed loop.

Display Patterns



Operation Keys

Name	Function
Level Key 	The parameter items are divided into three display groups (Refer to display levels 0 to 2 on the next page). Press this key to switch from one group to another. The display levels automatically cycle in the sequence 0 → 1 → 2 → 0 when the key is held down for approximately 2 seconds.
Display Key 	Press this key to select the required parameter from the selected display level 0 to 2 (Refer to table below). The parameters cycle automatically when the key is held down.
Loop Key 	Press this key for approximately two seconds to switch between Loop 1 and Loop 2.
Up Key 	Press this key to increment SV. The SV increment continuously while the key is held down. The SV display blinks when the value reaches its upper limit.
Down Key 	Press this key to decrement an SV. The SV decreases continuously while the key is held down. The SV display blinks when the value reaches its lower limit.

3-4 Parameter Displays and Settings

3-4-1 Table of Parameters

Display level	Parameter	Display symbol	Write	Read	Loop no.	Bank no.	Data range	Default value	Page
0	Set point	---	Yes	Yes	Yes	Yes	SP lower limit to SP upper limit	0°C	26
	Bank number	b^H	See note 5	Yes	Yes	No	1 to 8	1	26
	Alarm SV 1 (see note 4)	$AL-1$	Yes	Yes	Yes	Yes	Alarm mode TC 1, 4, 5: 0° to 9999°C Other TCs: -999° to 9999°C	0°C	27
	Alarm SV 2 (see note 4)	$AL-2$	Yes	Yes	Yes	Yes	Pt 1, 4, 5: 0.0° to 999.9°C Other Pts: -99.9° to 999.9°C	0°C	
	Input shift value	$\bar{c}n-5$	Yes	Yes	Yes	Yes	-99.9° to 999.9°C	0.0°C	27
	Proportional band (see note 1)	P	Yes	Yes	Yes	Yes	0.0° to 999.9°C	40.0°C	27
	Integral (reset) time (see note 1)	\bar{c}	Yes	Yes	Yes	Yes	0 to 9999 s	240 s	
	Derivative (rate) time (see note 1)	d	Yes	Yes	Yes	Yes	0 to 9999 s	40 s	
1	SP lower limit	$SL-L$	Yes	Yes	Yes	No	Sensor measuring range lower limit to (SP upper limit - 1 digit)	TC: -200°C Pt: -99.9°C	28
1	SP upper limit	$SL-H$	Yes	Yes	Yes	No	(Sensor measuring range lower limit + 1 digit) to SP upper limit	TC: 1,300°C Pt: 450.0°C	28

Display level	Parameter	Display symbol	Write	Read	Loop no.	Bank no.	Data range	Default value	Page
	Dead band (see note 1)	$\bar{C}-db$	Yes	Yes	Yes	No	TC: -999 to 9999°C Pt: -99.9 to 999.9°C	0°C	28
	Cooling coefficient (see note 1)	$\bar{C}-5\bar{C}$	Yes	Yes	Yes	No	0.01 to 99.99	1.00	29
	Heating control period (see notes 1 and 3)	$\bar{C}P$	Yes	Yes	Yes	No	1 to 99 s	20 s	29
	Cooling control period (see notes 1 and 3)	$\bar{C}-\bar{C}P$	Yes	Yes	Yes	No	1 to 99 s	20 s	29
	Hysteresis (see note 2)	HYS	Yes	Yes	Yes	Yes	0.0° to 999.9°C	0.8°C	29
	Alarm hysteresis (see note 4)	$HYSR$	Yes	Yes	Yes	No	0.0° to 999.9°C	0.2°C	30
	Heater current monitor (see note 3)	$\bar{C}t$	No	Yes	Yes	No	0.0 to 55.0 A	0.0 A	30
	Heater burnout current (see note 3)	Hb	Yes	Yes	Yes	No	0.0 to 50.0 0.0: No heater burnout detection, alarm signal OFF 50.0: No heater burnout detection, alarm signal ON	0.0 A	
2	Heating output variable monitor	$H-\bar{O}$	No	Yes	Yes	No	0.0% to 100.0%	0.0 %	31
	Cooling output variable monitor	$\bar{C}-\bar{O}$	No	Yes	Yes	No	0.0% to 100.0%	0.0 %	31
	Auto-tuning start/stop (see note 1)	Rt	Yes	Yes	Yes	No	---	---	31
	Copy bank	$b\bar{C}PY$	Yes	Yes	Yes	No	---	---	31
	Input-type monitor	$\bar{C}n-\bar{t}$	No	Yes	No	No	0 to 9	Setting for SW202	
	Alarm 1 mode	$ALt1$	Yes	Yes	Yes	No	0 to 9	2	32
	Alarm 2 mode	$ALt2$	Yes	Yes	Yes	No		2	

Yes: Possible.

No: Not possible or not required.

- Note**
1. Only when advanced PID control is selected. (switch 203-1 = OFF)
 2. Only when ON/OFF control is selected. (switch 203-1 = ON)
 3. Valid only for C200H-TV 03 (current output type).
 4. Does not apply when Alarm Mode = 0.
 5. Writing is not possible during operation (i.e., when RUN is ON).
 6. Thermocouple = TC
Platinum Resistance Thermometer = Pt

3-4-2 How to Display and Set Parameter Data

Basic Operation

When not specifically explained, use the keys as described in the following.

Changing the Display Level

When the Level Key is pressed, the leading parameter for each level is displayed.

Changing Parameters

When the Display Key is pressed, the parameters are displayed in order. There may be skips depending on the model and DIP switch settings.

Changing the SV

Pressing the Up Key or the Down Key changes the SV. The SV is retrieved automatically.

Changing the Loop

The loop is switched each time the Loop Key is pressed. It can be confirmed by means of the LOOP 2 indicator.

PV and SV (Display Level 0)

PV	198	---	Process temperature (monitored every 500 ms)
SV	200	---	Set point of currently selected bank and loop (unit: °C or °F)

Valid SV Range

Set the set point in the range between the SV lower limit and the SV upper limit.

Error Display

When a sensor error occurs, one of the codes below and the detected temperature blink alternately in the PV display.

<i>SEr1</i>	Temperature is out of the range: (sensor measurement range + 10%FS). That is, 10%FS below the lower limit or 10%FS above the upper limit. Includes broken or incorrect sensor wiring.
<i>SEr2</i>	ser1: Loop1 or Loop1 and Loop2 simultaneously. ser2: Loop2
<i>SErr</i>	Abnormality in the cold junction compensating circuit. Applies to thermocouple type only.

Bank Number (Display Level 0)

PV	b4	---	Bank number parameter symbol
SV	1	---	Currently set bank number. During control operation: Executed bank number Control operation interrupted: Currently displayed bank number

Settings



- The bank number can be changed.
- The changed SV is reflected in the bank number display (BK).

Bank Number and Executed Bank Number

The executed bank number cannot be changed from the Data Setting Console.

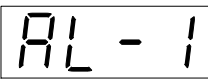

When changing these parameters from the Data Setting Console, stop operation. While operation is stopped, the bank number setting can be changed.

Alarm SV 1 (Display Level 0)

PV		---	Alarm 1 parameter symbol
SV		---	Alarm SV of currently selected bank and loop (unit: °C or °F)

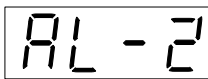

Not valid when Alarm mode = 0.

Alarm SV 2 (Display Level 0)

PV		---	Alarm 2 parameter symbol
SV		---	Alarm SV of currently selected bank and loop (unit: °C or °F)

Not valid when Alarm mode = 0.

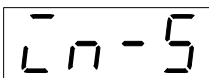
Input Shift Value (Display Level 0)

PV		---	Input shift value parameter symbol
SV		---	Input shift value of currently selected bank and loop (unit: °C or °F)

If the displayed temperature value differs from the actual temperature value due to the sensor position or some other conditions, set the input shift value such that the correct temperature is displayed.

Proportional Band (Display Level 0)

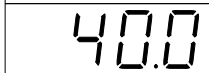
PV		---	Proportional band parameter symbol
SV		---	Proportional band of currently selected bank and loop (unit: °C or °F)

- This sets the proportional band. It is valid only when SW203-1 is set to OFF (i.e., PID control).
- This value is reflected even when auto-tuning (AT) is executed.
- If this value is set to "0.0," ON/OFF control is executed.

Integral (Reset) Time (Display Level 0)

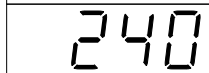
PV		---	Integral time parameter symbol
SV		---	Integral time of currently selected bank and loop (unit: second)

- This sets the integral time. It is valid only when SW203-1 is set to OFF (i.e., PID control).
- This value is reflected even when auto-tuning (AT) is executed.

Derivative (Rate) Time (Display Level 0)

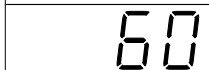
PV		---	Derivative time parameter symbol
SV		---	Derivative time of currently selected bank and loop (unit: second)

- This sets the integral time. It is valid only when SW203-1 is set to OFF (i.e., PID control).
- This value is reflected even when auto-tuning (AT) is executed.

SP Lower Limit (Display Level 1)

PV	5L-L	---	SP lower limit parameter symbol
SV	-200	---	SP lower limit of currently selected loop (unit: °C or °F)

- Settings can be made within the following range:
Sensor measuring range lower limit to (SP upper limit – 1 digit)
- When powering up or starting, the lower limit of the measuring range for sensors set by the rear-panel SW202 (sensor type) is set automatically. For example, if SW202 is set to “2,” the thermocouple type is set to “–200.” However, the SP lower limit will not be changed if the current SV lies inside the sensor measuring range.

SP Upper Limit (Display Level 1)

PV	5L-H	---	SP upper limit parameter symbol
SV	1300	---	SP upper limit of currently selected loop (unit: °C or °F)

- Settings can be made within the following range:
(SP limit + 1 digit) to sensor measuring range upper limit
- When powering up or starting, the upper limit of the measuring range for sensors set by the rear-panel SW202 (sensor type) is set automatically. For example, if SW202 is set to “2,” the thermocouple type is set to “1300.” However, the SP upper limit will not be changed if the current SV lies inside the sensor measuring range.

Dead Band (Display Level 1)

PV	[-db	---	Dead band parameter symbol
SV	0	---	Dead band of currently selected loop (unit: °C or °F)

- This sets the cooling output dead band, and it is valid when SW203-1 (PID control) is OFF.
- The relation between the dead band and the set temperature is as shown in the illustration below.

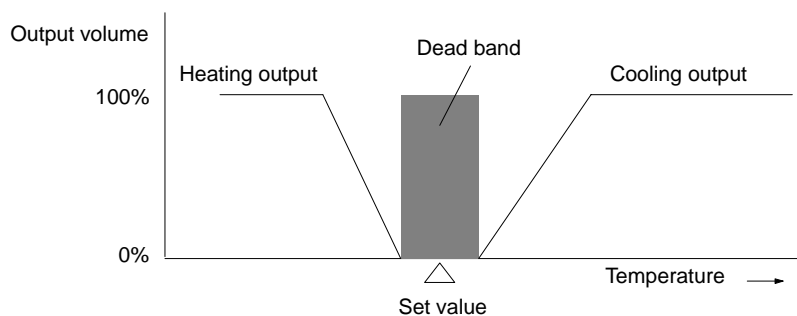

Cooling Coefficient (Display Level 1)

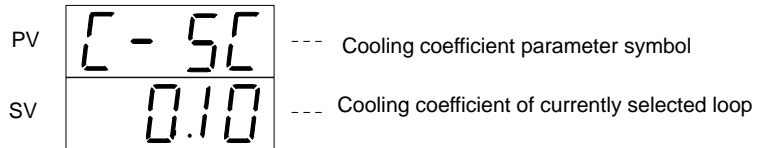

- This sets the coefficient for finding the cooling P constant. It is valid when SW203-1 is OFF (PID control). The formula for calculating the cooling P constant is as follows:
Cooling P constant = heating P constant x cooling coefficient
- The I/D constant is the same for cooling as for heating.

Control Period (Display Level 1)

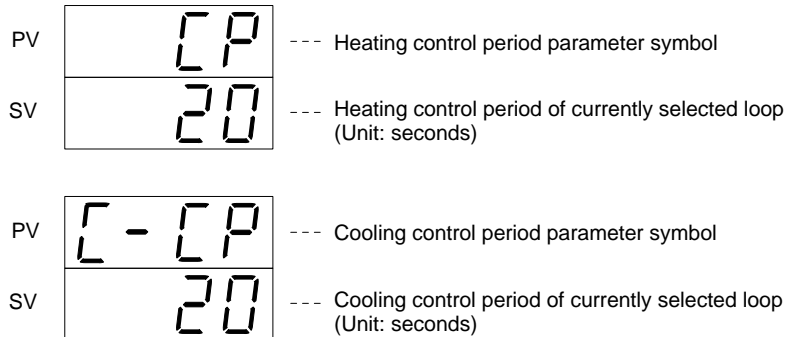

- This sets the control period. It is valid when SW203-1 is OFF (PID control), and only when the heater model is not the C200H-TV 03 (current output type).
- Cooling loop 1 is invalid when SW203-6 is ON (current output).
- The control period is the time required to complete one transistor output or voltage output ON/OFF cycle.

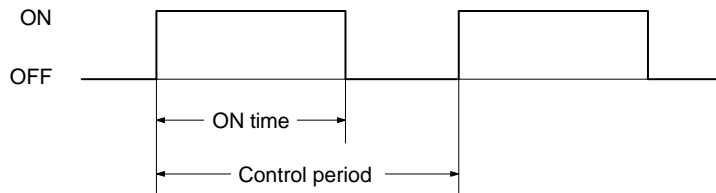

Hysteresis (Display Level 1)

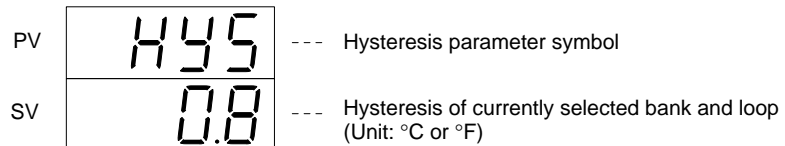

- Hysteresis prevents control output chattering and eliminates noise influences.
- When switching from ON to OFF, operation proceeds at the set point. When switching from OFF to ON, operation proceeds at a lower point determined by the hysteresis SV, as shown in the following illustration.

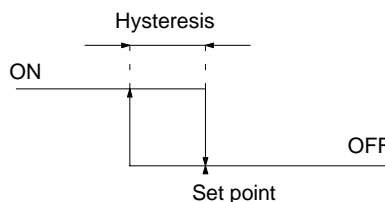

Hysteresis is applied in the following situations.

- When ON/OFF control is selected (i.e., when SW203-1 is ON).
- When advanced PID control is selected (i.e., when SW203-1 is OFF) and P (proportional band) is 0.

Alarm Hysteresis (Display Level 1)

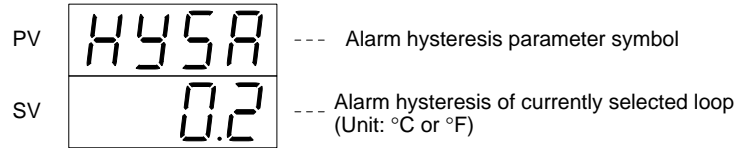

- Alarm hysteresis prevents alarm output chattering and eliminates noise influences. It is invalid when both alarm mode 1 and alarm mode 2 are “0.”
- When switching from OFF to ON, operation proceeds at the set point. When switching from ON to OFF, a hysteresis SV operating band is provided which may be either higher or lower than the set point, depending on the alarm mode.

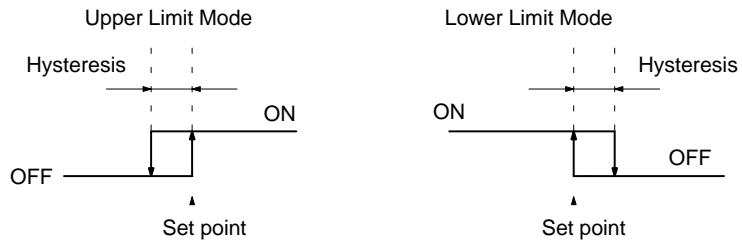

The alarm output is OFF if the present temperature lies within the hysteresis band when the Unit is turned on.

Heater Current Monitor (Display Level 1)

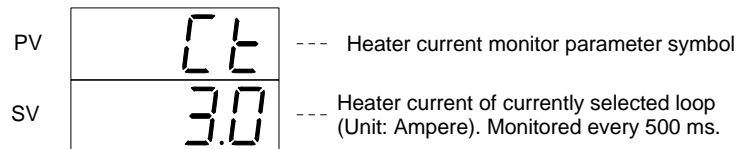

Note Cannot be set.

- Valid for C200H-TV 03 (current output type).

Heater Burnout Detection Current (Display Level 1)

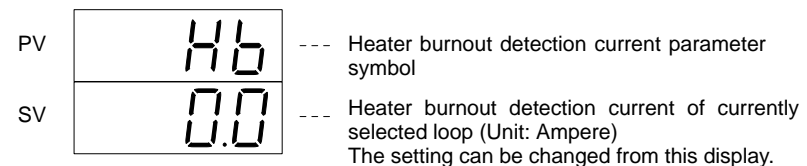

- Invalid for C200H-TV 03 (current output type).
- Make the setting using one of the two values shown in the table below. Refer to *Appendix C Heater Burnout Detection* for more details about the alarm SVs.

0.0	No heater burnout detection. Alarm signal OFF.
50.0	No heater burnout detection. Alarm signal ON.

Control Output Variable Monitor (Display Level 2)

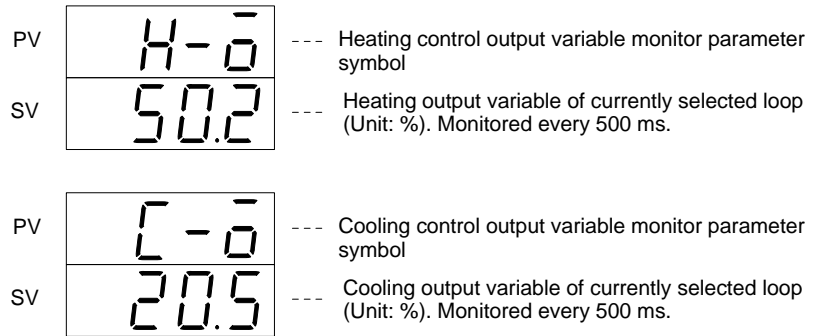

The relationship between the control output variable and control period is defined by the formula below:

$$\text{Control output variable (\%)} = \frac{\text{ON time}}{\text{Control period}} \times 100$$

The control output variable during ON/OFF control (when SW203-1 on the rear panel is ON) is ON = 100% and OFF = 0%.

Auto-tuning Start/Stop (Display Level 2)

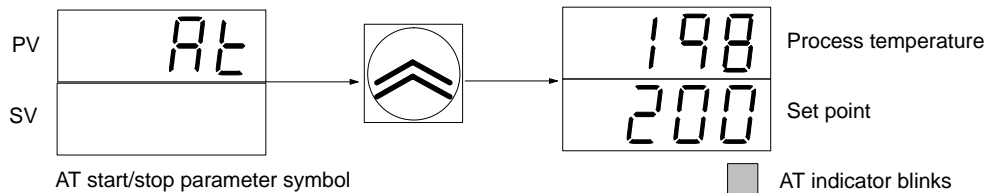

- The auto-tuning operation begins when the Up Key is pressed. The PV and SV return to the respective present temperature and set point displays. While auto-tuning is in progress the AT indicator blinks.
- To interrupt, press the Level and Display Keys again to display at. When at appears, press the Up Key. When the interrupt is executed, the AT display disappears and the process temperature is displayed.
- When auto-tuning is completed, the AT indicator stops blinking and the P, I, and D data is written to EEPROM.

Copy Bank (Display Level 2)

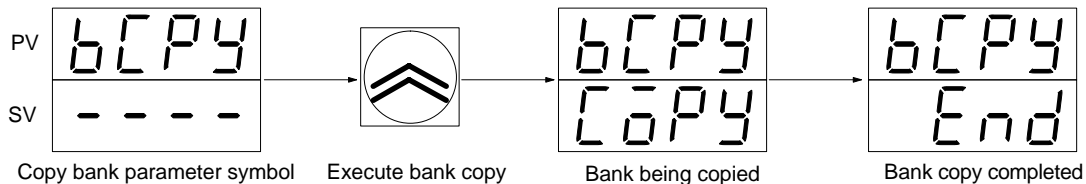

- When the Up Key is pressed, the data other than the set point is copied from bank number 1 to banks 2 through 8.
- Use this method to create data in banks 2 through 8 by slightly modifying the data in bank number 1.

Input-type Monitor (Display Level 2)

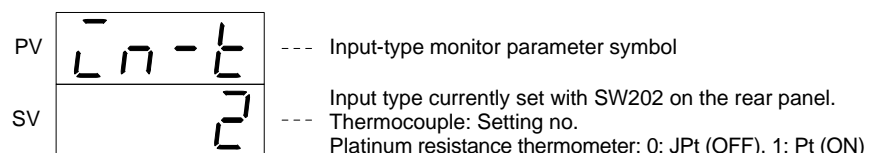

Note Cannot be set.

Alarm 1 and Alarm 2 Modes (Display Level 2)

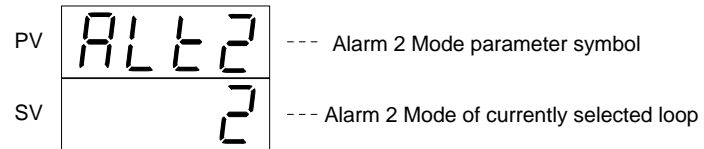
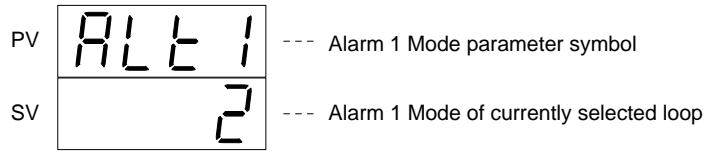

Select the desired alarm type from the following chart and set the number (X: set value)

Alarm Mode	Alarm Type	Alarm Range	
		0	SP
0	No alarm		
1	Upper- and lower-limit alarm		
2	Upper-limit alarm		
3	Lower-limit alarm		
4	Upper- and lower-limit range alarm		
5	Upper- and lower-limit alarm with standby sequence		
6	Upper-limit alarm with standby sequence		
7	Lower-limit alarm with standby sequence		
8	Absolute-value upper-limit alarm		
9	Absolute-value lower-limit alarm		

Standby Sequence

When the power is turned on, the temperature is below the set point, so alarm output status occurs with regard to the lower limit alarm. In this situation, if “lower limit alarm with standby sequence” is selected, the standby sequence recognizes that the value is out of the alarm range and then outputs an alarm when the value enters the alarm range once more.

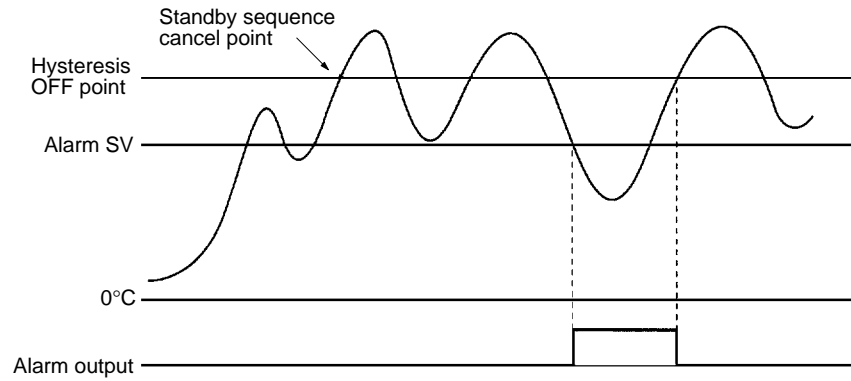
Lower Limit Alarm with Standby Sequence

The standby sequence is restarted in the following situations.

- When the power is turned on.
- When the set point is changed.
- When the executed bank number is changed.
- When the alarm mode is changed.
- When changing from stop to run.

SECTION 4

PC Memory Allocation and Programming

This section provides the C200H PC's memory allocation for the Heat/Cool Temperature Control Unit. Basic programming procedures and examples are also provided.

4-1	Memory Allocation	36
4-1-1	Memory Allocation Table	37
4-1-2	Memory Contents	38
4-1-3	Table of Commands	41
4-2	Data Flow	43
4-3	Programming	43
4-3-1	Example with SW2-1 in the Fixed Position	43
4-3-2	Example 1: Write with SW2-1 in the Normal Position	44
4-3-3	Example 2: Read with SW2-1 in the Normal Position	47
4-3-4	Operation Timing	50

4-1 Memory Allocation

Memory Allocation

According to the Unit number switch setting on the front of the C200H Heat/Cool Temperature Control Unit, 10 words are allocated for each Unit number in the Special I/O Unit IR area between IR100 to IR199, which is used as the I/O refresh data area. The IR area used by the C200H Temperature Control Unit is refreshed on each C200H PC I/O refresh cycle.

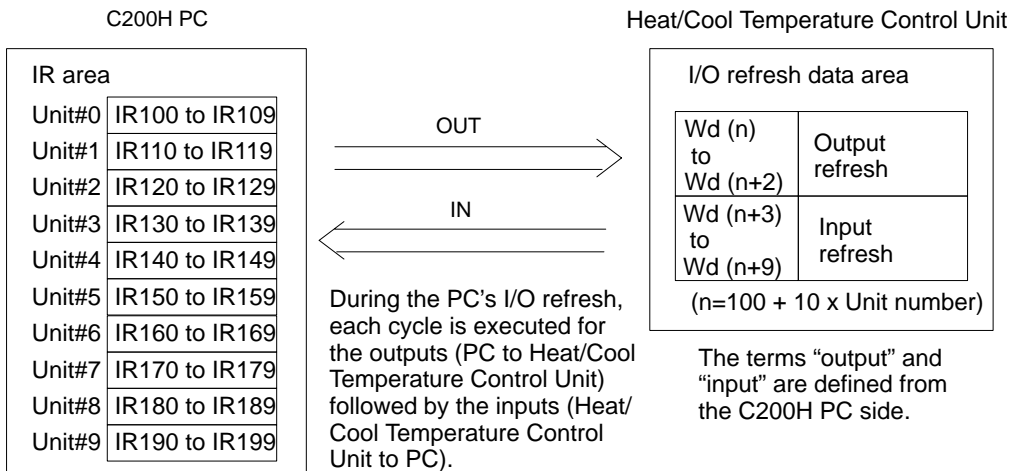

Note A Duplicate I/O Unit error occurs if the set Unit number corresponds to the number of an existing Special I/O Unit.

Selecting Allocated Data

The data allocated to each IR word due to the Unit number setting is determined by the setting of SW2-1 on the front of the Unit.

ON	Normal	All data can be set using commands.
OFF	Fixed	Parameters are fixed for the set point (SP).

This setting becomes valid immediately when the switch is set.

4-1-1 Memory Allocation Table

SW2-1 in Fixed Position

(n=100 + 10 x Unit number)

I/O	Word	Bit																	
		15	14	13	12	11	10	09	08	07	06	05	04	03	02	01	00		
Output	n	Loop 1 SP (see note)																	
		0 to 9, F				0 to 9				0 to 9				0 to 9					
	n+1	Loop 2 SP (see note)																	
		0 to 9, F				0 to 9				0 to 9				0 to 9					
	n+2	Loop 1 executed bank number				Loop 2 executed bank number				Loop 1		Loop 2		0					
		0		RUN		0		RUN		0									
Input	n+3	Loop 1 PV (see note)																	
		0 to 9, F				0 to 9				0 to 9				0 to 9					
	n+4	Loop 2 PV (see note)																	
		0 to 9, F				0 to 9				0 to 9				0 to 9					
	n+5	Loop 1 SP (see note)																	
		0 to 9, F				0 to 9				0 to 9				0 to 9					
	n+6	Loop 2 SP (see note)																	
		0 to 9, F				0 to 9				0 to 9				0 to 9					
	n+7	Loop 1 executed bank number				Loop 2 executed bank number				0				0		0		SW2	
																2	1		
	n+8	Loop 1 status data																	
		0	Sen- sor error	CT over- flow	0	0			RUN	0	0	Coo ling out- put	Hea ting out- put	AT	HB	AL1	AL2		
	n+9	Loop 2 status data																	
		0	Sen- sor error	CT over- flow	0	0			RUN	0	0	Coo ling out- put	Hea ting out- put	AT	HB	AL1	AL2		

Note For four-digit BCD and platinum resistance thermometer data, the least significant digit = 0.1, and the most significant digit (F) = minus (-). For example, "F200" represents -20.0°C for a platinum resistance thermometer.

SW2-1 in Normal Position

(n=100 + 10 x Unit number)

I/O	Word	Bit															
		15	14	13	12	11	10	09	08	07	06	05	04	03	02	01	00
Output	n	Read/write instruction															
		Read/write		Loop no.				Bank no.				Instruction					
	n+1	Write data (see note)															
		0 to 9, F				0 to 9				0 to 9				0 to 9			
n+2	Loop 1 executed bank number				Loop 2 executed bank number				0	Loop 1 RUN	0	Loop 2 RUN	0	0	0	Write re- quest	
Input	n+3	Loop 1 PV (see note)															
		0 to 9, F				0 to 9				0 to 9				0 to 9			

I/O	Word	Bit															
		15	14	13	12	11	10	09	08	07	06	05	04	03	02	01	00
Input	n+4	Loop 2 PV (see note)															
		0 to 9, F				0 to 9				0 to 9				0 to 9			
	n+5	Read data (see note)															
		0 to 9, F				0 to 9				0 to 9				0 to 9			
	n+6	0				Write error	0	0	Write complete	0				0	0	0	Read complete
	n+7	Loop 1 executed bank number				Loop 2 executed bank number				0				0	0	SW2	
														2	1		
	n+8	Loop 1 status data															
		0	Sensor error	CT overflow	0	0	RUN		0	0	Cooling output	Heating output	AT	HB	AL1	AL2	
	n+9	Loop 2 status data															
0		Sensor error	CT overflow	0	0	RUN		0	0	Cooling output	Heating output	AT	HB	AL1	AL2		

Note For four-digit BCD and platinum resistance thermometer data, the least significant digit = 0.1, and the most significant digit (F) = minus (-). For example, "1000" represents 100.0°C for a platinum resistance thermometer.

4-1-2 Memory Contents

SW2-1 in Fixed Position

(n=100 + 10 x Unit number)

I/O	Address		Data item	Data contents
	Word	Bit		
Output	n	15 to 00	Loop 1 SP	Sets the Loop 1 and Loop 2 SP (set point) as 4-digit BCD data. For platinum resistance thermometer data, the least significant digit is 0.1. Set the most significant digit to F for minus (-). Note These specified values apply to the bank number set with Wd (n+2) and can be written directly to RAM. (Refer page 43)
	n+1	15 to 00	Loop 2 SP	
	n+2	15 to 12	Loop 1 executed bank number	Sets the bank number executed for Loop 1 and Loop 2 as 1-digit BCD data. Set executed bank numbers from 1 to 8. If the value is set out of this range, the bank number reverts to the previous value.
		11 to 08	Loop 2 executed bank number	
		07	---	Not used. Set to 0.
		06	Loop 1 RUN	This the Loop 1 Run/Stop bit. When it is set to 1, operation starts; when it is set to 0, operation stops.
		05	---	Not used. Set to 0.
		04	Loop 2 RUN	This the Loop 2 Run/Stop bit. When it is set to 1, operation starts; when it is set to 0, operation stops.
	03 to 00	---	Not used. Set to 0.	

I/O	Address		Data item	Data contents		
	Word	Bit				
Input	n+3	15 to 00	Loop 1 PV	Outputs the Loop 1 and Loop 2 PV (process value) as 4-digit BCD data. For platinum resistance thermometer data, the least significant digit is 0.1. The most significant digit is F for minus (-).		
	n+4	15 to 00	Loop 2 PV			
	n+5	15 to 00	Loop 1 SP	Outputs the Loop 1 and Loop 2 SP (set point) as 4-digit BCD data. For platinum resistance thermometer data, the least significant digit is 0.1. The most significant digit is F for minus (-).		
	n+6	15 to 00	Loop 2 SP			
	n+7	15 to 12	Loop 1 executed bank number	Outputs the bank number currently executed for Loop 1 and Loop 2 as 1-digit BCD data.		
			Loop 2 executed bank number			
		07 to 02	---			Not used. Each bit is set to 0.
		01	SW2-2			Outputs the ON/OFF status of SW2-2 (setting direction). 0: Data Setting Console 1: C200H PC
		00	SW2-1			Outputs the ON/OFF status of SW2-1 (switching memory contents). 0: Fixed 1: Normal
	n+8 Loop 1 n+9 Loop 2	15	---	Not used. Set to 0.	Loop 1/2 status data	
		14	Sensor error	Bit set to 1 if the sensor is not connected, a sensor wire is broken, or the input data exceeds the operational temperature range.		
		13	CT overflow	Bit set to 1 when the detected heater current exceeds 55.0 A.		
		12 to 09	---	Not used. Each bit is set to 0.		
		08	RUN	Bit set to 1 during operation.		
		07 and 06	---	Not used. Each bit is set to 0.		
		05	Cooling control output	Bit set to 1 when the control output (transistor or voltage output) is ON.		
04		Heating control output				
03		AT	Bit set to 1 during auto-tuning (AT).			
02		HB	Bit set to 1 if the detected heater current drops below the set heater burnout current value. (HB: heater burnout)			
01	AL1	Bit set to 1 when the temperature enters the set alarm range (Refer to page 23).				
00	AL2					

Note If the setting direction of the Temperature Control Unit is set to the C200H PC and the C200H is in program mode, all word data will be 0. Therefore, if the C200H in program mode has been set to continuous control, the Temperature Control Unit executes temperature control when the C200H stops operating, judging that the SP has been changed to 0°C. To prevent this, set SW2-2 of the Temperature Control Unit to OFF (i.e., the setting direction is set to the Data Setting Console) before the C200H stops operating and reset SW2-2 after the C200H restarts.

SW2-1 in Normal Position

(n=100 + 10 x Unit number)

I/O	Address		Data item	Data contents	
	Word	Bit			
Output	n	15 and 14	Read/Write	The data bit sets operation to read or write. Write = 01 Read = 00	Read/Write command
		13 and 12	Loop no.	The data bit sets the Loop Number to which the read or write operation applies. Loop 1 = 01, Loop 2 = 10	
		11 to 08	Bank no.	Sets the bank number to which the read or write operation applies as 1-digit BCD data. Set executed bank numbers from 1 to 8.	Read/Write command
		07 to 00	Command	Sets the command code (Refer to page 41) for the read or write operation as 2-digit BCD data.	
	n+1	15 to 00	Write data	Set the SP for a write operation as 4-digit BCD data. The least significant digit of the actual data matches the least significant digit of the set value. Set the most significant digit to F for minus (-) values. The write operation commences when the write request flag (Wd (n+2), bit 00) turns ON.	
	n+2	15 to 12	Loop 1 executed bank number	Set the bank number currently executed for Loop 1 and Loop 2 as 1-digit BCD data. Executed bank numbers are from 1 to 8. If the value is set out of this range, the bank number reverts to the previous value.	
			Loop 2 executed bank number		
		07	---	Not used. Set to 0.	
		06	Loop 1 RUN	This the Loop 1 Run/Stop bit. When it is set to 1, operation starts; when it is set to 0, operation stops.	
		05	---	Not used. Set to 0.	
		04	Loop 2 RUN	This the Loop 2 Run/Stop bit. When it is set to 1, operation starts; when it is set to 0, operation stops.	
		03 to 01	---	Not used. Set to 0.	
		00	Write request	Turn this bit ON to write the data in Wd (n+1), by means of this command. Turn this bit OFF after the Write Complete Flag (Wd (n+6), bit 08) turns ON.	
	Input	n+3	15 to 00	Loop 1 PV	Outputs the Loop 1 and Loop 2 PV (process value) as 4-digit BCD data. For platinum resistance thermometer data, the least significant digit is 0.1. Set the most significant digit to F for minus (-) values.
n+4		15 to 00	Loop 2 PV		
n+5		15 to 00	Read data	Outputs the data read with the commands set with Wd (n). The least significant digit of the actual data matches the least significant digit of the set value. Set the most significant digit to F for minus (-) values.	
n+6		15 to 12	---	Not used. Each bit is set to 0.	
		11	Write error	Bit set to 1 when the write data exceeds the set permissible range. The bit is automatically set to 0 when the Write Request Flag (Wd (n+2), bit 00) turns OFF.	
		10 and 09	---	Not used. Each bit is set to 0.	
		08	Write complete	Bit set to 1 when the write operation executed by means of the command set with Wd (n) ends normally. The bit is automatically set to 0 when the Write Request Flag (Wd (n+2), bit 00) turns OFF.	

I/O	Address		Data item	Data contents		
	Word	Bit				
Input	n+6	07 to 01	---	Not used. Each bit is set to 0.		
		00	Read complete	Bit set to 1 when the read operation executed by means of the command set with Wd (n) ends normally. The bit is automatically set to 0 when the next command is set.		
	n+7	15 to 12	Loop 1 executed bank number	Outputs the bank number currently executed for Loop 1 and Loop 2 as 1-digit BCD data.		
		11 to 08	Loop 2 executed bank number			
		07 to 02	---	Not used. Each bit is set to 0.		
		01	SW2-2	Outputs the ON/OFF status of SW2-2 (setting direction). 0: Data Setting Console 1: C200H PC		
		00	SW2-1	Outputs the ON/OFF status of SW2-1 (switching memory contents). 0: Fixed 1: Normal		
	n+8 Loop 1 n+9 Loop 2	15	---	Not used. Set to 0.		Loop 1/2 status data
		14	Sensor error	Bit set to 1 if the sensor is not connected, a sensor wire is broken, or the input data exceeds the operational temperature range.		
		13	CT overflow	Bit set to 1 when the detected heater current exceeds 55.0 A.		
		12 to 09	---	Not used. Each bit is set to 0.		
		08	RUN	Bit set to 1 during operation.		
		07 and 06	---	Not used. Each bit is set to 0.		
		05	Cooling control output	Bit set to 1 when the control output (transistor or voltage output) is ON.		
		04	Heating control output			
		03	AT	Bit set to 1 during auto-tuning (AT).		
		02	HB	Bit set to 1 if the detected heater current drops below the set heater burnout current value. (HB: heater burnout)		
	01	AL1	Bit set to 1 when the temperature enters the set alarm range (Refer to page 23).			
	00	AL2				

4-1-3 Table of Commands

The command codes shown below are set in bits (n Wd) 07 to 00 when the SW2-1 (switching memory contents) on the front panel is set in the Normal position.

Parameter	Command		Write	Read	Loop no.	Bank no.	Actual data range	Write/Read data range	Default value
Set point	0	0	Yes	Yes	Yes	Yes	SV lower limit to SV upper limit		0°C
Executed bank number	0	2	Yes	Yes	Yes	No	1 to 8	0001 to 0008	1

Parameter	Command		Write	Read	Loop no.	Bank no.	Actual data range	Write/Read data range	Default value
Alarm SV 1 (see note 4)	0	3	Yes	Yes	Yes	Yes	Alarm mode TC 1, 4, 5: 0 to 9999°C Other TCs: -999 to 9999°C	0000 to 9999 F999 to 9999	0°C
Alarm SV 2 (see note 4)	0	4	Yes	Yes	Yes	Yes	Pt 1, 4, 5: 0.0 to 999.9°C Other Pts: -99.9 to 999.9°C		0°C
Input shift value	0	5	Yes	Yes	Yes	Yes	-99.9 to 999.9°C	F999 to 9999	0.0°C
Proportional band (see note 1)	0	6	Yes	Yes	Yes	Yes	0.0 to 999.9°C	0000 to 9999	40.0°C
Integral (reset) time (see note 1)	0	7	Yes	Yes	Yes	Yes	0 to 9999 s	0000 to 9999	240 s
Derivative (rate) time (see note 1)	0	8	Yes	Yes	Yes	Yes	0 to 9999 s	0000 to 9999	40 s
SP lower limit	1	0	Yes	Yes	Yes	No	Sensor measuring range lower limit to (SP upper limit value - 1 digit)		TC: -200°C Pt: -99.9°C
SP upper limit	1	1	Yes	Yes	Yes	No	(SP lower limit + 1 digit) to sensor measuring range upper limit		TC: 1,300°C Pt: 450.0°C
Dead band (see note 1)	1	C	Yes	Yes	Yes	No	TC: -999 to 9999°C Pt: -99.9 to 999.9°C	F999 to 9999	0°C
Cooling coefficient (see note 1)	1	D	Yes	Yes	Yes	No	0.01 to 99.99	0001 to 9999	1.00
Heating control period (see notes 1 and 3)	1	7	Yes	Yes	Yes	No	1 to 99 s	0001 to 99	20 s
Cooling control period (see notes 1 and 3)	1	6	Yes	Yes	Yes	No	1 to 99 s	0001 to 99	20 s
Hysteresis (see note 2)	1	8	Yes	Yes	Yes	Yes	0.0 to 999.9°C	0000 to 9999	0.8°C
Alarm hysteresis (see note 4)	1	9	Yes	Yes	Yes	No	0.0 to 999.9°C	0000 to 9999	0.2°C
Heater current monitor (see note 3)	1	A	No	Yes	Yes	No	0.0 to 55.0 A	0000 to 0550	0.0 A
Heater burnout current (see note 3)	1	B	Yes	Yes	Yes	No	0.0 to 50.0 A	0000 to 0050	0.0 A
							0.0: No heater burnout detection, alarm signal OFF 50.0: No heater burnout detection, alarm signal ON		
Heating control output variable monitor	2	0	No	Yes	Yes	No	0.0 to 100.0%	0000 to 1000	0.0%
Cooling control output variable monitor	2	6	No	Yes	Yes	No	0.0 to 100.0%	0000 to 1000	0.0%
Auto-tuning start/stop (see note 1)	2	1	Yes	No	Yes	No	---	Start = 0001 Stop = 0000	---
Copy bank	2	2	Yes	No	Yes	No	---	0001	---
Input-type monitor	2	3	No	Yes	No	No	0 to 9	0000 to 0009	Setting for SW202

Parameter	Com-mand		Write	Read	Loop no.	Bank no.	Actual data range	Write/Read data range	Default value
Alarm 1 mode	2	4	Yes	Yes	Yes	No	0 to 9	0000 to 0009	2
Alarm 2 mode	2	5							

Yes: Possible.

No: Not possible or not required.

- Note**
1. Only when advanced PID control is selected. (switch 203-1 = OFF)
 2. Only when ON/OFF control is selected. (switch 203-1 = ON)
 3. Invalid only for C200H-TV 03 (current output type).
 4. Does not apply when Alarm Mode = 0.
 5. Thermocouple = TC
Platinum Resistance Thermometer = Pt

4-2 Data Flow

Refer to 3-2 Data Flow for the data flow in the Heat/Cool Temperature Control Unit.

Data Settings

Before setting data with a user program or the Programming Console, turn ON SW2-2 of the Unit to enable data setting from the C200H PC. However, the executed bank number can be set with a user program or from the Programming Console regardless of the ON/OFF setting of SW2-2.

SW2-1 (switching memory contents) may be set in either the OFF (Fixed) or ON (Normal) position, but care is required as the setting of this switch changes the stored data contents.

4-3 Programming

4-3-1 Example with SW2-1 in the Fixed Position

Description and Conditions

<p>Example: The user program makes the following settings: Loop 1 SP = 80°C Loop 2 SP = 200°C Loop 1 executed bank number = 1 Loop 2 executed bank number = 3</p>
<p>Conditions: C200H-TV001 (thermocouple) SW203 set to 2 (K). Unit number set to 0 (allocated memory: IR100 to IR109). SW2-1 set OFF (Fixed) and SW2-2 set ON (C200H PC).</p>

Sample Program

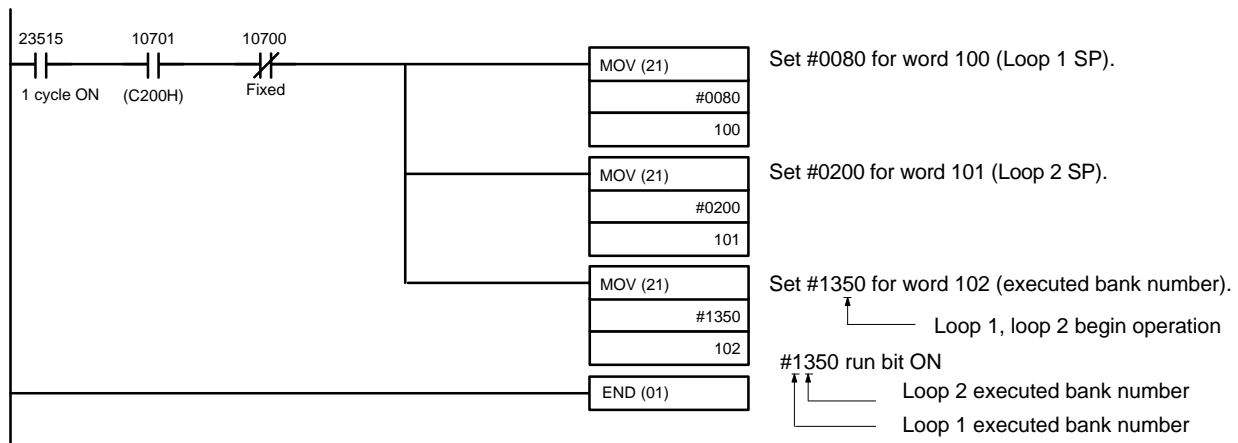

Be sure to set the correct values for the Loop 1 and Loop 2 SP.

The SV value is #0000 (0°C) if no data is set. If the executed bank number is set to a value out of the range from 1 to 8 the bank number reverts to the previous value (default value = 1).

Reading Monitored Data Read monitored data into the program using Wd (n+3) to (n+9).

4-3-2 Example 1: Write with SW2-1 in the Normal Position

Description and Conditions

Example	<p>The user program makes the following settings:</p> <p>Loop 1 SP = 200°C (Bank no. = 1) Loop 2 SP = 250°C (Bank no. = 2) Loop 1 executed bank number = 1 Loop 2 executed bank number = 2 Loop 1 heater burnout current value = 2.0 A Loop 2 heater burnout current value = 2.5 A</p>
Conditions	<p>C200H-TV001 (thermocouple) SW203 set to 2 (K). Unit number set to 0 (allocated memory: IR100 to IR109). SW2-1 set ON (Normal) and SW2-2 set ON (C200H PC).</p>

Sample Program

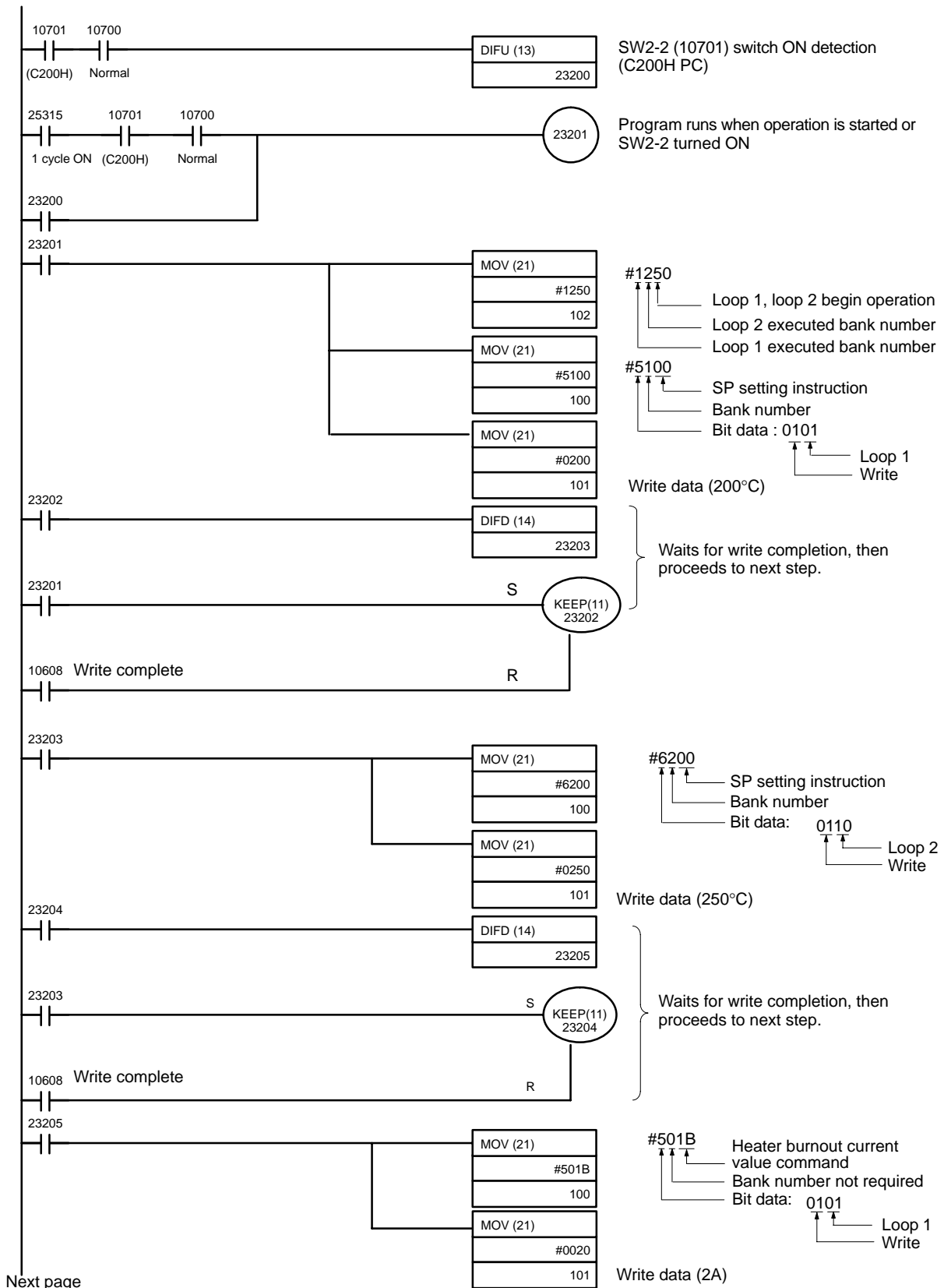

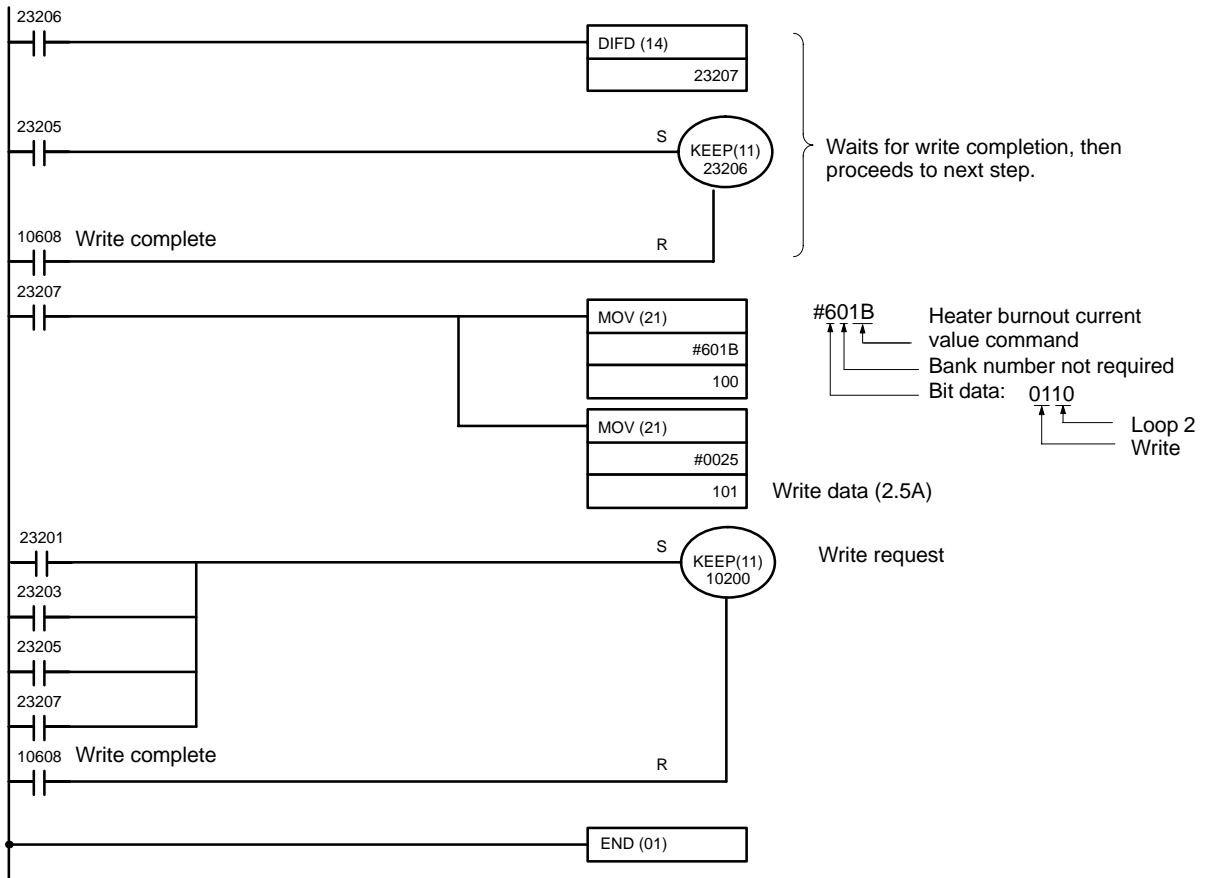

Timing Chart

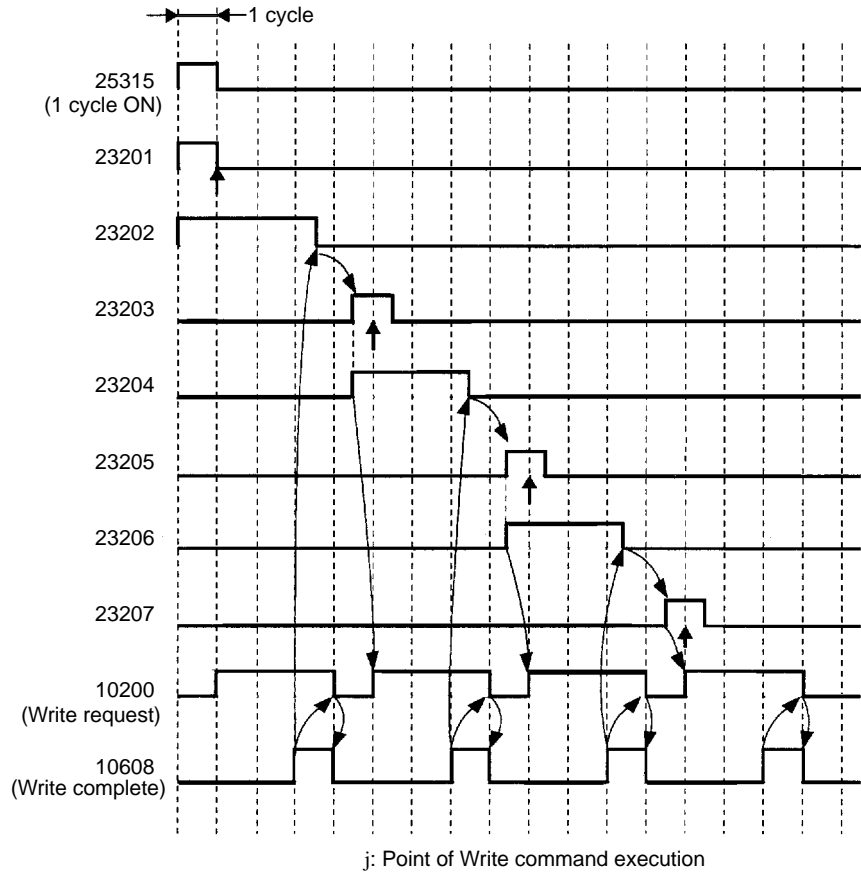

In addition to the timing above, 23201 turns ON for one cycle on the ON rising edge of SW2-2 (10701).

4-3-3 Example 2: Read with SW2-1 in the Normal Position

Description and Conditions

<p>Example: The following data is read from the indicated addresses: Loop 1 PV: DM0000 Loop 1 heating control output variable: DM0001 Loop 2 heater current: DM0002 This read program is to be executed after writing the data with program example 1.</p>
<p>Conditions: C200H-TV001 (thermocouple) SW203 set to 2 (K). Unit number set to 0 (allocated memory: IR100 to IR109. SW2-1 set ON (Normal) and SW2-2 set ON (C200H PC).</p>

Sample Program

Insert the program below before the END instruction in the program on page 46.

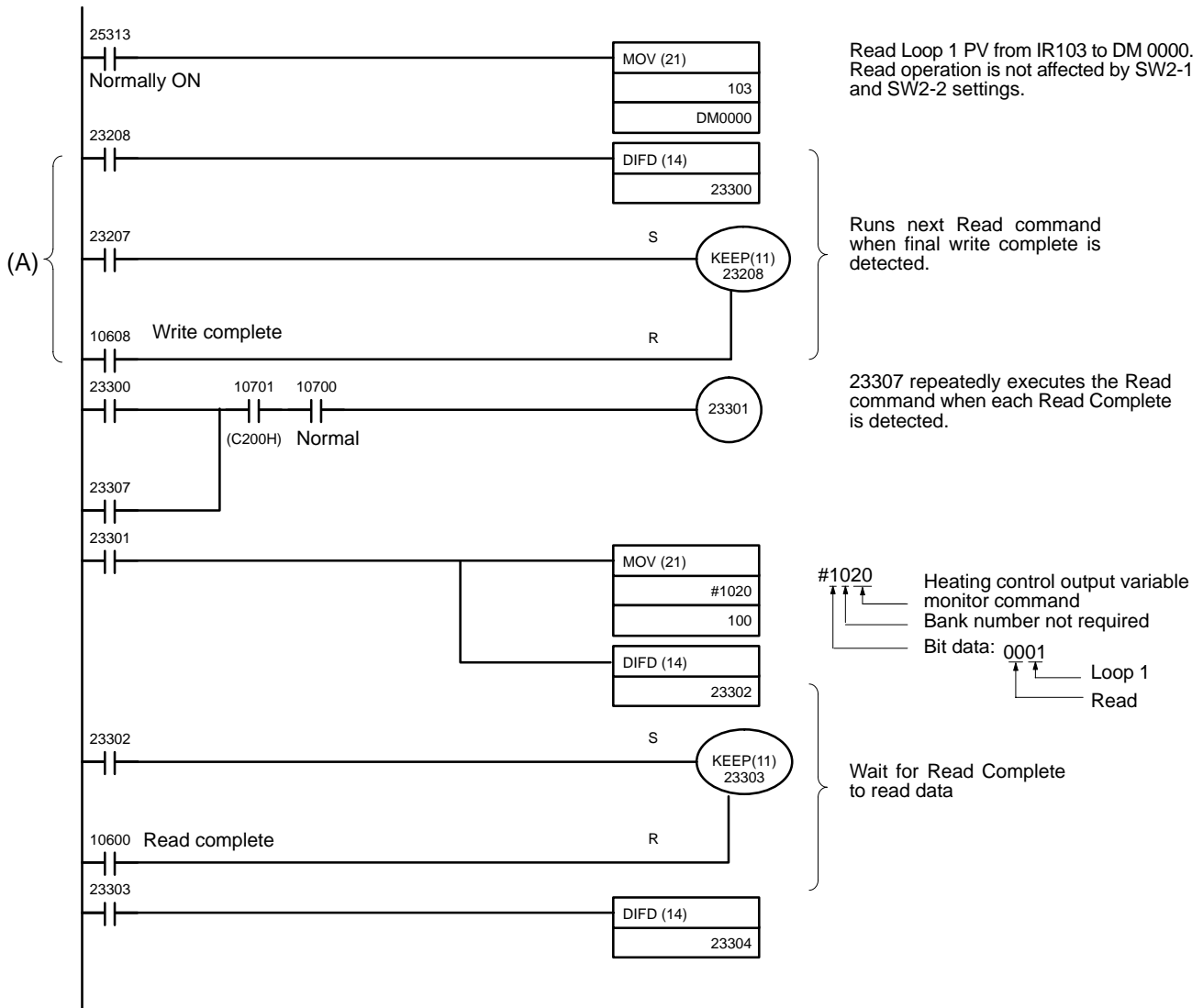

Next page

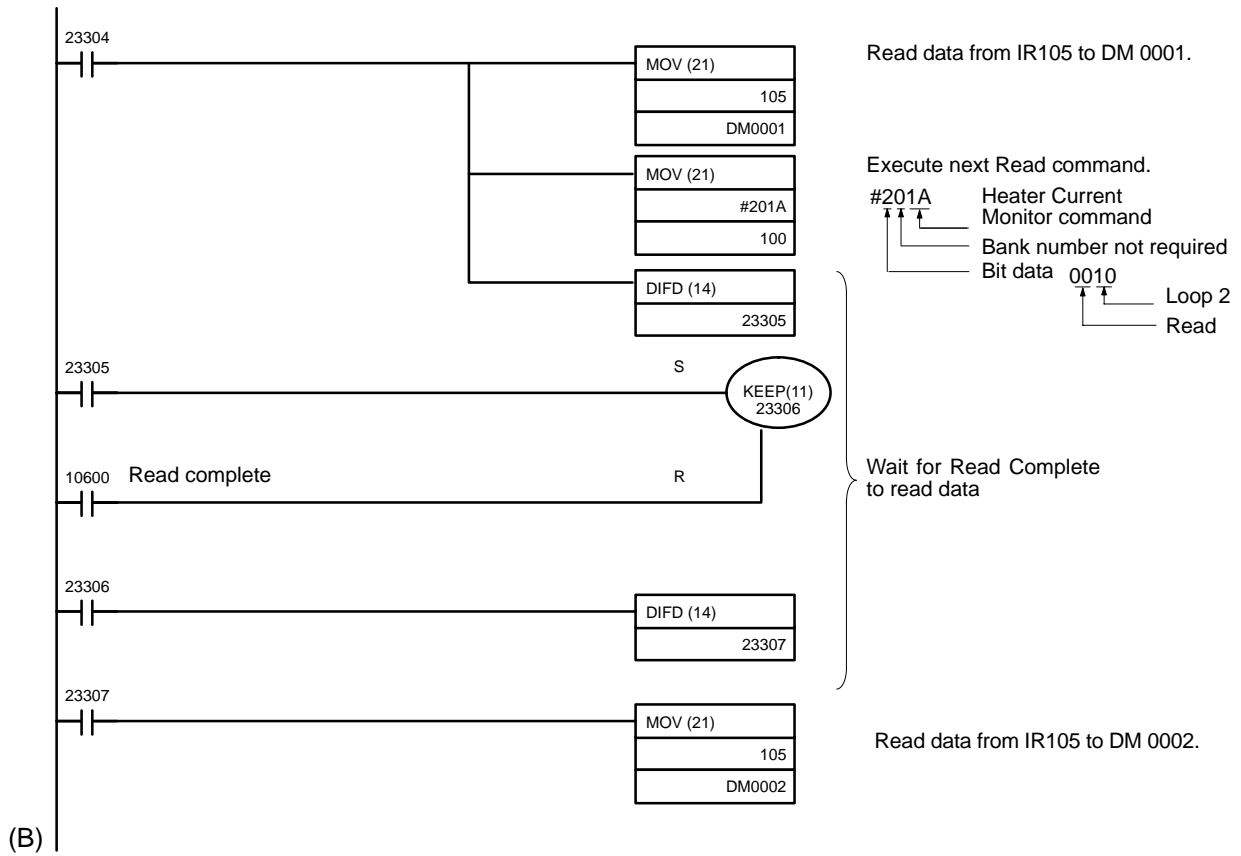

Change the above program as shown below if only reading is to be carried out. Replace part (A) of the program with the following program.

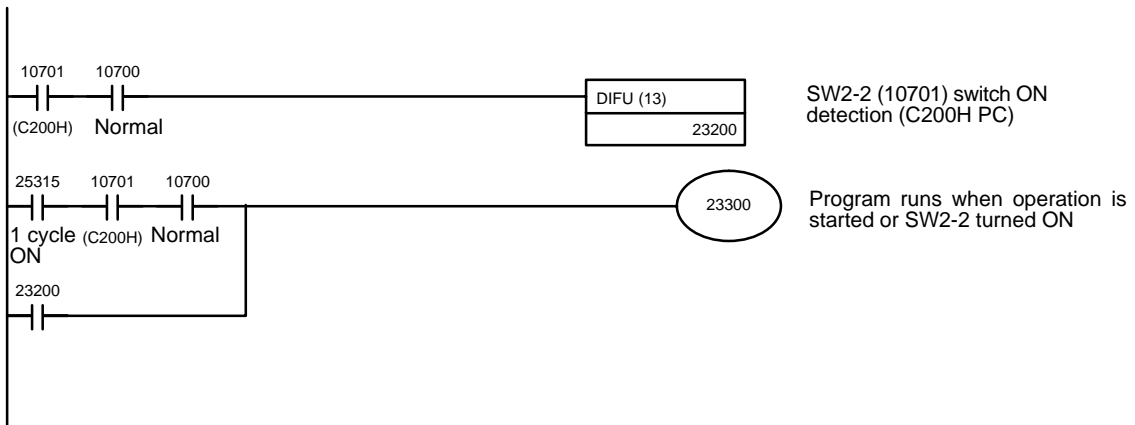

Add an END instruction (01) at position (B) of the program.

Timing Chart

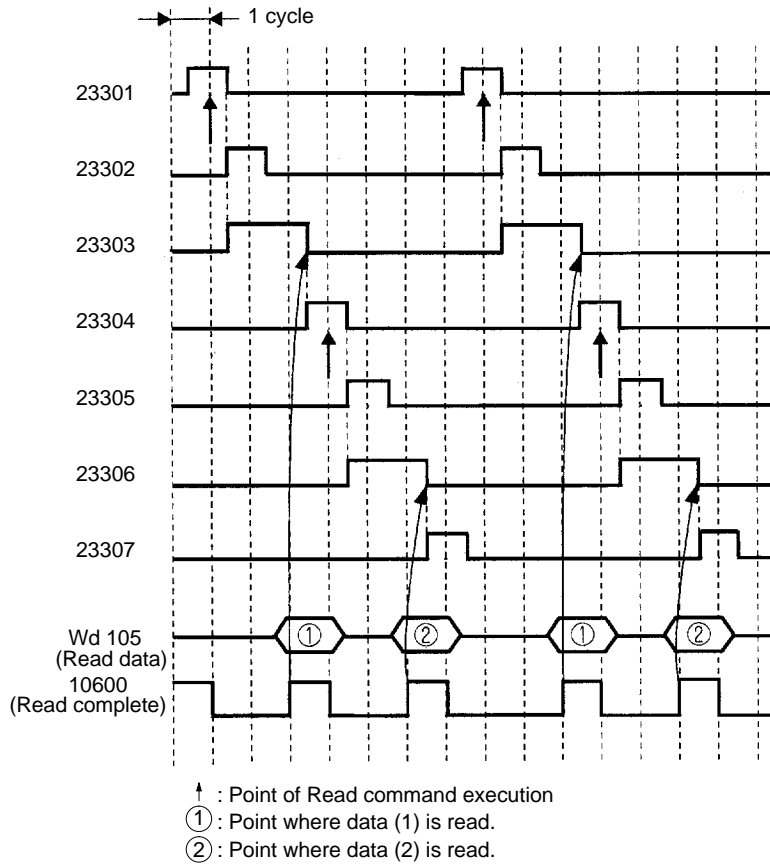

4-3-4 Operation Timing

Write Operation Timing

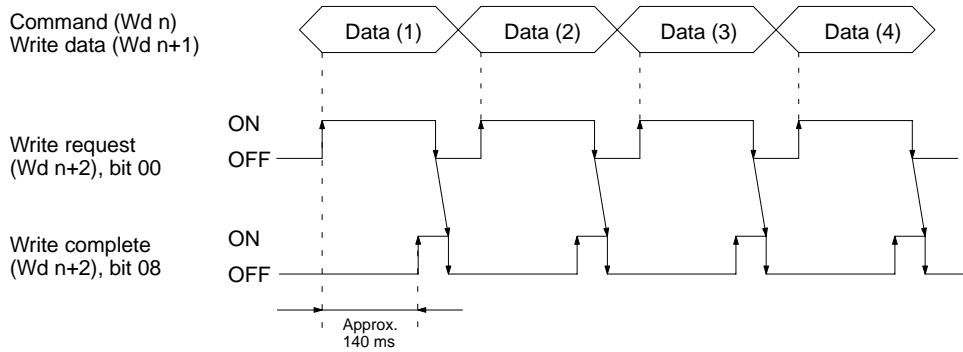

- 1, 2, 3...**
1. The data is written to the Heat/Cool Temperature Control Unit EEPROM when the Write Request Flag turns ON.
 2. The Write Complete Flag turns ON when the data writing operation is completed. It takes approximately 140 ms to write the data.
 3. The Write Complete Flag automatically turns OFF when the Write Request Flag turns OFF.

Check the Write Complete Flag is ON before turning OFF the Write Request Flag. If the Write Request Flag is set to OFF before the Write Complete Flag turns ON the Write Complete Flag will not subsequently turn ON.

Temporarily turn the Write Request Flag OFF before executing the second and subsequent write operations. Writing is enabled on the ON rising edge of the Write Request Flag.

The Loop 1 and 2 executed bank number (Wd n+2) sets data directly. The data is written to the Heat/Cool Temperature Control Unit RAM. If the value is set out of this range, the bank number reverts to the previous value (default value = 1).

Timing for a Read Operation

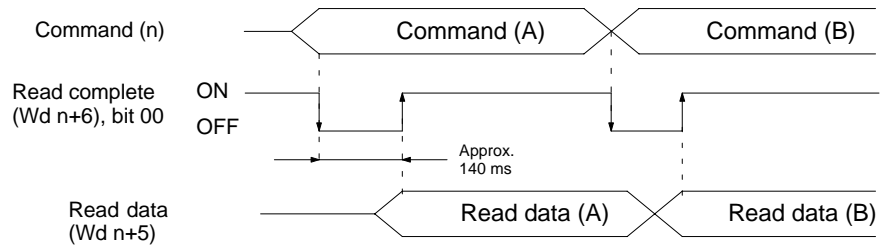

- 1, 2, 3...**
1. The read data is output to Wd (n+5) approximately 140 ms after the Read command is executed.
 2. The read data is updated every 100 ms.
 3. When the Read command is modified, turn OFF the Read Complete Flag to execute the next read operation.

I/O Refresh

Heating and cooling control will not be executed properly unless there are at least 8 ms between I/O refresh operations. When creating the program, be sure that all of the conditions described below are satisfied.

- The cycle time must be a minimum of 8 ms. If the program processing time is short, it is recommended that the fixed cycle time instruction, SCAN(18), be used.
- When IORF(97) is executed for the Temperature Control Unit, there must be an interval of at least 8 ms between prior and subsequent end refreshes.
- The time interval for executing IORF(97) must be a minimum of 8 ms.

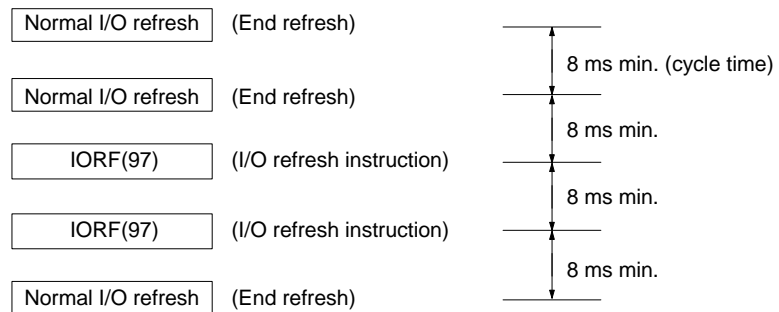

SECTION 5

Troubleshooting

This section provides possible errors and error remedies.

Error Detection	54
-----------------------	----

Error Detection

When an error occurs in an input or in the Unit, details of the error are output to the Data Setting Console and input relays (words n+8 and n+9).

Sensor Input Errors

The following table shows the Data Setting Console display and error contents.

Display	Error name	Output status after error	Cause	Remedy
<i>SEr1</i>	Loop 1 sensor error	Control output: The transistor output or voltage output turns OFF or the current output falls below 2 mA. Alarm output: The alarm is output assuming the input is +10%FS.	Reading is + 10%FS out of sensor measurement range (i.e., 10%FS below the lower limit or 10%FS above the upper limit). Broken or incorrect input wiring Defective input sensor Defective Unit SW203-4 is OFF (Loop 2 enabled) but no sensor connected to Loop 2	Check the sensor wiring. Replace the sensor. Replace the Unit. Correctly set switch SW203-4.
<i>SEr2</i>	Loop 2 sensor error			
<i>SErr</i>	Cold junction compensating circuit error (C200H-TC00)	Control output: The transistor output or voltage output turns OFF or the current output falls below 2 mA.	Abnormality in cold junction compensating circuit.	Replace the Unit.

Data Setting Console

When a sensor error occurs, one of the codes above and the detected temperature are displayed alternately.

If a Loop 1 sensor error *ser1* and a Loop 2 sensor error *ser2* occur simultaneously, *ser1* is displayed preferentially. Even if a sensor error is detected in one Loop, the other Loop continues to operate normally. Control operation restarts automatically five seconds after the cause of the error is corrected. If a cold junction compensating circuit error occurs, reset the power supply.

The following bits are set when a sensor input error occurs.

Loop 1 sensor error	Wd. n+8, bit 14 = 1; Wd. n+9, bit 14 = 0
Loop 2 sensor error	Wd. n+8, bit 14 = 0; Wd. n+9, bit 14 = 1
Cold junction compensating circuit error	Wd. n+8, bit 14 = 1; Wd. n+9, bit 14 = 1

CT Input Overflow

Display	Error name	Cause	Remedy
<i>EE</i> <i>FFFF</i>	CT input overflow	The detected heater current exceeds 55.0 A.	Check the CT and heater wiring.

The information is displayed as heater current monitor data. It cannot be checked while other parameter data is being displayed. The display returns to normal after the cause of the error is removed.

The following bits are set when a CT overflow error occurs.

Wd (n+8), bit 13 = 1	Loop 1 CT overflow
Wd (n+9), bit 13 = 1	Loop 2 CT overflow

Heater Burnout Alarm

Display	Error name	Cause	Remedy
HB indicator lit	Heater burnout	The detected heater current is below the heater burnout current value.	Check the heater and heater wiring. Replace heater if necessary.

Error displayed when an abnormality occurs in the loop currently being displayed.

The following bits are set when a heater burnout alarm occurs.

Wd (n+8), bit 02 = 1	Loop 1 heater burnout alarm
Wd (n+9), bit 02 = 1	Loop 2 heater burnout alarm

Use one of the methods below to reset a heater burnout alarm.

- a) Turn the Special I/O Unit restart flag (AR0100 to AR0109) ON and then back OFF.
- b) Turn the C200H power supply OFF then back ON.
- c) Set the heater burnout current limit to 00 then back to its original value.

Temperature Alarm

Display	Error name	Cause	Remedy
ALM1 indicator lit	Temperature alarm 1	The temperature is in the alarm range set with Alarm 1 SV.	Check the controlled conditions
—	Temperature alarm 2	The temperature is in the alarm range set with Alarm 2 SV.	

“ALM1” displays the temperature alarm 1 for the loop current selected. No indicator is provided to show an ALM2 alarm.

The bits shown in the table below are set to 1 when a temperature alarm occurs.

Wd (n+8)	Bit 01 =1	Temperature alarm 1	Loop 1
	Bit 00 =1	Temperature alarm 2	
Wd (n+9)	Bit 01 =1	Temperature alarm 1	Loop 2
	Bit 00 =1	Temperature alarm 2	

EEPROM Error

Display	Error name	Output status after error	Cause	Remedy
E III	EEPROM error	Control output: The transistor output or voltage output is OFF or the current output is less than 2 mA. Alarm output is OFF.	Defective EEPROM	Replace the Unit

The RUN indicator turns off when an EEPROM error occurs.

Duplicate I/O Unit

The Unit number duplicates the number of another Special I/O Unit. The SR bit 25415 turns ON when an Duplicate I/O Unit error occurs. Refer to AR0000 to AR0011 for the duplicated Unit number. The C200H PC will not operate during a duplicate I/O error.

Set the Unit number to a separate number.

Special I/O Unit Error

I/O refresh not operating correctly between the CPU Unit and Temperature Control Unit. The Heat/Cool Temperature Control Unit is operating based on the con-

tents of the previous refresh. Refer to AR0000 to AR0015 for the Unit number where the error occurred. After correcting the cause of the error, set the Special I/O Unit Restart Flag (AR0100 to AR0109) to restart operation.

RUN Indicator Unlit

The C200H power supply is turned on but the RUN indicator is not lit. None of the errors described previously are detected. Replace the Unit.

No Data Setting Console Display

- No 24 VDC power supply is connected to the Heat/Cool Temperature Control Unit input terminals A8 and A9.
- The connecting cable is disconnected.
- The connecting cable is broken.
- A circuit in the Data Setting Console is defective.
- A circuit in the Heat/Cool Temperature Control Unit is defective.

After determining the cause of the error, correct the problem or replace the Unit.

Appendix A Specifications

General Specifications

Conforms to the C200H PC specifications.

Item	C200H-TV00	C200H-TV10
Connectable temperature sensor (see note 1)	Thermocouple (R, S, K, J, T, E, B, N, L, U)	Platinum resistance thermometer (JPt100, Pt100)
Current Transformer detection current	0.1 to 49.9 A (with a heater burnout detecting current difference of 2.5 A min.) Indication accuracy: $\pm 5\%$ FS ± 1 digit max.	
No. of input points (loops)	Two points (two loops, each of which consists of a temperature sensor and a CT)	
Temperature control mode	PID, ON/OFF (selectable with a switch on the rear panel) (advanced PID control with auto-tuning)	
Setting/designation accuracy (See notes 2 and 3.)	$\pm 0.5\%$ of set (designated) value or $\pm 2^{\circ}\text{C}$ (whichever is larger) ± 1 digit max.	$\pm 0.5\%$ of set (designated) value or $\pm 1^{\circ}\text{C}$ (whichever is larger) ± 1 digit max.
Hysteresis	0.0 to 999.9 $^{\circ}\text{C}/^{\circ}\text{F}$ (in units of 0.1 $^{\circ}\text{C}/^{\circ}\text{F}$) (during ON/OFF control action)	
Proportional band	0.0 to 999.9 $^{\circ}\text{C}/^{\circ}\text{F}$ (in units of 0.1 $^{\circ}\text{C}/^{\circ}\text{F}$)	
Integral (reset) time	0 to 9999 s (in units of 1 s)	
Derivative (rate) time	0 to 9999 s (in units of 1 s)	
Control period	1 to 99 s (in units of 1 s)	
Sampling period	500 ms	
Output refresh period	500 ms	
Display refresh period	500 ms	
Input shift range	-99.9 to 999.9 $^{\circ}\text{C}/^{\circ}\text{F}$ (in units of 0.1 $^{\circ}\text{C}/^{\circ}\text{F}$)	
Alarm output setting range	-999 to 9,999 $^{\circ}\text{C}/^{\circ}\text{F}$ (in units of 1 $^{\circ}\text{C}/^{\circ}\text{F}$)	-99.9 to 999.9 $^{\circ}\text{C}/^{\circ}\text{F}$ (in units of 0.1 $^{\circ}\text{C}/^{\circ}\text{F}$)
No. of banks	8 banks	
Internal current consumption	5 VDC, 0.33 A max.	
External supply voltage	24 VDC $+10\%/-15\%$, 0.2 A min.	
Dimensions (see note 4)	34.5 mm (W) x 130 mm (H) x 120.5 mm (D)	
Weight	360 g	

- Note**
1. Set with the switch on the rear panel. See *Appendix B Sensor Temperature Measurement Range* for the measurable temperature range.
 2. The set value and designated value coincide with each other.
 3. The indication accuracy of thermocouples R and S at a temperature of 200 $^{\circ}\text{C}$ max., that of thermocouples K and T at a temperature of -100 $^{\circ}\text{C}$ max, and that of thermocouple U are all $\pm 4^{\circ}\text{C}$, ± 1 digit max. The indication accuracy of thermocouple B at a temperature of 400 $^{\circ}\text{C}$ or below is not guaranteed.
 4. See *Appendix D Dimensions*.

Output Characteristics

Transistor Output (Pulse) C200H-TV 01

External supply voltage	24 VDC +10%/−15%
Max. load voltage	24 VDC (collector supplied voltage) max.
Max. load current	100 mA max.
Residual voltage when ON	3 V max.
Leakage current when OFF	0.3 mA max.

Voltage Output (Pulse) C200H-TV 02

Output voltage	12 VDC
Max. load current	40 mA (with short-protective circuit)

Current Output (Linear) C200H-TV 03

Output current	4 to 20 mA
Permissible load impedance	600 Ω max.
Current value accuracy	4±0.3 to 20±1 mA

Appendix B

Sensor Temperature Measurement Ranges

C200H-TV00 Thermocouple

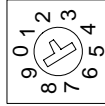

Set the thermocouple type with the switch on the rear panel.

This switch is factory-set to 2 (K).

The Data Setting Console can display the range from 10%FS below the lower limit to 10%FS above the upper limit.

Input		R Platinum vs. platinum rhodium 13%	S Platinum vs. platinum rhodium 10%	K (CA) Chromel vs. alumel	J/L (IC) Iron vs. constantan	T/U (CC) Copper vs. constantan	E (CRC) Chromel vs. constantan	B Platinum rhodium 30% vs. platinum rhodium 6%	N Nichrosil vs. nilsil
Range	°C	0 to 1,700	0 to 1,700	-200 to 1,300	-100 to 850	-200 to 400	0 to 600	100 to 1,800	0 to 1,300
	°F	0 to 3,000	0 to 3,000	-300 to 2,300	-100 to 1,500	-300 to 700	0 to 1,100	300 to 3,200	0 to 2,300
Switch setting		0	1	2	3/8	4/9	5	6	7

C200H-TV10 Platinum Resistance Thermometer

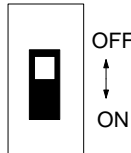

Set the platinum resistance thermometer type with the switch on the rear panel.

This switch is factory-set to OFF (JPt100).

The Data Setting Console can display the range from 10%FS below the lower limit to 10%FS above the upper limit.

Input		JPt100	Pt100
Range	°C	-99.9 to 450.0	-99.9 to 450.0
	°F	-99.9 to 800.0	-99.9 to 800.0
Switch setting		OFF	ON

Appendix C

Heater Burnout Detection

Heater Burnout Detection System

The heater wiring is connected through the Current Transformer (CT). As a current flows through the heater wiring, an alternating current is induced in the CT which is dependent on the size of the current flowing. This induced current drops to zero if the heater burns out. The heater burnout alarm signal is output when the induced current is compared to the set current value.

Heater Burnout Alarm Precautions

- Turn on the heater power supply and the input terminal 24-VDC power supply at the same time as or before the C200H PC power supply. The heater burnout signal is output if the heater power supply or the input terminal 24-VDC power supply is turned on after the C200H PC power supply.
- Temperature Control Unit operation continues if a burned-out heater causes a heater burnout alarm. Control signal output continues according to the control parameters. Take measures to detect the heater burnout alarm signal to allow early repair.
- The heater burnout alarm is output when the control output is ON. Once the heater burnout alarm is output, it remains ON. Use one of the methods below to reset a heater burnout alarm.
 1. Turn the Special I/O Unit Restart Flag (AR0100 to AR0109) ON and then back OFF.
 2. Turn the C200H PC power supply OFF then back ON.
 3. Set the heater burnout current limit to 0.0 then back to its original value.
- Make sure that the current difference between normal operation and heater burnout is at least 2.5 A. Stable detection is difficult with a current difference less than 2.5 A.
- Heater burnout detection is not possible with the current output type (C200H-TV 03) or with 3-phase heaters.
- Set the heater burnout current to 0.0 when heater burnout detection is not required because the CT input wiring is not detected.

Determining the Heater Burnout Detection Current

- Determine the SV from the following equation:
$$SV = \frac{\text{Normal current value} + \text{heater burnout current}}{2}$$
- If more than one heater is connected through the CT, take the heater burnout current as the value when the heater with the smallest current consumption is burned out. If all heaters consume equal current, take the heater burnout current as the value when any one heater is burned out.
- Make sure that the current difference between normal operation and heater burnout is at least 2.5 A. Stable detection is difficult with a current difference less than 2.5 A.
- Set the SV in the range between 0.1 A and 49.9 A. Heater burnout detection is not carried out if the SV is set to 0.0 A or 50.0 A. The alarm signal is always OFF if the SV is set to 0.0 or always ON if the SV is set to 50.0.
- The total heater current during normal operation should not exceed 50 A. If the current exceeds 55.0 A, a CT Input Overflow error occurs and *FFFF* is displayed if the heater current monitor is selected.

Measure each current with the heater current monitor. In some cases the calculated current may differ from the actual measured value.

Sample SV Calculations

Example 1

Using one 200 VAC, 1 kW heater

$$\text{Normal current} = \frac{1000}{200} = 5 \text{ A}$$

Burnout current = 0 A

$$\text{SV} = \frac{5+0}{2} = 2.5 \text{ A} (\leq 49.9 \text{ A})$$

Example 2

Using three 200 VAC, 1 kW heaters

$$\text{Normal current} = \frac{1000}{200} \times 3 = 15 \text{ A}$$

$$\text{Burnout current with one heater burned out} = \frac{1000}{200} \times 2 = 10 \text{ A}$$

$$\text{SV} = \frac{15+10}{2} = 12.5 \text{ A} (\leq 49.9 \text{ A})$$

Difference between normal and burnout current = 15 – 10 = 5 A (≥ 2.5 A)

Specifications

Heater Burnout Detection Characteristics

Heater burnout detection setting range	0.1 to 49.9 A (in units of 0.1 A) (see note 1)
Current difference required for heater burnout detection	2.5 A min. (normal time – burnout time)
Heater current monitor range	0.0 to 55.0 A
Monitor accuracy of input current	+5% of FS +1 digit max.
Min. detectable ON time	200 ms (see note 2)

- Note**
1. If the heater burnout detection setting value is set to 0.0 or 50.0 A, no heater burnout detection is possible. The alarm signal is turned OFF if the heater burnout detection setting value is set to 0.0 A and turned ON if it is set to 50.0 A.
 2. If the heating control output is turned ON for less than 200 ms, no heater burnout detection or heater current measurement is possible.

E54-CT1/CT3 Current Transformer

Max. continuous heater current	50 A
Dielectric strength	1,000 VAC (1 min)
Vibration resistance	50 Hz (approx. 10G)
Weight	E54-CT1: approx. 11.5 g; E54-CT3: approx. 50 g
Accessories (E54-CT3 only)	Contact: 2; Plug: 2

Current Transformer Dimensions

E54-CT1

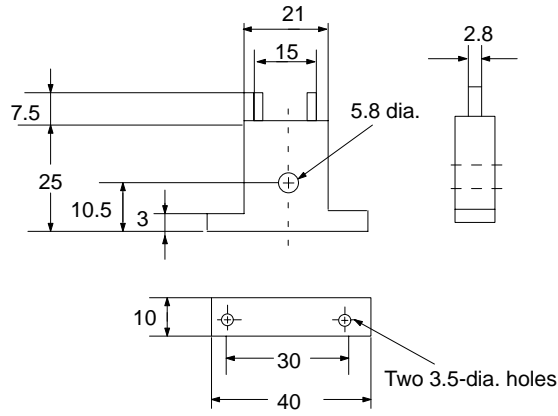
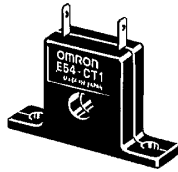

E54-CT3

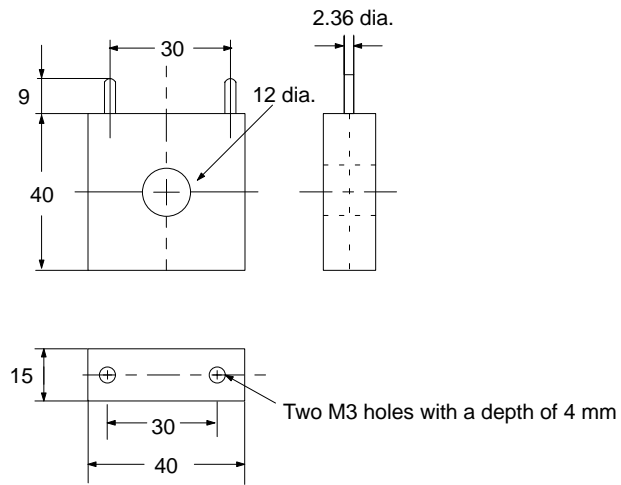

Current Transformer Circuit Diagram

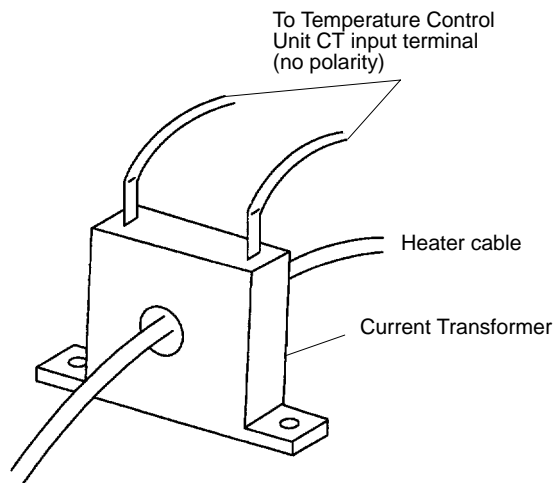
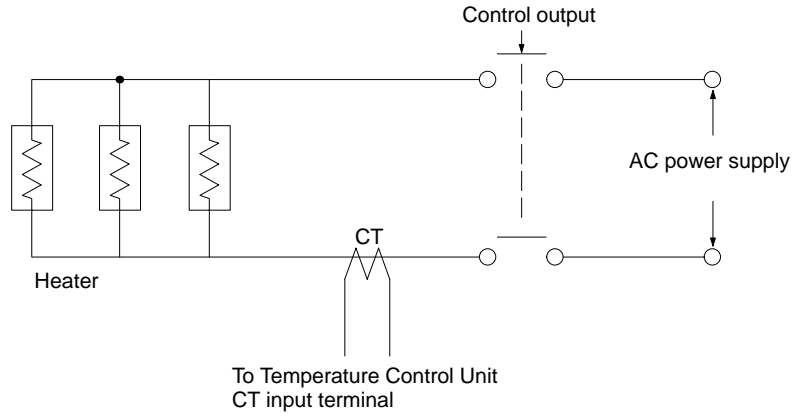

Appendix D Dimensions

Heat/Cool Temperature Control Unit

Unit Dimensions

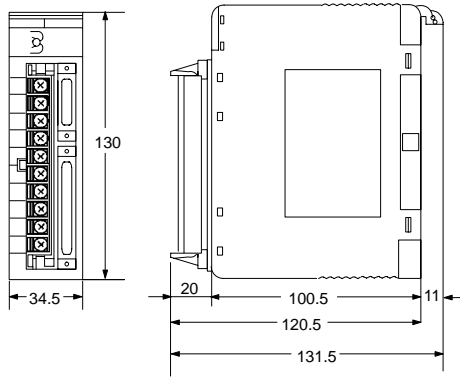

Mounting Dimensions

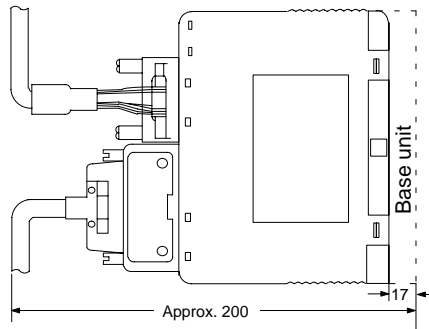

Weight: 360 g

Data Setting Console

Unit Dimensions

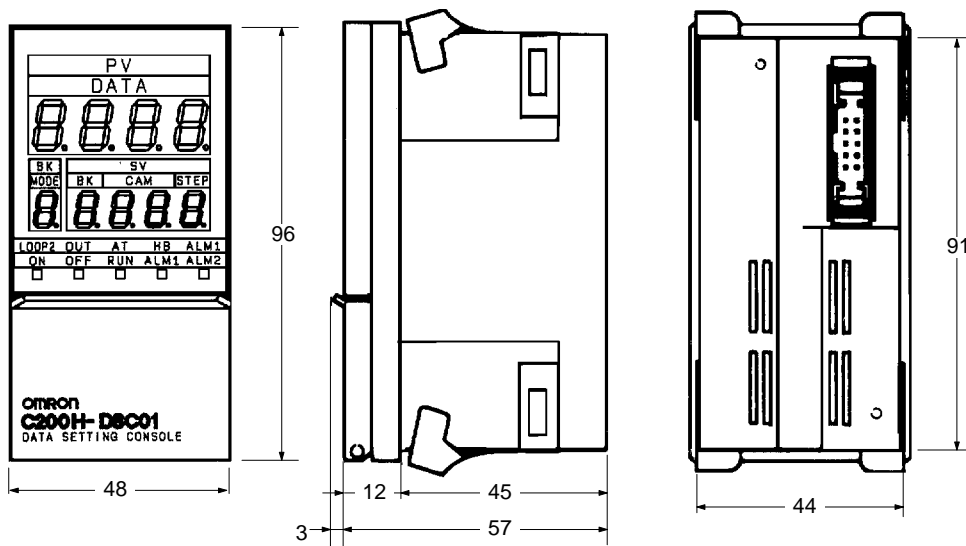

Weight: 120 g

Mounting Dimensions

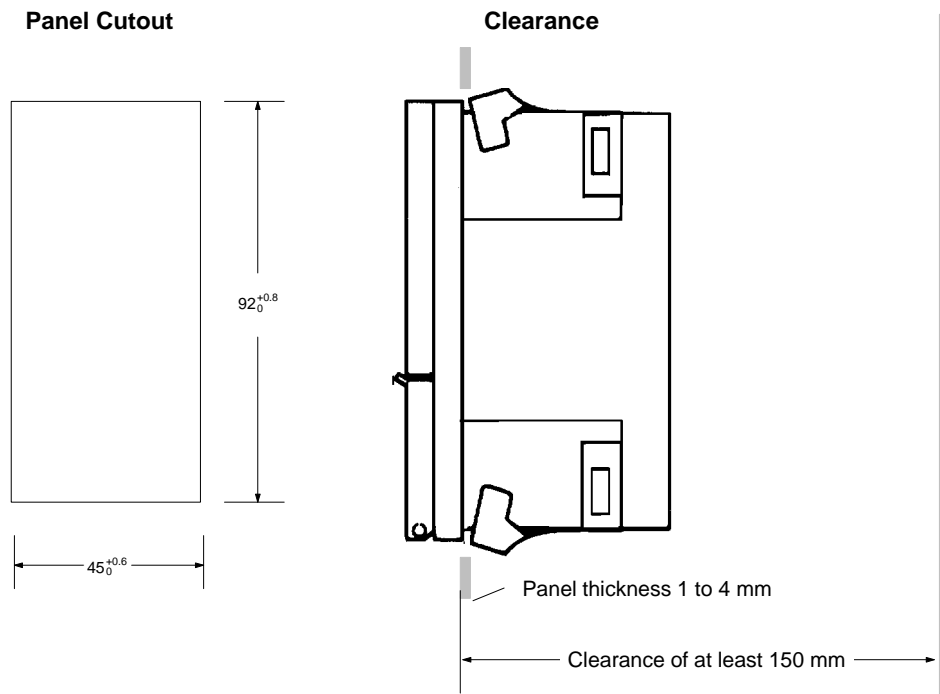

Allow a clearance of at least 150 mm behind the Data Setting Console when it is installed in the panel to allow cable connectors to be inserted. A clearance of 50 mm is sufficient if the rear panel can be opened.

Appendix E

Parameters and Key Operations

The Data Setting Console key operations and their relation to parameters are shown in the following table.

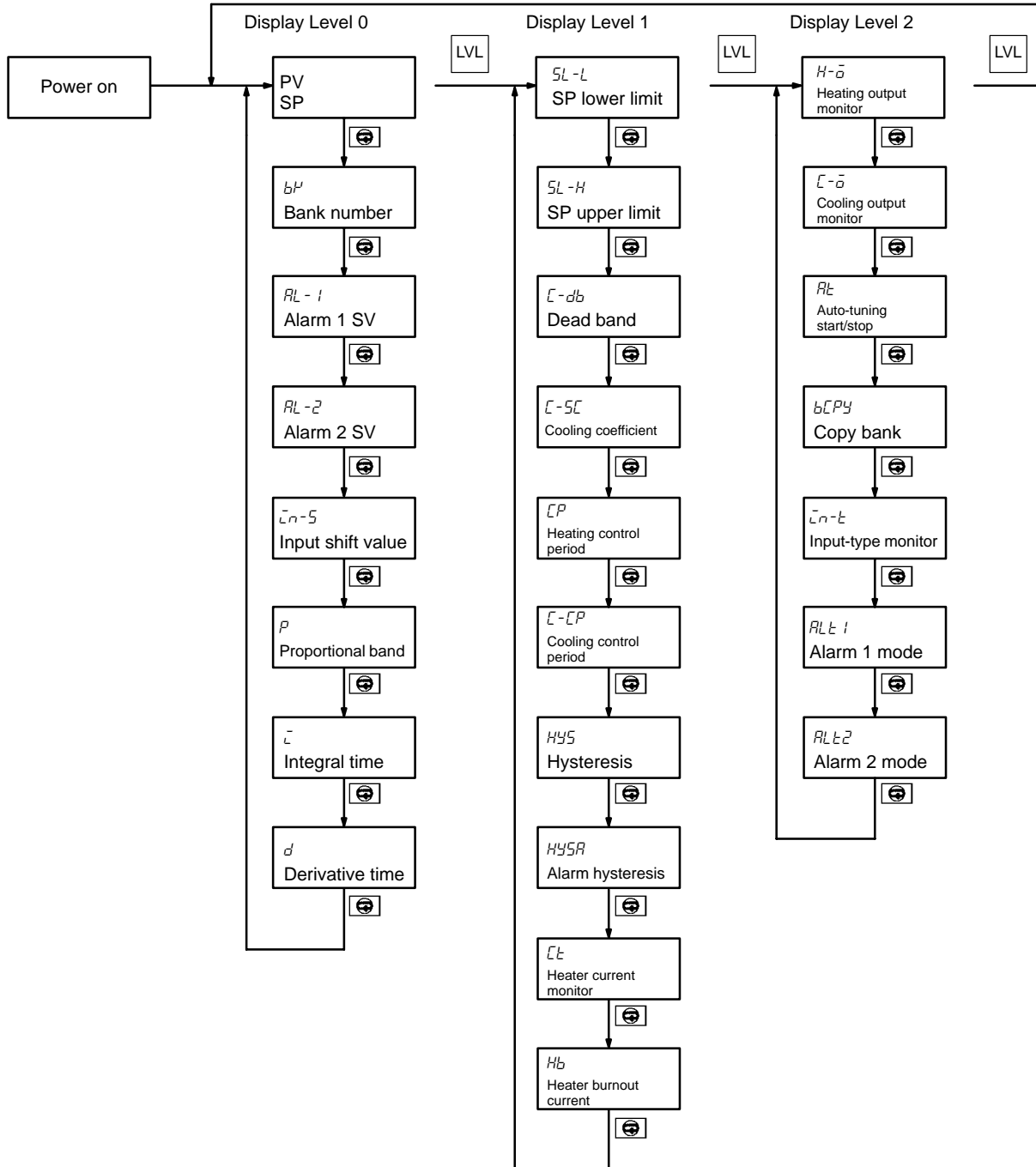

Index

A-B

advanced PID control, 2
alarm hysteresis setting, 30
alarm mode setting. *See* settings
alarm SV 1 setting, 27
alarm SV 2 setting, 27
allocating memory, 36
auto-tuning start/stop setting, 31
See also settings
bank number setting, 26

C

command codes, settings, 41
compensating conductors, specifications, 12
connections, 12
Connector Terminal Block Converter Unit, 16
control output variable monitor setting, 31
See also settings
control period setting, 29
cooling coefficient setting, 29
copy bank setting. *See* settings
cover, removal and replacement, 8
CT input overflow error, 54
Current Transformer, 13

D

data flow, 21
data setting, 21
 operating procedure, 20
Data Setting Console
 connecting cable and precautions, 17
 features, 23
 mounting, 66
 parameter and setting tables, 24
 physical features, 22
data settings, 43
dead band setting, 28
derivative time setting, 27
detecting errors, 54
Duplicate I/O Unit, 55

E-H

EEPROM error alarm, 55
error display, 26
errors, data setting, 54
features, 2
function setting, 9
Heater Burnout Alarm, 55
heater burnout current setting. *See* settings
heater burnout detection, precautions and current ranges, 61
heater current monitor, 30
hysteresis setting, 29

I

I/O refresh, 51
indicators, 7, 23
input shift value setting, 27
input wiring
 Platinum Resistance Thermometer, 11, 13
 precautions, 11
 thermocouple, 10
input-type monitor. *See* settings
integral time setting, 27

K-M

key operations, 67
memory contents, 38

O

operation setting, 9
operation timing, 50
output wiring, 13
 circuit diagrams, 14
 connection diagrams, 13
 connectors and cable, 15
 diagrams, 15
 precautions, 15

P

parameters, 67
precautions, 4
programming, examples, 43, 44, 47

proportional band setting, 27

PV setting, 26

R-S

read operation timing, 51

Remote I/O Terminal, 16

selecting allocated memory, 36

sensor-type setting, 31

sensors, setting type, 8

setting and displaying parameters, method, 26

settings, source, 8

Slave Rack, number of mountable Units, 4

SP lower limit setting, 28

SP upper limit setting, 28

Special I/O Unit error, 55

specifications, general, table, 57

SV setting, 26

switch settings, 7

switching memory contents, 8

switching memory contents and setting direction, 7

system configuration, 3

T-U

temperature alarm, 55

temperature measurements, ranges, 59

troubleshooting

CT input overflow, 54

data setting errors, 54

duplicate I/O unit, 55

EEPROM error, 55

Heater Burnout Alarm, 55

power supply, 56

RUN Indicator Unlit, 56

Special I/O Unit error, 55

temperature alarm, 55

Unit, models, 3

Unit components, dimensions, 65

Unit nomenclature, 6

Revision History

C200H-TV□□□ Heat/Cool Temperature Control Unit

Operation Manual

A manual revision code appears as a suffix to the catalog number on the front cover of the manual.

Cat. No. W240-E3-1

↑
Revision
code

The following table outlines the changes made to the manual during each revision.

Revision code	Date	Revised content
W240-E1-1	November 1993	Original production
W240-E3-1	February 1998	Page 15: Table added to Section 2-3 Page 42: Write/Read data range correction in Heating and Cooling Control Period rows in the Table of Commands.