

THIS DRAWING IS UNPUBLISHED. RELEASED FOR PUBLICATION
 © COPYRIGHT 20 BY - ALL RIGHTS RESERVED.

REVISIONS				
P	LTR	DESCRIPTION	DATE	APVD
	F1	REVISED PER ECR-16-011494	21JUN2017	NK CX

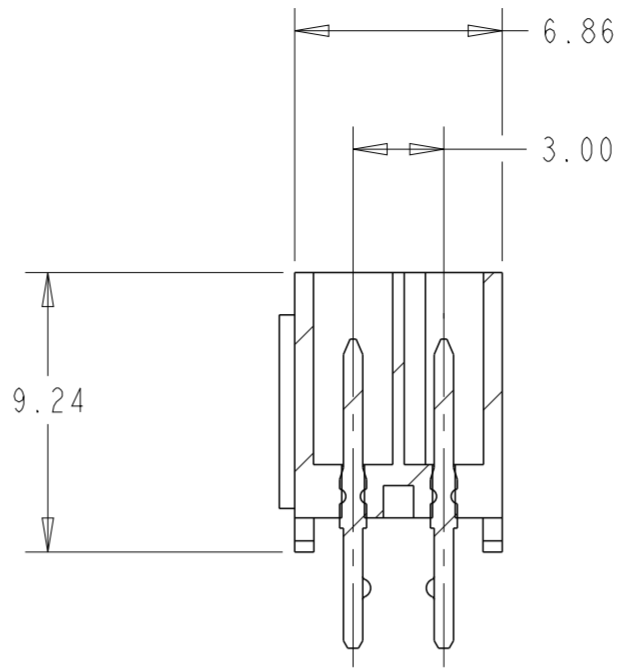
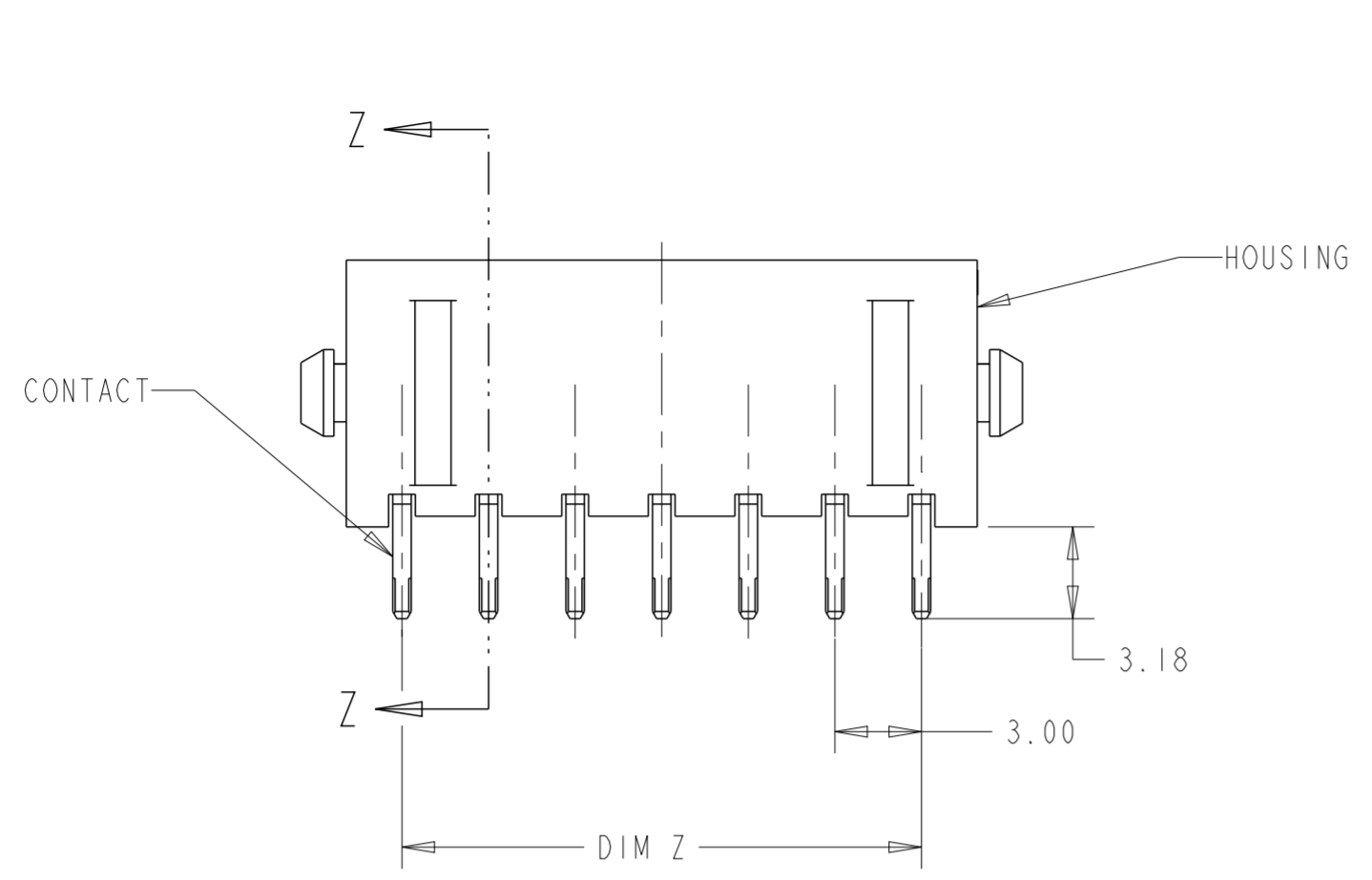

SECTION Z-Z

- 1 MATERIAL: HOUSING - NYLON, UL 94V-0, BLACK.
CONTACT - BRASS.
0.00254 MINIMUM TIN LEAD OVER
0.00127 MINIMUM NICKEL ALL OVER.
- 2 MAXIMUM INSERTION 20 LBS.
- 3 RECOMMENDED BOARD THICKNESS 1.57.
- 4 MATERIAL: HOUSING - NYLON, UL 94V-0, BLACK.
CONTACT - BRASS.
0.00254 MINIMUM TIN OVER
0.00127 MINIMUM NICKEL ALL OVER.

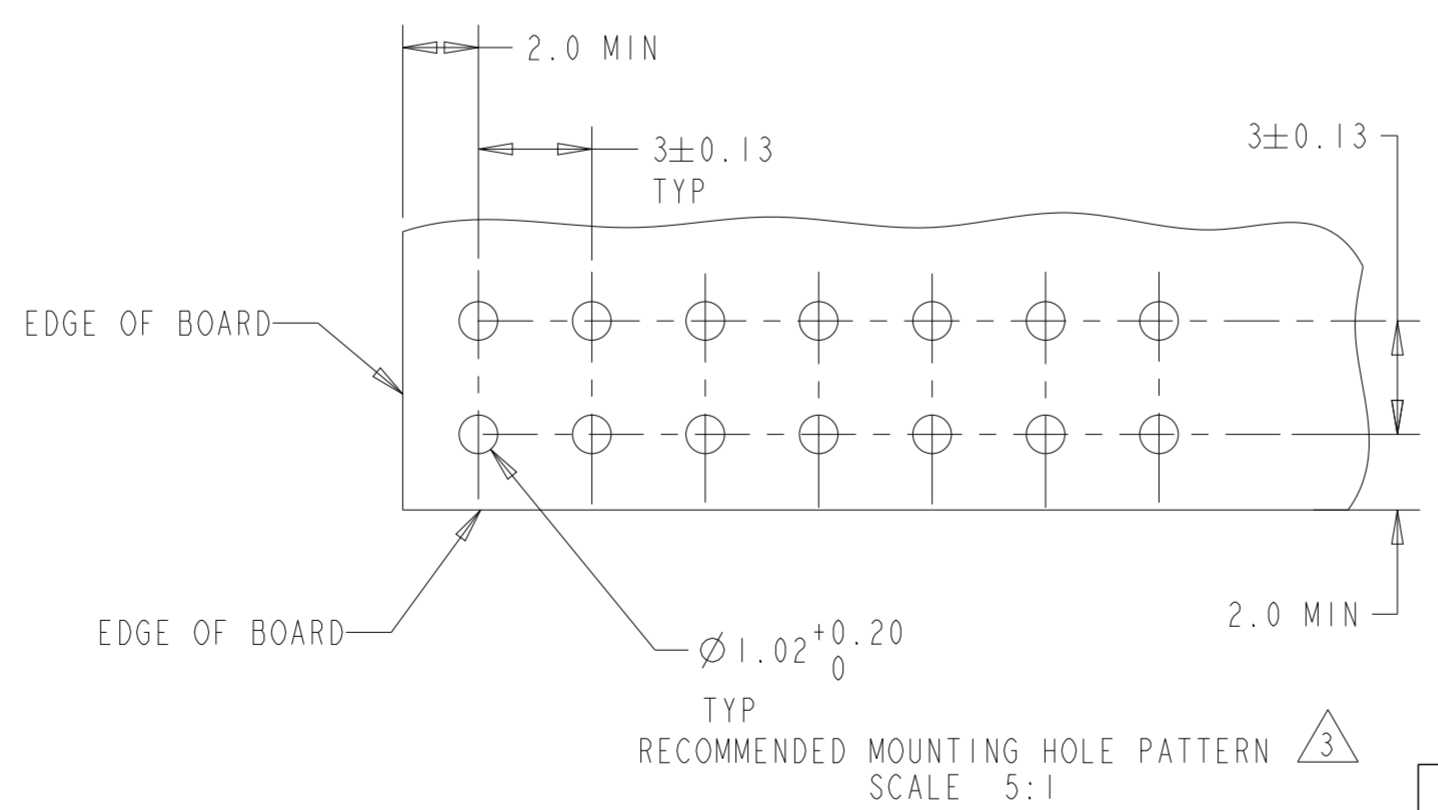
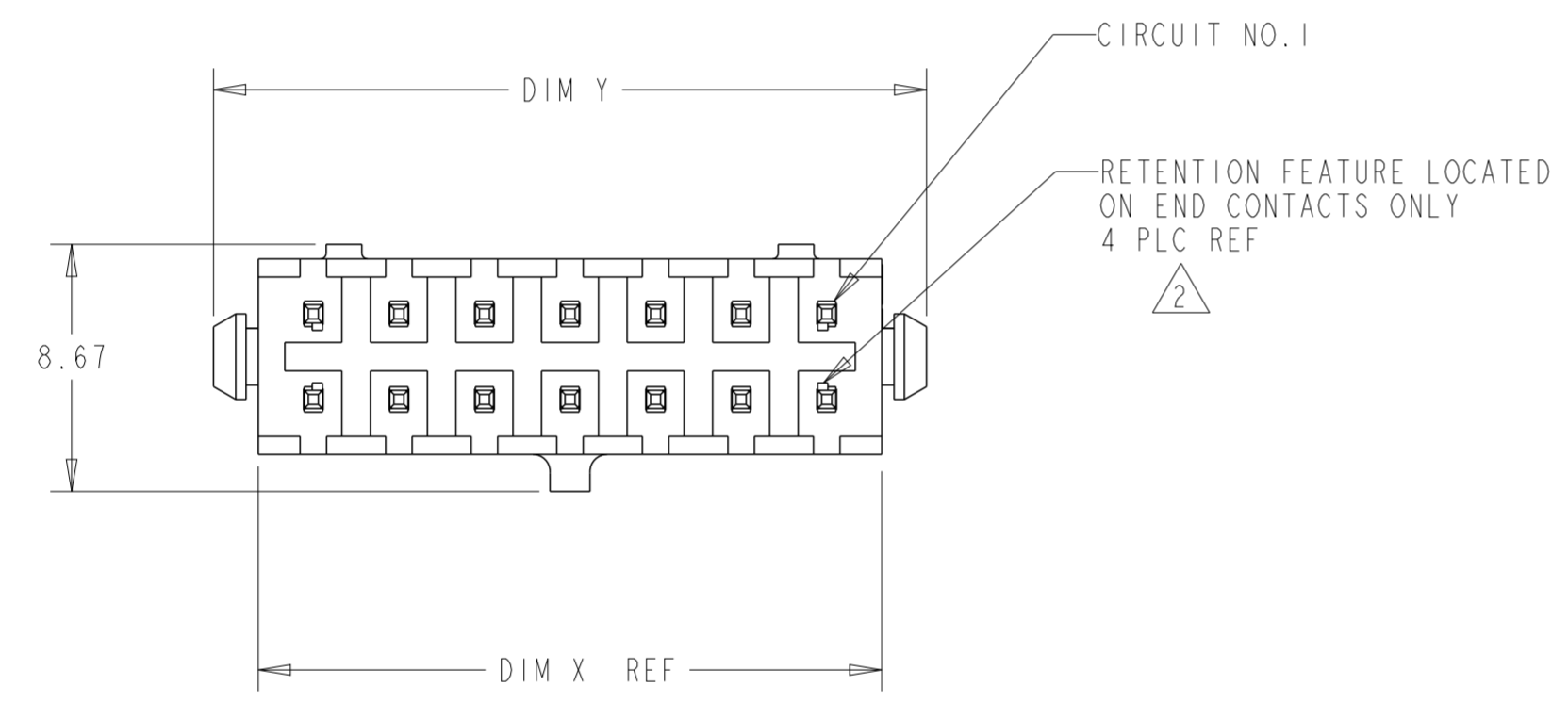

TYP RECOMMENDED MOUNTING HOLE PATTERN SCALE 5:1

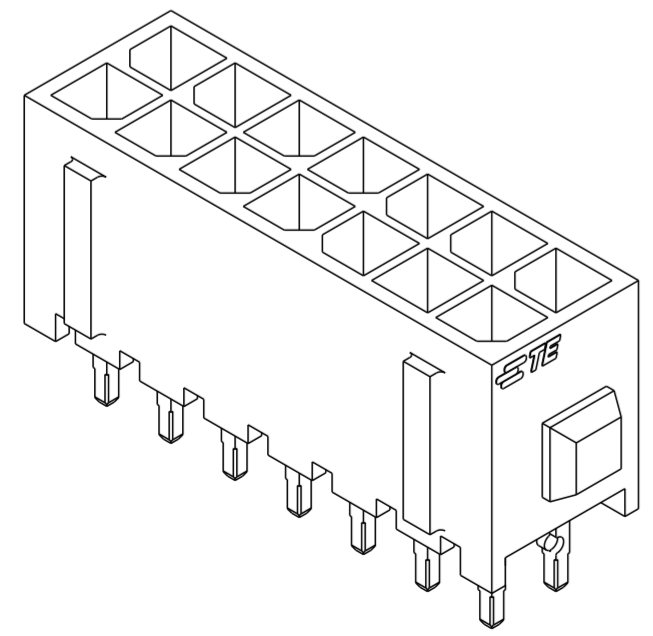

3 DIMENSIONAL MODEL

FINISH	DIM Y	DIM Z	DIM X	NO. OF POSN.	ASSEMBLY
4	40.00	33.00	36.86	24	5-794630-4
4	37.00	30.00	33.86	22	5-794630-2
4	34.00	27.00	30.86	20	5-794630-0
4	31.00	24.00	27.86	18	4-794630-8
4	28.00	21.00	24.86	16	4-794630-6
4	25.00	18.00	21.86	14	4-794630-4
4	22.00	15.00	18.86	12	4-794630-2
4	19.00	12.00	15.86	10	4-794630-0
4	16.00	9.00	12.86	8	3-794630-8
4	13.00	6.00	9.86	6	3-794630-6
4	10.00	3.00	6.86	4	3-794630-4
4	7.00	-	3.86	2	3-794630-2
1	40.00	33.00	36.86	24	2-794630-4
1	37.00	30.00	33.86	22	2-794630-2
1	34.00	27.00	30.86	20	2-794630-0
1	31.00	24.00	27.86	18	1-794630-8
1	28.00	21.00	24.86	16	1-794630-6
1	25.00	18.00	21.86	14	1-794630-4
1	22.00	15.00	18.86	12	1-794630-2
1	19.00	12.00	15.86	10	1-794630-0
1	16.00	9.00	12.86	8	794630-8
1	13.00	6.00	9.86	6	794630-6
1	10.00	3.00	6.86	4	794630-4
1	7.00	-	3.86	2	794630-2

THIS DRAWING IS A CONTROLLED DOCUMENT. DWN 20APR2005
 K. WHITAKER
 CHK 20APR2005
 C. JONES
 APVD 20APR2005
 C. JONES

TE Connectivity

NAME: VERTICAL HEADER ASSEMBLY, THRU HOLE, TIN, DUAL ROW, MICRO MATE-N-LOK(TM)

SIZE: A2 CAGE CODE: 00779 DRAWING NO: 794630 RESTRICTED TO: -

MATERIAL: SEE TABLE WEIGHT: - SCALE: 4:1 SHEET: 1 OF 1 REV: F1