



# MPY100

## MULTIPLIER-DIVIDER

### FEATURES

- LOW COST
- DIFFERENTIAL INPUT
- ACCURACY 100% TESTED AND GUARANTEED
- NO EXTERNAL TRIMMING REQUIRED
- LOW NOISE: 90 $\mu$ Vrms, 10Hz to 10kHz
- HIGHLY RELIABLE ONE-CHIP DESIGN
- DIP OR TO-100 TYPE PACKAGE
- WIDE TEMPERATURE OPERATION

### APPLICATIONS

- MULTIPLICATION
- DIVISION
- SQUARING
- SQUARE ROOT
- LINEARIZATION
- POWER COMPUTATION
- ANALOG SIGNAL PROCESSING
- ALGEBRAIC COMPUTATION
- TRUE RMS-TO-DC CONVERSION

### DESCRIPTION

The MPY100 multiplier-divider is a low cost precision device designed for general purpose application. In addition to four-quadrant multiplication, it also performs analog square root and division without the bother of external amplifiers or potentiometers. Laser-trimmed one-chip design offers the most in highly

reliable operation with guaranteed accuracies. Because of the internal reference and pretrimmed accuracies the MPY100 does not have the restrictions of other low cost multipliers. It is available in both TO-100 and DIP ceramic packages.

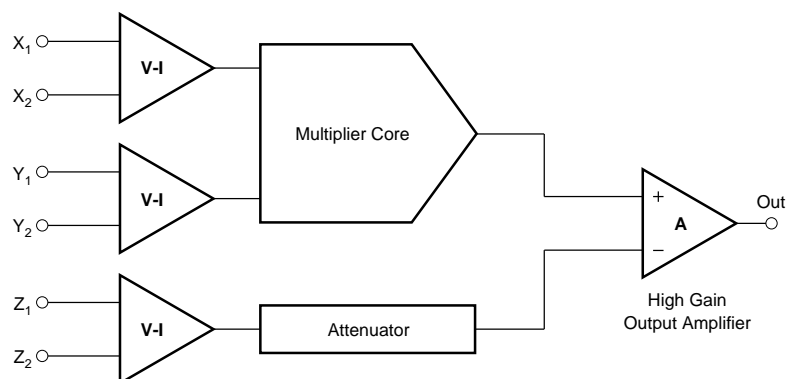

International Airport Industrial Park • Mailing Address: PO Box 11400 • Tucson, AZ 85734 • Street Address: 6730 S. Tucson Blvd. • Tucson, AZ 85706  
Tel: (520) 746-1111 • Twx: 910-952-1111 • Cable: BBRCORP • Telex: 066-6491 • FAX: (520) 889-1510 • Immediate Product Info: (800) 548-6132

# SPECIFICATIONS

At  $T_A = +25^\circ\text{C}$  and  $\pm V_S = 15\text{VDC}$ , unless otherwise specified.

PARAMETER	CONDITIONS	MPY100A			MPY100B/C			MPY100S			UNITS
		MIN	TYP	MAX	MIN	TYP	MAX	MIN	TYP	MAX	
<b>MULTIPLIER PERFORMANCE</b>											
Transfer Function		$\frac{(X_1 - X_2)(Y_1 - Y_2)}{10} + Z_2$				*/*			*		
Total Error	$-10\text{V} \leq X, Y \leq 10\text{V}$										
Initial	$T_A = +25^\circ\text{C}$			$\pm 2.0$			$\pm 1.0/0.5$			$\pm 0.5$	% FSR
vs Temperature	$-25^\circ\text{C} \leq T_A \leq +85^\circ\text{C}$		$\pm 0.017$	$\pm 0.05$		$\pm 0.008/0.008$	$\pm 0.02/0.02$				% FSR/ $^\circ\text{C}$
vs Temperature	$-55^\circ\text{C} \leq T_A \leq +125^\circ\text{C}$							$\pm 0.025$		$\pm 0.05$	% FSR/ $^\circ\text{C}$
vs Supply <sup>(1)</sup>			$\pm 0.05$			*/*		*			% FSR/%
<b>Individual Errors</b>											
<b>Output Offset</b>											
Initial	$T_A = +25^\circ\text{C}$		$\pm 50$	$\pm 100$		$\pm 10/7$	$\pm 50/25$		$\pm 7$	$\pm 50$	mV
vs Temperature	$-25^\circ\text{C} \leq T_A \leq +85^\circ\text{C}$		$\pm 0.7$	$\pm 2.0$		$\pm 0.7/0.3$	$\pm 2.0/\pm 0.7$				mV/ $^\circ\text{C}$
vs Temperature	$-55^\circ\text{C} \leq T_A \leq +125^\circ\text{C}$							$\pm 0.3$		$\pm 0.7$	mV/ $^\circ\text{C}$
vs Supply <sup>(1)</sup>			$\pm 0.25$			*/*		*			mV/%
<b>Scale Factor Error</b>											
Initial	$T_A = +25^\circ\text{C}$		$\pm 0.12$			*/*			*		% FSR
vs Temperature	$-25^\circ\text{C} \leq T_A \leq +85^\circ\text{C}$		$\pm 0.008$			*/*					% FSR/ $^\circ\text{C}$
vs Temperature	$-55^\circ\text{C} \leq T_A \leq +125^\circ\text{C}$							$\pm 0.008$			% FSR/ $^\circ\text{C}$
vs Supply <sup>(1)</sup>			$\pm 0.05$			*/*		*			% FSR %
<b>Nonlinearity</b>											
X Input	$X = 20\text{Vp-p}; Y = \pm 10\text{VDC}$		$\pm 0.08$			*/*			*		% FSR
Y Input	$Y = 20\text{Vp-p}; X = \pm 10\text{VDC}$		$\pm 0.08$			*/*			*		% FSR
<b>Feedthrough</b>											
	$f = 50\text{Hz}$										
X Input	$X = 20\text{Vp-p}; Y = 0$		100			30/30			30		mVp-p
Y Input	$Y = 20\text{Vp-p}; X = 0$		6			*/*			*		mVp-p
vs Temperature	$-25^\circ\text{C} \leq T_A \leq +85^\circ\text{C}$		0.1			*/*					mVp-p/ $^\circ\text{C}$
vs Temperature	$-55^\circ\text{C} \leq T_A \leq 125^\circ\text{C}$								0.1		mVp-p/ $^\circ\text{C}$
vs Supply <sup>(1)</sup>			0.15			*/*			*		mVp-p/%
<b>DIVIDER PERFORMANCE</b>											
Transfer Function	$X_1 > X_2$	$\frac{10(Z_2 - Z_1)}{(X_1 - X_2)} + Y_1$				*/*			*		
Total Error (with external adjustments)	$X = 10\text{V}$ $-10\text{V} \leq Z \leq +10\text{V}$ $X = 1\text{V}$ $-1\text{V} \leq Z \leq +1\text{V}$ $+0.2\text{V} \leq X \leq +10\text{V}$ $-10\text{V} \leq Z \leq +10\text{V}$		$\pm 1.5$			$\pm 0.75/0.35$			$\pm 0.35$		% FSR
			$\pm 4.0$			$\pm 2.0/1.0$			$\pm 1.0$		% FSR
			$\pm 5.0$			$\pm 2.5/1.0$			$\pm 1.0$		% FSR
<b>SQUARER PERFORMANCE</b>											
Transfer Function		$\frac{(X_1 - X_2)^2}{10} + Z_2$				*/*			*		
Total Error	$-10\text{V} \leq X \leq +10\text{V}$		$\pm 1.2$			$\pm 0.6/0.3$			$\pm 0.3$		% FSR
<b>SQUARE ROOTER PERFORMANCE</b>											
Transfer Function	$Z_1 < Z_2$	$+\sqrt{10(Z_2 - Z_1)} + X_2$				*/*			*		
Total Error	$1\text{V} \leq Z \leq 10\text{V}$		$\pm 2$			$\pm 1/0.5$			$\pm 0.5$		% FSR
<b>AC PERFORMANCE</b>											
Small-Signal Bandwidth			550			*/*			*		kHz
% Amplitude Error	Small-Signal		70			*/*			*		kHz
(0.57°) Vector Error	Small-Signal		5			*/*			*		kHz
Full Power Bandwidth	$ V_O  = 10\text{V}, R_L = 2\text{k}\Omega$		320			*/*			*		kHz
Slew Rate	$ V_O  = 10\text{V}, R_L = 2\text{k}\Omega$		20			*/*			*		V/ $\mu\text{s}$
Settling Time	$\varepsilon = \pm 1\%, \Delta V_O = 20\text{V}$		2			*/*			*		$\mu\text{s}$
Overload Recovery	50% Output Overload		0.2			*/*			*		$\mu\text{s}$
<b>INPUT CHARACTERISTICS</b>											
Input Voltage Range		$\pm 10$				*/*			*		V
Rated Operation											V
Absolute Maximum				$\pm V_{CC}$			*/*			*	V
Input Resistance	X, Y, Z <sup>(2)</sup>		10			*/*			*		M $\Omega$
Input Bias Current	X, Y, Z		1.4			*/*			*		$\mu\text{A}$
<b>OUTPUT CHARACTERISTICS</b>											
Rated Output											
Voltage	$I_O = \pm 5\text{mA}$	$\pm 10$				*/*			*		V
Current	$V_O = \pm 10\text{V}$	$\pm 5$				*/*			*		mA
Output Resistance	$f = \text{DC}$		1.5			*/*			*		$\Omega$

# SPECIFICATIONS (CONT)

At  $T_A = +25^\circ\text{C}$  and  $\pm V_S = 15\text{VDC}$ , unless otherwise specified.

PARAMETER	CONDITIONS	MPY100A			MPY100B/C			MPY100S			UNITS
		MIN	TYP	MAX	MIN	TYP	MAX	MIN	TYP	MAX	
<b>OUTPUT NOISE VOLTAGE</b> $f_O = 1\text{Hz}$ $f_O = 1\text{kHz}$ $1/f$ Corner Frequency $f_B = 5\text{Hz to } 10\text{kHz}$ $f_B = 5\text{Hz to } 5\text{MHz}$	$X = Y = 0$		6.2 0.6 110 60 1.3			*/ */ */ */ */			** * * *		$\mu\text{V}/\sqrt{\text{Hz}}$ $\mu\text{V}/\sqrt{\text{Hz}}$ Hz $\mu\text{Vrms}$ mVrms
<b>POWER SUPPLY REQUIREMENTS</b> Rated Voltage Operating Range Quiescent Current	Derated Performance	$\pm 8.5$	$\pm 15$ $\pm 5.5$	$\pm 20$	*/ */	*/ */	*/ */	**	**	**	VDC VDC mA
<b>TEMPERATURE RANGE</b> (Ambient) Specification Operating Range Storage	Derated Performance	-25 -55 -65		+85 +125 +150	*/ */ */		*/ */ */	-55 *		+125 * *	$^\circ\text{C}$ $^\circ\text{C}$ $^\circ\text{C}$

\* Same as MPY100A specification.

\*/ B/C grades same as MPY100A specification.

NOTES: (1) Includes effects of recommended null pots. (2)  $Z_2$  input resistance is  $10\text{M}\Omega$ , typical, with  $V_{OS}$  pin open. If  $V_{OS}$  pin is grounded or used for optional offset adjustment, the  $Z_2$  input resistance may be as low as  $25\text{k}\Omega$ .

## PIN CONFIGURATIONS

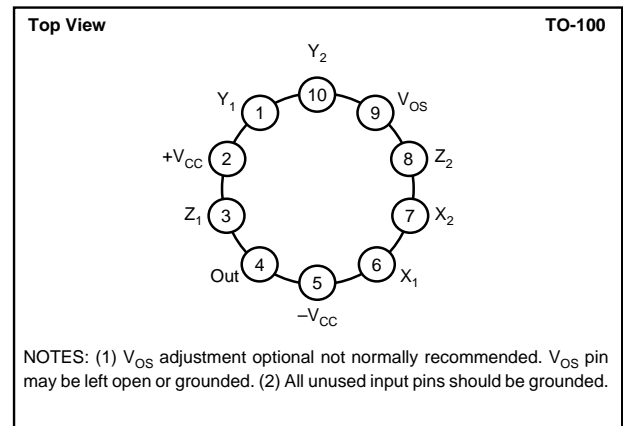
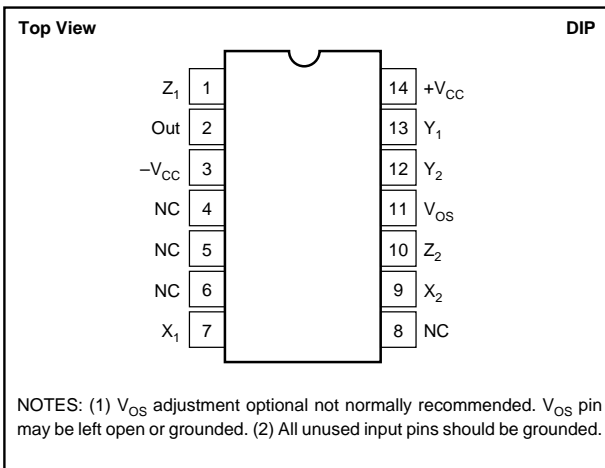

## ABSOLUTE MAXIMUM RATINGS

Supply .....	$\pm 20\text{VDC}$
Internal Power Dissipation <sup>(1)</sup> .....	500mW
Differential Input Voltage <sup>(2)</sup> .....	$\pm 40\text{VDC}$
Input Voltage Range <sup>(2)</sup> .....	$\pm 20\text{VDC}$
Storage Temperature Range .....	$-65^\circ\text{C}$ to $+150^\circ\text{C}$
Operating Temperature Range .....	$-55^\circ\text{C}$ to $+125^\circ\text{C}$
Lead Temperature (soldering, 10s) .....	$+300^\circ\text{C}$
Output Short-circuit Duration <sup>(3)</sup> .....	Continuous
Junction Temperature .....	$+150^\circ\text{C}$

NOTES: (1) Package must be derated on  $\theta_{JC} = 15^\circ\text{C}/\text{W}$  and  $\theta_{JA} = 165^\circ\text{C}/\text{W}$  for the metal package and  $\theta_{JC} = 35^\circ\text{C}/\text{W}$  and  $\theta_{JA} = 220^\circ\text{C}/\text{W}$  for the ceramic package. (2) For supply voltages less than  $\pm 20\text{VDC}$ , the absolute maximum input voltage is equal to the supply voltage. (3) Short-circuit may be to ground only. Rating applies to  $+85^\circ\text{C}$  ambient for the metal package and  $+65^\circ\text{C}$  for the ceramic package.

## ORDERING INFORMATION

MODEL	PACKAGE	TEMPERATURE RANGE
MPY100AG	14-Pin Ceramic DIP	$-25^\circ\text{C}$ to $+85^\circ\text{C}$
MPY100AM	Metal TO-100	$-25^\circ\text{C}$ to $+85^\circ\text{C}$
MPY100BG	14-Pin Ceramic DIP	$-25^\circ\text{C}$ to $+85^\circ\text{C}$
MPY100BM	Metal TO-100	$-25^\circ\text{C}$ to $+85^\circ\text{C}$
MPY100CG	14-Pin Ceramic DIP	$-25^\circ\text{C}$ to $+85^\circ\text{C}$
MPY100CM	Metal TO-100	$-25^\circ\text{C}$ to $+85^\circ\text{C}$
MPY100SG	14-Pin Ceramic DIP	$-55^\circ\text{C}$ to $+125^\circ\text{C}$
MPY100SM	Metal TO-100	$-55^\circ\text{C}$ to $+125^\circ\text{C}$

## PACKAGE INFORMATION

MODEL	PACKAGE	PACKAGE DRAWING NUMBER <sup>(1)</sup>
MPY100AG	14-Pin Ceramic DIP	169
MPY100AM	Metal TO-100	007
MPY100BG	14-Pin Ceramic DIP	169
MPY100BM	Metal TO-100	007
MPY100CG	14-Pin Ceramic DIP	169
MPY100CM	Metal TO-100	007
MPY100SG	14-Pin Ceramic DIP	169
MPY100SM	Metal TO-100	007

NOTE: (1) For detailed drawing and dimension table, please see end of data sheet, or Appendix D of Burr-Brown IC Data Book.

### SIMPLIFIED SCHEMATIC

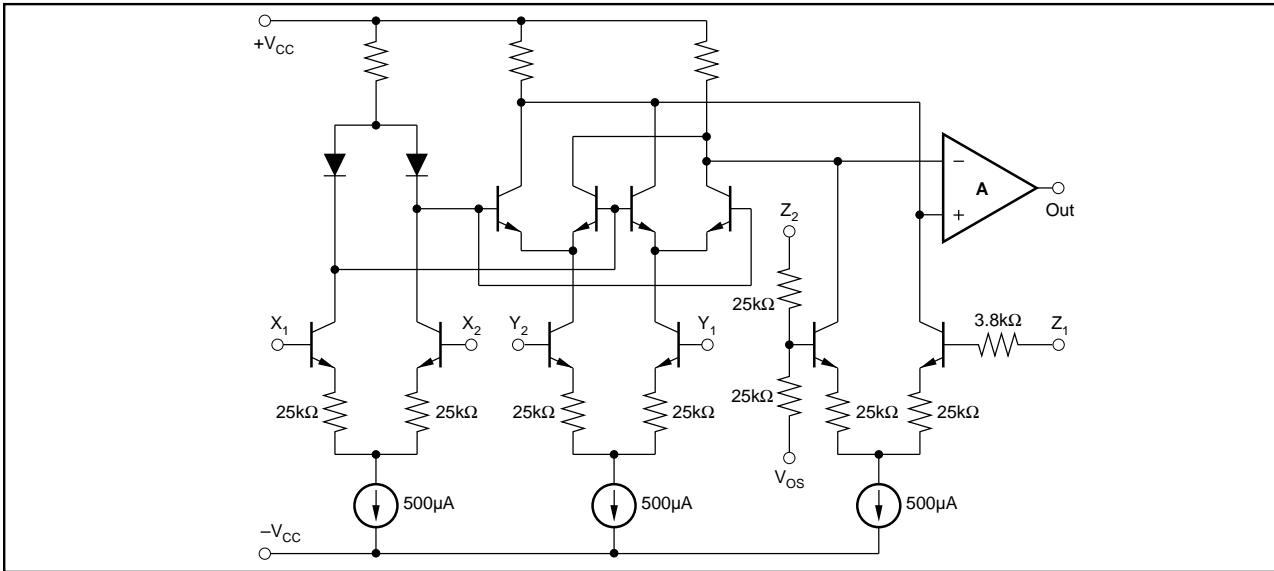

### CONNECTION DIAGRAM

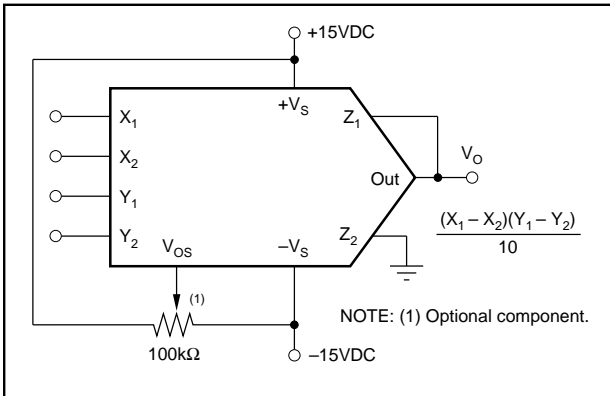

### DICE INFORMATION

**MPY100 DIE TOPOGRAPHY**

PAD	FUNCTION
1	Y <sub>2</sub>
2	V <sub>OS</sub>
3	Z <sub>2</sub>
4	X <sub>2</sub>
5	X <sub>1</sub>
6	V <sub>O</sub>
7	Z <sub>1</sub>
8	+V
9	-V
10	Y <sub>1</sub>

Substrate Bias: -V<sub>CC</sub>

#### MECHANICAL INFORMATION

	MILS (0.001")	MILLIMETERS
Die Size	107 x 93 ±5	2.72 x 2.36 ±0.13
Die Thickness	20 ±3	0.51 ±0.08
Min. Pad Size	4 x 4	0.10 x 0.10
Backing		Gold

# TYPICAL PERFORMANCE CURVES

At  $T_A = +25^\circ\text{C}$  and  $\pm V_S = 15\text{VDC}$ , unless otherwise specified.

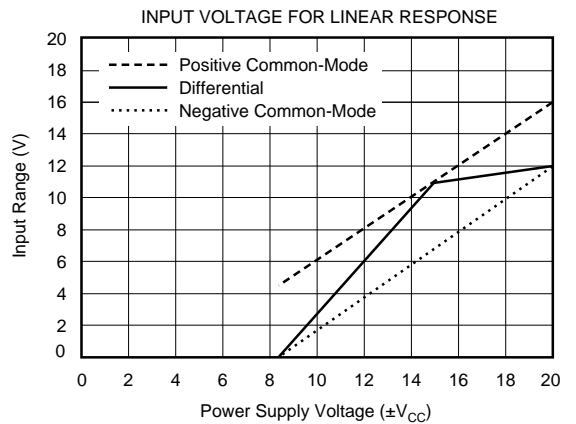
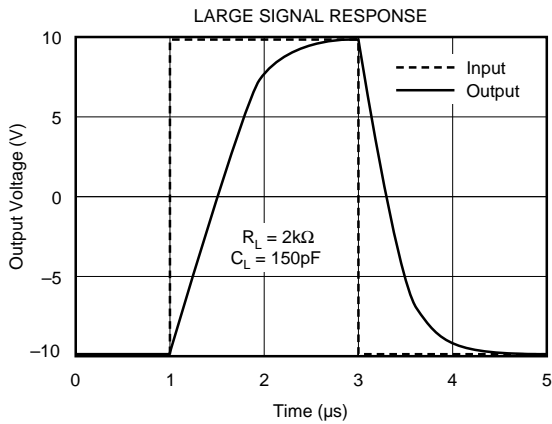
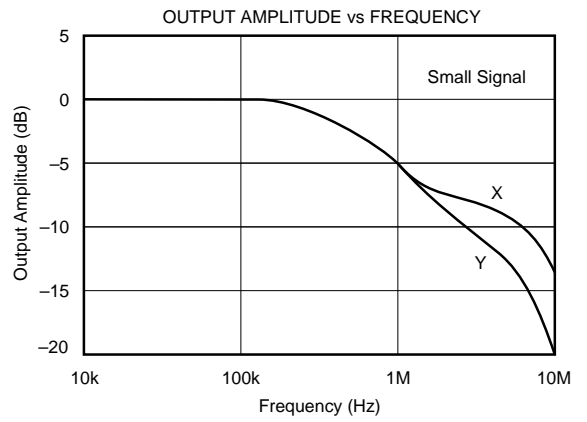
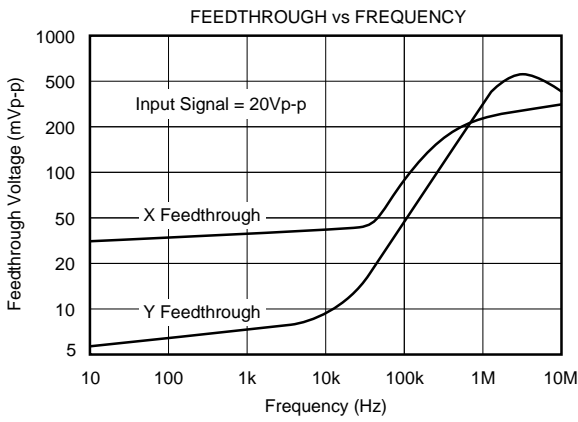
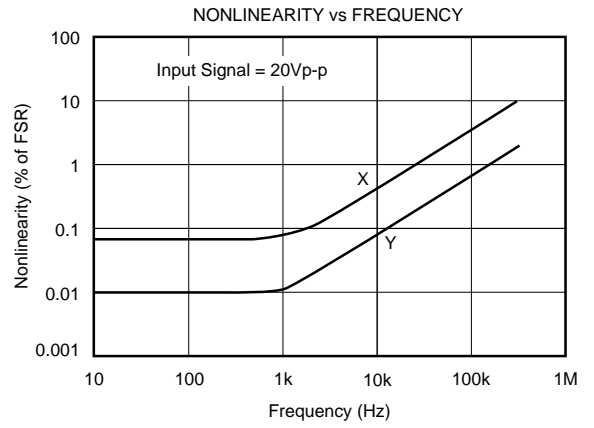
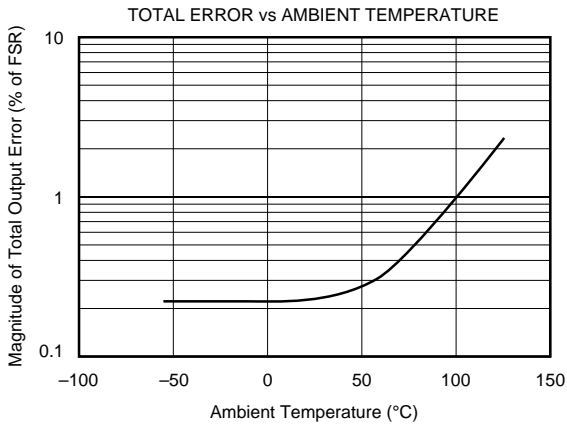

# TYPICAL PERFORMANCE CURVES (CONT)

At  $T_A = +25^\circ\text{C}$  and  $\pm V_S = 15\text{VDC}$ , unless otherwise specified.

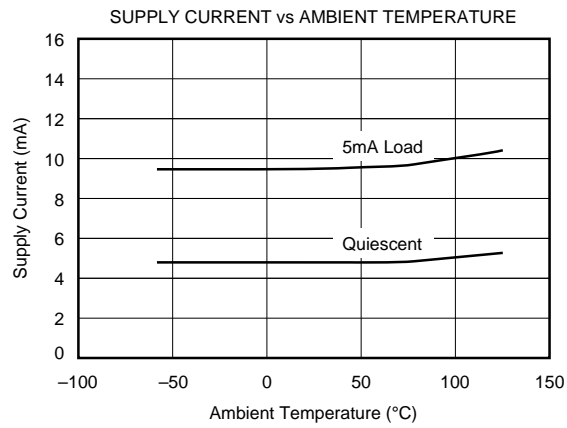
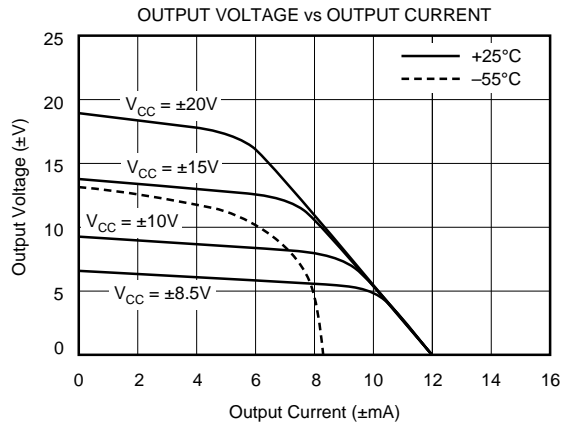
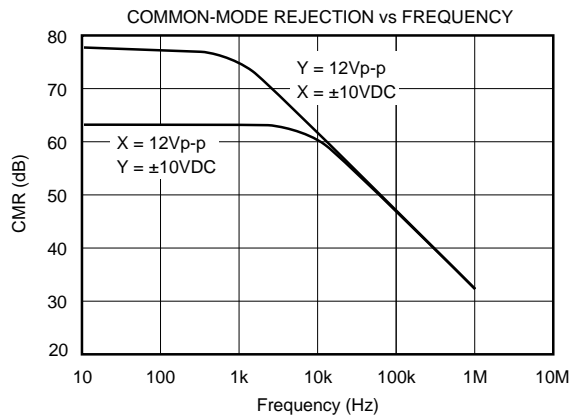

# THEORY OF OPERATION

The MPY100 is a variable transconductance multiplier consisting of three differential voltage-to-current converters, a multiplier core and an output differential amplifier as illustrated in Figure 1.

The basic principle of the transconductance multiplier can be demonstrated by the differential stage in Figure 2.

For small values of the input voltage,  $V_1$ , that are much smaller than  $V_T$ , the transistor's thermal voltage, the differential output voltage,  $V_O$ , is:

$$V_O = g_m R_L V_1$$

The transconductance  $g_m$  of the stage is given by:

$$g_m = I_E/V_T$$

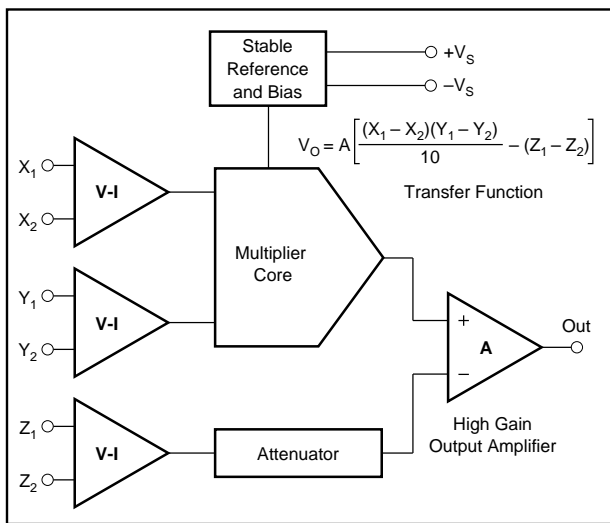

FIGURE 1. MPY100 Functional Block Diagram.

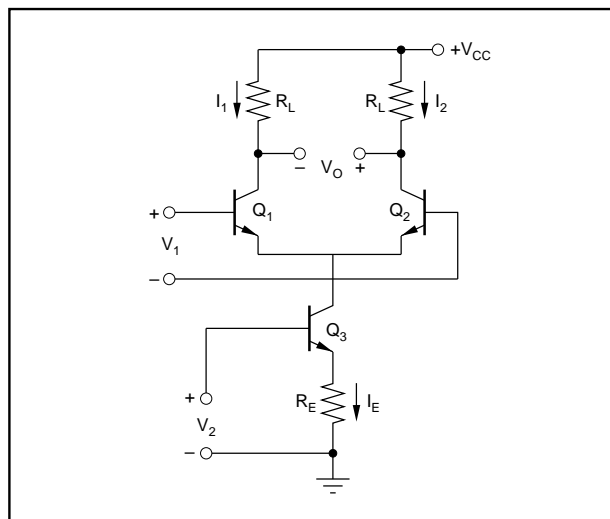

FIGURE 2. Basic Differential Stage as a Transconductance Multiplier.

and is modulated by the voltage,  $V_2$ , to give

$$g_m \approx V_2/V_T R_E$$

Substituting this into the original equation yields the overall transfer function

$$V_O = g_m R_L V_1 = V_1 V_2 (R_L/V_T R_E)$$

which shows the output voltage to be the product of the two input voltages,  $V_1$  and  $V_2$ .

Variations in  $I_E$  due to  $V_2$  cause a large common-mode voltage swing in the circuit. The errors associated with this common-mode voltage can be eliminated by using two differential stages in parallel and cross-coupling their outputs as shown in Figure 3.

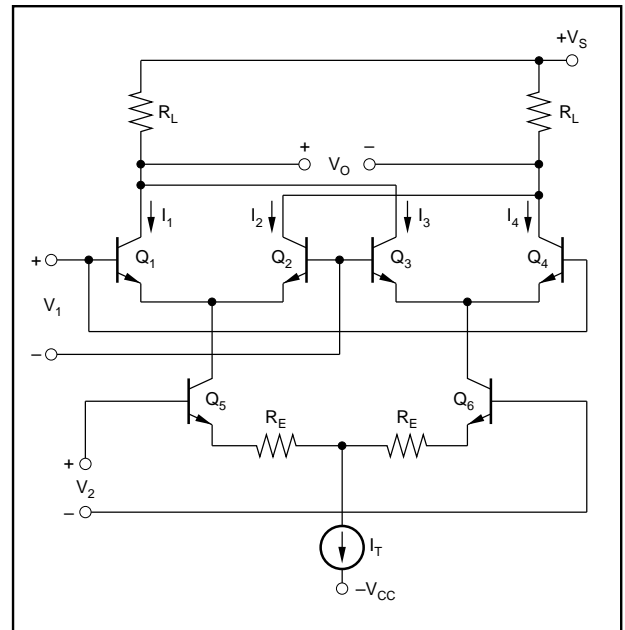

FIGURE 3. Cross-Coupled Differential Stages as a Variable-Transconductance Multiplier.

An analysis of the circuit in Figure 3 shows it to have the same overall transfer function as before:

$$V_O = V_1 V_2 (R_L/V_T R_E).$$

For input voltages larger than  $V_T$ , the voltage-to-current transfer characteristics of the differential pair  $Q_1, Q_2$  or  $Q_3$  and  $Q_4$  are no longer linear. Instead, their collector currents are related to the applied voltage  $V_1$

$$\frac{I_1}{I_2} = \frac{I_3}{I_4} = e^{\frac{V_1}{V_T}}$$

The resultant nonlinearity can be overcome by developing  $V_1$  logarithmically to exactly cancel the exponential relationship just derived. This is done by diodes  $D_1$  and  $D_2$  in Figure 4.

The emitter degeneration resistors,  $R_X$  and  $R_Y$ , in Figure 4, provide a linear conversion of the input voltages to differential current,  $I_X$  and  $I_Y$ , where:

$$I_X = V_X/R_X \text{ and } I_Y = V_Y/R_Y$$

Analysis of Figure 4 shows the voltage  $V_A$  to be:

$$V_A = (2R_L/I_1)(I_X I_Y)$$

Since  $I_X$  and  $I_Y$  are linearly related to the input voltages  $V_X$  and  $V_Y$ ,  $V_A$  may also be written:

$$V_A = KV_X V_Y$$

where  $K$  is a scale factor. In the MPY100,  $K$  is chosen to be 0.1.

The addition of the  $Z$  input alters the voltage  $V_A$  to:

$$V_A = KV_X V_Y - V_Z$$

Therefore, the output of the MPY100 is:

$$V_O = A[KV_X V_Y - V_Z]$$

where  $A$  is the open-loop gain of the output amplifier. Writing this last equation in terms of the separate inputs to the MPY100 gives

$$V_O = A \left[ \frac{(X_1 - X_2)(Y_1 - Y_2)}{10} - (Z_1 - Z_2) \right]$$

the transfer function of the MPY100.

## WIRING PRECAUTIONS

In order to prevent frequency instability due to lead inductance of the power supply lines, each power supply should be bypassed. This should be done by connecting a 10 $\mu$ F tantalum capacitor in parallel with a 1000pF ceramic capacitor from the + $V_{CC}$  and - $V_{CC}$  pins of the MPY100 to the power supply common. The connection of these capacitors should be as close to the MPY100 as practical.

## CAPACITIVE LOADS

Stable operation is maintained with capacitive loads to 1000pF in all modes, except the square root mode for which 50pF is a safe upper limit. Higher capacitive loads can be driven if a 100 $\Omega$  resistor is connected in series with the MPY100's output.

## DEFINITIONS

### TOTAL ERROR (Accuracy)

Total error is the actual departure of the multiplier output voltage from the ideal product of its input voltages. It includes the sum of the effects of input and output DC offsets, gain error and nonlinearity.

### OUTPUT OFFSET

Output offset is the output voltage when both inputs  $V_X$  and  $V_Y$  are 0V.

### SCALE FACTOR ERROR

Scale factor error is the difference between the actual scale factor and the ideal scale factor.

### NONLINEARITY

Nonlinearity is the maximum deviation from a best straightline (curve fitting on input-output graph) expressed as a percent of peak-to-peak full scale output.

### FEEDTHROUGH

Feedthrough is the signal at the output for any value of  $V_X$  or  $V_Y$  within the rated range, when the other input is zero.

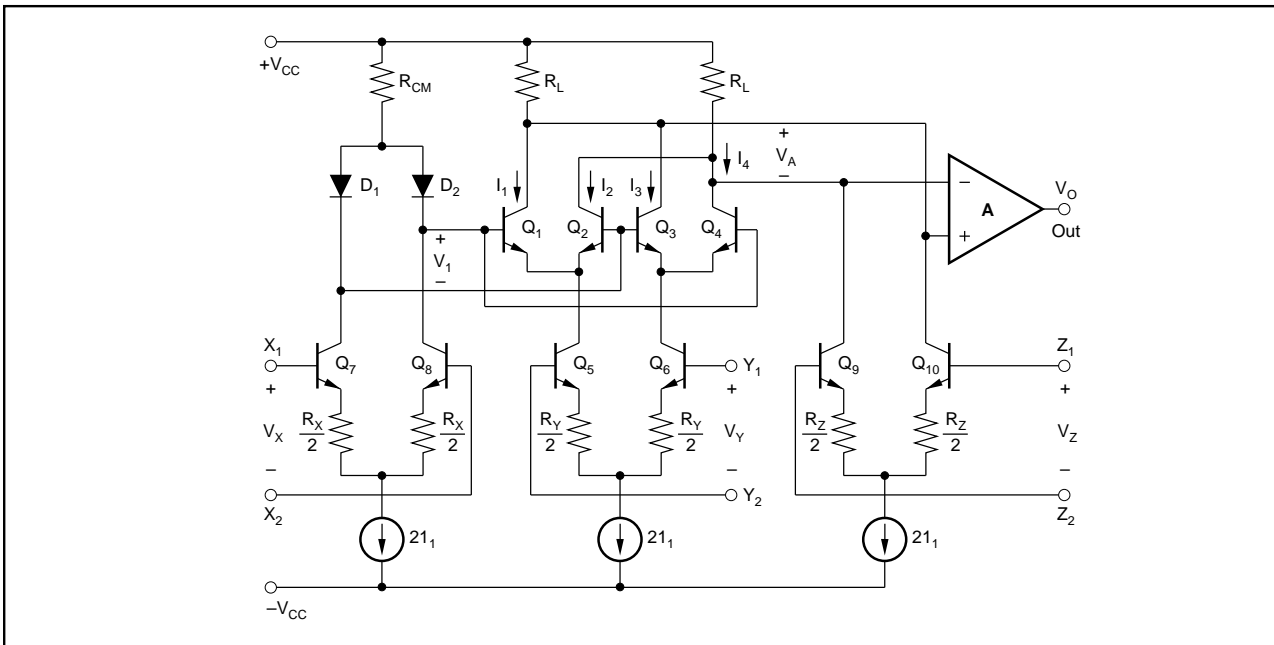

FIGURE 4. MPY100 Simplified Circuit Diagram.



## SMALL SIGNAL BANDWIDTH

Small signal bandwidth is the frequency at which the output is down 3dB from its low-frequency value for nominal output amplitude of 10% of full scale.

## 1% AMPLITUDE ERROR

The 1% amplitude error is the frequency the output amplitude is in error by 1%, measured with an output amplitude of 10% of full scale.

## 1% VECTOR ERROR

The 1% vector error is the frequency at which a phase error of 0.01 radians (0.57°) occurs. This is the most sensitive measure of dynamic error of a multiplier.

# TYPICAL APPLICATIONS

## MULTIPLICATION

Figure 5 shows the basic connection for four-quadrant multiplication.

The MPY100 meets all of its specifications without trimming. Accuracy can, however be improved over a limited range by nulling the output offset voltage using the 100Ω optional balance potentiometer shown in Figure 5.

AC feedthrough may be reduced to a minimum by applying an external voltage to the X or Y input as shown in Figure 6.

Z<sub>2</sub>, the optional summing input, may be used to sum a voltage into the output of the MPY100. If not used, this terminal, as well as the X and Y input terminals, should be grounded. All inputs should be referenced to power supply common.

Figure 7 shows how to achieve a scale factor larger than the nominal 1/10. In this case, the scale factor is unity which makes the transfer function

$$V_O = KV_X V_Y = K(X_1 - X_2)(Y_1 - Y_2)K = \left[ \frac{1 + (R_1/R_2)}{10} \right]$$

$0.1 \leq K \leq 1$

This circuit has the disadvantage of increasing the output offset voltage by a factor of 10, which may require the use of the optional balance control as in Figure 1 for some applications. In addition, this connection reduces the small signal bandwidth to about 50kHz.

## DIVISION

Figure 8 shows the basic connection for two-quadrant division. This configuration is a multiplier-inverted analog divider, i.e., a multiplier connected in the feedback loop of an operational amplifier. In the case of the MPY100, this operational amplifier is the output amplifier shown in Figure 1.

The divider error with a multiplier-inverted analog divider is approximately:

$$\epsilon_{\text{DIVIDER}} = 10 \epsilon_{\text{MULTIPLIER}} / (X_1 - X_2)$$

It is obvious from this error equation that divider error becomes excessively large for small values of X<sub>1</sub> - X<sub>2</sub>. A 10-to-1 denominator range is usually the practical limit. If more accurate division is required over a wide range of denominator voltages, an externally generated voltage may be

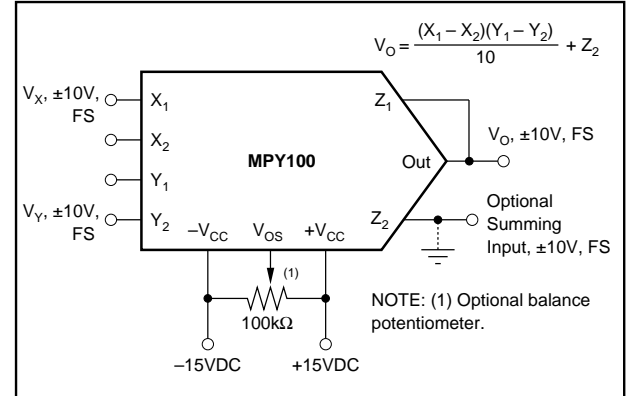

FIGURE 5. Multiplier Connection.

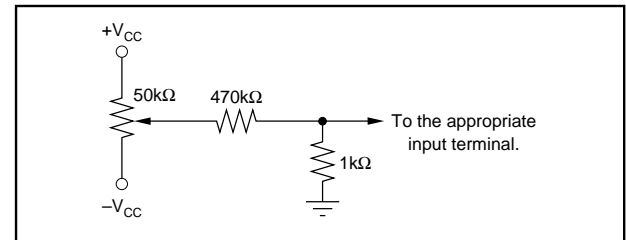

FIGURE 6. Optional Trimming Configuration.

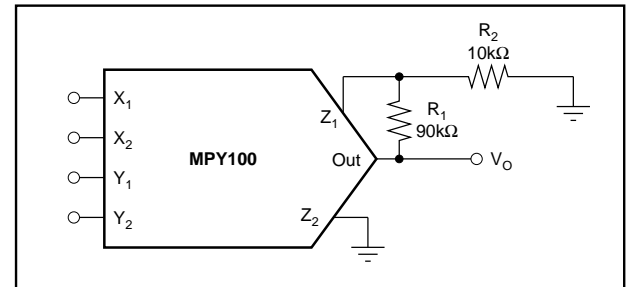

FIGURE 7. Connection for Unity Scale Factor.

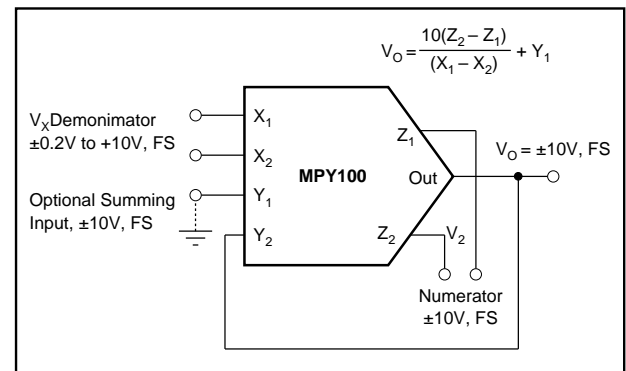

FIGURE 8. Divider Connection.

applied to the unused X-input (see Optional Trim Configuration). To trim, apply a ramp of +100mV to +1V at 100Hz to both  $X_1$  and  $Z_1$  if  $X_2$  is used for offset adjustment, otherwise reverse the signal polarity and adjust the trim voltage to minimize the variation in the output. An alternative to this procedure would be to use the Burr-Brown DIV100, a precision log-antilog divider.

### SQUARING

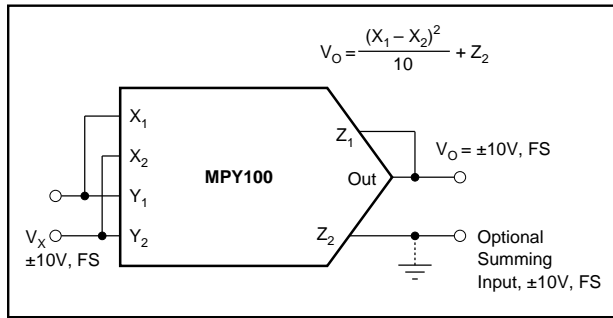

FIGURE 9. Squarer Connection.

### SQUARE ROOT

Figure 10 shows the connection for taking the square root of the voltage  $V_Z$ . The diode prevents a latching condition which could occur if the input momentarily changed polarity. This latching condition is not a design flaw in the MPY100, but occurs when a multiplier is connected in the feedback loop of an operational amplifier to perform square root functions.

The load resistance,  $R_L$ , must be in the range of  $10k\Omega \leq R_L \leq 1M\Omega$ . This resistance must be in the circuit as it provides the current necessary to operate the diode.

### PERCENTAGE COMPUTATION

The circuit of Figure 11 has a sensitivity of 1V/% and is capable of measuring 10% deviations. Wider deviation can be measured by decreasing the ratio of  $R_2/R_1$ .

### BRIDGE LINEARIZATION

The use of the MPY100 to linearize the output from a bridge circuit makes the output  $V_O$  independent of the bridge supply voltage. See Figure 12.

### TRUE RMS-TO-DC CONVERSION

The rms-to-DC conversion circuit of Figure 13 gives greater accuracy and bandwidth but with less dynamic range than most rms-to-DC converters.

### SINE FUNCTION GENERATOR

The circuit in Figure 14 uses implicit feedback to implement the following sine function approximation:

$$V_O = (1.5715V_1 - 0.004317V_1^3)/(1 + 0.001398V_1^2) \\ = 10 \sin(9V_1)$$

### MORE CIRCUITS

The theory and procedures for developing virtually any function generator or linearization circuit can be found in the Burr-Brown/McGraw Hill book "FUNCTION CIRCUITS - Design and Applications."

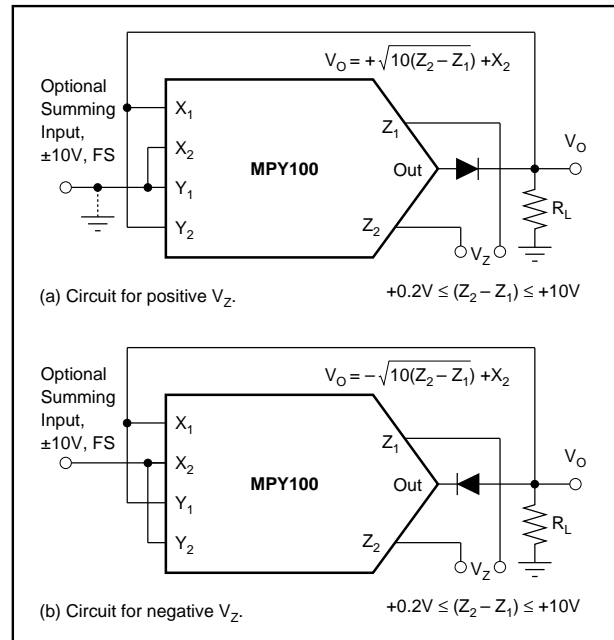

FIGURE 10. Square Root Connection.

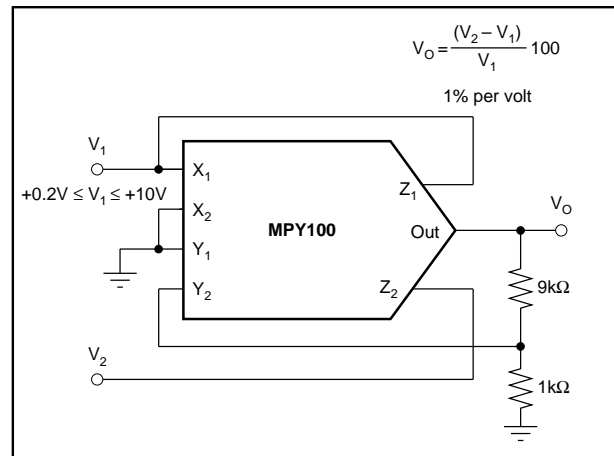

FIGURE 11. Percentage Computation.

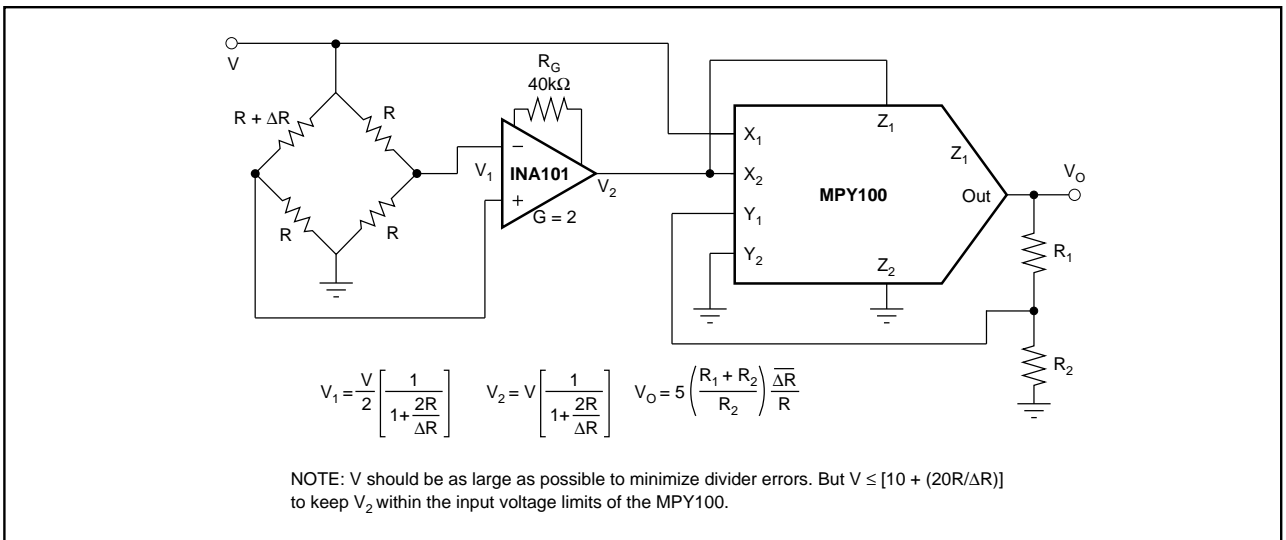

FIGURE 12. Bridge Linearization.

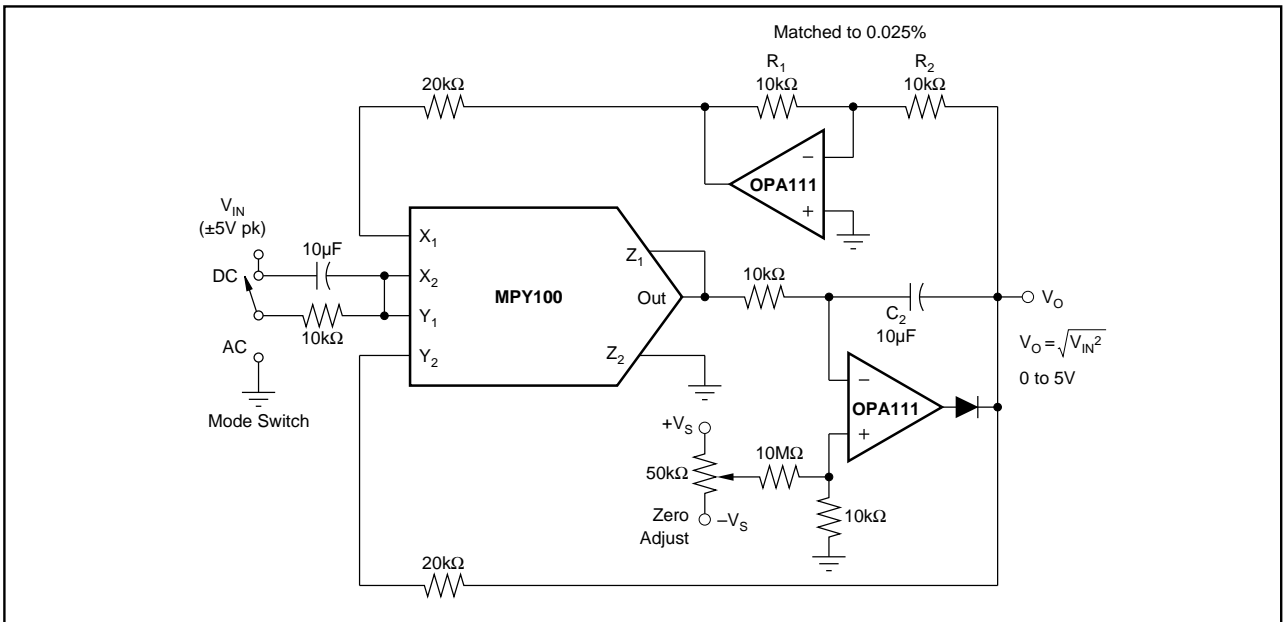

FIGURE 13. True RMS-to-DC Conversion.

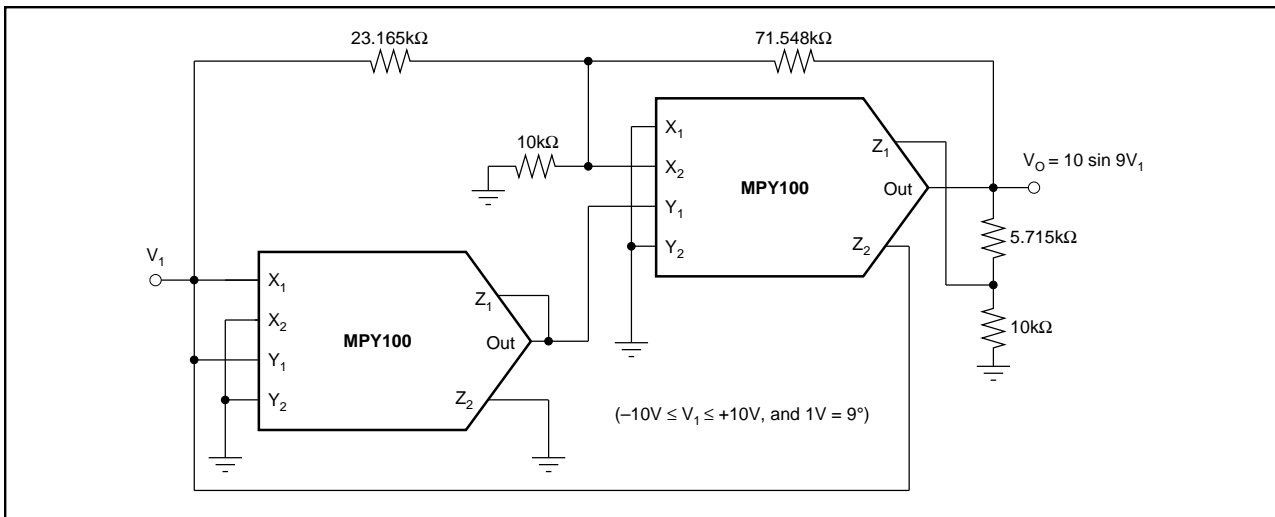

FIGURE 14. Sine Function Generator

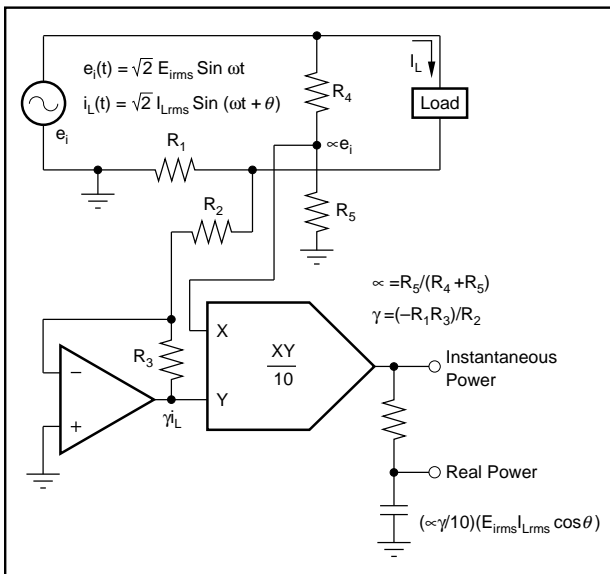

FIGURE 15. Single-Phase Instantaneous and Real Power Measurement.

The information provided herein is believed to be reliable; however, BURR-BROWN assumes no responsibility for inaccuracies or omissions. BURR-BROWN assumes no responsibility for the use of this information, and all use of such information shall be entirely at the user's own risk. Prices and specifications are subject to change without notice. No patent rights or licenses to any of the circuits described herein are implied or granted to any third party. BURR-BROWN does not authorize or warrant any BURR-BROWN product for use in life support devices and/or systems.

## **IMPORTANT NOTICE**

Texas Instruments and its subsidiaries (TI) reserve the right to make changes to their products or to discontinue any product or service without notice, and advise customers to obtain the latest version of relevant information to verify, before placing orders, that information being relied on is current and complete. All products are sold subject to the terms and conditions of sale supplied at the time of order acknowledgment, including those pertaining to warranty, patent infringement, and limitation of liability.

TI warrants performance of its semiconductor products to the specifications applicable at the time of sale in accordance with TI's standard warranty. Testing and other quality control techniques are utilized to the extent TI deems necessary to support this warranty. Specific testing of all parameters of each device is not necessarily performed, except those mandated by government requirements.

Customers are responsible for their applications using TI components.

In order to minimize risks associated with the customer's applications, adequate design and operating safeguards must be provided by the customer to minimize inherent or procedural hazards.

TI assumes no liability for applications assistance or customer product design. TI does not warrant or represent that any license, either express or implied, is granted under any patent right, copyright, mask work right, or other intellectual property right of TI covering or relating to any combination, machine, or process in which such semiconductor products or services might be or are used. TI's publication of information regarding any third party's products or services does not constitute TI's approval, warranty or endorsement thereof.