

ALL RIGHTS RESERVED. NO PORTION OF THIS PUBLICATION, WHETHER IN WHOLE OR IN PART CAN BE REPRODUCED WITHOUT THE EXPRESS WRITTEN CONSENT OF SPC TECHNOLOGY.

REVISIONS		DOC. NO.	SPC-F005	Effective:	12/21/08	DCP No:	080	
DOP #	REV	DESCRIPTION	DRAWN	DATE	CHECKD	DATE	APPRVD	DATE
	A	Released	J.C.	9/18/91				
1333	B	UPDATED TO TABULAR SPEC	HYO	2/22/02	DJC	2/22/02	DJC	2/22/02

SPC Type No.	Hole Size Ø	Prongs Number	A ±0.008	B ±0.008	C ±0.008
HP-05	0.312	6	0.438	0.062	0.250
HP-10	0.625	8	0.813	0.078	0.297
HP-14	0.875	12	1.062	0.062	0.297
HP-18	1.125	12	1.313	0.094	0.344
HP-20	1.250	12	1.438	0.094	0.344

Material: Steel, Nickel Plated

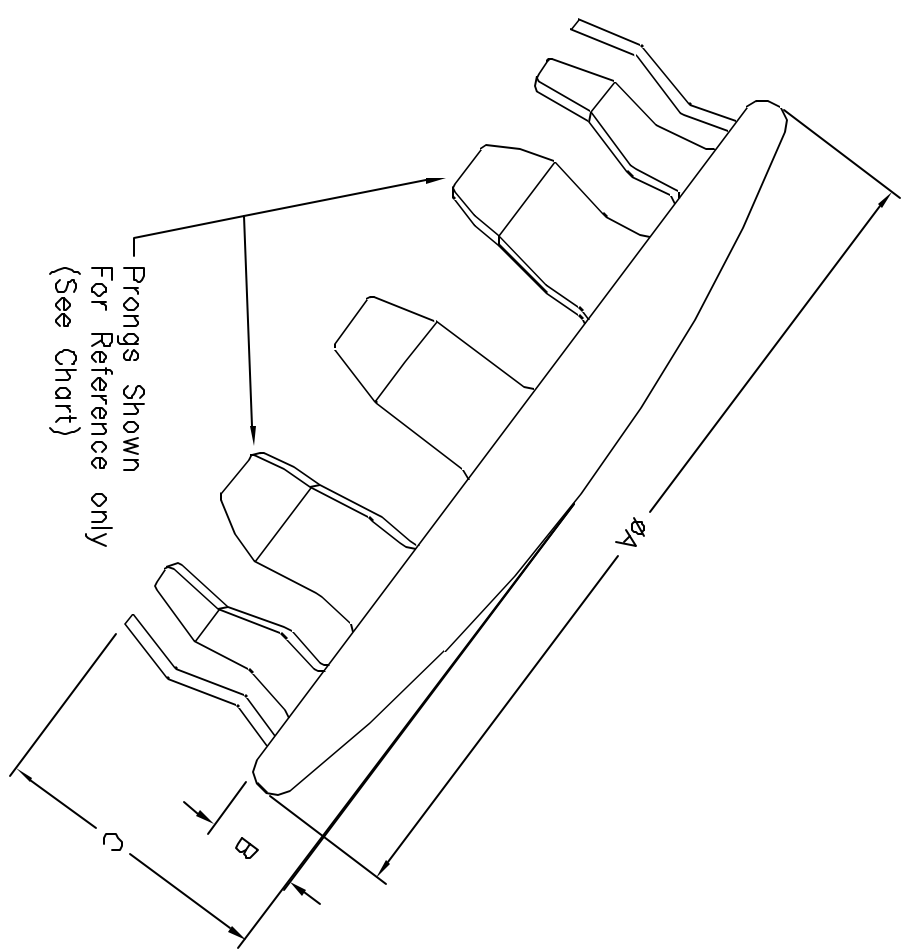

DISCLAIMER
 ALL STATEMENTS AND TECHNICAL INFORMATION CONTAINED HEREIN ARE BASED UPON INFORMATION AND/OR TESTS WE BELIEVE TO BE ACCURATE AND RELIABLE. SINCE CONDITIONS OF USE ARE BEYOND OUR CONTROL, THE USER SHALL OBTAIN THE SUPPLIERS OF THE PRODUCT FOR THE INTENDED USE AND ASSUME ALL RISK AND LIABILITY WHATSOEVER IN CONNECTION THEREWITH.

UNLESS OTHERWISE SPECIFIED, DIMENSIONS ARE FOR REFERENCE PURPOSES ONLY.

DRAWN BY:	J.C.	DATE:	9/18/91
CHECKED BY:		DATE:	
APPROVED BY:		DATE:	

SPC TECHNOLOGY

DRAWING TITLE: **SNAP BUTTON HOLE PLUG**

SIZE	DWG. NO.	ELECTRONIC FILE	REV
A	TA-495	TA-495.DWG	B
SCALE:	NTS	U.O.M.: INCHES	SHEET: 1 OF 1