

TOSHIBA PHOTOCOUPLER GaAs IRED & PHOTO-TRIAC

TLP3061F(S), TLP3062F(S), TLP3063F(S)

Office Machines
Home Appliances
Triac Drivers
Solid State Relays

The TOSHIBA TLP3061F(S), TLP3062F(S) and TLP3063F(S) of a gallium arsenide infrared emitting diode optically coupled to a triac-output photocoupler featuring a zero-cross voltage and is housed in a six-lead plastic DIP package. All parameters are tested to the specification of the TLP3061(S) TLP3062(S) and TLP3063(S), including test conditions and ratings.

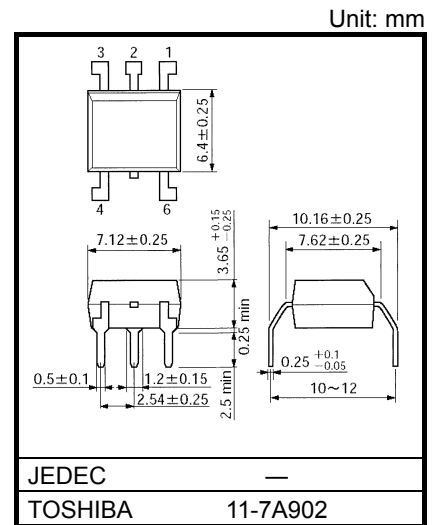

Weight: 0.39 g (typ.)

- Peak Off-state voltage: 600 V (min)
- Trigger LED current: 15 mA (max) (TLP3061F(S))
10 mA (max) (TLP3062F(S))
5 mA (max) (TLP3063F(S))
- On-state current: 100 mA (max)
- Isolation voltage: 5000 Vrms (min)
- UL recognized: UL1577, File No. E67349
- SEMKO approved: EN60065
EN60950-1
EN60335-1, File No.712796
- BSI Approved: BS EN60065:2002, File No.8385
BS EN60950-1:2006, File No.8386
- Option (D4) type
VDE approved: DIN EN60747-5-2
Approved No. 40009302
Maximum operating insulation voltage: 1140 VPK
Maximum permissible overvoltage: 8000 VPK

Note: When ordering an EN60747-5-2 approved device, "Option (D4)" should be designated.

	10.16 mm pitch TLPxxxxF type
Creepage Distance	8.0 mm (min)
Clearance	8.0 mm (min)
Insulation Thickness	0.5 mm (min)

Pin Configuration (top view)

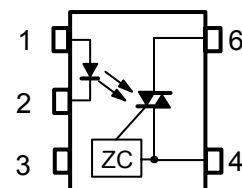

- 1: Anode
- 2: Cathode
- 3: N.C.
- 4: Terminal 1
- 6: Terminal 2

ZC: Zero-cross Circuit

RESTRICTIONS ON PRODUCT USE

20070701-EN GENERAL

- The information contained herein is subject to change without notice.
- TOSHIBA is continually working to improve the quality and reliability of its products. Nevertheless, semiconductor devices in general can malfunction or fail due to their inherent electrical sensitivity and vulnerability to physical stress. It is the responsibility of the buyer, when utilizing TOSHIBA products, to comply with the standards of safety in making a safe design for the entire system, and to avoid situations in which a malfunction or failure of such TOSHIBA products could cause loss of human life, bodily injury or damage to property.
In developing your designs, please ensure that TOSHIBA products are used within specified operating ranges as set forth in the most recent TOSHIBA products specifications. Also, please keep in mind the precautions and conditions set forth in the "Handling Guide for Semiconductor Devices," or "TOSHIBA Semiconductor Reliability Handbook" etc.
- The TOSHIBA products listed in this document are intended for usage in general electronics applications (computer, personal equipment, office equipment, measuring equipment, industrial robotics, domestic appliances, etc.). These TOSHIBA products are neither intended nor warranted for usage in equipment that requires extraordinarily high quality and/or reliability or a malfunction or failure of which may cause loss of human life or bodily injury ("Unintended Usage"). Unintended Usage include atomic energy control instruments, airplane or spaceship instruments, transportation instruments, traffic signal instruments, combustion control instruments, medical instruments, all types of safety devices, etc.. Unintended Usage of TOSHIBA products listed in this document shall be made at the customer's own risk.
- The products described in this document shall not be used or embedded to any downstream products of which manufacture, use and/or sale are prohibited under any applicable laws and regulations.
- The information contained herein is presented only as a guide for the applications of our products. No responsibility is assumed by TOSHIBA for any infringements of patents or other rights of the third parties which may result from its use. No license is granted by implication or otherwise under any patents or other rights of TOSHIBA or the third parties.
- GaAs(Gallium Arsenide) is used in this product. The dust or vapor is harmful to the human body. Do not break, cut, crush or dissolve chemically.
- Please contact your sales representative for product-by-product details in this document regarding RoHS compatibility. Please use these products in this document in compliance with all applicable laws and regulations that regulate the inclusion or use of controlled substances. Toshiba assumes no liability for damage or losses occurring as a result of noncompliance with applicable laws and regulations.