



SPECIFICATION OF EFM-940L

ELECTRICAL SPECIFICATIONS:

Part Number		EFM-940L
Min. Sound Pressure Level	(dB)	70/ 12V _{DC} / 30cm
Rated Voltage	(V _{DC})	12
Oscillating Frequency	(kHz)	3.1 ± 0.5
Max. Consumption	(mA)	8/12V _{DC}
Operating Temperature	(°C)	-20 ~ +70
Storage Temperature	(°C)	-30 ~ +80
Weight	(g)	3
Case Material/Color		PC/Black

DIMENSIONS(unit: mm):

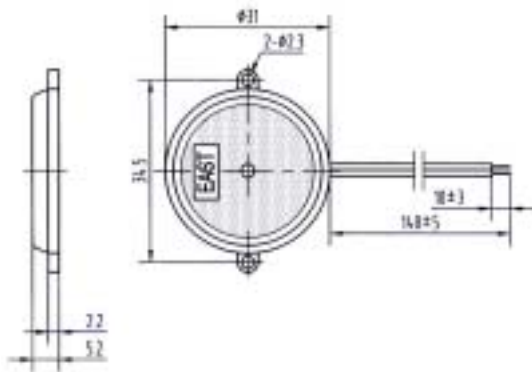

CHARACTERISTICS:

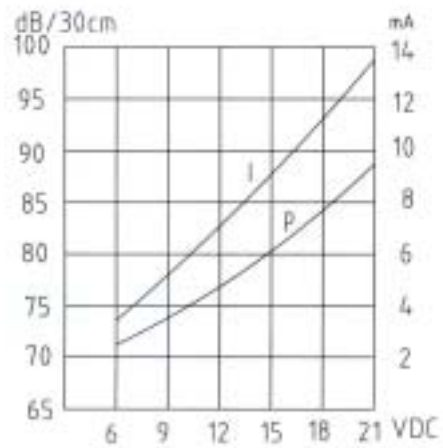

Address: NO. 12 , Lane 722 , Sangtian Road, Jiangdong Science Garden Ningbo, China

Tel: (0574)87802511

P.C: 315040

Fax:(0574)87803761

