

**AUTOMOTIVE GRADE 1.24V SHUNT REGULATOR**

**Description**

The TLV431Q is a three terminal adjustable shunt regulator offering excellent temperature stability and output current handling capability up to 20mA. The output voltage may be set to any chosen voltage between 1.24 and 18 volts by selection of two external divider resistors.

The TLV431Q can be used as a replacement for zener diodes in many applications requiring an improvement in zener performance.

The TLV431Q is available in 3 grades with initial tolerances of 1%, 0.5%, and 0.2% for the A, B and T grades respectively.

The TLV431Q has been qualified to AEC-Q100 Grade 1 and is Automotive Grade supporting PPAPs

**Features**

- Low Voltage Operation  $V_{REF} = 1.24V$
- Temperature range  $-40$  to  $+125^{\circ}C$
- Reference Voltage Tolerance at  $+25^{\circ}C$ 
  - 0.2% TLV431TQ
  - 0.5% TLV431BQ
  - 1% TLV431AQ
- Typical temperature drift
  - 4 mV ( $0^{\circ}C$  to  $+70^{\circ}C$ )
  - 6 mV ( $-40^{\circ}C$  to  $+85^{\circ}C$ )
  - 11mV ( $-40^{\circ}C$  to  $+125^{\circ}C$ )
- 80 $\mu$ A Minimum cathode current
- 0.25 $\Omega$  Typical Output Impedance
- Adjustable Output Voltage  $V_{REF}$  to 18V
- Green Molding
  - Totally Lead-Free & Fully RoHS Compliant (Notes 1 & 2)
  - Halogen and Antimony Free. "Green" Device (Note 3)
- **Automotive Grade**
  - Qualified to AEC-Q100 Grade 1
  - Supports PPAP documents

**Pin Assignments**

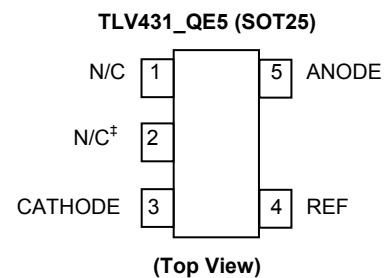
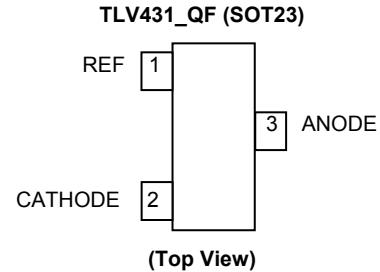

‡ Pin should be left floating or connect to anode

**Typical Application Circuit**

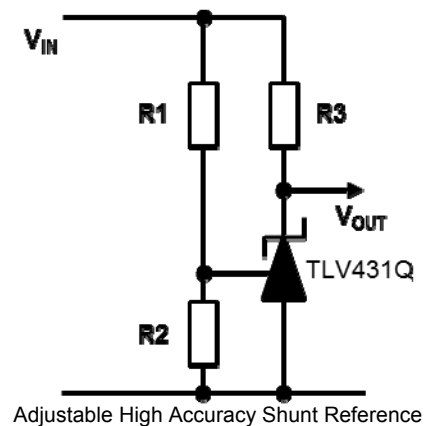

Notes: 1. EU Directive 2002/95/EC (RoHS) & 2011/65/EU (RoHS 2) compliant. All applicable RoHS exemptions applied.  
 2. See <http://www.diodes.com> for more information about Diodes Incorporated's definitions of Halogen- and Antimony-free, "Green" and Lead-free.  
 3. Halogen- and Antimony-free "Green" products are defined as those which contain <900ppm bromine, <900ppm chlorine (<1500ppm total Br + Cl) and <1000ppm antimony compounds.  
 4. Automotive products are AEC-Q10x qualified and are PPAP capable. Automotive, AEC-Q10x and standard products are electrically and thermally the same, except where specified. For more information, please refer to [http://www.diodes.com/quality/product\\_compliance\\_definitions/](http://www.diodes.com/quality/product_compliance_definitions/).

### Absolute Maximum Ratings (@ $T_A = +25^\circ\text{C}$ , unless otherwise specified.)

Symbol	Parameter	Rating	Unit
$V_{KA}$	Cathode Voltage	20	V
$I_{KA}$	Continuous Cathode Current	-20 to +20	mA
$I_{REF}$	Reference Input Current Range	-0.05 to +3	mA
$V_{IN}$	Input Supply Voltage (Relative to Ground)	-0.03 to +18	V
<b>ESD Susceptibility</b>			
HBM	Human Body Model	4	kV
MM	Machine Model	400	V
CDM	Charged Device Model	1	kV

(Semiconductor devices are ESD sensitive and may be damaged by exposure to ESD events. Suitable ESD precautions should be taken when handling and transporting these devices.)

Parameter	Rating	Unit
Operating Junction Temperature	-40 to +150	$^\circ\text{C}$
Storage Temperature	-65 to +150	$^\circ\text{C}$

Operation above the absolute maximum rating may cause device failure.

Operation at the absolute maximum ratings, for extended periods, may reduce device reliability.

Unless otherwise stated voltages specified are relative to the ANODE pin.

These are stress ratings only. Operation outside the absolute maximum ratings may cause device failure.

### Recommended Operating Conditions (@ $T_A = +25^\circ\text{C}$ , unless otherwise specified.)

Symbol	Parameter	Min	Max	Units
$V_{KA}$	Cathode Voltage	$V_{REF}$	18	V
$I_{KA}$	Cathode Current	0.1	15	mA
$T_A$	Operating Ambient Temperature Range	-40	+125	$^\circ\text{C}$

### Package Thermal Data

Package	$\theta_{JA}$	$P_{DIS}$ $T_A = +25^\circ\text{C}, T_J = +150^\circ\text{C}$
SOT23	380 $^\circ\text{C}/\text{W}$	330mW
SOT25	250 $^\circ\text{C}/\text{W}$	500mW

### Electrical Characteristics (@ $T_A = +25^\circ\text{C}$ , unless otherwise specified.)

Symbol	Parameter	Conditions	Min	Typ	Max	Units	
V <sub>REF</sub>	Reference Voltage	V <sub>KA</sub> = V <sub>REF</sub> , T <sub>A</sub> = +25°C	TLV431AQ	1.228	1.24	1.252	V
			TLV431BQ	1.234	1.24	1.246	
			TLV431TQ	1.2375	1.24	1.2425	
		V <sub>KA</sub> = V <sub>REF</sub> , T <sub>A</sub> = 0 to +70°C	TLV431AQ	1.221	—	1.259	
			TLV431BQ	1.227	—	1.253	
			TLV431TQ	1.230	—	1.250	
		V <sub>KA</sub> = V <sub>REF</sub> , T <sub>A</sub> = -40 to +85°C	TLV431AQ	1.215	—	1.265	
			TLV431BQ	1.224	—	1.259	
			TLV431TQ	1.228	—	1.252	
		V <sub>KA</sub> = V <sub>REF</sub> , T <sub>A</sub> = -40 to +125°C	TLV431AQ	1.209	—	1.271	
			TLV431BQ	1.221	—	1.265	
			TLV431TQ	1.224	—	1.255	
V <sub>REF(dev)</sub>	Deviation of reference voltage over full temperature range	V <sub>KA</sub> = V <sub>REF</sub>	T <sub>A</sub> = 0 to +70°C	—	4	12	mV
			T <sub>A</sub> = -40 to +85°C	—	6	20	
			T <sub>A</sub> = -40 to +125°C	—	11	31	
$\frac{\Delta V_{REF}}{\Delta V_{KA}}$	Ratio of change in reference voltage to the change in cathode voltage	V <sub>KA</sub> for V <sub>REF</sub> to	6V	—	-1.5	-2.7	mV/V
			18V	—	-1.5	-2.7	
I <sub>REF</sub>	Reference Input Current	R <sub>1</sub> = 10kΩ, R <sub>2</sub> = OC	—	0.15	0.5	μA	
I <sub>REF(dev)</sub>	I <sub>REF</sub> deviation over full temperature range	R <sub>1</sub> = 10kΩ, R <sub>2</sub> = OC	T <sub>A</sub> = 0 to +70°C	—	0.05	0.3	μA
			T <sub>A</sub> = -40 to +85°C	—	0.1	0.4	
			T <sub>A</sub> = -40 to +125°C	—	0.15	0.5	
I <sub>KMIN</sub>	Minimum cathode current for regulation	V <sub>KA</sub> = V <sub>REF</sub>	T <sub>A</sub> = 0 to +70°C	—	55	80	μA
			T <sub>A</sub> = -40 to +85°C	—	55	80	
			T <sub>A</sub> = -40 to +125°C	—	55	100	
I <sub>K(OFF)</sub>	Off state current	V <sub>KA</sub> = 18V, V <sub>REF</sub> = 0V	—	0.001	0.1	μA	
Z <sub>KA</sub>	Dynamic output impedance	V <sub>KA</sub> = V <sub>REF</sub> , f = <1kHz I <sub>K</sub> = 0.1 to 15Ma	—	0.25	0.4	Ω	

**Typical Characteristics**

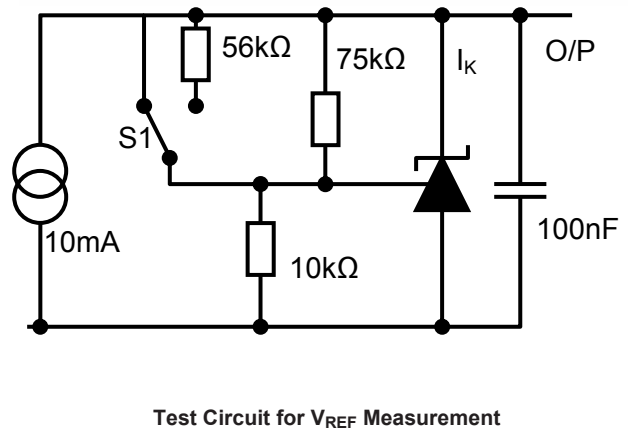
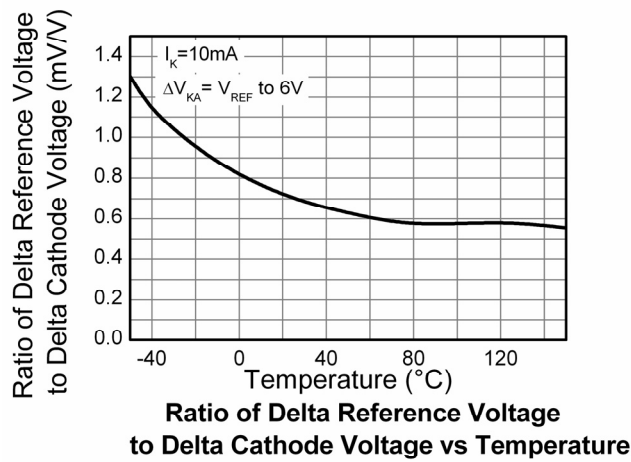
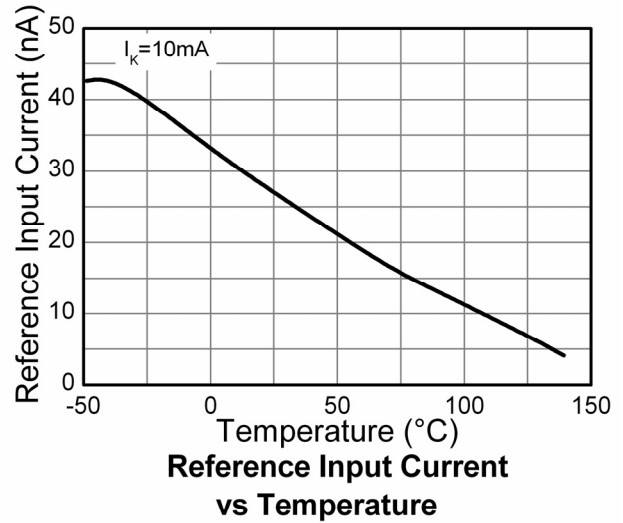
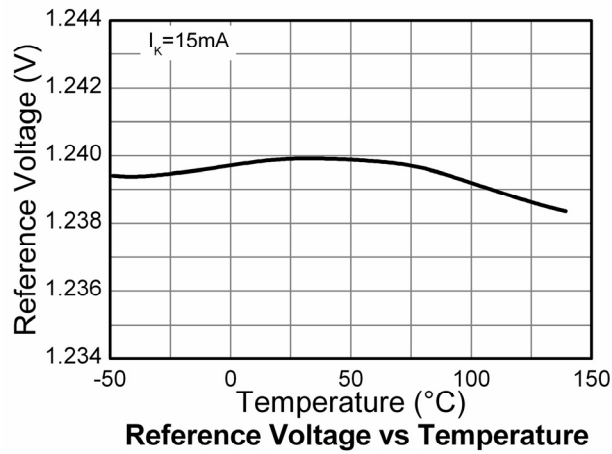

**Typical Characteristics** (cont.)

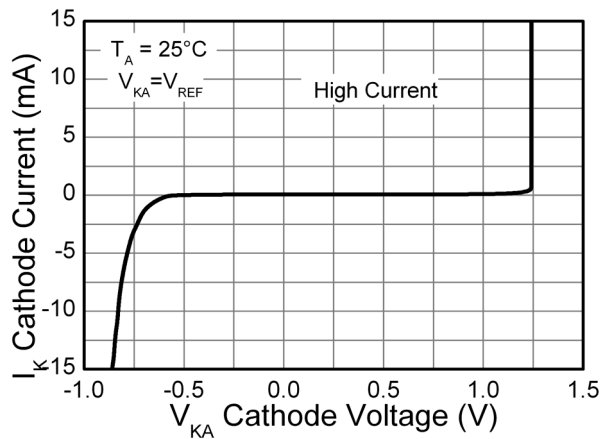

**Cathode Current vs Voltage**

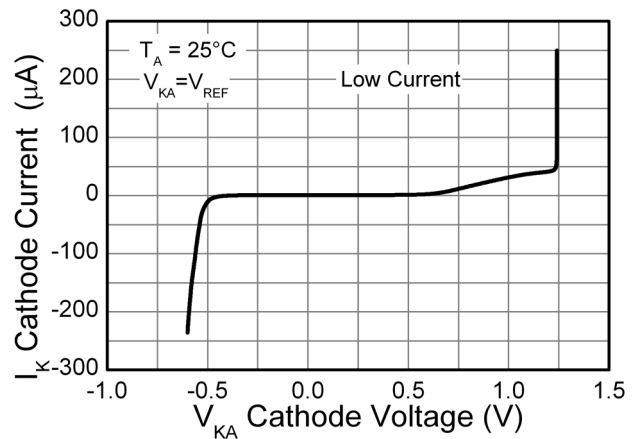

**Cathode Current vs Voltage**

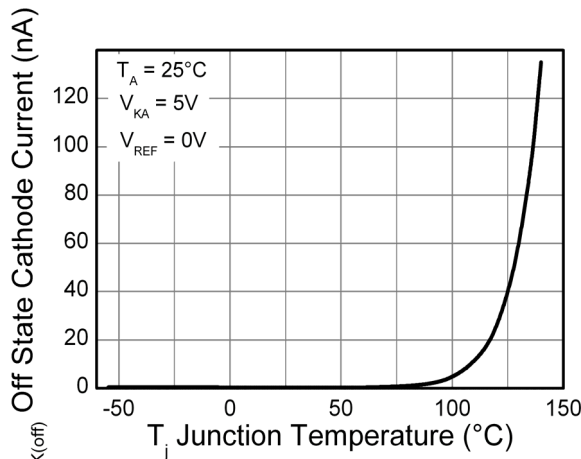

**Off-State Current vs Junction Temperature**

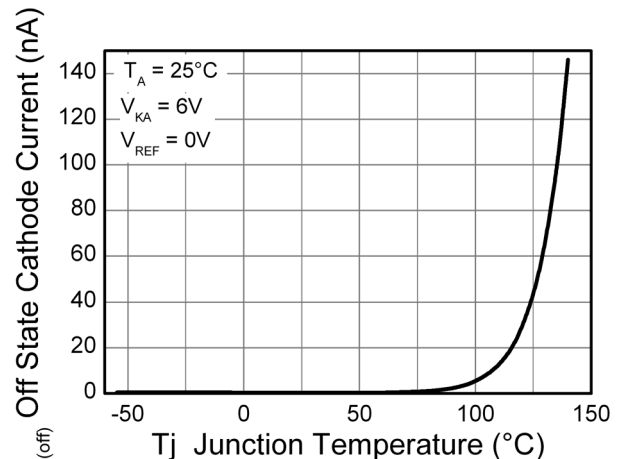

**Off-State Current vs Junction Temperature**

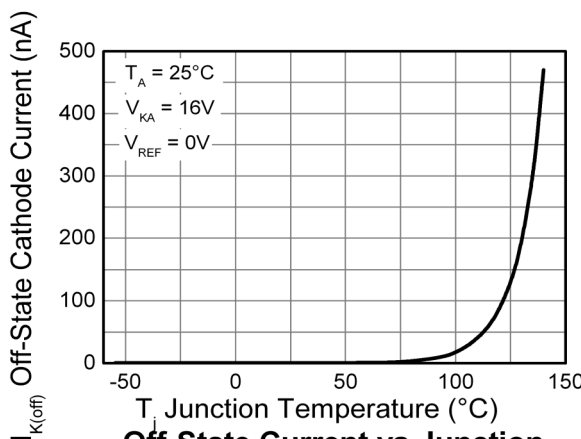

**Off-State Current vs Junction Temperature**

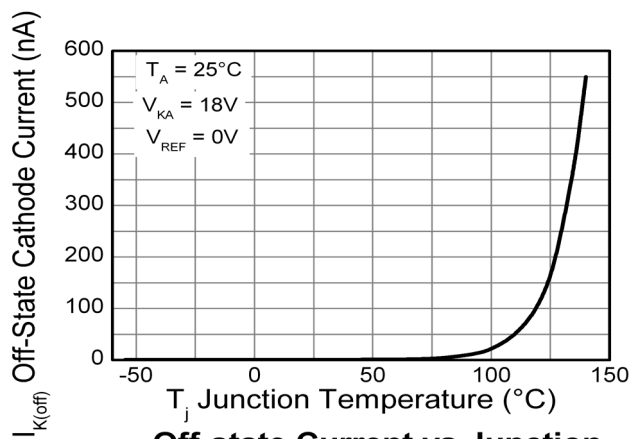

**Off-state Current vs Junction Temperature**

**Typical Characteristics (cont.)**

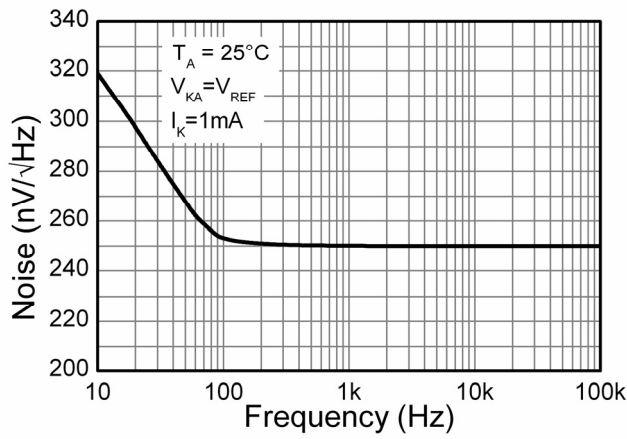

**Equivalent Input Noise Voltage vs Frequency**

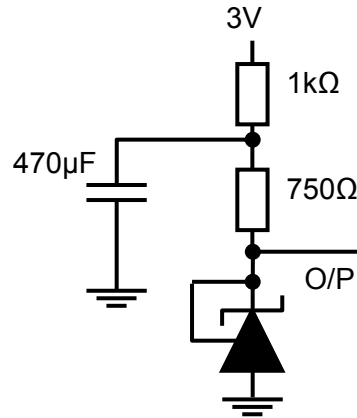

**Test Circuit for Input Noise Voltage**

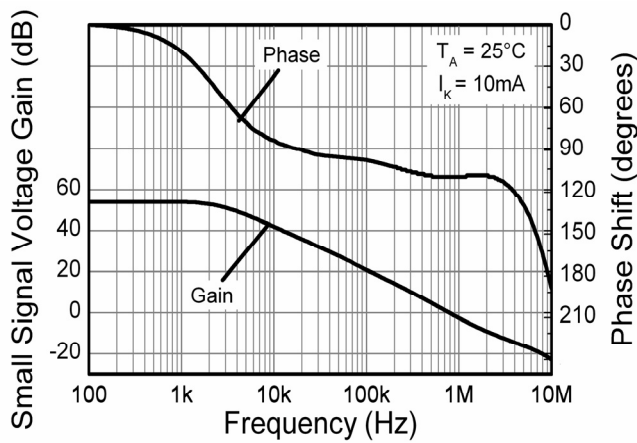

**Phase Shift and Gain vs Frequency**

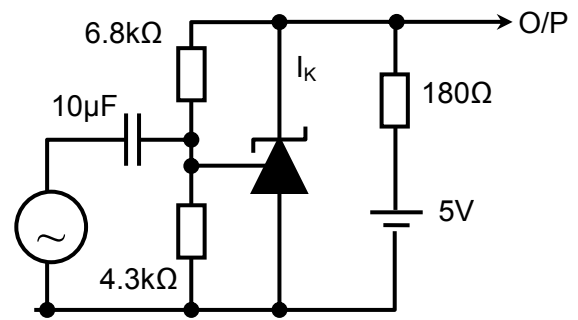

**Test Circuit for Phase Shift and Gain**

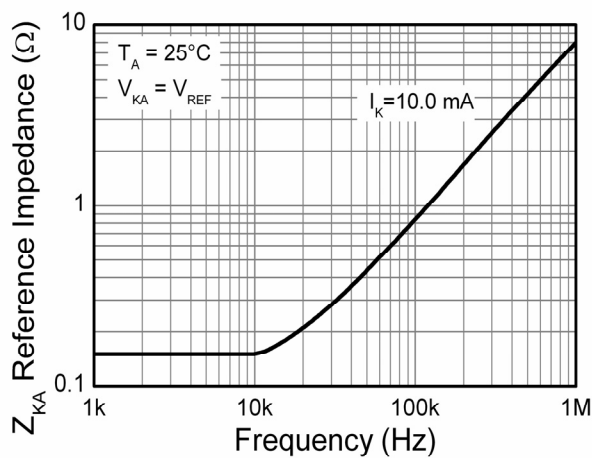

**Reference Impedance vs Frequency**

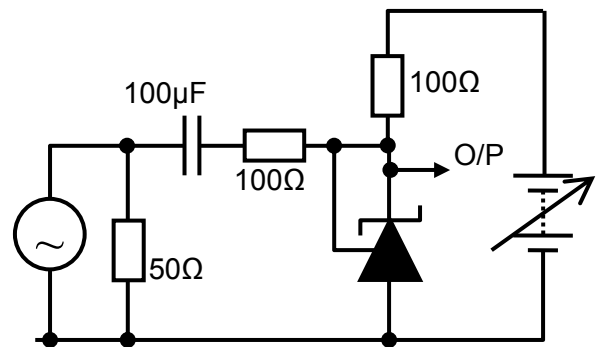

**Test Circuit for Reference Impedance**

**Typical Characteristics (cont.)**

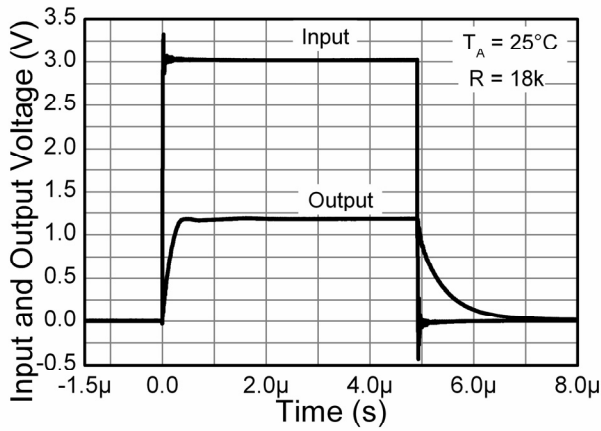

**Pulse Response**

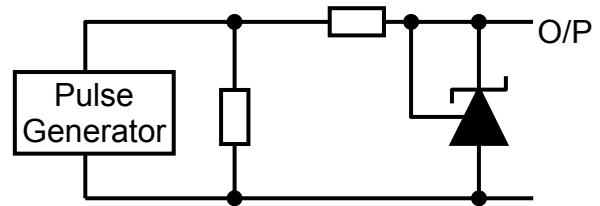

**Test Circuit for Pulse Response**

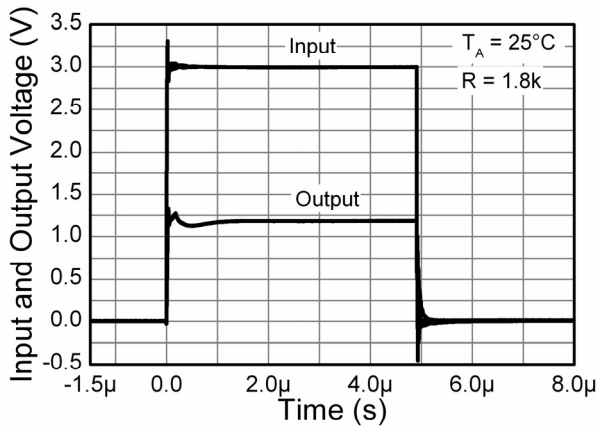

**Pulse Response**

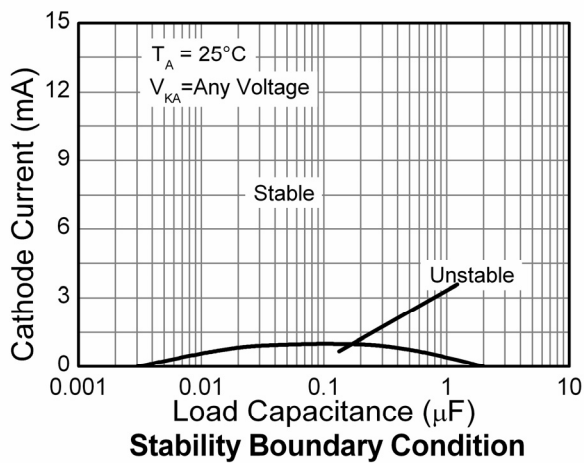

**Stability Boundary Condition**

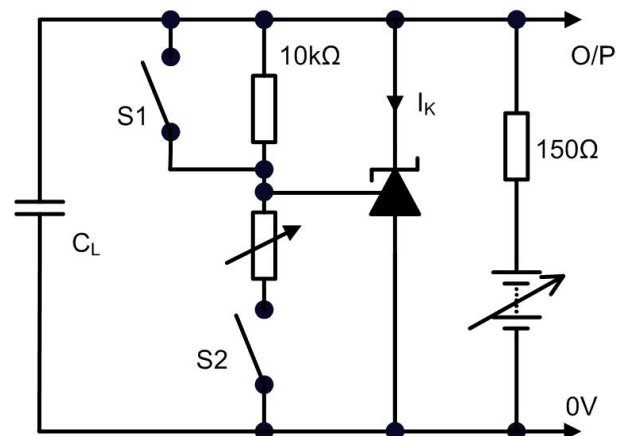

**Application Notes**

In a conventional shunt regulator application (Figure 1), an external series resistor ( $R_3$ ) is connected between the supply voltage,  $V_{IN}$ , and the TLV431Q. The 0.5% and 0.2% tolerance versions allow the creation of a high accuracy adjustable shunt reference.

$R_3$  determines the current that flows through the load ( $I_L$ ) and the TLV431Q ( $I_K$ ). The TLV431Q will adjust how much current it sinks or “shunts” to maintain a voltage equal to  $V_{REF}$  across its feedback pin. Since load current and supply voltage may vary,  $R_3$  should be small enough to supply at least the minimum acceptable  $I_{KMIN}$  to the TLV431Q even when the supply voltage is at its minimum and the load current is at its maximum value. When the supply voltage is at its maximum and  $I_L$  is at its minimum,  $R_3$  should be large enough so that the current flowing through the TLV431Q is less than 15mA.

$R_3$  is determined by the supply voltage, ( $V_{IN}$ ), the load and operating current, ( $I_L$  and  $I_K$ ), and the TLV431Q’s reverse breakdown voltage,  $V_{KA}$ .

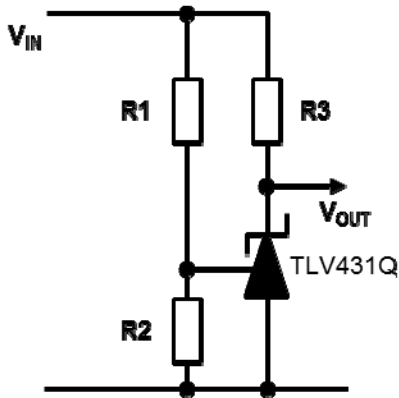

Figure 1. Adjustable low voltage reference

$$R_3 = \frac{V_{IN} - V_{KA}}{I_L + I_K}$$

where

$$V_{KA} = V_{REF} \times \left( 1 + \frac{R_1}{R_2} \right)$$

and  $V_{KA} = V_{OUT}$

The values of  $R_1$  and  $R_2$  should be large enough so that the current flowing through them is much smaller than the current through  $R_3$  yet not too large so that the voltage drop across them caused by  $I_{REF}$  affects the reference accuracy.

**Printed Circuit Board Layout Considerations**

The TLV431Q in the SOT25 package has the die attached to pin 2, which results in an electrical contact between pin 2 and pin 5. Therefore, pin 2 of the SOT25 package must be left floating or connected to pin 5.

**Other Applications of the TLV431Q**

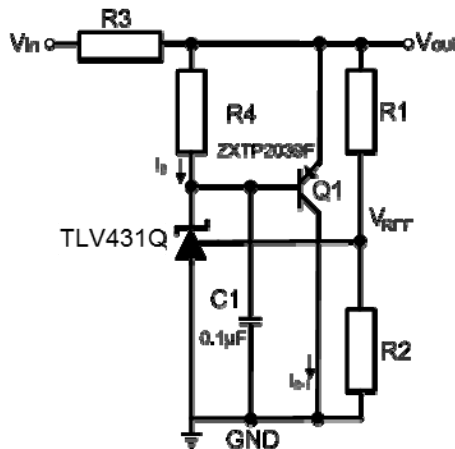

Figure 2. High Current Shunt Regulator

$$V_{OUT} = V_{REF} \left( 1 + \frac{R_1}{R_2} \right)$$

$$R_3 = \frac{V_{IN} - V_{OUT}}{I_{SH} + I_B}$$

$$R_4 = \frac{V_{BE}}{I_B}$$

$$\left( \frac{I_{SH}}{h_{FE(min)}} \right) < I_B \leq 15mA$$

It may at times be required to shunt-regulate more current than the 15mA that the TLV431Q is capable of.

Figure 2 shows how this can be done using transistor Q1 to amplify the TLV431Q’s current. Care needs to be taken that the power dissipation and/or SOA requirements of the transistor is not exceeded.



**Application Notes** (cont.)

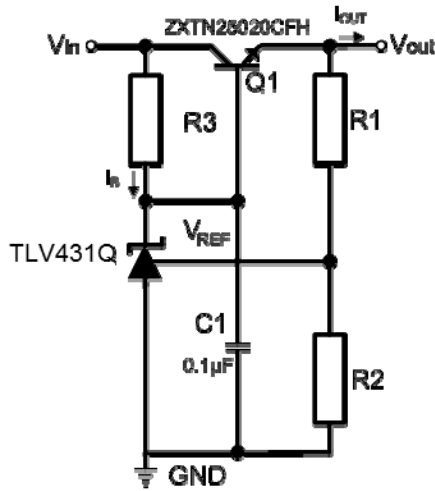

$$V_{OUT} = V_{REF} \left( 1 + \frac{R1}{R2} \right)$$

$$R3 = \frac{V_{IN} - (V_{OUT} + V_{BE})}{I_B}$$

$$\left( \frac{I_{OUT(max)}}{h_{FE(min)}} \right) < I_B \leq 15mA$$

**Figure 3. Basic Series Regulator**

A very effective and simple series regulator can be implemented as shown in Figure 3 above. This may be preferable if the load requires more current than can be provided by the TLV431Q alone and there is a need to conserve power when the load is not being powered. This circuit also uses one component less than the shunt circuit shown in Figure 3 above.

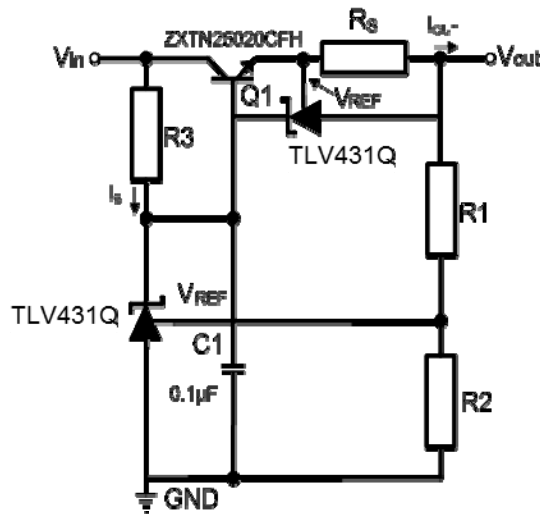

$$V_{OUT} = V_{REF} \left( 1 + \frac{R1}{R2} \right)$$

$$R3 = \frac{V_{IN} - (V_{OUT} + V_{BE})}{I_B}$$

$$\left( \frac{I_{OUT(max)}}{h_{FE(min)}} \right) < I_B \leq 18mA$$

$$R_S = \frac{V_{REF}}{I_{OUT(max)}}$$

**Figure 4. Series Regulator with Current Limit**

Figure 4 adds current limit to the series regulator in Figure 3 using a second TLV431Q. For currents below the limit, the circuit works normally supplying the required load current at the design voltage. However should attempts be made to exceed the design current set by the second TLV431Q, the device begins to shunt current away from the base of Q1. This begins to reduce the output voltage and thus ensuring that the output current is clamped at the design value. Subject only to Q1's ability to withstand the resulting power dissipation, the circuit can withstand either a brief or indefinite short circuit.

**Application Notes** (cont.)

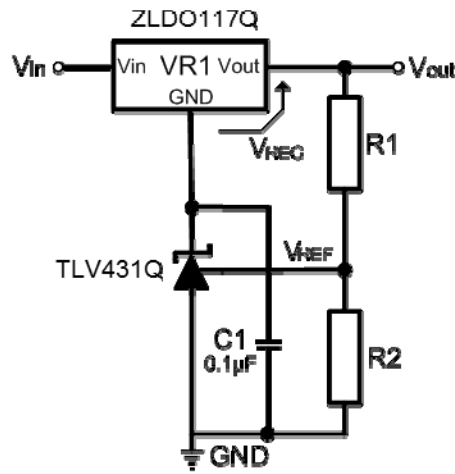

$$V_{OUT} = V_{REF} \left( 1 + \frac{R1}{R2} \right)$$

$$V_{OUT} \geq (V_{REG} + V_{REF})$$

(All features of the regulator such as short circuit protection, thermal shutdown, etc, are maintained.)

**Figure 5. Increasing Output Voltage of a Fixed Linear Regulator**

One of the useful applications of the TLV431Q is in using it to improve the accuracy and/or extend the range and flexibility of fixed voltage regulators. In the circuit in Figure 5 above both the output voltage and its accuracy are entirely determined by the TLV431Q, R1 and R2. However the rest of the features of the regulator (up to 1A output current, output current limiting and thermal shutdown) are all still available.

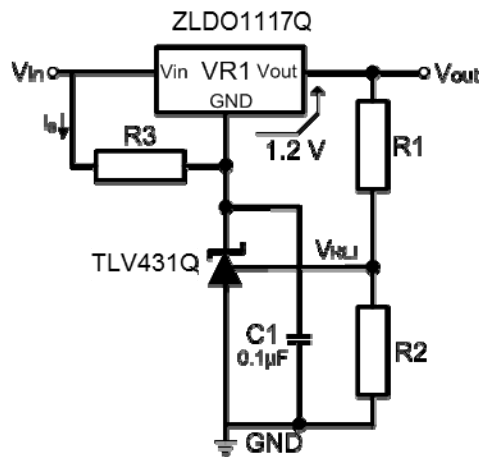

$$V_{OUT} = V_{REF} \left( 1 + \frac{R1}{R2} \right)$$

$$V_{OUT} \geq (V_{REG} + V_{REF})$$

$$R3 = \frac{V_{IN} - (V_{OUT} - V_{REG})}{I_B}$$

$$0.1\text{mA} \leq I_B \leq 18\text{mA}$$

(All features of the regulator such as short circuit protection, thermal shutdown, etc, are maintained.)

**Figure 6. Adjustable Linear Voltage Regulator**

Figure 6 is similar to Figure 5 with adjustability added. Note the addition of R3, This is added to provide sufficient bias current for the TLV431Q.

**Ordering Information**

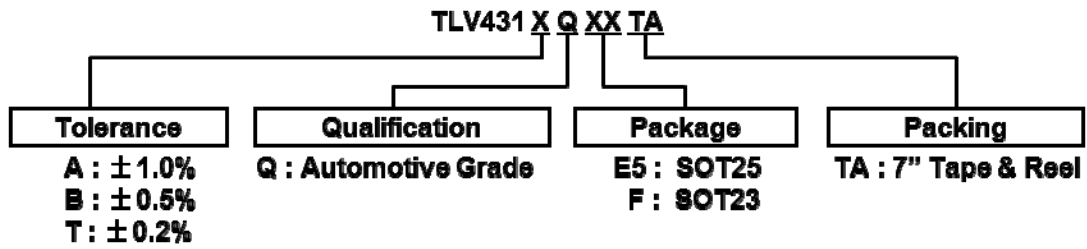

Tol.	Part Number	Package	Part Mark	Status	Reel Size	Tape Width	Quantity per Reel
1%	TLV431AQE5TA	SOT25	V1A	Active	7", 180mm	8mm	3000
	TLV431AQFTA	SOT23	V1A	Active	7", 180mm	8mm	3000
0.5%	TLV431BQE5TA	SOT25	V1B	Active	7", 180mm	8mm	3000
	TLV431BQFTA	SOT23	V1B	Active	7", 180mm	8mm	3000
0.2%	TLV431TQFTA	SOT23	V1T	Active	7", 180mm	8mm	3000

**Package Outline Dimensions** (All dimensions in mm.)

Please see AP02002 at <http://www.diodes.com/datasheets/ap02002.pdf> for latest version.

**SOT23**

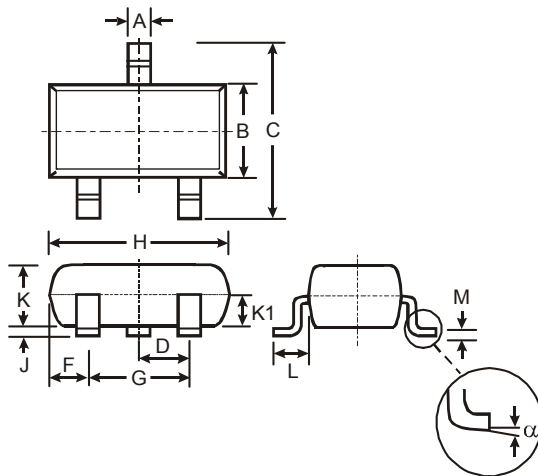

SOT23			
Dim	Min	Max	Typ
A	0.37	0.51	0.40
B	1.20	1.40	1.30
C	2.30	2.50	2.40
D	0.89	1.03	0.915
F	0.45	0.60	0.535
G	1.78	2.05	1.83
H	2.80	3.00	2.90
J	0.013	0.10	0.05
K	0.903	1.10	1.00
K1	—	—	0.400
L	0.45	0.61	0.55
M	0.085	0.18	0.11
α	0°	8°	—
All Dimensions in mm			

**SOT25**

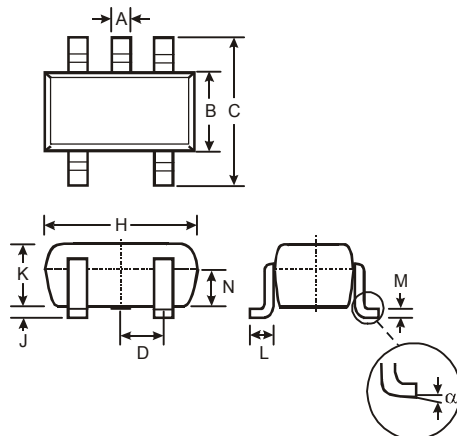

SOT25			
Dim	Min	Max	Typ
A	0.35	0.50	0.38
B	1.50	1.70	1.60
C	2.70	3.00	2.80
D	—	—	0.95
H	2.90	3.10	3.00
J	0.013	0.10	0.05
K	1.00	1.30	1.10
L	0.35	0.55	0.40
M	0.10	0.20	0.15
N	0.70	0.80	0.75
α	0°	8°	—
All Dimensions in mm			

**Suggested Pad Layout**

Please see AP02001 at <http://www.diodes.com/datasheets/ap02001.pdf> for the latest version.

**SOT23**

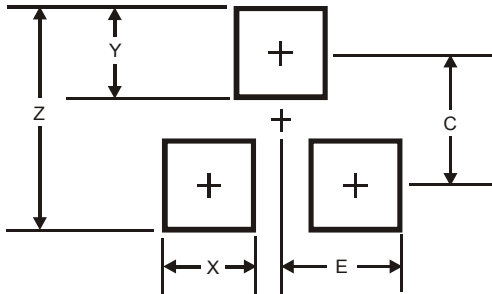

Dimensions	Value (in mm)
Z	2.9
X	0.8
Y	0.9
C	2.0
E	1.35

**SOT25**

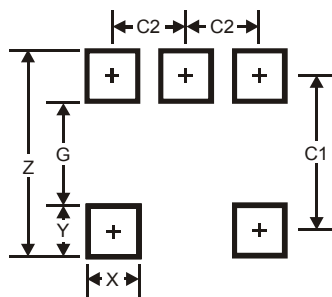

Dimensions	Value (in mm)
Z	3.20
G	1.60
X	0.55
Y	0.80
C1	2.40
C2	0.95

**IMPORTANT NOTICE**

DIODES INCORPORATED MAKES NO WARRANTY OF ANY KIND, EXPRESS OR IMPLIED, WITH REGARDS TO THIS DOCUMENT, INCLUDING, BUT NOT LIMITED TO, THE IMPLIED WARRANTIES OF MERCHANTABILITY AND FITNESS FOR A PARTICULAR PURPOSE (AND THEIR EQUIVALENTS UNDER THE LAWS OF ANY JURISDICTION).

Diodes Incorporated and its subsidiaries reserve the right to make modifications, enhancements, improvements, corrections or other changes without further notice to this document and any product described herein. Diodes Incorporated does not assume any liability arising out of the application or use of this document or any product described herein; neither does Diodes Incorporated convey any license under its patent or trademark rights, nor the rights of others. Any Customer or user of this document or products described herein in such applications shall assume all risks of such use and will agree to hold Diodes Incorporated and all the companies whose products are represented on Diodes Incorporated website, harmless against all damages.

Diodes Incorporated does not warrant or accept any liability whatsoever in respect of any products purchased through unauthorized sales channel. Should Customers purchase or use Diodes Incorporated products for any unintended or unauthorized application, Customers shall indemnify and hold Diodes Incorporated and its representatives harmless against all claims, damages, expenses, and attorney fees arising out of, directly or indirectly, any claim of personal injury or death associated with such unintended or unauthorized application.

Products described herein may be covered by one or more United States, international or foreign patents pending. Product names and markings noted herein may also be covered by one or more United States, international or foreign trademarks.

**LIFE SUPPORT**

Diodes Incorporated products are specifically not authorized for use as critical components in life support devices or systems without the express written approval of the Chief Executive Officer of Diodes Incorporated. As used herein:

A. Life support devices or systems are devices or systems which:

1. are intended to implant into the body, or
2. support or sustain life and whose failure to perform when properly used in accordance with instructions for use provided in the labeling can be reasonably expected to result in significant injury to the user.

B. A critical component is any component in a life support device or system whose failure to perform can be reasonably expected to cause the failure of the life support device or to affect its safety or effectiveness.

Customers represent that they have all necessary expertise in the safety and regulatory ramifications of their life support devices or systems, and acknowledge and agree that they are solely responsible for all legal, regulatory and safety-related requirements concerning their products and any use of Diodes Incorporated products in such safety-critical, life support devices or systems, notwithstanding any devices- or systems-related information or support that may be provided by Diodes Incorporated. Further, Customers must fully indemnify Diodes Incorporated and its representatives against any damages arising out of the use of Diodes Incorporated products in such safety-critical, life support devices or systems.

Copyright © 2014, Diodes Incorporated

[www.diodes.com](http://www.diodes.com)