

Customer Information Sheet

DRAWING No.: M20-876XXXX

SHEET 2 OF 2

IF IN DOUBT - ASK

©

NOT TO SCALE

THIRD ANGLE PROJECTION

ALL DIMENSIONS IN mm

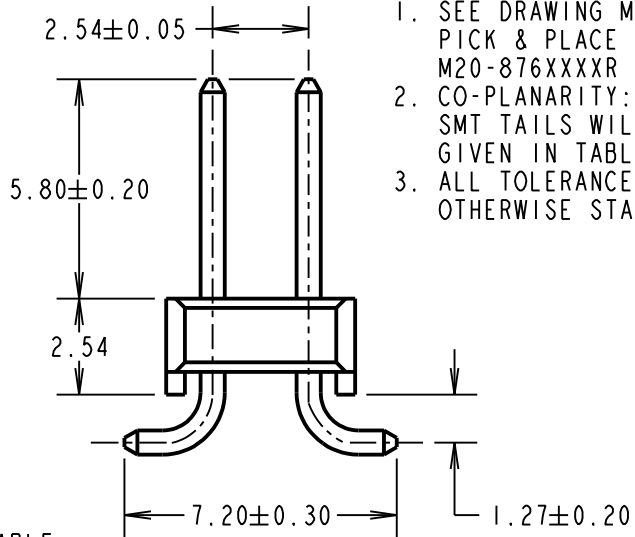
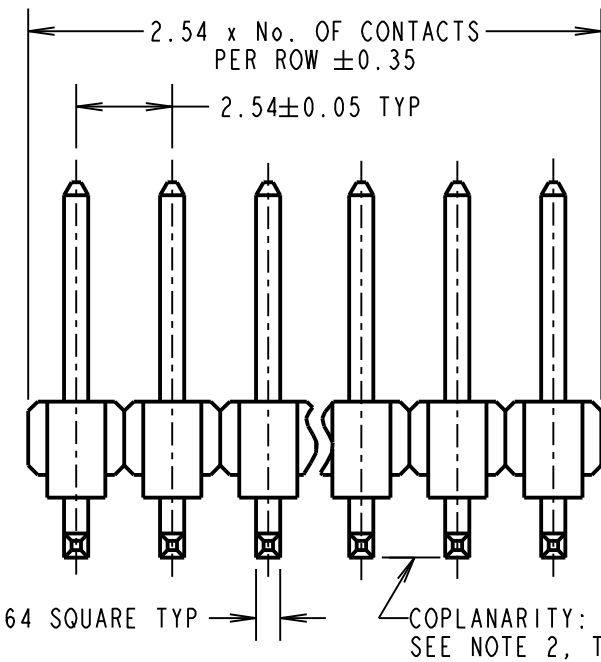
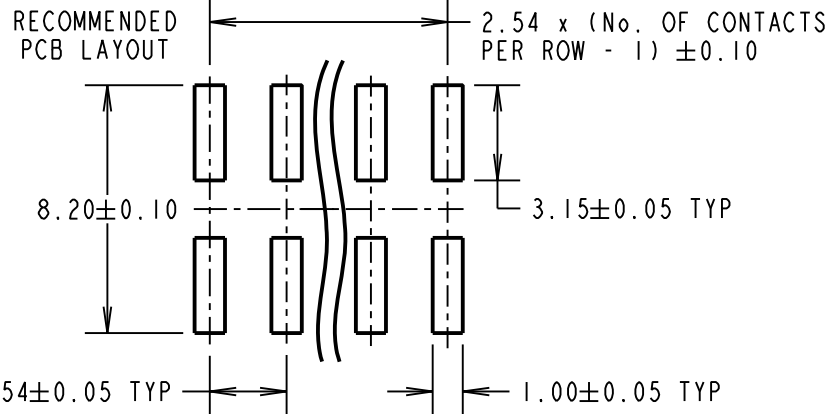
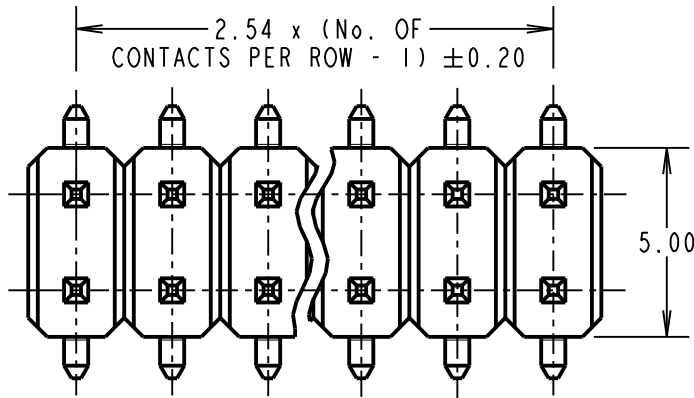

- NOTES:
1. SEE DRAWING M20-876XXXXP FOR PICK & PLACE IN TUBES, M20-876XXXXR FOR TAPE AND REELED.
 2. CO-PLANARITY: FLATNESS OF SMT TAILS WILL NOT EXCEED VALUES GIVEN IN TABLE.
 3. ALL TOLERANCES ARE ±0.15 UNLESS OTHERWISE STATED.

SPECIFICATION:
MATERIAL:
 MOULDING = PA6T UL94V-0, BLACK
 CONTACT = BRASS
FINISH (OVER NICKEL):
 42 = SELECTIVE GOLD ON CONTACT AREA, 100% TIN ON TAILS
 46 = 100% TIN
ELECTRICAL:
 CURRENT RATING = 3A MAX
 CONTACT RESISTANCE = 20mΩ MAX
 INSULATION RESISTANCE = 500MΩ MIN
 DIELECTRIC STRENGTH = 1000V AC
 VOLTAGE RATING = 250V AC/DC
MECHANICAL:
 DURABILITY = 50 OPERATIONS (TIN), 300 OPERATIONS (GOLD)
ENVIRONMENTAL:
 TEMPERATURE RANGE = -40°C TO +105°C
SOLDERING:
 REFLOW TEMP = 260°C FOR 10 SECONDS MAX
 MANUAL TEMP = 330°C FOR 3-5 SECONDS
PACKING:
 BAG
 FOR COMPLETE SPECIFICATION, SEE COMPONENT SPECIFICATION COOIXX (LATEST ISSUE)

No. OF CONTACTS PER ROW	COPLANARITY TOLERANCE
02 TO 12	0.10mm MAX
13 TO 20	0.15mm MAX
25, 36	0.20mm MAX

ORDER CODE:
M20-876XXXX
 No. OF CONTACTS PER ROW:
 02 TO 20, 25, 36
FINISH:
 42 = SELECTIVE GOLD + 100% TIN
 46 = 100% TIN

WJP	22	01.08.17	20398
NAME	ISS.	DATE	C/NOTE
APPROVED: W. J. PRESTON			
CHECKED: S. BENNETT			
DRAWN: P. D. COLLINS			
CUSTOMER REF.:			
ASSEMBLY DRG:			

HARWIN

www.harwin.com
 technical@harwin.com

THIS DRAWING AND ANY INFORMATION OR DESCRIPTIVE MATTER SET OUT HEREON ARE CONFIDENTIAL AND COPYRIGHT PROPERTY OF THE HARWIN GROUP AND MUST NOT BE DISCLOSED, LOANED, COPIED OR USED FOR MANUFACTURING, TENDERING OR FOR ANY OTHER PURPOSE WITHOUT THEIR WRITTEN PERMISSION.

TOLERANCES
~~X. = ±1mm~~
~~X.X = ±0.50mm~~
~~X.XX = ±0.10mm~~
~~X.XXX = ±0.01mm~~
 ANGLES = ±5°
 UNLESS STATED

MATERIAL:
 SEE ABOVE
FINISH:
 SEE ABOVE
S/AREA:
 mm²

TITLE:
 2.54mm PITCH DIL
 SMT PIN HEADER ASSEMBLY

DRAWING NUMBER:
M20-876XXXX

SHT
 2 OF 2