

## Features

- AEC-Q100 device qualification and full PPAP support available in both extended temperature Q-grade and I-grade.
- Guaranteed to meet full electrical specifications over  $T_A = -40^\circ\text{C}$  to  $+105^\circ\text{C}$  with  $T_J$  Maximum =  $+125^\circ\text{C}$  (Q-grade)
- 15.5 ns pin-to-pin logic delays
- System frequency up to 64.5 MHz
- 72 macrocells with 1,600 usable gates
- Available in small footprint packages
  - 44-pin VQFP (34 user I/O pins)
  - 64-pin VQFP (52 user I/O pins)
  - 100-pin TQFP (72 user I/O pins)
  - Pb-free package only
- Optimized for high-performance 3.3V systems
  - Low power operation
  - 5V tolerant I/O pins accept 5V, 3.3V, and 2.5V signals
  - 3.3V or 2.5V output capability
  - Advanced 0.35 micron feature size CMOS Fast FLASH™ technology
- Advanced system features
  - In-system programmable
  - Superior pin-locking and routability with Fast CONNECT™ II switch matrix
  - Extra wide 54-input Function Blocks
  - Up to 90 product-terms per macrocell with individual product-term allocation
  - Local clock inversion with three global and one product-term clocks
  - Individual output enable per output pin
  - Input hysteresis on all user and boundary-scan pin inputs
  - Bus-hold circuitry on all user pin inputs
  - Full IEEE Standard 1149.1 boundary-scan (JTAG)
- Fast concurrent programming
- Slew rate control on individual outputs
- Enhanced data security features
- Excellent quality and reliability
  - Endurance exceeding 10,000 program/erase cycles
  - 20 year data retention
  - ESD protection exceeding 2,000V

WARNING: Programming temperature range of  $T_A = 0^\circ\text{C}$  to  $+70^\circ\text{C}$

## Description

The XA9572XL is a 3.3V CPLD targeted for high-performance, low-voltage automotive applications. It is comprised of four 54V18 Function Blocks, providing 1,600 usable gates with propagation delays of 15.5 ns. See [Figure 2](#) for overview.

## Power Estimation

Power dissipation in CPLDs can vary substantially depending on the system frequency, design application and output loading. Each macrocell in an XA9500XL automotive device must be configured for low-power mode (default mode for XA9500XL devices). In addition, unused product-terms and macrocells are automatically deactivated by the software to further conserve power.

For a general estimate of  $I_{CC}$ , the following equation may be used:

$$I_{CC}(\text{mA}) = MC(0.052 \cdot PT + 0.272) + 0.04 \cdot MC_{TOG} \cdot MC \cdot f$$

where:

$MC$  = # macrocells

$PT$  = average number product terms per macrocell

$f$  = maximum clock frequency

$MC_{TOG}$  = average % of flip-flops toggling per clock (~12%)

This calculation was derived from laboratory measurements of an XA9500XL part filled with 16-bit counters and allowing a single output (the LSB) to be enabled. The actual  $I_{CC}$  value varies with the design application and should be verified during normal system operation. [Figure 1](#) shows the above estimation in a graphical form. For a more detailed discussion of power consumption in this device, see Xilinx application note [XAPP114, "Understanding XC9500XL CPLD Power."](#)

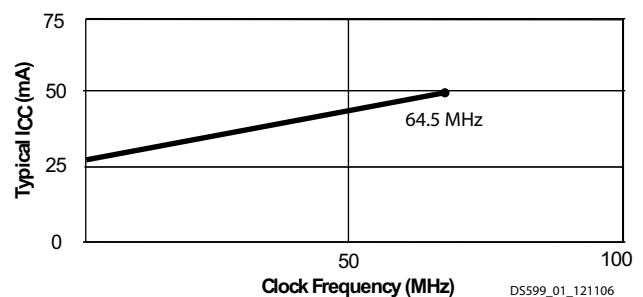
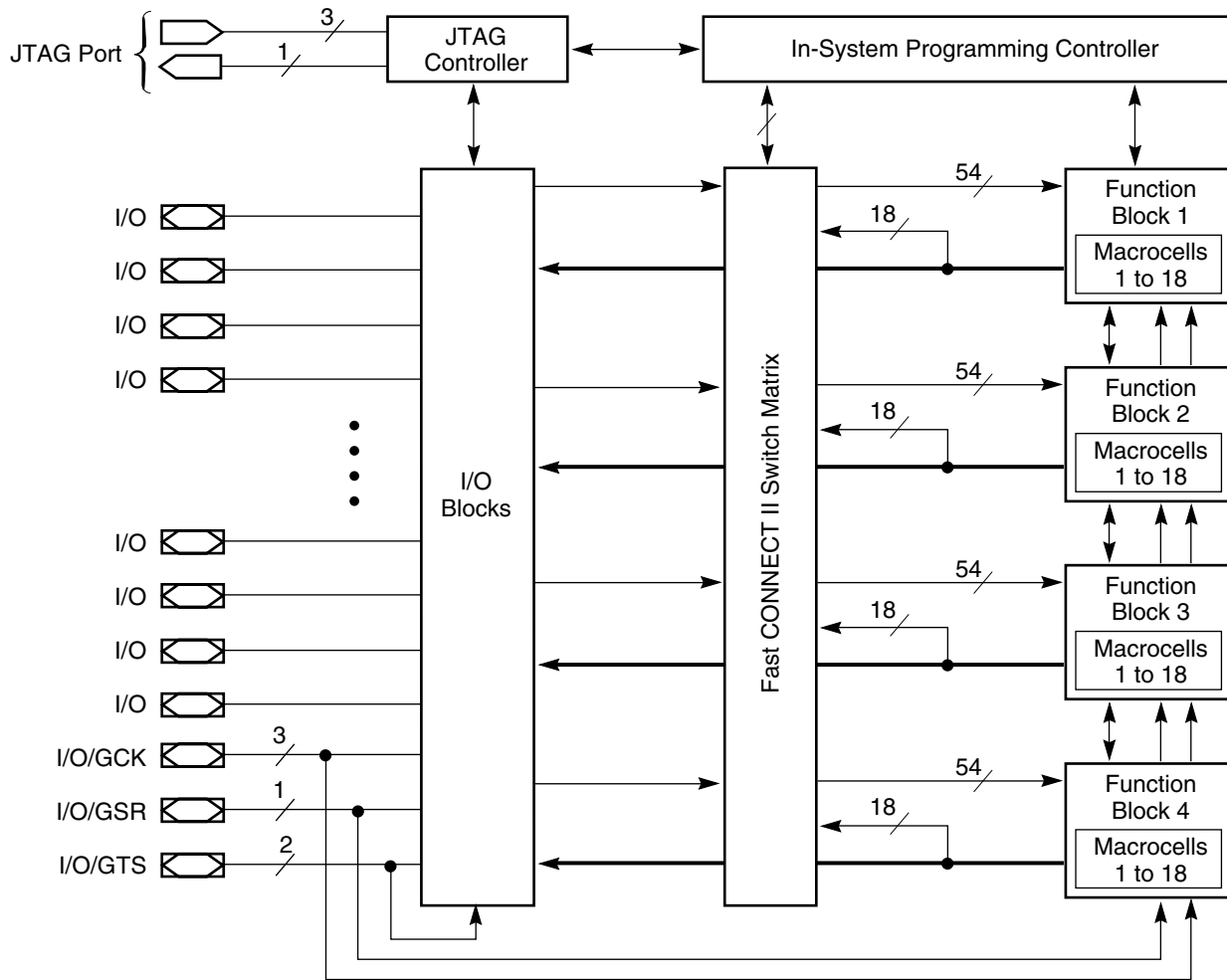

Figure 1: Typical  $I_{CC}$  vs. Frequency for XA9572XL



DS057\_02\_082800

**Figure 2: XA9572XL Architecture**  
 Function Block outputs (indicated by the bold line) drive the I/O Blocks directly.

## Absolute Maximum Ratings<sup>(1,3)</sup>

Symbol	Description	Value	Units
$V_{CC}$	Supply voltage relative to GND	-0.5 to 4.0	V
$V_{IN}$	Input voltage relative to GND <sup>(2)</sup>	-0.5 to 5.5	V
$V_{TS}$	Voltage applied to 3-state output <sup>(2)</sup>	-0.5 to 5.5	V
$T_{STG}$	Storage temperature (ambient) <sup>(4)</sup>	-65 to +150	°C
$T_J$	Junction temperature	+125	°C

**Notes:**

- All automotive customers are required to set the Macrocell Power Setting to low, and set Logic Optimization to density.
- Maximum DC undershoot below GND must be limited to either 0.5V or 10 mA, whichever is easier to achieve. During transitions, the device pins may undershoot to -2.0 V or overshoot to +7.0V, provided this over- or undershoot lasts less than 10 ns and with the forcing current being limited to 200 mA. External I/O voltage may not exceed  $V_{CCINT}$  by 4.0V.
- Stresses beyond those listed under Absolute Maximum Ratings may cause permanent damage to the device. These are stress ratings only, and functional operation of the device at these or any other conditions beyond those listed under Operating Conditions is not implied. Exposure to Absolute Maximum Ratings conditions for extended periods of time may affect device reliability.
- For soldering guidelines and thermal considerations, see the [Device Packaging](#) information on the Xilinx website. For Pb-free packages, see [XAPP427](#).

## Recommended Operation Conditions

Symbol	Parameter		Min	Max	Units
$T_A$	Ambient temperature	I-Grade	-40	+85	°C
		Q-Grade	-40	+105	°C
$V_{CCINT}$	Supply voltage for internal logic and input buffers		3.0	3.6	V
$V_{CCIO}$	Supply voltage for output drivers for 3.3V operation		3.0	3.6	V
	Supply voltage for output drivers for 2.5V operation		2.3	2.7	V
$V_{IL}$	Low-level input voltage		0	0.80	V
$V_{IH}$	High-level input voltage		2.0	5.5	V
$V_O$	Output voltage		0	$V_{CCIO}$	V

## Quality and Reliability Characteristics

Symbol	Parameter	Min	Max	Units
$T_{DR}$	Data Retention	20	-	Years
$N_{PE}$	Program/Erase Cycles (Endurance) @ $T_A = 70^\circ$	10,000	-	Cycles
$V_{ESD}$	Electrostatic Discharge (ESD)	2,000	-	Volts

## DC Characteristic Over Recommended Operating Conditions

Symbol	Parameter	Test Conditions	Min	Max	Units
$V_{OH}$	Output high voltage for 3.3V outputs	$I_{OH} = -4.0$ mA	2.4	-	V
	Output high voltage for 2.5V outputs	$I_{OH} = -500$ $\mu$ A	90% $V_{CCIO}$	-	V
$V_{OL}$	Output low voltage for 3.3V outputs	$I_{OL} = 8.0$ mA	-	0.4	V
	Output low voltage for 2.5V outputs	$I_{OL} = 500$ $\mu$ A	-	0.4	V
$I_{IL}$	Input leakage current	$V_{CC} = \text{Max}; V_{IN} = \text{GND or } V_{CC}$	-	$\pm 10$	$\mu$ A
$I_{IH}$	I/O high-Z leakage current	$V_{CC} = \text{Max}; V_{IN} = \text{GND or } V_{CC}$	-	$\pm 10$	$\mu$ A

Symbol	Parameter	Test Conditions	Min	Max	Units
$I_{IH}$	I/O high-Z leakage current	$V_{CC} = \text{Max}; V_{CCIO} = \text{Max}; V_{IN} = \text{GND or } 3.6\text{V}$	-	$\pm 10$	$\mu\text{A}$
		$V_{CC} \text{ Min} < V_{IN} < 5.5\text{V}$	-	$\pm 50$	$\mu\text{A}$
$C_{IN}$	I/O capacitance	$V_{IN} = \text{GND}; f = 1.0 \text{ MHz}$	-	10	pF
$I_{CC}$	Operating supply current (low power mode, active)	$V_{IN} = \text{GND}, \text{ No load}; f = 1.0 \text{ MHz}$	20 (Typical)		mA

### AC Characteristics

Symbol	Parameter	XA9572XL-15		Units
		Min	Max	
$T_{PD}$	I/O to output valid	-	15.5	ns
$T_{SU}$	I/O setup time before GCK	12.0	-	ns
$T_H$	I/O hold time after GCK	0	-	ns
$T_{CO}$	GCK to output valid	-	5.8	ns
$f_{SYSTEM}$	Multiple FB internal operating frequency	-	64.5	MHz
$T_{PSU}$	I/O setup time before p-term clock input	7.6	-	ns
$T_{PH}$	I/O hold time after p-term clock input	0.0	-	ns
$T_{PCO}$	P-term clock output valid	-	10.2	ns
$T_{OE}$	GTS to output valid	-	7.0	ns
$T_{OD}$	GTS to output disable	-	7.0	ns
$T_{POE}$	Product term OE to output enabled	-	11.0	ns
$T_{POD}$	Product term OE to output disabled	-	11.0	ns
$T_{AO}$	GSR to output valid	-	14.5	ns
$T_{PAO}$	P-term S/R to output valid	-	15.3	ns
$T_{WLH}$	GCK pulse width (High or Low)	4.5	-	ns
$T_{APRPW}$	Asynchronous preset/reset pulse width (High or Low)	7.0	-	ns
$T_{PLH}$	P-term clock pulse width (High or Low)	7.0	-	ns
$T_{SUEC}$	Clock enable setup	6.5	-	ns
$T_{HEC}$	Clock enable hold	0	-	ns

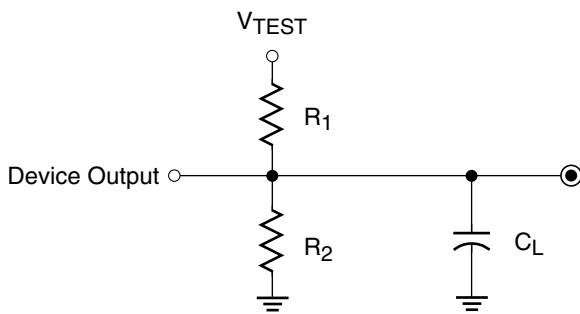

Output Type	$V_{CCIO}$	$V_{TEST}$	$R_1$	$R_2$	$C_L$
	3.3V	3.3V	320 $\Omega$	360 $\Omega$	35 pF
	2.5V	2.5V	250 $\Omega$	660 $\Omega$	35 pF

DS058\_03\_081500

Figure 3: AC Load Circuit

## Internal Timing Parameters

Symbol	Parameter	XA9572XL-15		Units
		Min	Max	
<b>Buffer Delays</b>				
$T_{IN}$	Input buffer delay	-	3.5	ns
$T_{GCK}$	GCK buffer delay	-	1.8	ns
$T_{GSR}$	GSR buffer delay	-	4.5	ns
$T_{GTS}$	GTS buffer delay	-	7.0	ns
$T_{OUT}$	Output buffer delay	-	3.0	ns
$T_{EN}$	Output buffer enable/disable delay	-	0	ns
<b>Product Term Control Delays</b>				
$T_{PTCK}$	Product term clock delay	-	2.7	ns
$T_{PTSR}$	Product term set/reset delay	-	1.8	ns
$T_{PTTS}$	Product term 3-state delay	-	7.5	ns
<b>Internal Register and Combinatorial Delays</b>				
$T_{PDI}$	Combinatorial logic propagation delay	-	1.7	ns
$T_{SUI}$	Register setup time	3.0	-	ns
$T_{HI}$	Register hold time	3.5	-	ns
$T_{ECSU}$	Register clock enable setup time	3.0	-	ns
$T_{ECHO}$	Register clock enable hold time	3.5	-	ns
$T_{COI}$	Register clock to output valid time	-	1.0	ns
$T_{AOI}$	Register async. S/R to output delay	-	7.0	ns
$T_{RAI}$	Register async. S/R recover before clock	10.0	-	ns
$T_{LOGI}$	Internal logic delay	-	7.3	ns
<b>Feedback Delays</b>				
$T_F$	Fast CONNECT II feedback delay	-	4.2	ns
<b>Time Adders</b>				
$T_{PTA}$	Incremental product term allocator delay	-	1.0	ns
$T_{SLEW}$	Slew-rate limited delay	-	4.5	ns

## XA9572XL I/O Pins

Function Block	Macrocell	VQG44	VQG64	TQG100	BScan Order
1	1	-	-	16	213
1	2	39	8	13	210
1	3	-	12	18	207
1	4	-	13	20	204
1	5	40	9	14	201
1	6	41	10	15	198
1	7	-	-	25	195
1	8	42	11	17	192
1	9	43 <sup>(1)</sup>	15 <sup>(1)</sup>	22 <sup>(1)</sup>	189
1	10	-	18	28	186
1	11	44 <sup>(1)</sup>	16 <sup>(1)</sup>	23 <sup>(1)</sup>	183
1	12	-	23	33	180
1	13	-	-	36	177
1	14	1 <sup>(1)</sup>	17 <sup>(1)</sup>	27 <sup>(1)</sup>	174
1	15	2	19	29	171
1	16	-	-	39	168
1	17	3	20	30	165
1	18	-	-	40	162
2	1	-	-	87	159
2	2	29	60	94	156
2	3	-	58	91	153
2	4	-	59	93	150
2	5	30	61	95	147
2	6	31	62	96	144
2	7	-	-	3 <sup>(2)</sup>	141
2	8	32	63	97	138
2	9	33 <sup>(1)</sup>	64 <sup>(1)</sup>	99 <sup>(1)</sup>	135
2	10	-	1	1	132
2	11	34 <sup>(1)</sup>	2 <sup>(1)</sup>	4 <sup>(1)</sup>	129
2	12	-	4	6	126
2	13	-	-	8	123
2	14	36 <sup>(2)</sup>	5 <sup>(2)</sup>	9	120
2	15	37	6	11	117
2	16	-	-	10	114
2	17	38	7	12	111
2	18	-	-	92	108

Function Block	Macrocell	VQG44	VQG64	TQG100	BScan Order
3	1	-	-	41	105
3	2	5	22	32	102
3	3	-	31	49	99
3	4	-	32	50	96
3	5	6	24	35	93
3	6	-	34	53	90
3	7	-	-	54	87
3	8	7	25	37	84
3	9	8	27	42	81
3	10	-	39	60	78
3	11	12	33	52	75
3	12	-	40	61	72
3	13	-	-	63	69
3	14	13	35	55	66
3	15	14	36	56	63
3	16	18	42	64	60
3	17	16	38	58	57
3	18	-	-	59	54
4	1	-	-	65	51
4	2	19	43	67	48
4	3	-	46	71	45
4	4	-	47	72	42
4	5	20	44	68	39
4	6	-	49	76	36
4	7	-	-	77	33
4	8	21	45	70	30
4	9	-	-	66	27
4	10	-	51	81	24
4	11	22	48	74	21
4	12	-	52	82	18
4	13	-	-	85	15
4	14	23	50	78	12
4	15	27	56	89	9
4	16	-	-	86	6
4	17	28	57	90	3
4	18	-	-	79	0

### Notes:

1. Global control pin.
2. GTS1

## XA9572XL Global, JTAG and Power Pins

Pin Type	VQG44	VQG64	TQG100
I/O/GCK1	43	15	22
I/O/GCK2	44	16	23
I/O/GCK3	1	17	27
I/O/GTS1	36	5	3
I/O/GTS2	34	2	4
I/O/GSR	33	64	99
TCK	11	30	48
TDI	9	28	45
TDO	24	53	83
TMS	10	29	47
V <sub>CCINT</sub> 3.3V	15, 35	3, 37	5, 57, 98
V <sub>CCIO</sub> 2.5V/3.3V	26	26, 55	26, 38, 51, 88
GND	4, 17, 25	14, 21, 41, 54	21, 31, 44, 62, 69, 75, 84, 100
No Connects	-	-	2, 7, 19, 24, 34, 43, 46, 73, 80

## Device Part Marking and Ordering Combination Information

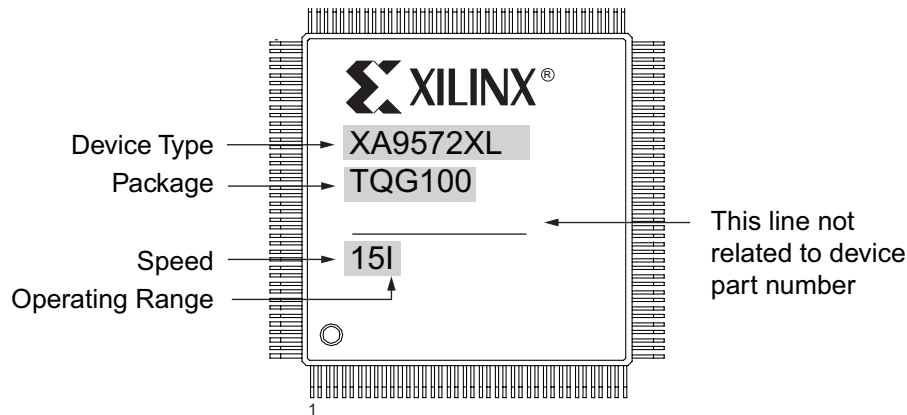

Sample package with part marking.

Device Ordering and Part Marking Number	Speed (pin-to-pin delay)	Pkg. Symbol	No. of Pins	Package Type	Operating Range <sup>(1)</sup>
XA9572XL-15VQG44I	15.5 ns	VQG44	44-pin	Quad Flat Pack (VQFP)	I
XA9572XL-15VQG64I	15.5 ns	VQG64	64-pin	Quad Flat Pack (VQFP)	I
XA9572XL-15TQG100I	15.5 ns	TQG100	100-pin	Thin Quad Flat Pack (TQFP)	I
XA9572XL-15VQG44Q	15.5 ns	VQG44	44-pin	Quad Flat Pack (VQFP)	Q
XA9572XL-15VQG64Q	15.5 ns	VQG64	64-pin	Quad Flat Pack (VQFP)	Q
XA9572XL-15TQG100Q	15.5 ns	TQG100	100-pin	Thin Quad Flat Pack (TQFP)	Q

### Notes:

I-Grade:  $T_A = -40^\circ$  to  $+85^\circ\text{C}$ ; Q-Grade:  $T_A = -40^\circ$  to  $+105^\circ\text{C}$ .



## XA9500XL Automotive Requirements and Recommendations

### Requirements

The following requirements are for all automotive applications:

- All automotive customers are required to keep the Macrocell Power selection set to low, and the Logic Optimization set to density when designing with ISE software. These are the default settings when XA9500XL devices are selected for design. These settings are found on the Process Properties page for Implement Design. See the ISE Online Help for details on these properties.
- Use a monotonic, fast ramp power supply to power up XA9500XL. A  $V_{CC}$  ramp time of less than 1 ms is required.
- Do not float I/O pins during device operation. Floating I/O pins can increase  $I_{CC}$  as input buffers will draw 1-2 mA per floating input. In addition, when I/O pins are floated, noise can propagate to the center of the CPLD. I/O pins should be appropriately terminated with keeper/bus-hold. Unused I/Os can also be configured as  $C_{GND}$  (programmable GND).
- Do not drive I/O pins without  $V_{CC}/V_{CCIO}$  powered.
- Sink current when driving LEDs. Because all Xilinx CPLDs have N-channel pull-down transistors on outputs, it is required that an LED anode is sourced through a resistor externally to  $V_{CC}$ . Consequently, this will give the brightest solution.
- Avoid external pull-down resistors. Always use external pull-up resistors if external termination is required. This is because the XC9500XL Automotive CPLD, which



includes some I/O driving circuits beyond the input and output buffers, may have contention with external pull-down resistors, and, consequently, the I/O will not switch as expected.

7. Do not drive I/Os pins above the  $V_{CCIO}$  assigned to its I/O bank.
    - a. The current flow can go into  $V_{CCIO}$  and affect a user voltage regulator.
    - b. It can also increase undesired leakage current associated with the device.
    - c. If done for too long, it can reduce the life of the device.
  8. Do not rely on the I/O states before the CPLD configures.
  9. Use a voltage regulator which can provide sufficient current during device power up. As a rule of thumb, the regulator needs to provide at least three times the peak current while powering up a CPLD in order to guarantee the CPLD can configure successfully.
  10. Ensure external JTAG terminations for TMS, TCK, TDI, TDO comply with IEEE 1149.1. All Xilinx CPLDs have internal weak pull-ups of  $\sim 50\text{ k}\Omega$  on TDI, TMS, and TCK.
  11. Attach all CPLD  $V_{CC}$  and GND pins in order to have necessary power and ground supplies around the CPLD.
  12. Decouple all  $V_{CC}$  and  $V_{CCIO}$  pins with capacitors of  $0.01\ \mu\text{F}$  and  $0.1\ \mu\text{F}$  closest to the pins for each  $V_{CC}/V_{CCIO}$ -GND pair.
2. Include JTAG stakes on the PCB. JTAG stakes can be used to test the part on the PCB. They add benefit in reprogramming part on the PCB, inspecting chip internals with INTEST, identifying stuck pins, and inspecting programming patterns (if not secured).
  3. XA9500XL Automotive CPLDs work with any power sequence, but it is preferable to power the  $V_{CCI}$  (internal  $V_{CC}$ ) before the  $V_{CCIO}$  for the applications in which any glitches from device I/Os are unwanted.
  4. Do not disregard report file warnings. Software identifies potential problems when compiling, so the report file is worth inspecting to see exactly how your design is mapped onto the logic.
  5. Understand the Timing Report. This report file provides a speed summary along with warnings. Read the timing file (\*.tim) carefully. Analyze key signal chains to determine limits to given clock(s) based on logic analysis.
  6. Review Fitter Report equations. Equations can be shown in ABEL-like format, or can also be displayed in Verilog or VHDL formats. The Fitter Report also includes switch settings that are very informative of other device behaviors.
  7. Let design software define pinouts if possible. Xilinx CPLD software works best when it selects the I/O pins and manages resources for users. It can spread signals around and improve pin-locking. If users must define pins, plan resources in advance.
  8. Perform a post-fit simulation for all speeds to identify any possible problems (such as race conditions) that might occur when fast-speed silicon is used instead of slow-speed silicon.
  9. Distribute SSOs (Simultaneously Switching Outputs) evenly around the CPLD to reduce switching noise.
  10. Terminate high speed outputs to eliminate noise caused by very fast rising/falling edges.

## Recommendations

The following recommendations are for all automotive applications.

1. Use strict synchronous design (only one clocking event) if possible. A synchronous system is more robust than an asynchronous one.

---



---

## Warranty Disclaimer

THIS WARRANTY DOES NOT EXTEND TO ANY IMPLEMENTATION IN AN APPLICATION OR ENVIRONMENT THAT IS NOT CONTAINED WITHIN XILINX SPECIFICATIONS. PRODUCTS ARE NOT DESIGNED TO BE FAIL-SAFE AND ARE NOT WARRANTED FOR USE IN THE DEPLOYMENT OF AIRBAGS. FURTHER, PRODUCTS ARE NOT WARRANTED FOR USE IN APPLICATIONS THAT AFFECT CONTROL OF THE VEHICLE UNLESS THERE IS A FAIL-SAFE OR REDUNDANCY FEATURE AND ALSO A WARNING SIGNAL TO THE OPERATOR OF THE VEHICLE UPON FAILURE. USE OF PRODUCTS IN SUCH APPLICATIONS IS FULLY AT THE RISK OF CUSTOMER SUBJECT TO APPLICABLE LAWS AND REGULATIONS GOVERNING LIMITATIONS ON PRODUCT LIABILITY.

## Further Reading

The following Xilinx links go to relevant XC9500XL CPLD documentation, including XAPP111, Using the XC9500XL Timing Model, and XAPP784, Bulletproof CPLD Design Practices. Simply click on the link and scroll down.

[Data Sheets, Application Notes, and White Papers.](#)

[Packaging](#)

## Revision History

The following table shows the revision history for this document.

Date	Version	Revision
01/12/07	1.0	Initial Xilinx release.
04/03/07	1.1	Add programming temperature range warning on page 1.