

FEMALE END VIEW

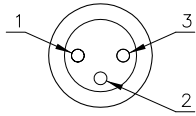

- 1 = BROWN
- 2 = BLACK
- 3 = BLUE



SPECIFICATIONS

CONTACT CARRIER MATERIAL	PA 6-GV (NYLON)
MOLDED HEAD MATERIAL/COLOR	TPU/BLACK
CONTACT MATERIAL/PLATING	GOLD-PLATED BRASS
COUPLING NUT MATERIAL/PLATING	AISI TYPE 303 STAINLESS STEEL/PASSIVATED PER QQ-P-35, TYPE IV, METHOD 1
RATED CURRENT [A]	4.0 A
RATED VOLTAGE [V]	125 VAC/VDC
OUTER JACKET MATERIAL/COLOR	TPU/BLACK
CONDUCTOR INSULATION MATERIAL	PVC
NUMBER OF CONDUCTORS [AWG]	3x24 AWG
DRAIN/SHIELD	26 AWG DRAIN/FOIL SHIELD
TEMPERATURE RANGE	-40°C to +80°C (-40°F to +176°F)
PROTECTION CLASS	MEETS NEMA 1,3,4,6,13 AND IEC IP67

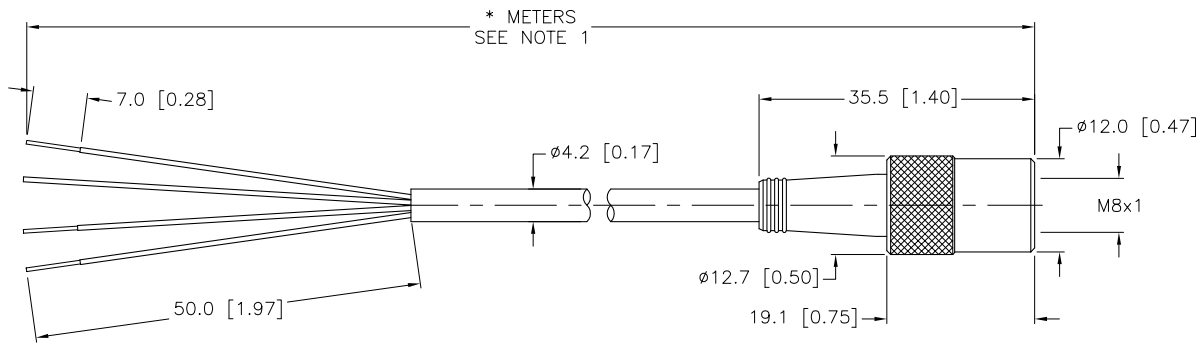

CABLE LENGTH	TOLERANCE
ALL LENGTHS	+ 4% (OR 50mm) OF LENGTH - 0% (OR 0mm) OF LENGTH WHICHEVER IS GREATER
STRIP LENGTH	TOLERANCE
0-7mm	±0.5mm
8-29mm	±1.0mm
30-49mm	±2.0mm
50-69mm	±3.0mm
70-100mm	±4.0mm
OVER 100mm	±5.0mm

SOURCE DRAWING - FOR REFERENCE ONLY

NOTES:

- "*" INDICATES CABLE LENGTH IN METERS. CONTACT TURCK TO ORDER SPECIFIC LENGTHS.
- "/S771" INDICATES MOLDED BLACK PLUG BODY.
- "/S1517" INDICATES THERMOPLASTIC POLYURETHANE (TPU) SHIELDED CABLE AND CUSTOM EXTENDED COUPLING NUT.

RELATED DOCUMENTS	3RD ANGLE PROJECTION	THIS DRAWING IS CONFIDENTIAL AND THE PROPERTY OF TURCK INC. USE OF THIS DOCUMENT WITHOUT WRITTEN PERMISSION IS PROHIBITED.	<p>3000 CAMPUS DRIVE MINNEAPOLIS, MN 55441 1-800-544-7769 (763) 553-7300 (763) 553-0708 fax turck.com</p>	
1.		DRFT	DATE 10/18/02	DESCRIPTION PKG V 3M-*/S771/S1517
2.		APVD	SCALE 1=1.0	
3.	ALL DIMENSIONS DISPLAYED ON THIS DRAWING ARE FOR REFERENCE ONLY	UNIT OF MEASUREMENT MILLIMETER [INCH]		IDENTIFICATION NO.
4.		CONTACT TURCK FOR MORE INFORMATION		REV D
MATERIAL	SEE SPECIFICATIONS	DO NOT SCALE THIS DRAWING		FILE: 777001322
FINISH	SEE SPECIFICATIONS	SHEET 1 OF 1		

D	UPDATE CABLE DIAMETER	KMY	11/03/11	36133
REV	DESCRIPTION	BY	DATE	ECO NO.