

DESCRIPTION

The IF-E91D is a high-optical-output, high-speed, infrared LED housed in a “connector-less” style plastic fiber optic package. High performance at economical cost is provided by the IF-E91D in a variety of applications. The device package features an internal micro-lens and a precision-molded PBT housing to ensure efficient optical coupling with standard 1000 μm core plastic fiber cable.

APPLICATION HIGHLIGHTS

The high output and fast transition times of the IF-E91D make it suitable for low-cost digital data links. Using standard 1000 μm core plastic fiber, the IF-E91D LED is ideally suited for distances up to 10 meters at data rates of 100 Mbps. The drive circuit design is simpler than required for laser diodes, making the IF-E91D a good low-cost device in a variety of short distance analog and digital applications.

APPLICATIONS

- Low-Cost Digital Data Links
- Optical Sensors
- Audio Systems
- Medical Instruments
- Automotive Electronics
- Robotics Communications
- Local Area Networks (LANs)
- Wavelength Multiplexing
- Electronic Games

FEATURES

- ◆ High Infrared Optical Power
- ◆ Fast Rise and Fall Times
- ◆ Economically Priced
- ◆ Mates with Standard 1000 μm Core Jacketed Plastic Fiber Cable
- ◆ Internal Micro-Lens for Maximum Coupling
- ◆ Inexpensive Plastic Connector Housing
- ◆ Connector-Less Fiber Termination
- ◆ Light-Tight Housing Provides Interference-Free Transmission
- ◆ RoHS Compliant

MAXIMUM RATINGS

($T_A = 25^\circ\text{C}$)

Operating and Storage Temperature Range (T_{OP}, T_{STG})..... -40° to 85°C
 Junction Temperature (T_J)..... 85°C
 Soldering Temperature (2mm from case bottom) (T_S) $t \leq 5$ s..... 240°C
 Reverse Voltage (V_R).....3 V
 Power Dissipation (P_{TOT}) $T_A = 25^\circ\text{C}$60 mW
 De-rate Above 25°C1.33 mW/ $^\circ\text{C}$
 Forward Current, DC (I_F).....60 mA
 Surge Current (I_{FSM}) $t \leq 10 \mu\text{sec}$ duty cycle $< 5\%$1 A

CHARACTERISTICS ($T_A = 25^\circ\text{C}$)

Parameter	Symbol	Min.	Typ.	Max.	Unit
Peak Wavelength	λ_{PEAK}	860	870	875	nm
Spectral Bandwidth (50% of I_{MAX})	$\Delta\lambda$	–	50	–	nm
Output Power Coupled into Plastic Fiber (1 mm core diameter). Distance Lens to Fiber ≤ 0.1 mm, 1m SH4001 polished fiber, $I_F = 20$ mA	Φ_{min}	110 -9.6	150 -8.2	180 -7.4	μW dBm
Switching Times (10% to 90% and 90% to 10%) (Figure 3)	t_r, t_f	–	3.0	–	ns
Capacitance ($I_F = 1$ MHz)	C_0	–	60	–	pF
Forward Voltage ($I_F = 20$ mA)	V_f	–	1.38	1.58	V
Temperature Coefficient, λ_{PEAK}	TC_λ	–	0.3	–	nm/K

CAUTION: The IF E91D is ESD sensitive. To minimize risk of damage observe appropriate precautions during handling and processing.

IF E91D 100 Mbps Plastic Fiber Optic IR LED

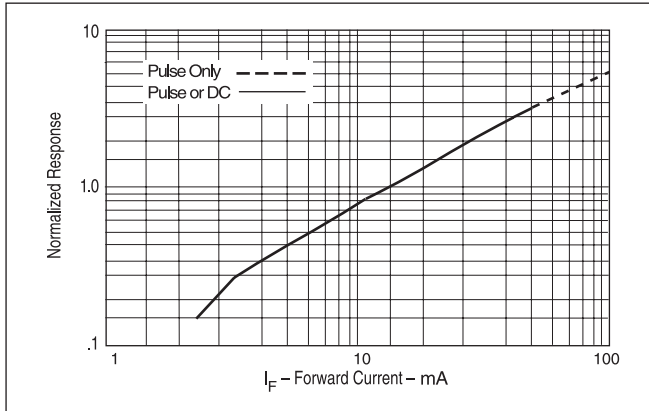

FIGURE 1. Normalized power launched versus forward current.

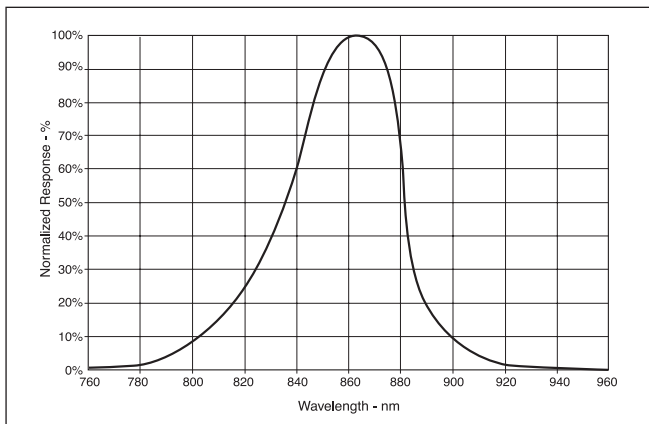

FIGURE 2. Typical spectral output vs. wavelength.

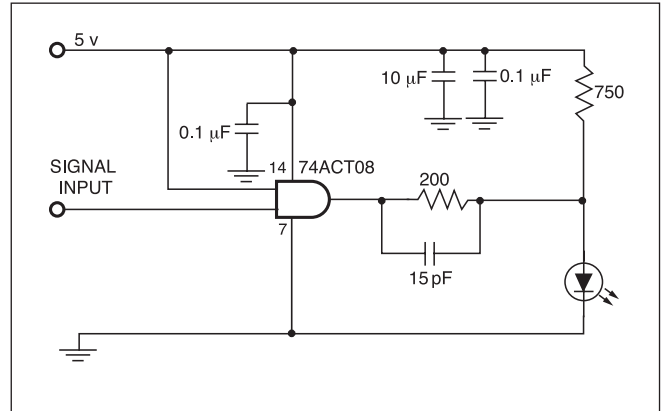

FIGURE 3. Test drive circuit (IF = 22mA).

FIBER TERMINATION INSTRUCTIONS

1. Cut off the ends of the optical fiber with a single-edge razor blade or sharp knife. Try to obtain a precise 90-degree angle (square).
2. Insert the fiber through the locking nut and into the connector until the core tip seats against the internal micro-lens.
3. Screw the connector locking nut down to a snug fit, locking the fiber in place.

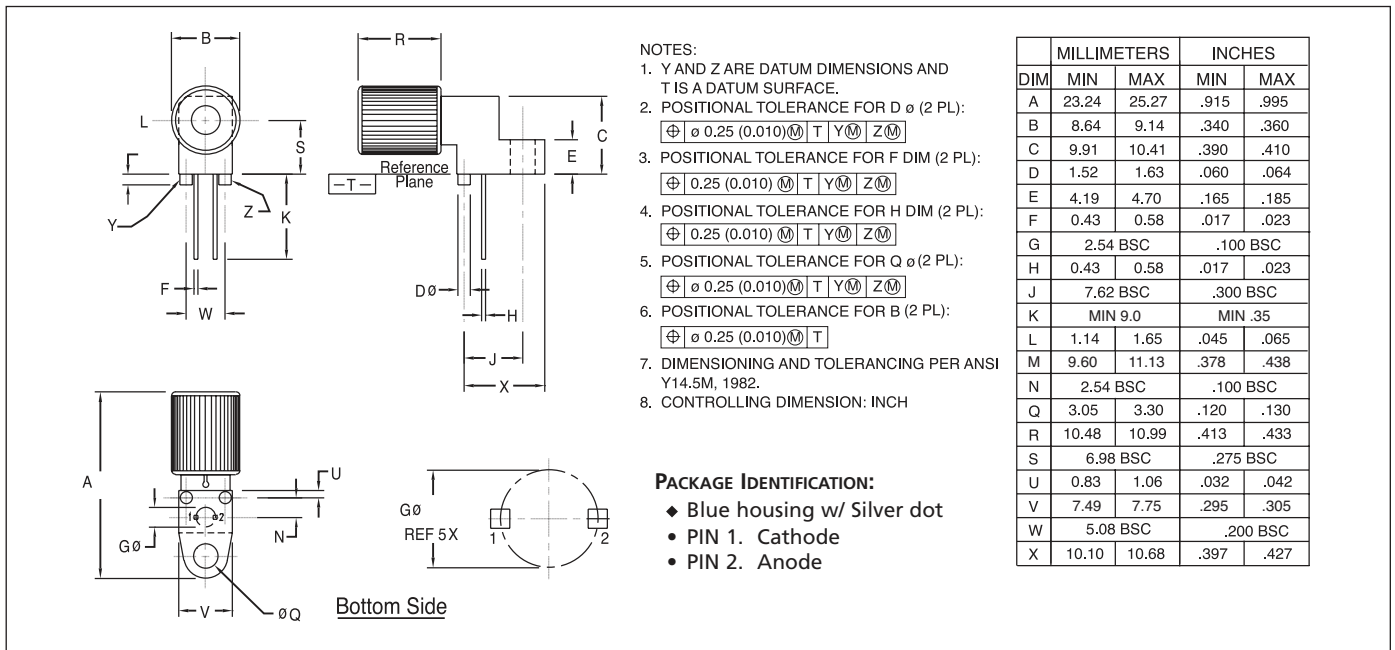

FIGURE 4. Case outline. Specifications are believed to be accurate but are subject to change. Industrial Fiber Optics assumes no responsibility for the consequences of using the information provided beyond replacement warranty for products not meeting stated specifications. Industrial Fiber Optics products are not authorized for use in life support applications without written approval from the President of Industrial Fiber Optics Corporation.

CAUTION:

- To avoid degraded device life due to package stress, do not bend or form leads outside the orientation shown on drawing.
- Ensure that solder flux does not migrate into the device and block the optical path, degrading the performance.
- If washing the device, liquid may become trapped in the part cavity. Ensure that all potentially corrosive materials are flushed out of the device.