



## TURBOSWITCH™ ULTRA-FAST HIGH VOLTAGE DIODE

### MAIN PRODUCT CHARACTERISTICS

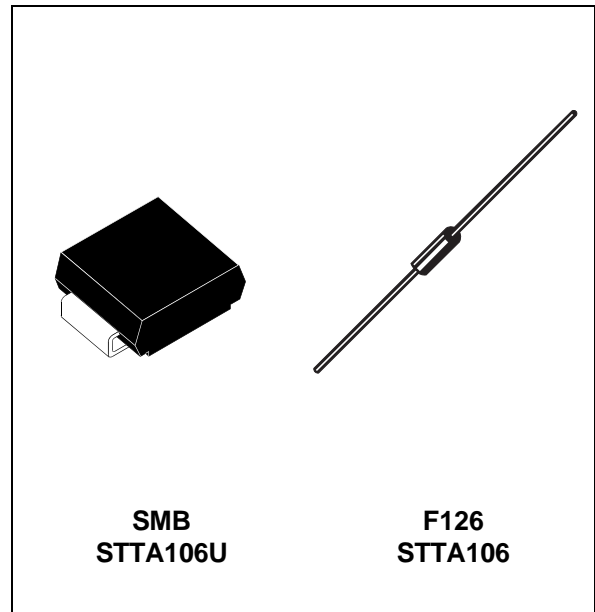
$I_{F(AV)}$	1A
$V_{RRM}$	600V
$t_{rr}$ (typ)	20ns
$V_F$ (max)	1.5V

### FEATURES AND BENEFITS

- SPECIFIC TO FREEWHEEL MODE OPERATIONS : FREEWHEEL OR BOOSTER DIODE
- ULTRA-FAST AND SOFT RECOVERY
- VERY LOW OVERALL POWER LOSSES IN BOTH THE DIODE AND THE COMPANION TRANSISTOR
- HIGH FREQUENCY OPERATIONS

### DESCRIPTION

The TURBOSWITCH is a very high performance series of ultra-fast high voltage power diodes. TURBOSWITCH family drastically cuts losses in both the diode and the associated switching IGBT and MOSFET in all freewheel mode operations and is particularly suitable and efficient in motor



control freewheel applications and in booster diode applications in power factor control circuitries.

Available either in SMB or F126 axial package, these 600V devices are particularly intended for use on 240V domestic mains.

### ABSOLUTE RATINGS (limiting values)

Symbol	Parameter	Value	Unit
$V_{RRM}$	Repetitive peak reverse voltage	600	V
$I_{F(RMS)}$	RMS forward current	6	A
$I_{FRM}$	Repetitive peak forward current	$t_p = 5 \mu s$ $F = 5kHz$ square	10 A
$I_{FSM}$	Surge non repetitive forward current	$t_p = 10 ms$ sinusoidal	25 A
$T_j$	Maximum operating junction temperature	125	°C
$T_{stg}$	Storage temperature range	- 65 to + 150	°C

TM : TURBOSWITCH is a trademark of STMicroelectronics

## STTA106/U

### THERMAL AND POWER DATA

Symbol	Parameter	Test conditions	Value	Unit	
$R_{th(j-l)}$	Junction to lead	SMB	23	°C/W	
	Junction to lead L=5mm	F126	45	°C/W	
$P_1$	Conduction power dissipation	$I_{F(AV)} = 0.8A$ $\delta = 0.5$ Tlead= 93°C	SMB	1.4	W
		$I_{F(AV)} = 0.8A$ $\delta = 0.5$ Tlead= 60°C	F126	1.4	W
$P_{max}$	Total power dissipation $P_{max} = P_1 + P_3$ ( $P_3 = 10\% P_1$ )	Tlead= 90°C	SMB	1.5	W
		Tlead= 60°C	F126	1.5	W

### STATIC ELECTRICAL CHARACTERISTICS

Symbol	Parameter	Test conditions	Min	Typ	Max	Unit
$V_F^*$	Forward voltage drop	$I_F = 1A$ Tj = 25°C Tj = 125°C		1.1	1.75 1.5	V
$I_R^{**}$	Reverse leakage current	$V_R = 0.8 \times V_{RRM}$ Tj = 25°C Tj = 125°C		250	10 750	μA
$V_{to}$	Threshold voltage	$I_p < 3 \cdot I_{F(AV)}$ Tj = 125°C			1.15	V
$R_d$	Dynamic resistance				350	mΩ

Test pulse : \*  $t_p = 380 \mu s$ ,  $\delta < 2\%$   
 \*\*  $t_p = 5 ms$ ,  $\delta < 2\%$

To evaluate the maximum conduction losses use the following equation :

$$P = V_{to} \times I_{F(AV)} + R_d \times I_{F(RMS)}^2$$

### DYNAMIC ELECTRICAL CHARACTERISTICS

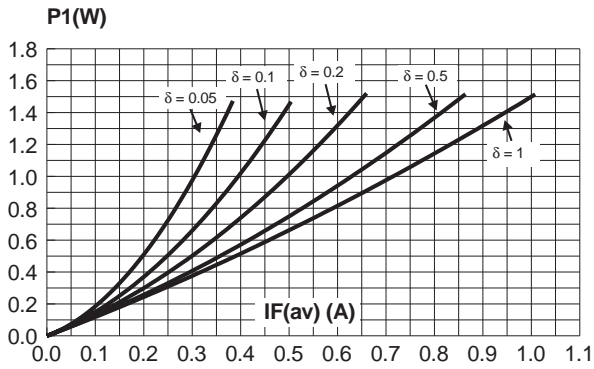
#### TURN-OFF SWITCHING

Symbol	Parameter	Test conditions	Min	Typ	Max	Unit
$t_{rr}$	Reverse recovery time	Tj = 25°C $I_F = 0.5 A$ $I_R = 1A$ $I_{rr} = 0.25A$ $I_F = 1 A$ $di_F/dt = -50A/\mu s$ $V_R = 30V$		20	50	ns
$I_{RM}$	Maximum recovery current	Tj = 125°C $V_R = 400V$ $I_F = 1A$ $di_F/dt = -8 A/\mu s$ $di_F/dt = -50 A/\mu s$		1.6	0.6	A
S factor	Softness factor	Tj = 125°C $V_R = 400V$ $I_F = 1A$ $di_F/dt = -50 A/\mu s$		1.1		/

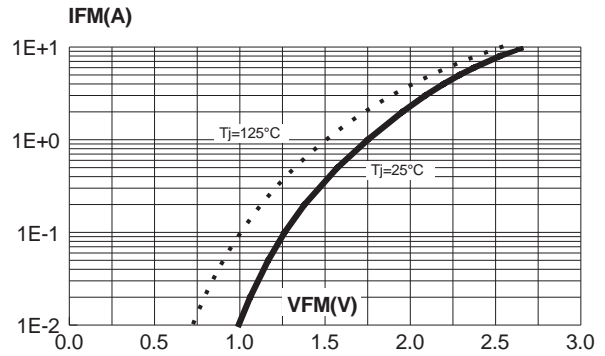
#### TURN-ON SWITCHING

Symbol	Parameter	Test conditions	Min	Typ	Max	Unit
$t_{fr}$	Forward recovery time	Tj = 25°C $I_F = 1 A$ , $di_F/dt = 8 A/\mu s$			500	ns
$V_{Fp}$	Peak forward voltage	measured at $1.1 \times V_F$ max			10	V

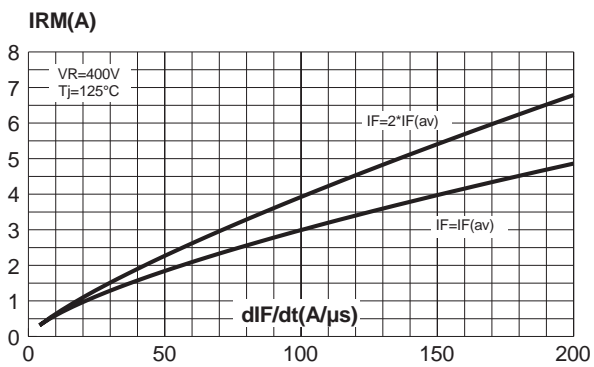
**Fig. 1:** Conduction losses versus average current.



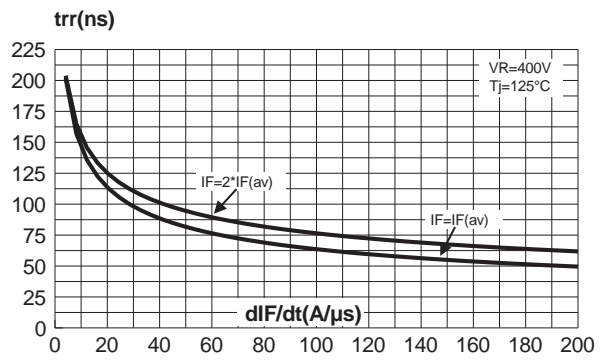
**Fig. 2:** Forward voltage drop versus forward current (maximum values).



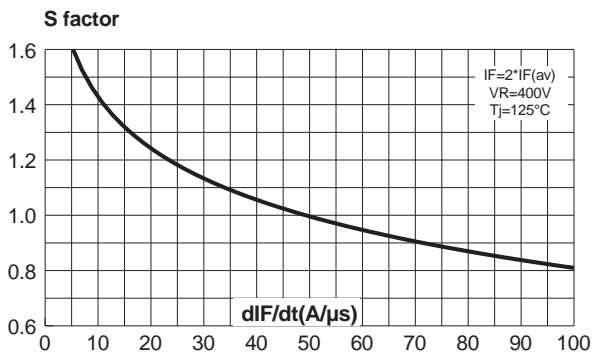
**Fig. 3:** Peak reverse recovery current versus  $dI_F/dt$  (90% confidence).



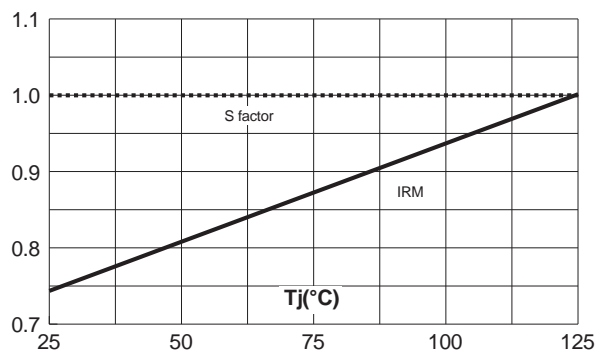
**Fig. 4:** Reverse recovery time versus  $dI_F/dt$  (90% confidence).



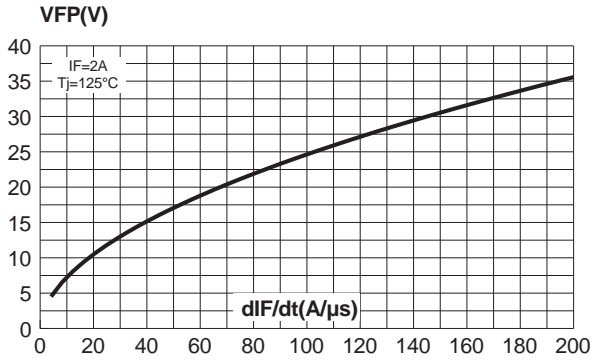
**Fig. 5:** Softness factor (tb/ta) versus  $dI_F/dt$  (typical values).



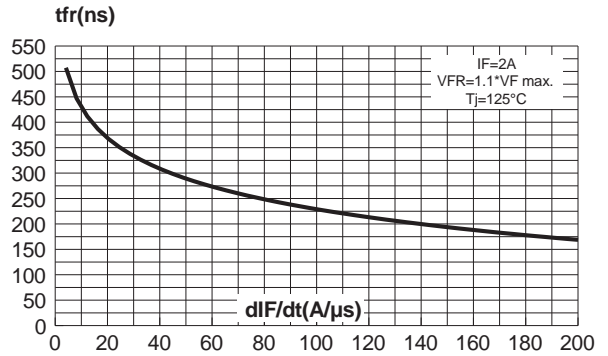
**Fig. 6:** Relative variation of dynamic parameters versus junction temperature (reference  $T_j = 125^\circ\text{C}$ ).



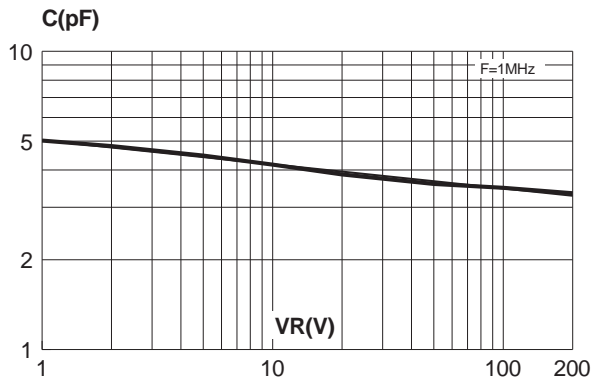
**Fig. 7:** Transient peak forward voltage versus  $dI_F/dt$  (90% confidence).



**Fig. 8:** Forward recovery time versus  $dI_F/dt$  (90% confidence).



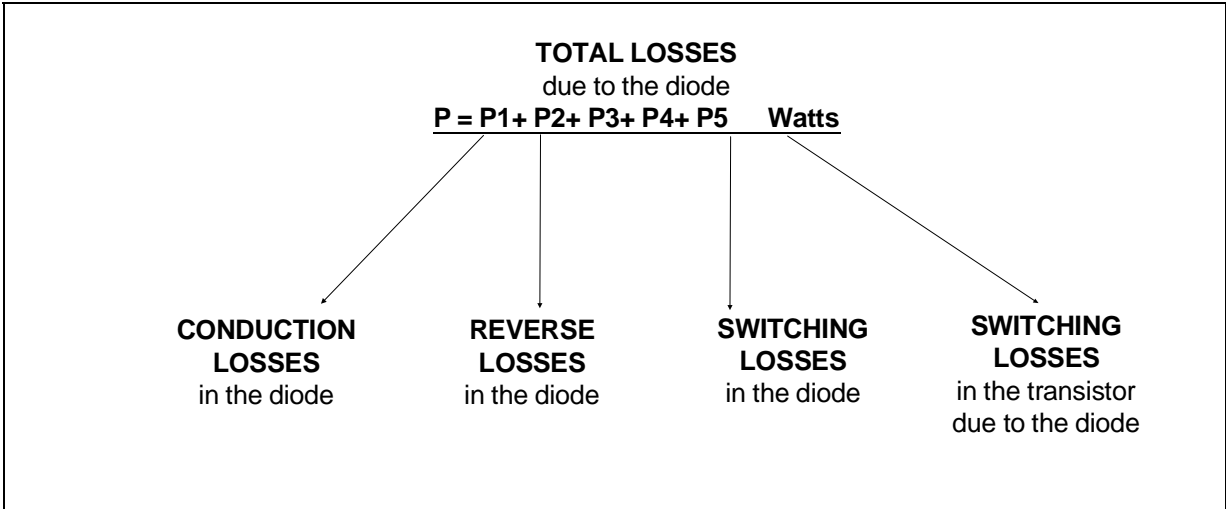
**Fig. 9:** Junction capacitance versus reverse voltage applied (typical values).



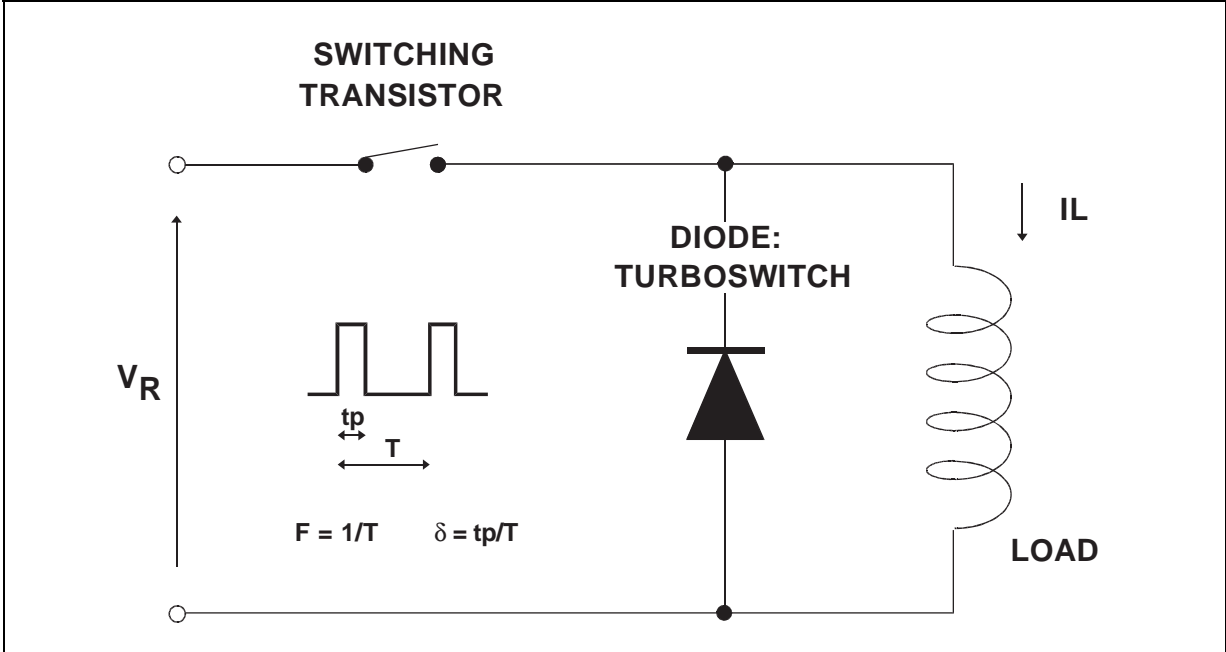
**APPLICATION DATA**

The TURBOSWITCH™ is especially designed to provide the lowest overall power losses in any "Freewheel Mode" application (see fig. A) considering both diode and companion transistor, thus optimizing the overall performance in the end application.

The way of calculating the power losses is given below :

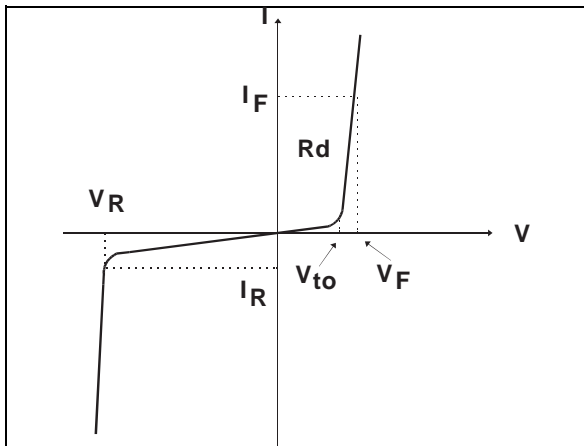


**Fig. A : "FREEWHEEL" MODE**



APPLICATION DATA (Cont'd)

Fig. B : STATIC CHARACTERISTICS



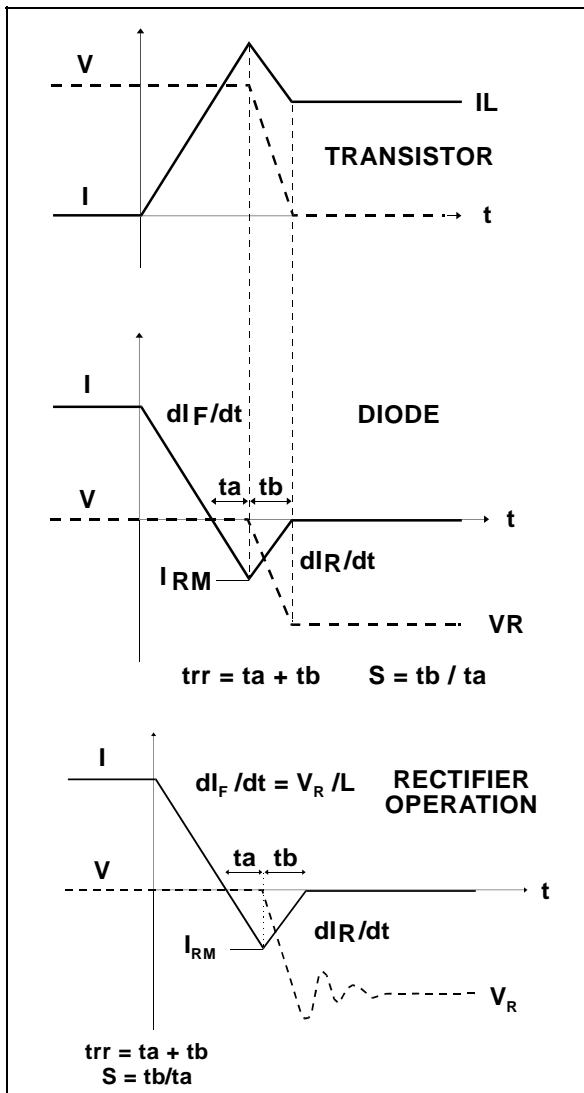
**Conduction losses :**

$$P1 = V_{to} \times I_{F(AV)} + R_d \times I_F^2(RMS)$$

**Reverse losses :**

$$P2 = V_R \times I_R \times (1 - \delta)$$

Fig. C : TURN-OFF CHARACTERISTICS



**Turn-on losses :**

(in the transistor, due to the diode)

$$P5 = \frac{V_R \times I_{RM}^2 \times (3+2 \times S) \times F}{6 \times dI_F/dt} + \frac{V_R \times I_{RM} \times I_L \times (S+2) \times F}{2 \times dI_F/dt}$$

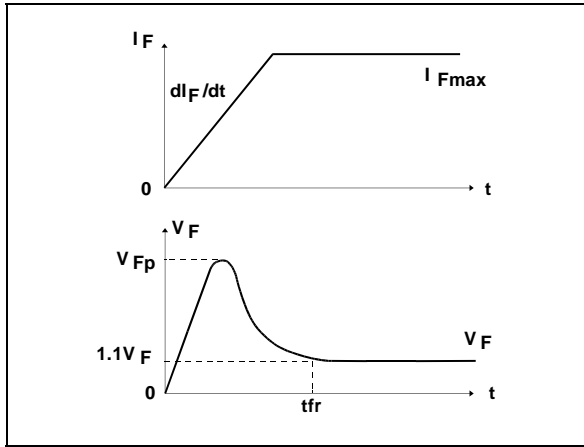
**Turn-off losses (in the diode) :**

$$P3 = \frac{V_R \times I_{RM}^2 \times S \times F}{6 \times dI_F/dt}$$

P3 and P5 are suitable for power MOSFET and IGBT

APPLICATION DATA (Cont'd)

Fig. D : TURN-ON CHARACTERISTICS

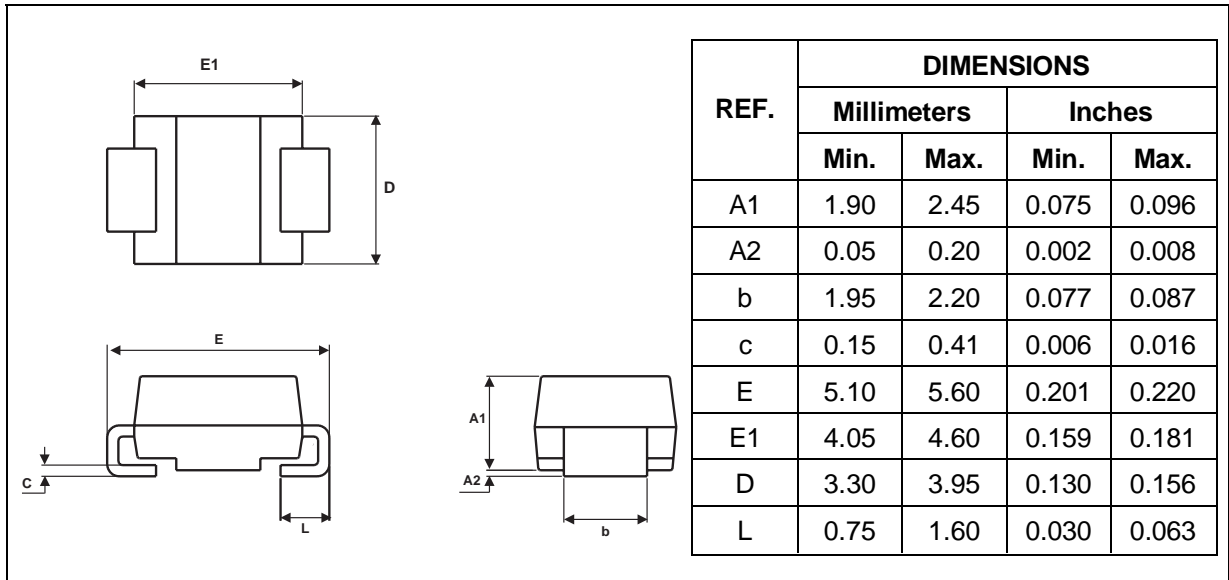


Turn-on losses :

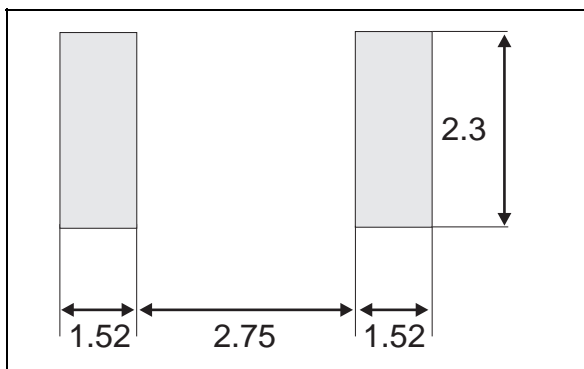
$$P4 = 0.4 (V_{FP} - V_F) \times I_{Fmax} \times t_{fr} \times F$$

PACKAGE MECHANICAL DATA

SMB



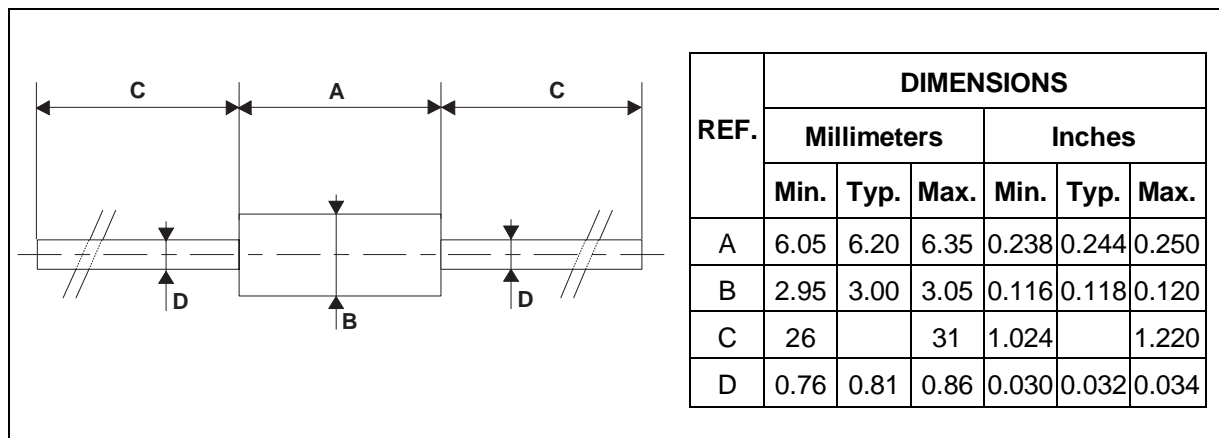
FOOTPRINT DIMENSIONS (in millimeters)



## STTA106/U

### PACKAGE MECHANICAL DATA

F126



### MARKING

Type	Marking	Package	Weight	Base Qty	Delivery mode
STTA106U	T01	SMB	0.11g	2500	tape & reel
STTA106	STTA106	F126	0.39g	1000	box
STTA106RL	STTA106	F126	0.39g	6000	tape & reel

- Band indicates cathode
- Epoxy meets UL94,V0

Information furnished is believed to be accurate and reliable. However, STMicroelectronics assumes no responsibility for the consequences of use of such information nor for any infringement of patents or other rights of third parties which may result from its use. No license is granted by implication or otherwise under any patent or patent rights of STMicroelectronics. Specifications mentioned in this publication are subject to change without notice. This publication supersedes and replaces all information previously supplied. STMicroelectronics products are not authorized for use as critical components in life support devices or systems without express written approval of STMicroelectronics.

The ST logo is a registered trademark of STMicroelectronics

© 1999 STMicroelectronics - Printed in Italy - All rights reserved.

STMicroelectronics GROUP OF COMPANIES

Australia - Brazil - China - Finland - France - Germany - Hong Kong - India - Italy - Japan - Malaysia  
Malta - Morocco - Singapore - Spain - Sweden - Switzerland - United Kingdom - U.S.A.

<http://www.st.com>