

### RV5C387A

#### 1. OUTLINE

The RV5C387A is a CMOS real-time clock IC connected to the CPU by two signal lines, SCL and SDA, and configured to perform serial transmission of time and calendar data to the CPU. The periodic interrupt circuit is configured to generate interrupt signals with six selectable interrupts ranging from 0.5 seconds to 1 month. The 2 alarm interrupt circuits generate interrupt signals at preset times. As the oscillation circuit is driven under constant voltage, fluctuation of the oscillator frequency due to supply voltage is small, and the time keeping current is small (TYP. 0.35  $\mu$ A at 3 volts). The oscillation halt sensing circuit can be used to judge the validity of internal data in such events as power-on; The supply voltage monitoring circuit is configured to record a drop in supply voltage below two selectable supply voltage monitoring threshold settings. The 32-kHz clock output function (Nch open-drain output) is intended to output sub-clock pulses for the external microcomputer. The 32-kHz clock output can be disabled by certain register settings. The oscillation adjustment circuit is intended to adjust time counts with high precision by correcting deviations in the oscillation frequency of the crystal oscillator. This model comes in an ultra-compact SSOP10G (Pin Pitch 0.5mm, Height1.2mm, 4.0mm $\times$ 2.9mm).

#### 2. FEATURES

- Timekeeping supply voltage ranging from 1.45 to 5.5V
- Low power consumption 0.35 $\mu$ A TYP (0.8 $\mu$ A MAX) at VDD=3V
- Only two signal lines (SCL and SDA) required for connection to the CPU.  
( I<sup>2</sup>C-Bus Interface, 400kHz at VDD $\geq$ 2.5V, address7bit)
- Time counters (counting hours, minutes, and seconds) and calendar counters (counting years, months, days, and weeks) (in BCD format)
- 1900/2000 identification bit for Year 2000 compliance
- Interrupt circuit configured to generate interrupt signals (with interrupts ranging from 0.5 seconds to 1 month) to the CPU and provided with an interrupt flag and an interrupt halt
- 2 alarm interrupt circuits (Alarm\_W for week, hour, and minute alarm settings and Alarm\_D for hour and minute alarm settings)
- 32-kHz clock circuit (N-ch open-drain output)  
Designed to disable 32-kHz clock output in response to a command from the host computer.
- Oscillation halt sensing circuit which can be used to judge the validity of internal data
- Supply voltage monitoring circuit with two supply voltage monitoring threshold settings
- Automatic identification of leap years up to the year 2099
- Selectable 12-hour and 24-hour mode settings
- High precision oscillation adjustment circuit
- CMOS process
- Built-in oscillation stabilization capacitors (CG and CD)
- Ultra-compact SSOP10G

\*) I<sup>2</sup>C-Bus is a trademark of PHILIPS N.V.

Purchase of I<sup>2</sup>C-Bus components of Ricoh Company, LTD. conveys a license under the Philips I<sup>2</sup>C Patent Rights to use these components in an I<sup>2</sup>C system, provided that the system conforms to the I<sup>2</sup>C standard Specification as defined by Philips.

3. PIN CONFIGURATION

RV5C387A (SSOP10G)

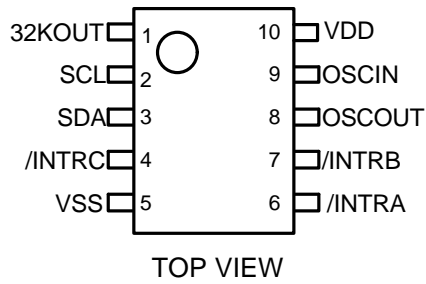

4. BLOCK DIAGRAM

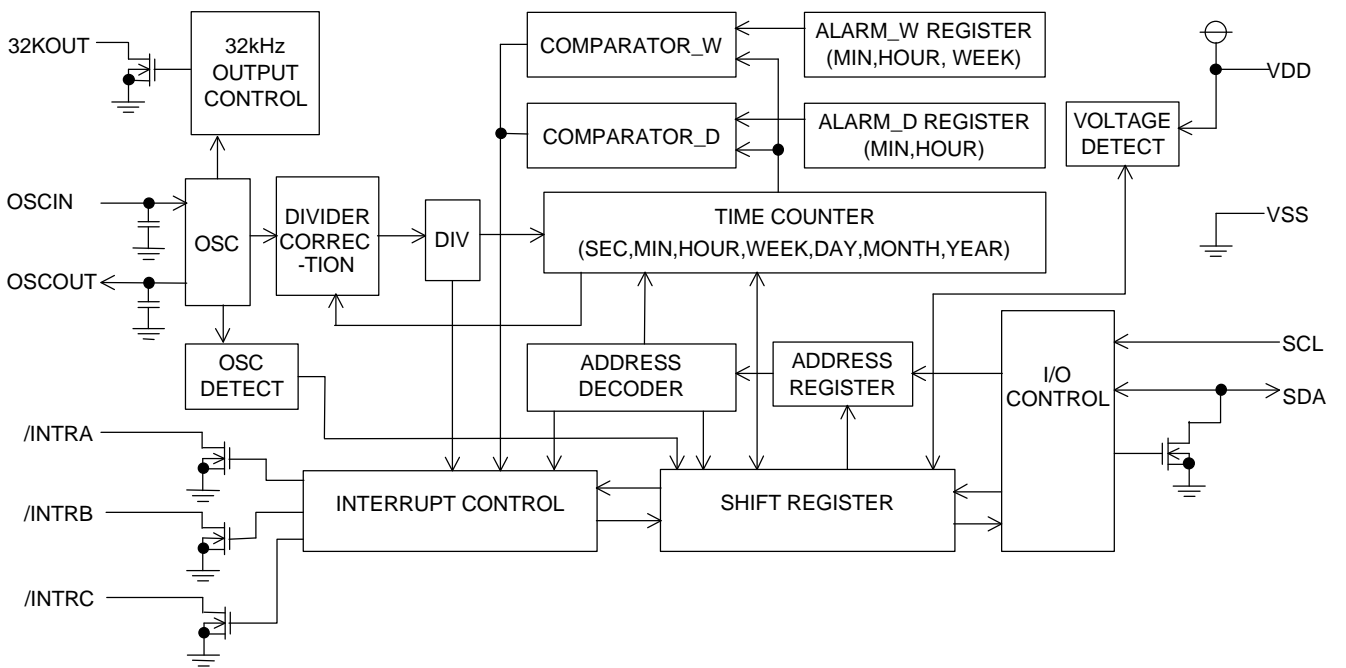

## 5. PIN DESCRIPTION

Symbol	Item	Description
SCL	Serial Clock Line	The SCL pin is used to input clock pulses synchronizing the input and output of data to and from the SDA pin. Allows a maximum input voltage of 5.5 volts regardless of supply voltage.
SDA	Serial Data Line	The SDA pin is used to input or output data intended for writing or reading in synchronization with the SCL pin. Up to 5.5v beyond VDD may be input. This pin functions as an Nch open drain output.
/INTRA	Interrupt Output A	The /INTRA pin is used to output periodic interrupt signals to the CPU. Disabled at power-on from 0 volts. Nch. open drain output.
/INTRB	Interrupt Output B	The /INTRB pin is used to output alarm interrupt (Alarm_W) signals to the CPU. Disabled at power-on from 0 volts. Nch. open drain output.
/INTRC	Interrupt Output C	The /INTRC pin is used to output alarm interrupt (Alarm_D) signals to the CPU. Disabled at power-on from 0 volts. Nch. open drain output.
32KOUT	32kHz Clock Output	The 32KOUT pin is used to output 32.768-kHz clock pulses. Enabled at power-on from 0 volts. Nch. open drain output. The RV5C387A is designed to disable 32-kHz clock output in response to a command from the host computer.
OSCIN OSCOUT	Oscillation Circuit Input / Output	The OSCIN and OSCOUT pins are used to connect the 32.768-kHz crystal oscillator (with all other oscillation circuit components built into the RV5C387A).
VDD	Positive Power Supply Input	The VDD pin is connected to the power supply.
VSS	Negative Power Supply Input	The VSS pin is grounded.

## 6. ABSOLUTE MAXIMUM RATINGS

(VSS=0V)

Symbol	Item	Pin Name	Description	Unit
VDD	Supply Voltage		-0.3 to +6.5	V
VI	Input Voltage	SCL, SDA	-0.3 to +6.5	V
VO	Output Voltage	32KOUT, SDA, /INTRA, /INTRB, /INTRC	-0.3 to +6.5	V
PD	Power Dissipation	T <sub>opt</sub> = 25°C	300	mW
T <sub>opt</sub>	Operating Temperature		-40 to +85	°C
T <sub>stg</sub>	Storage Temperature		-55 to +125	°C

## 7. RECOMMENDED OPERATING CONDITIONS

(VSS=0V, T<sub>opt</sub>=-40 to +85°C)

Symbol	Item	Pin Name	Min.	Typ.	Max.	Unit
VDD	Supply Voltage		2.0		5.5	V
VCLK	Timekeeping Voltage		1.45		5.5	V
fXT	Oscillation Frequency			32.768		kHz
VPUP	Pull-up Voltage	SCL, SDA, /INTRA, /INTRB, /INTRC			5.5	V

## 8. DC ELECTRICAL CHARACTERISTICS

(Unless otherwise specified : VSS=0V, VDD=3V, T<sub>opt</sub>=-40 to +85°C)

Symbol	Item	Pin Name	Conditions	Min.	Typ.	Max.	Unit
VIH	"H" Input Voltage	SCL, SDA	VDD=2.0 to 5.5V	0.8VDD		5.5	V
VIL	"L" Input Voltage			-0.3		0.2VDD	
IOL1	"L" Output Current	32KOUT	VOL=0.4V	0.5			mA
IOL2		/INTRA, /INTRB, /INTRC		1.0			
IOL3		SDA		4.0			
IIL		Input Leakage Current		SCL	VI=5.5V or VSS VDD=5.5V	-1	
IOZ	Output Off-state Current	SDA, /INTRA, /INTRB, /INTRC	VO=5.5V or VSS VDD=5.5V	-1		1	μA
IDD	Time Keeping Current	VDD	VDD=3V, SCL=SDA=3V, Output = OPEN 32KOUT=OFF mode *1)		0.35	0.8	μA
VDETH	Supply Voltage Monitoring Voltage "H"	VDD	T <sub>opt</sub> =-30 to +70°C	1.90	2.10	2.30	V
VDETL	Supply Voltage Monitoring Voltage "L"	VDD	T <sub>opt</sub> =-30 to +70°C	1.45	1.60	1.80	V
CG	Internal Oscillation Capacitance 1	OSCIN			12		pF
CD	Internal Oscillation Capacitance 2	OSCOUT			12		

\*1) For Standby Current for outputting 32.768kHz clock pulses from the 32KOUT pin, see, "14.7 Typical Characteristics".

9. AC ELECTRICAL CHARACTERISTICS

Unless otherwise specified :  $V_{SS}=0V, T_{opt}=-40$  to  $+85^{\circ}C$

Input and Output Conditions :  $V_{IH}=0.8 \times V_{DD}, V_{IL}=0.2 \times V_{DD}, V_{OH}=0.8 \times V_{DD}, V_{OL}=0.2 \times V_{DD}, C_L=50pF$

Symbol	Item	Condi- tions	VDD≥2.0V			VDD≥2.5V			Unit
			Min.	Typ.	Max.	Min.	Typ.	Max.	
$f_{SCL}$	SCL Clock Frequency				100			400	KHz
$t_{LOW}$	SCL Clock Low Time		4.7			1.3			$\mu s$
$t_{HIGH}$	SCL Clock High Time		4.0			0.6			$\mu s$
$t_{HD:STA}$	Start Condition Hold Time		4.0			0.6			$\mu s$
$t_{SU:STO}$	Stop Condition Set Up Time		4.0			0.6			$\mu s$
$t_{SU:STA}$	Start Condition Set Up Time		4.7			0.6			$\mu s$
$t_{SU:DAT}$	Data Set Up Time		250			200			ns
$t_{HD:DAT}$	Data Hold Time		0			0			ns
$t_{PL:DAT}$	SDA "L" Stable Time After Falling of SCL				2.0			0.9	$\mu s$
$t_{PZ:DAT}$	SDA off Stable Time After Falling of SCL				2.0			0.9	$\mu s$
$t_R$	Rising Time of SCL and SDA (input)				1000			300	ns
$t_F$	Falling Time of SCL and SDA (input)				300			300	ns
$t_{SP}$	Spike Width that can be removed with Input Filter				50			50	ns

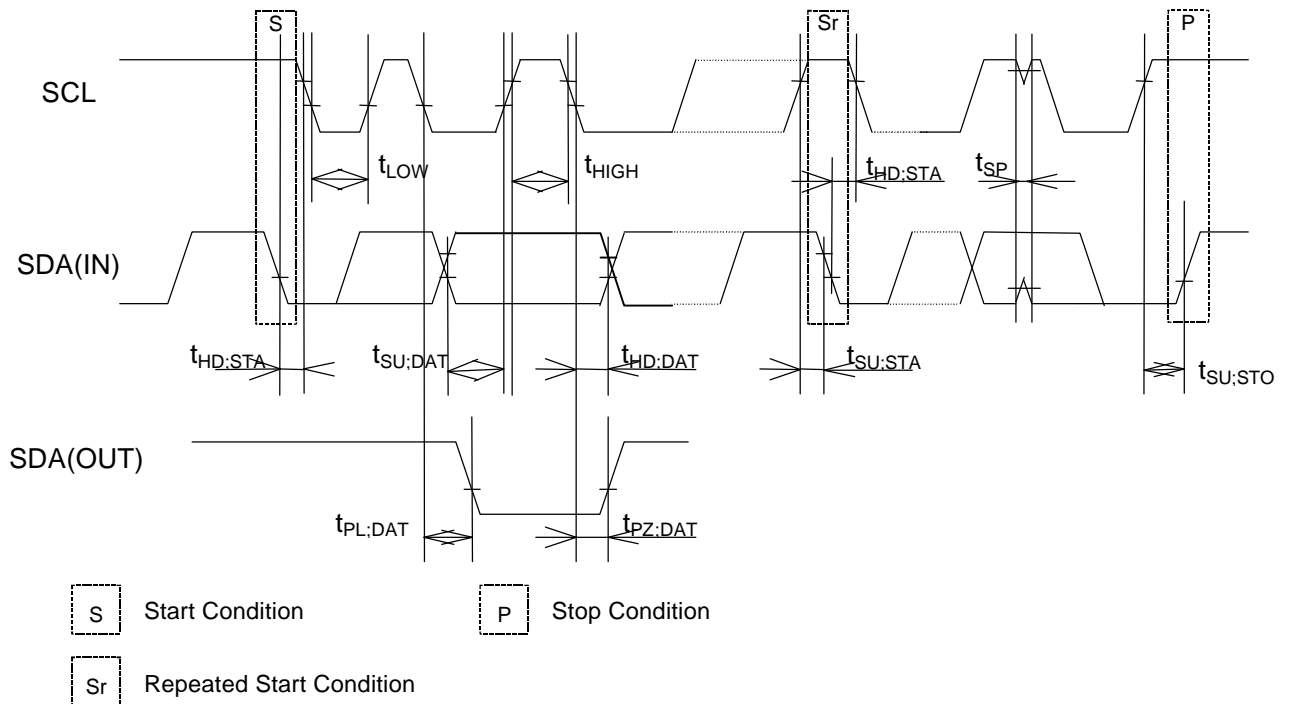

10. PACKAGE DIMENSIONS (Unit : mm)  
RV5C387A (SSOP10G)

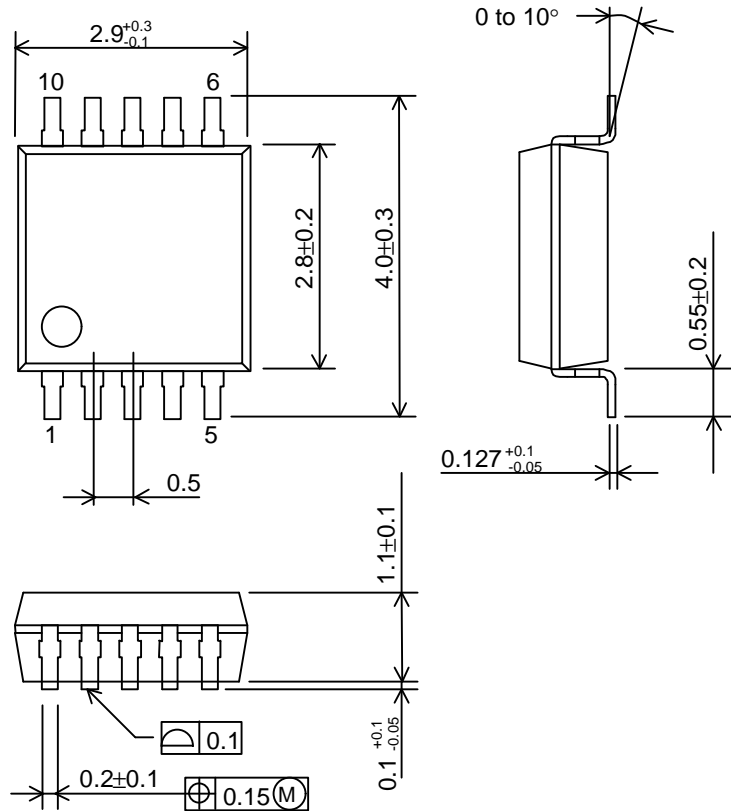

11. TAPING SPECIFICATION

The RV5C387A has one designated taping direction. The product designation for the taping components is "RV5C387A-E2".

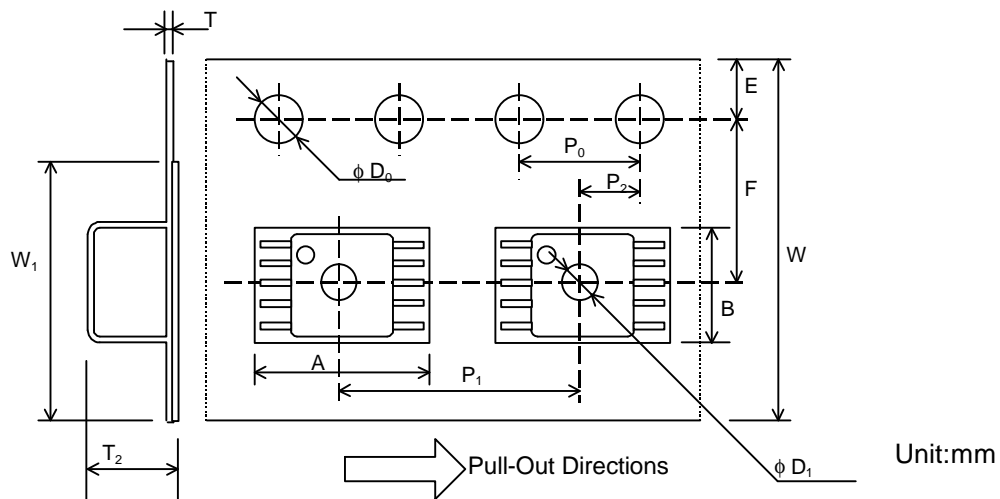

A	B	D <sub>0</sub>	D <sub>1</sub>	E	F	P <sub>0</sub>	P <sub>1</sub>	P <sub>2</sub>	T	T <sub>2</sub>	W	W <sub>1</sub>
4.4	3.2	1.5	1.5	1.75	5.5	4.0	8.0	2.0	0.3	2.0	12.0	9.5
±0.1	±0.1	+0.1 -0	+0.1 -0	±0.1	±0.05	±0.1	±0.1	±0.05	±0.05	(MAX)	±0.3	

## 12. GENERAL DESCRIPTION

### (1) Interface with CPU

The RV5C387A is connected to the CPU by two signal lines SCL and SDA, through which it reads and writes data from and to the CPU. Since the output of the I/O pin of SDA is open drain, data interfacing with a CPU different supply voltage is possible by applying pull-up resistors on the circuit board. The maximum clock frequency of 400kHz (at  $VDD \geq 2.5V$ ) of SCL enables data transfer in I<sup>2</sup>C-Bus fast mode.

### (2) Clock and Calendar Function

The RV5C387A reads and writes time data from and to the CPU in units ranging from seconds to the last two digits of the calendar year. The calendar year will automatically be identified as a leap year when its last two digits are a multiple of 4. Also available is the 1900 / 2000 identification bit for Year 2000 compliance. Consequently, leap years up to the year 2099 can automatically be identified as such.

\*) The year 2000 is a leap year while the year 2100 is not a leap year.

### (3) Alarm Function

The RV5C387A incorporates the alarm interrupt circuit configured to generate interrupt signals to the CPU at preset times. The alarm interrupt circuit allows two types of alarm settings specified by the Alarm\_W registers and the Alarm\_D registers. The Alarm\_W registers allow week, hour, and minute alarm settings including combinations of multiple day-of-week settings such as "Monday, Wednesday, and Friday" and "Saturday and Sunday". The Alarm\_D registers allow hour and minute alarm settings. The Alarm\_W outputs from /INTRB pin, and the Alarm\_D outputs from /INTRC pin. The current /INTRB or /INTRC conditions specified by the flag bits for each alarm function can be checked from the CPU by using a polling function.

### (4) High-precision Oscillation Adjustment Function

The RV5C387A has built-in oscillation stabilization capacitors (CG and CD), which can be connected to an external crystal oscillator to configure an oscillation circuit. To correct deviations in the oscillation frequency of the crystal oscillator, the oscillation adjustment circuit is configured to allow correction of a time count gain or loss (up to  $\pm 1.5$  ppm at 25°C) from the CPU within a maximum range of approximately + 189 ppm in increments of approximately 3 ppm. Such oscillation frequency adjustment in each system has the following advantages:

- \* Allows timekeeping with much higher precision than conventional RTCs while using a crystal oscillator with a wide range of precision variations.
- \* Corrects seasonal frequency deviations through seasonal oscillation adjustment.
- \* Allows timekeeping with higher precision particularly with a temperature sensing function out of RTC, through oscillation adjustment in tune with temperature fluctuations.

### (5) Oscillation Halt Sensing Function and Supply Voltage Monitoring Function

The RV5C387A incorporates an oscillation halt sensing circuit equipped with internal registers configured to record any past oscillation halt, thereby identifying whether they are powered on from 0 volts or battery backed-up. As such, the oscillation halt sensing circuit is useful for judging the validity of time data.

The RV5C387A also incorporates a supply voltage monitoring circuit equipped with internal registers configured to record any drop in supply voltage below a certain threshold value. Supply voltage monitoring threshold settings can be selected between 2.1 and 1.6 volts through internal register settings. The oscillation halt sensing circuit is configured to confirm the established invalidation of time data in contrast to the supply voltage monitoring circuit intended to confirm the potential invalidation of time data. Further, the supply voltage monitoring circuit can be applied to battery supply voltage monitoring.

(6) Periodic Interrupt Function

The RV5C387A incorporates the periodic interrupt circuit configured to generate periodic interrupt signals aside from interrupt signals generated by the alarm interrupt circuit for output from the /INTRA pin. Periodic interrupt signals have five selectable frequency settings of 2 Hz (once per 0.5 seconds), 1 Hz (once per 1 second), 1/60 Hz (once per 1 minute), 1/3600 Hz (once per 1 hour), and monthly (the first day of every month). Further, periodic interrupt signals also have two selectable waveforms, a normal pulse form (with a frequency of 2 Hz or 1 Hz) and special form adapted to interruption from the CPU in the level mode (with second, minute, hour, and month interrupts). The condition of periodic interrupt signals can be monitored by using a polling function.

(7) 32kHz Clock Output

The RV5C387A incorporates a 32-kHz clock circuit configured to generate clock pulses with the oscillation frequency of a 32.768kHz crystal oscillator for output from the 32KOUT pin (Nch open drain output). The 32-kHz clock output can be disabled by certain register settings but cannot be disabled without manipulation of any two registers with different addresses to prevent disabling in such events as the runaway of the CPU. The 32KOUT pin is enabled at power-on from 0 volts.



## 13. FUNCTION DESCRIPTIONS

## 13.1. Address Mapping

	Address	Register Name	Data							
	A3A2A1A0		D7	D6	D5	D4	D3	D2	D1	D0
0	0 0 0 0	Second Counter	- *2)	S40	S20	S10	S8	S4	S2	S1
1	0 0 0 1	Minute Counter	-	M40	M20	M10	M8	M4	M2	M1
2	0 0 1 0	Hour Counter	-	-	H20 P-/A	H10	H8	H4	H2	H1
3	0 0 1 1	Day-of-week Counter	-	-	-	-	-	W4	W2	W1
4	0 1 0 0	Day-of-month Counter	-	-	D20	D10	D8	D4	D2	D1
5	0 1 0 1	Month Counter and Century Bit	/19-20	-	-	MO10	MO8	MO4	MO2	MO1
6	0 1 1 0	Year Counter	Y80	Y40	Y20	Y10	Y8	Y4	Y2	Y1
7	0 1 1 1	Oscillation Adjustment Register *3)	-	F6	F5	F4	F3	F2	F1	F0
8	1 0 0 0	Alarm_W (Minute Register)	-	WM40	WM20	WM10	WM8	WM4	WM2	WM1
9	1 0 0 1	Alarm_W (Hour Register)	-	-	WH20 WP-/A	WH10	WH8	WH4	WH2	WH1
A	1 0 1 0	Alarm_W (Day-of-week Register)	-	WW6	WW5	WW4	WW3	WW2	WW1	WW0
B	1 0 1 1	Alarm_D (Minute Register)	-	DM40	DM20	DM10	DM8	DM4	DM2	DM1
C	1 1 0 0	Alarm_D (Hour Register)	-	-	DH20 DP-/A	DH10	DH8	DH4	DH2	DH1
D	1 1 0 1		-	-	-	-	-	-	-	-
E	1 1 1 0	Control Register 1 *3)	WALE	DALE	/12-24	/CLEN2	TEST	CT2	CT1	CT0
F	1 1 1 1	Control Register 2 *3)	VDSL	VDET	SCRA- TCH	XSTP	/CLEN1	CTFG	WAFG	DAFG

## Notes:

- \* 1) All the data listed above accept both reading and writing.
- \* 2) The data marked with "-" is invalid for writing and reset to 0 for reading.
- \* 3) When the XSTP bit is set to 1 in Control Register 2, all the bits are reset to 0 in Oscillation Adjustment Register, Control Register 1 and Control Register 2 excluding the XSTP bit.

13.2. Register Settings

13.2.1. Control Register 1 (ADDRESS Eh)

D7	D6	D5	D4	D3	D2	D1	D0	
WALE	DALE	/12-24	/CLEN2	TEST	CT2	CT1	CT0	(For Writing)
WALE	DALE	/12-24	/CLEN2	TEST	CT2	CT1	CT0	(For Reading)
0	0	0	0	0	0	0	0	Default Settings *)

\*) Default settings: Default value means read/written values when the XSTP bit is set to "1" due to power-on from 0 volts or supply voltage drop.

(1) WALE, DALE Alarm\_W Enable Bit, Alarm\_D Enable Bit

WALE,DALE	Description	
0	Disabling the alarm interrupt circuit (under the control of the settings of the Alarm_W registers and the Alarm_D registers).	(Default)
1	Enabling the alarm interrupt circuit (under the control of the settings of the Alarm_W registers and the Alarm_D registers)	

(2) /12-24 12-/24-hour Mode Selection Bit

/12-24	Description	
0	Selecting the 12-hour mode with a.m. and p.m. indications.	(Default)
1	Selecting the 24-hour mode	

Setting the /12-24 bit to 0 and 1 specifies the 12-hour mode and the 24-hour mode, respectively.

24-hour mode	12-hour mode	24-hour mode	12-hour mode
00	12 (AM12)	12	32 (PM12)
01	01 (AM 1)	13	21 (PM 1)
02	02 (AM 2)	14	22 (PM 2)
03	03 (AM 3)	15	23 (PM 3)
04	04 (AM 4)	16	24 (PM 4)
05	05 (AM 5)	17	25 (PM 5)
06	06 (AM 6)	18	26 (PM 6)
07	07 (AM 7)	19	27 (PM 7)
08	08 (AM 8)	20	28 (PM 8)
09	09 (AM 9)	21	29 (PM 9)
10	10 (AM10)	22	30 (PM10)
11	11 (AM11)	23	31 (PM11)

Setting the /12-24 bit should precede writing time data

(3) /CLEN2 32-kHz Clock Output Bit 2

/CLEN2	Description	
0	Enabling the 32-kHz clock circuit	(Default)
1	Disabling the 32-kHz clock circuit	

Setting the /CLEN2 bit or the /CLEN1 bit (D3 in the control register 2) to 0 specifies generating clock pulses with the oscillation frequency of the 32.768-kHz crystal oscillator for output from the 32KOUT pin. Conversely, setting both the /CLEN1 and the /CLEN2 bit to 1 specifies disabling ("H") such output.

(4) TEST Test Bit

TEST	Description	
0	Normal operation mode.	(Default)
1	Test mode.	

The TEST bit is used only for testing in the factory and should normally be set to 0.

(5) CT2,CT1, and CT0 Periodic Interrupt Selection Bits

CT2	CT1	CT0	Description	
			Wave form mode	Interrupt Cycle and Falling Timing
0	0	0	-	OFF(H)
0	0	1	-	Fixed at "L"
0	1	0	Pulse Mode *1)	2Hz(Duty50%)
0	1	1	Pulse Mode *1)	1Hz(Duty50%)
1	0	0	Level Mode *2)	Once per 1 second (Synchronized with second counter increment)
1	0	1	Level Mode *2)	Once per 1 minute (at 00 seconds of every minute)
1	1	0	Level Mode *2)	Once per hour (at 00 minutes and 00 seconds of every hour)
1	1	1	Level Mode *2)	Once per month (at 00 hours, 00 minutes, and 00 seconds of first day of every month)

(Default)

\*1) Pulse Mode: 2-Hz and 1-Hz clock pulses are output in synchronization with the increment of the second counter as illustrated in the timing chart below.

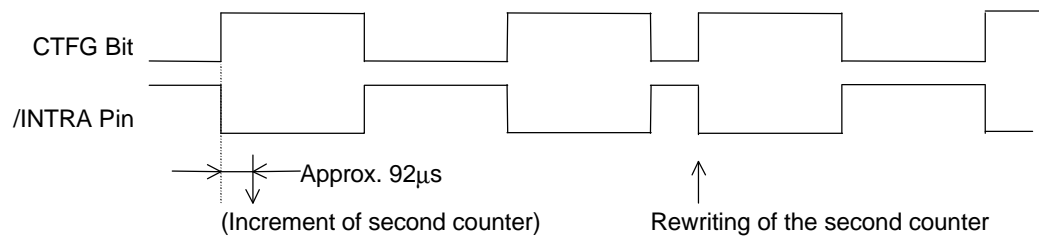

In the pulse mode, the increment of the second counter is delayed by approximately 92 µs from the falling edge of clock pulses. Consequently, time readings immediately after the falling edge of clock pulses may appear to lag behind the time counts of the real-time clocks by approximately 1 second. Rewriting the second counter will reset the other time counters of less than 1 second, driving the /INTRA pin low.

\*2) Level Mode: Periodic interrupt signals are output with selectable interrupt cycle settings of 1 second, 1 minute, 1 hour, and 1 month. The increment of the second counter is synchronized with the falling edge of periodic interrupt signals. For example, periodic interrupt signals with an interrupt cycle setting of 1 second are output in synchronization with the increment of the second counter as illustrated in the timing chart below.

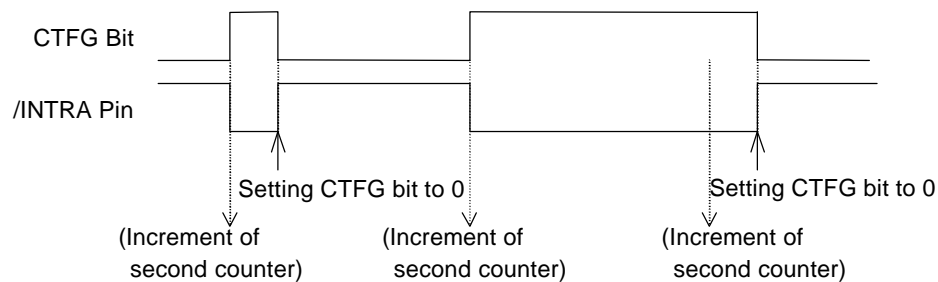

\*1), \*2) When the oscillation adjustment circuit is used, the interrupt cycle will fluctuate once per 20sec. as follows:  
 Pulse Mode: The "L" period of output pulses will increment or decrement by a maximum of ±3.784 ms. For example, 1-Hz clock pulses will have a duty cycle of 50 ±0.3784%.  
 Level Mode: A periodic interrupt cycle of 1 second will increment or decrement by a maximum of ±3.784 ms.

13.2.2. Control Register 2 (Address Fh)

D7	D6	D5	D4	D3	D2	D1	D0	
VDSL	VDET	SCRATCH	XSTP	/CLEN1	CTFG	WAFG	DAFG	(For Writing)
VDSL	VDET	SCRATCH	XSTP	/CLEN1	CTFG	WAFG	DAFG	(For Reading)
0	0	0	1	0	0	0	0	Default Settings *)

\*) Default settings: Default value means read / written values when the XSTP bit is reset due to power-on from 0 volts or supply voltage drop.

(1) VDSL Supply Voltage Monitoring Threshold Selection Bit

VDSL	Description	
0	Selecting the supply voltage monitoring threshold setting of 2.1v.	(Default)
1	Selecting the supply voltage monitoring threshold setting of 1.6v.	

The VDSL bit is intended to select the supply voltage monitoring threshold settings.

(2) VDET Supply Voltage Monitoring Result Indication Bit

VDET	Description	
0	Indicating supply voltage above the supply voltage monitoring threshold settings.	(Default)
1	Indicating supply voltage below the supply voltage monitoring threshold settings.	

Once the VDET bit is set to 1, the supply voltage monitoring circuit will be disabled while the VDET bit will hold the setting of 1. The VDET bit accepts only the writing of 0, which restarts the supply voltage monitoring circuit. Conversely, setting the VDET bit to 1 causes no event.

(3) SCRATCH Scratch Bit

SCRATCH	Description	
0		(Default)
1		

The SCRATCH bit is intended for scratching and accepts the reading and writing of 0 and 1. The SCRATCH bit will be set to 0 when the XSTP bit is set to 1 in the Control Register 2.

(4) XSTP Oscillation Halt Sensing Bit

XSTP	Description	
0	Sensing a normal condition of oscillation	
1	Sensing a halt of oscillation	(Default)

The XSTP bit is for sensing a halt in the oscillation of the crystal oscillator.

- \* The XSTP bit will be set to 1 once a halt in the oscillation of the crystal oscillator is caused by such events as power-on from 0 volts and a drop in supply voltage. The XSTP bit will hold the setting of 1 even after the restart of oscillation. As such, the XSTP bit can be applied to judge the validity of clock and calendar data after power-on or a drop in supply voltage.
- \* When the XSTP bit is set to 1, all bits will be reset to 0 in the Oscillation Adjustment Register, Control Register 1, and Control Register 2, stopping the output from /INTRA, /INTRB, and /INTRC pins and starting the output of 32.768-kHz clock pulses from the 32KOUT pin.
- \* The XSTP bit accepts only the writing of 0, which restarts the oscillation halt sensing circuit. Conversely, setting the XSTP bit to 1 causes no event.
- \* It is recommendable to frequently check the XSTP bit for setting errors or data garbles, which may seriously affect the operation of the RV5C387A.

(5) /CLEN1 32-kHz Clock Output Bit 1

/CLEN1	Description
0	Enabling the 32-kHz clock output
1	Disabling the 32-kHz clock output

(Default)

Setting the /CLEN1 bit or the /CLEN2 bit (D4 in control register 1) to 0 specifies generating clock pulses with the oscillation frequency of the 32.768-kHz crystal oscillator for output from the 32KOUT pin. Conversely, setting both the /CLEN1 bit and the /CLEN2 bit to 1 specifies disabling (“H”) such output.

(6) CTFG Periodic Interrupt Flag Bit

CTFG	Description
0	Periodic interrupt output = “H”
1	Periodic interrupt output = “L”

(Default)

The CTFG bit is set to 1 when the periodic interrupt signals are output from the /INTRA pin (“L”). The CTFG bit accepts only the writing of 0 in the level mode, which disables (“H”) the /INTRA pin until it is enabled (“L”) again in the next interrupt cycle. Conversely, setting the CTFG bit to 1 causes no event.

(7) WAFG,DAFG Alarm\_W Flag Bit and Alarm\_D Flag Bit

WAFG,DAFG	Description
0	Indicating a mismatch between current time and preset alarm time
1	Indicating a match between current time and preset alarm time

(Default)

The WAFG and DAFG bits are valid only when the WALE and DALE have the setting of 1, which is caused approximately 61μs after any match between current time and preset alarm time specified by the Alarm\_W registers and the Alarm\_D registers. The WAFG (DAFG) bit accepts only the writing of 0. /INTRB (/INTRC) pin outputs off (“H”) when this bit is set to 0. And /INTRB (/INTRC) pin outputs “L” again at the next preset alarm time. Conversely, setting the WAFG and DAFG bits to 1 causes no event. The WAFG and DAFG bits will have the reading of 0 when the alarm interrupt circuit is disabled with the WALE and DALE bits set to 0. The settings of the WAFG and DAFG bits are synchronized with the output of the /INTRB (/INTRC) pin as shown in the timing chart below.

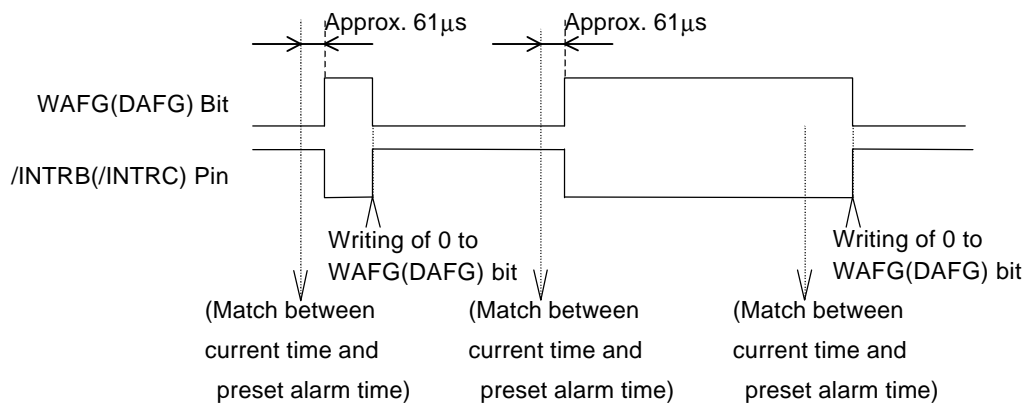

13.2.3. Time Counter (Address 0-2h)

- Second Counter (Address 0h)

D7	D6	D5	D4	D3	D2	D1	D0	
-	S40	S20	S10	S8	S4	S2	S1	(For Writing)
0	S40	S20	S10	S8	S4	S2	S1	(For Reading)
0	Indefinite	Indefinite	Indefinite	Indefinite	Indefinite	Indefinite	Indefinite	Default Settings *)

- Minute Counter (Address 1h)

D7	D6	D5	D4	D3	D2	D1	D0	
-	M40	M20	M10	M8	M4	M2	M1	(For Writing)
0	M40	M20	M10	M8	M4	M2	M1	(For Reading)
0	Indefinite	Indefinite	Indefinite	Indefinite	Indefinite	Indefinite	Indefinite	Default Settings *)

- Hour Counter (Address 2h)

D7	D6	D5	D4	D3	D2	D1	D0	
-	-	P-/A or H20	H10	H8	H4	H2	H1	(For Writing)
0	0	P-/A or H20	H10	H8	H4	H2	H1	(For Reading)
0	0	Indefinite	Indefinite	Indefinite	Indefinite	Indefinite	Indefinite	Default Settings *)

\*) Default settings: Default value means read/written values when the XSTP bit is set to "1" due to power-on from 0 volts or supply voltage drop.

\* Time digit display (BCD format) as follows:

The second digits range from 00 to 59 and are carried to the minute digit in transition from 59 to 00.

The minute digits range from 00 to 59 and are carried to the hour digits in transition from 59 to 00.

The hour digits range as shown in "13.2.1. – (2). /12-24: 12-/24-hour Mode Selection Bit" and are carried to the day-of-month and day-of-week digits in transition from PM11 to AM12 or from 23 to 00.

\* Any writing to the second counter resets divider units of less than 1 second.

\* Any carry from lower digits with the writing of non-existent time may cause the time counters to malfunction. Therefore, such incorrect writing should be replaced with the writing of existent time data.

13.2.4. Day-of-week Counter (Address 3h)

D7	D6	D5	D4	D3	D2	D1	D0	
-	-	-	-	-	W4	W2	W1	(For Writing)
0	0	0	0	0	W4	W2	W1	(For Reading)
0	0	0	0	0	Indefinite	Indefinite	Indefinite	Default Settings *)

\*) Default settings: Default value means read/written values when the XSTP bit is set to "1" due to power-on from 0 volts or supply voltage drop.

\* The day-of-week counter is incremented by 1 when the day-of-week digits are carried to the day-of-month digits.

\* Day-of-week display (incremented in septimal notation):

(W4, W2, W1) = (0, 0, 0) → (0, 0, 1) → ... → (1, 1, 0) → (0, 0, 0)

\* Correspondences between days of the week and the day-of-week digits are user-definable (e.g. Sunday = 0, 0, 0)

\* The writing of (1, 1, 1) to (W4, W2, W1) is prohibited except when days of the week are unused.

13.2.5. Calendar Counter (Address 4-6h)

- Day-of-month Counter (Address 4h)

D7	D6	D5	D4	D3	D2	D1	D0	
-	-	D20	D10	D8	D4	D2	D1	(For Writing)
0	0	D20	D10	D8	D4	D2	D1	(For Reading)
0	0	Indefinite	Indefinite	Indefinite	Indefinite	Indefinite	Indefinite	Default Settings *)

- Month Counter + Century Bit (Address 5h)

D7	D6	D5	D4	D3	D2	D1	D0	
/19-20	-	-	MO10	MO8	MO4	MO2	MO1	(For Writing)
/19-20	0	0	MO10	MO8	MO4	MO2	MO1	(For Reading)
Indefinite	0	0	Indefinite	Indefinite	Indefinite	Indefinite	Indefinite	Default Settings *)

- Year Counter (Address 6h)

D7	D6	D5	D4	D3	D2	D1	D0	
Y80	Y40	Y20	Y10	Y8	Y4	Y2	Y1	(For Writing)
Y80	Y40	Y20	Y10	Y8	Y4	Y2	Y1	(For Reading)
Indefinite	Indefinite	Indefinite	Indefinite	Indefinite	Indefinite	Indefinite	Indefinite	Default Settings *)

\*) Default settings: Default value means read/written values when the XSTP bit is set to "1" due to power-on from 0 volts or supply voltage drop.

\* The calendar counters are configured to display the calendar digits in BCD format by using the automatic calendar function as follows:

The day-of-month digits (D20 to D1) range from 1 to 31 for January, March, May, July, August, October, and December; from 1 to 30 for April, June, September, and November; from 1 to 29 for February in leap years; from 1 to 28 for February in ordinary years. The day-of-month digits are carried to the month digits in reversion from the last day of the month to 1. The month digits (MO10 to MO1) range from 1 to 12 and are carried to the year digits in reversion from 12 to 1.

The year digits (Y80 to Y1) range from 00 to 99 (00, 04, 08, ..., 92, and 96 in leap years) and are carried to the /19-20 digits in reversion from 99 to 00.

The /19-20 digits cycle between 0 and 1 in reversion from 99 to 00 in the year digits.

\* Any carry from lower digits with the writing of non-existent calendar data may cause the calendar counters to malfunction. Therefore, such incorrect writing should be replaced with the writing of existent calendar data.

13.2.6. Oscillation Adjustment Register (Address 7h)

D7	D6	D5	D4	D3	D2	D1	D0	
-	F6	F5	F4	F3	F2	F1	F0	(For Writing)
0	F6	F5	F4	F3	F2	F1	F0	(For Reading)
0	0	0	0	0	0	0	0	Default Settings *)

\*) Default settings: Default value means read/written values when the XSTP bit is set to "1" due to power-on from 0 volts or supply voltage drop.

F6 to F0 bits

The Oscillation Adjustment Circuit is configured to change time counts of 1 second on the basis of the settings of

of the Oscillation Adjustment Register when the second digits read 00, 20, or 40 seconds. Normally, the Second Counter is incremented once per 32768 32.768-kHz clock pulses generated by the crystal oscillator. Writing to the F6 to F0 bits activates the oscillation adjustment circuit.

- \* The Oscillation Adjustment Circuit will not operate with the same timing (00, 20, or 40 seconds) as the timing of writing to the Oscillation Adjustment Register.
- \* The F6 bit setting of 0 causes an increment of time counts by  $((F5, F4, F3, F2, F1, F0) - 1) \times 2$ . The F6 bit setting of 1 causes a decrement of time counts by  $((F5, F4, F3, F2, F1, F0) + 1) \times 2$ . The settings of "\*", 0, 0, 0, 0, 0, "\*" ("\*" representing either "0" or "1") in the F6, F5, F4, F3, F2, F1, and F0 bits cause neither an increment nor decrement of time counts.

Example:

When the second digits read 00, 20, or 40, the settings of "0, 0, 0, 0, 1, 1, 1" in the F6, F5, F4, F3, F2, F1, and F0 bits cause an increment of the current time counts of 32768 by  $(7 - 1) \times 2$  to 32780 (a current time count loss). When the second digits read 00, 20, or 40, the settings of "0, 0, 0, 0, 0, 0, 1" in the F6, F5, F4, F3, F2, F1, and F0 bits cause neither an increment nor a decrement of the current time counts of 32768.

When the second digits read 00, 20, or 40, the settings of "1, 1, 1, 1, 1, 1, 0" in the F6, F5, F4, F3, F2, F1, and F0 bits cause a decrement of the current time counts of 32768 by  $(-2) \times 2$  to 32764 (a current time count gain).

An increase of two clock pulses once per 20 seconds causes a time count loss of approximately 3 ppm ( $2 / (32768 \times 20) = 3.051$  ppm). Conversely, a decrease of two clock pulses once per 20 seconds causes a time count gain of 3 ppm. Consequently, deviations in time counts can be corrected with a precision of  $\pm 1.5$  ppm. Note that the oscillation adjustment circuit is configured to correct deviations in time counts and not the oscillation frequency of the 32.768-kHz clock pulses. For further details, see "14. 2. 4. Oscillation Adjustment Circuit".

13.2.7. Alarm\_W Registers (Address 8-Ah)

- Alarm\_W Minute Register (Address 8h)

D7	D6	D5	D4	D3	D2	D1	D0	
-	WM40	WM20	WM10	WM8	WM4	WM2	WM1	(For Writing)
0	WM40	WM20	WM10	WM8	WM4	WM2	WM1	(For Reading)
0	Indefinite	Indefinite	Indefinite	Indefinite	Indefinite	Indefinite	Indefinite	Default Settings *)

- Alarm\_W Hour Register (Address 9h)

D7	D6	D5	D4	D3	D2	D1	D0	
-	-	WH20 WP/A	WH10	WH8	WH4	WH2	WH1	(For Writing)
0	0	WH20 WP/A	WH10	WH8	WH4	WH2	WH1	(For Reading)
0	0	Indefinite	Indefinite	Indefinite	Indefinite	Indefinite	Indefinite	Default Settings *)

- Alarm\_W Day-of-week Register (Address Ah)

D7	D6	D5	D4	D3	D2	D1	D0	
-	WW6	WW5	WW4	WW3	WW2	WW1	WW0	(For Writing)
0	WW6	WW5	WW4	WW3	WW2	WW1	WW0	(For Reading)
0	Indefinite	Indefinite	Indefinite	Indefinite	Indefinite	Indefinite	Indefinite	Default Settings *)

\*) Default settings: Default value means read/written values when the XSTP bit is set to "1" due to power-on from 0 volts or supply voltage drop.

- \* The D5 bit of the Alarm\_W Hour Register represents WP/A when the 12-hour mode is selected (0 for a.m. and 1 for p.m.) and WH20 when the 24-hour mode is selected (tens in the hour digits).
- \* The Alarm\_W Registers should not have any non-existent alarm time settings.



(Note that any mismatch between current time and preset alarm time specified by the Alarm\_W registers may disable the alarm interrupt circuit.)

- \* When the 12-hour mode is selected, the hour digits read 12 and 32 for 0 a.m. and 0 p.m., respectively. (See "13.2. 1. – (2). /12 \* 24: 12-/24-hour Mode Selection Bit").
- \* WW0 to WW6 correspond to W4, W2, and W1 of the day-of-week counter with settings ranging from (0, 0, 0) to (1, 1, 0).
- \* WW0 to WW6 with respective settings of 0 disable the outputs of the Alarm\_W Registers.

Example of Alarm Time Setting

Alarm Preset alarm time	Day-of-week							12-hour mode				24-hour mode			
	Sun.	Mon.	Tue.	Wed.	Th.	Fri.	Sat.	10 hr.	1 hr.	10 min.	1 min.	10 hr.	1 hr.	10 min.	1 min.
	WW0	WW1	WW2	WW3	WW4	WW5	WW6								
00:00 a.m. on all days	1	1	1	1	1	1	1	1	2	0	0	0	0	0	0
01:30 a.m. on all days	1	1	1	1	1	1	1	0	1	3	0	0	1	3	0
11:59 a.m. on all days	1	1	1	1	1	1	1	1	1	5	9	1	1	5	9
00:00 p.m. on Mon. to Fri.	0	1	1	1	1	1	0	3	2	0	0	1	2	0	0
01:30 p.m. on Sun.	1	0	0	0	0	0	0	2	1	3	0	1	3	3	0
11:59 p.m. on Mon., Wed., and Fri.	0	1	0	1	0	1	0	3	1	5	9	2	3	5	9

Note that the correspondence between WW0 to WW6 and the days of the week shown in the above table is only an example and not mandatory.

13.2.8. Alarm\_D Register (Address B-Ch)

- Alarm\_D Minute Register (Address Bh)

D7	D6	D5	D4	D3	D2	D1	D0	
-	DM40	DM20	DM10	DM8	DM4	DM2	DM1	(For Writing)
0	DM40	DM20	DM10	DM8	DM4	DM2	DM1	(For Reading)
0	Indefinite	Indefinite	Indefinite	Indefinite	Indefinite	Indefinite	Indefinite	Default Settings *)

- Alarm\_D Hour Register (Address Ch)

D7	D6	D5	D4	D3	D2	D1	D0	
-	-	DH20 DP:/A	DH10	DH8	DH4	DH2	DH1	(For Writing)
0	0	DH20 DP:/A	DH10	DH8	DH4	DH2	DH1	(For Reading)
0	0	Indefinite	Indefinite	Indefinite	Indefinite	Indefinite	Indefinite	Default Settings *)

\*) Default settings: Default value means read/written values when the XSTP bit is set to "1" due to power-on from 0 volts or supply voltage drop.

- \* The D5 bit represents DP/A when the 12-hour mode is selected (0 for a.m. and 1 for p.m.) and DH20 when the 24-hour mode is selected (tens in the hour digits).
- \* The Alarm\_D registers should not have any non-existent alarm time settings. (Note that any mismatch between current time and preset alarm time specified by the Alarm\_D registers may disable the alarm interrupt circuit.)
- \* When the 12-hour mode is selected, the hour digits read 12 and 32 for 0a.m. and 0p.m., respectively. (see "13.2.1. (2) /12 \* 24: 12-/24-hour Mode Selection Bit").

14. USAGE

14.1. Interfacing with the CPU

The RV5C387A employs the I<sup>2</sup>C-Bus system to be connected to the CPU via 2-wires. Connection and system of I<sup>2</sup>C-Bus are described in the following sections.

14.1.1. Connection of I<sup>2</sup>C-Bus

2-wires, SCL and SDA pins that are connected to I<sup>2</sup>C-Bus are used for transmit clock pulses and data respectively. All ICs that are connected to these lines are designed that will not be clamped when a voltage beyond supply voltage is applied to input or output pins. Open drain pins are used for output. This construction allows communication of signals between ICs with different supply voltages by adding a pull-up resistor to each signal line as shown in the figure below. Each IC is designed not to affect SCL and SDA signal lines when power to each of these is turned off separately.

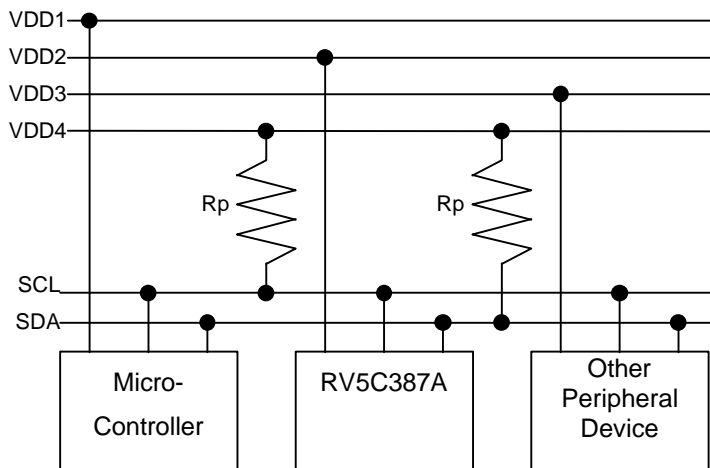

\* For data interface, the following conditions must be met:

- VDD4 ≥ VDD1
- VDD4 ≥ VDD2
- VDD4 ≥ VDD3

\* When the master is one, the micro-controller is ready for driving SCL to "H" and Rp of SCL may not be required.

Cautions on determining Rp resistance,

- (1) Dropping voltage at Rp due to sum of input current or output current at off conditions on each IC pin connected to the I<sup>2</sup>C-Bus shall be adequately small.
- (2) Rising time of each signal be kept short even when all capacity of the bus is driven.
- (3) Current consumed in I<sup>2</sup>C-Bus is small compared to the consumption current permitted for the entire system.

When all ICs connected to I<sup>2</sup>C-Bus are CMOS type, condition (1) may usually be ignored since input current and off-state output current is extremely small for the many CMOS type ICs. Thus the maximum resistance of Rp may be determined based on (2), while the minimum on (3) in most cases.

In actual cases a resistor may be place between the bus and input/output pins of each IC to improve noise margins in which case the Rp minimum value may be determined by the resistance.

Consumption current in the bus to review (3) above may be expressed by the formula below:

Bus consumption current ≈

$$\frac{(\text{Sum of input current and off state output current of all devices in standby mode}) \times \text{Bus standby duration}}{\text{Bus stand-by duration} + \text{the Bus operation duration}}$$

$$+ \frac{\text{Supply voltage} \times \text{Bus operation duration} \times 2}{\text{Rp resistance} \times 2 \times (\text{Bus stand-by duration} + \text{bus operation duration})}$$

$$+ \text{Supply voltage} \times \text{Bus capacity} \times \text{Charging/Discharging times per unit time}$$

Operation of "× 2" in the second member denominator in the above formula is derived from assumption that "L" duration of SDA and SCL pins are the half of bus operation duration. "× 2" in the numerator of the same member is because there are two pins of SDA and SCL. The third member, (charging/discharging times per unit time) means number of transition from "H" to "L" of the signal line.

Calculation example is shown below:

Pull-up resistor (Rp) = 10kΩ, Bus capacity = 50pF(both for SCL, SDA), Vdd=3v,  
 In a system with sum of input current and off-state output current of each pin = 0.1μA,  
 I<sup>2</sup>C-Bus is used for 10ms every second while the rest of 990ms in the stand-by mode,  
 In this mode, number of transitions of the SCL pin from “H” to “L” state is 100 while SDA 50, every second.

$$\begin{aligned} \text{Bus consumption current} &\approx \frac{0.1\mu\text{A} \times 990\text{msec}}{990\text{msec} + 10\text{msec}} \\ &+ \frac{3\text{V} \times 10\text{msec} \times 2}{10\text{K}\Omega \times 2 \times (990\text{msec} + 10\text{msec})} \\ &+ 3\text{V} \times 50\text{pF} \times (100 + 50) \\ &\approx 0.099\mu\text{A} + 3.0\mu\text{A} + 0.0225\mu\text{A} \approx 3.12\mu\text{A} \end{aligned}$$

Generally, the second member of the above formula is larger enough than the first and the third members, bus consumption current may be determined by the second member in many cases.

14.1.2. Transmission System of I<sup>2</sup>C-Bus

(1) Start Condition and Stop Condition

In I<sup>2</sup>C-Bus, SDA must be kept at a certain state while SCL is at the “H” state during data transmission as shown below.

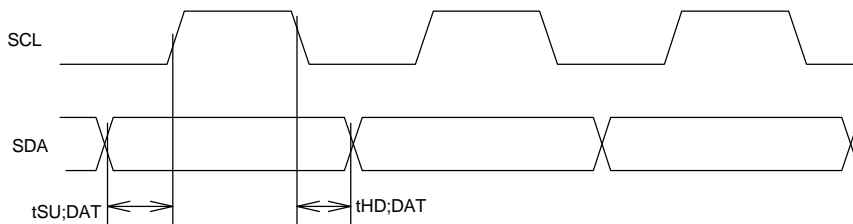

The SCL and SDA pins are at the “H” level when no data transmission is made. Changing the SDA from “H” to “L” when the SCL and the SDA are “H” activates the Start Condition and access is started. Changing the SDA from “L” to “H” when the SCL is “H” activates Stop Condition and accessing stopped. Generation of Start and Stop Conditions are always made by the master (see the figure below).

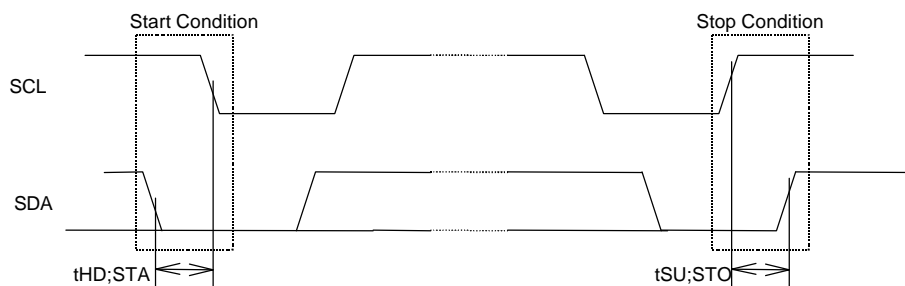

(2) Data transmission and its acknowledge

After Start condition is entered, data is transmitted by 1byte (8bits). Any bytes of data may be serially transmitted. The receiving side will send an acknowledge signal to the transmission side each time 8bit data is transmitted. The acknowledge signal is sent immediately after falling to “L” of SCL 8bit clock pulses of data is transmitted, by releasing the SDA by the transmission side that has asserted the bus at that time and by turning SDA to “L” by receiving side. When transmission of 1byte data next to preceding 1byte of data is received the receiving side releases the SDA pin at falling edge of the SCL 9bit of clock pulses or when the receiving side switches to the transmission side it starts data transmission. When the master is receiving side, it generates no acknowledge signal after last 1byte of data from the slave to tell the transmitter that data

transmission has completed. The slave side (transmission side) continues to release the SDA pin so that the master will be able to generate Stop Condition, after falling edge of the SCL 9bit of clock pulses.

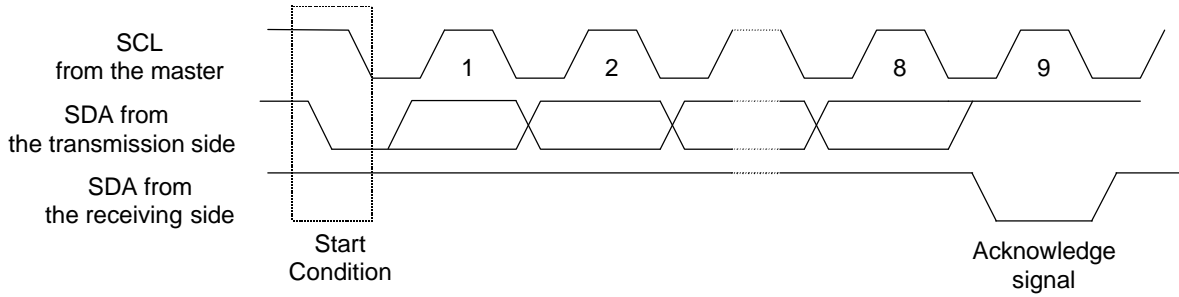

(3) Data Transmission Format in I<sup>2</sup>C-Bus

I<sup>2</sup>C-Bus has no chip enable signal line. In place of it, each device has a 7bit Slave Address allocated. The first 1byte is allocated to this 7bit address and to the command (R/W) for which data transmission direction is designated by the data transmission thereafter. 7bit address is sequentially transmitted from the MSB and 2 and after bytes are read, when 8bit is "H" and when write "L".

The Slave Address of the RV5C387A is specified at (0110010).

At the end of data transmission / receiving, Stop Condition is generated to complete transmission. However, if start condition is generated without generating Stop Condition, Repeated Start Condition is met and transmission / receiving data may be continue by setting the Slave Address again. Use this procedure when the transmission direction needs to be change during one transmission.

Data is written to the slave from the master

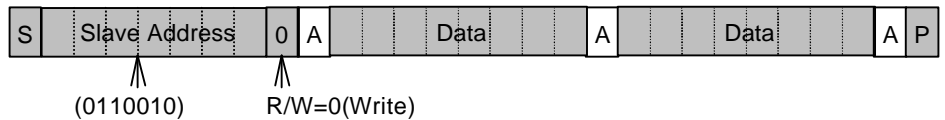

When data is read from the slave immediately after 7bit addressing from the master

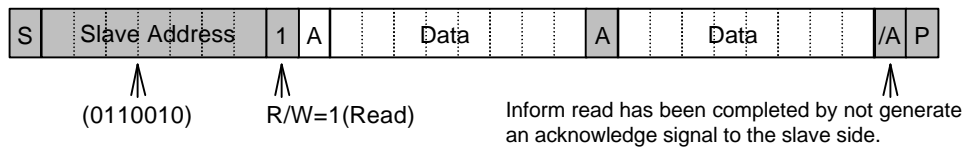

When the transmission direction is to be changed during transmission.

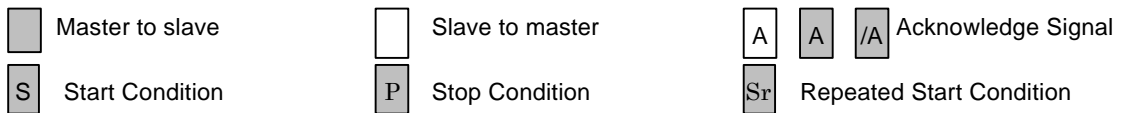
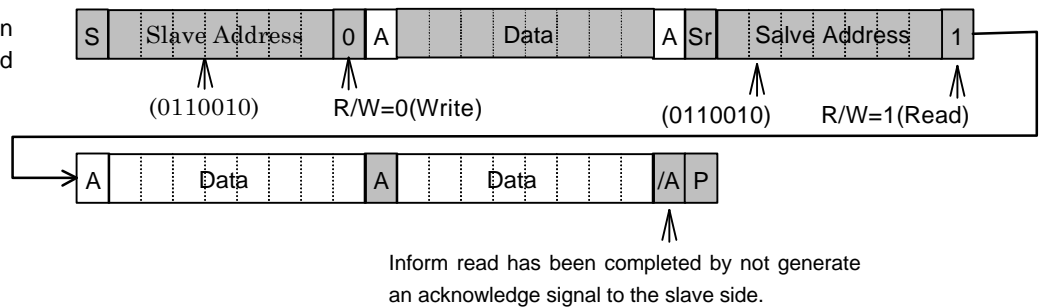

14.1.3. Data Transmission Write Format in the RV5C387A

Although the I<sup>2</sup>C-Bus standard defines a transmission format for the slave allocated for each IC, transmission method of address information in IC is not defined. The RV5C387A transmits data the internal address pointer (4bit) and the Transmission Format Register (4bit) at the 1byte next to one which transmitted a Slave Address and a write command. For write operation only one transmission format is available and (0000) is set to the Transmission Format Register. The 3byte transmits data to the address specified by the internal address pointer written to the 2byte. Internal address pointer setting are automatically incremented for 4byte and after. Note that when the internal address pointer is Fh, it will change to 0h on transmitting the next byte.

Example of data writing (When writing to internal address Eh to Fh)

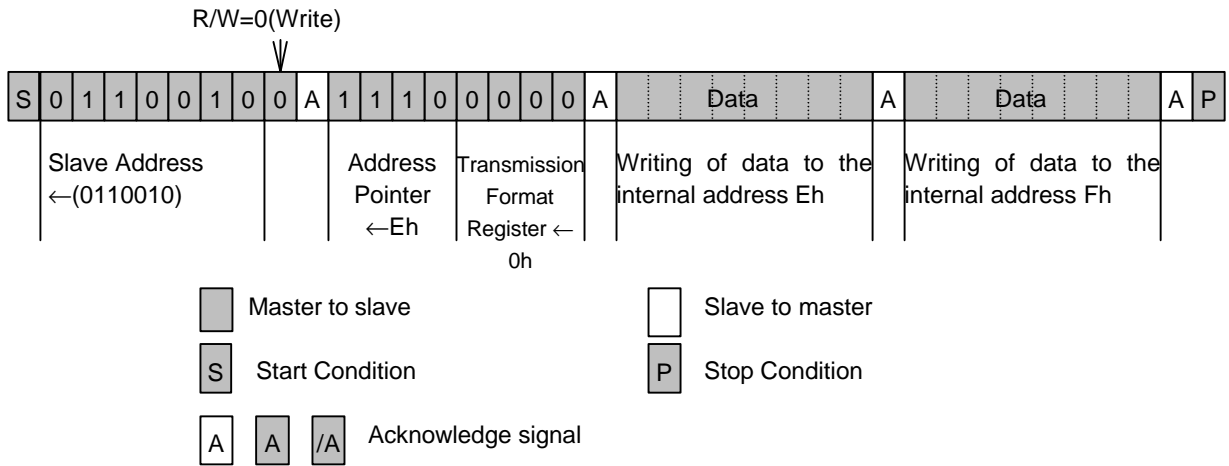

14.1.4. Data transmission read format of the RV5C387A

The RV5C387A allows the following three readout method of data an internal register.

- 1) The first method to reading data from the internal register is to specify an internal address by setting the internal address pointer and the transmission format register described 14.1.3, generate the Repeated Start Condition (See section 14.1.2-(3)) to change the data transmission direction to perform reading. The internal address pointer is set to Fh when the Stop Condition is met. Therefore, this method of reading allows no insertion of Stop Condition before the Repeated Start Condition. Set 0h to the Transmission Format Register when this method used.

Example 1 of Data Read (when data is read from 2h to 4h)

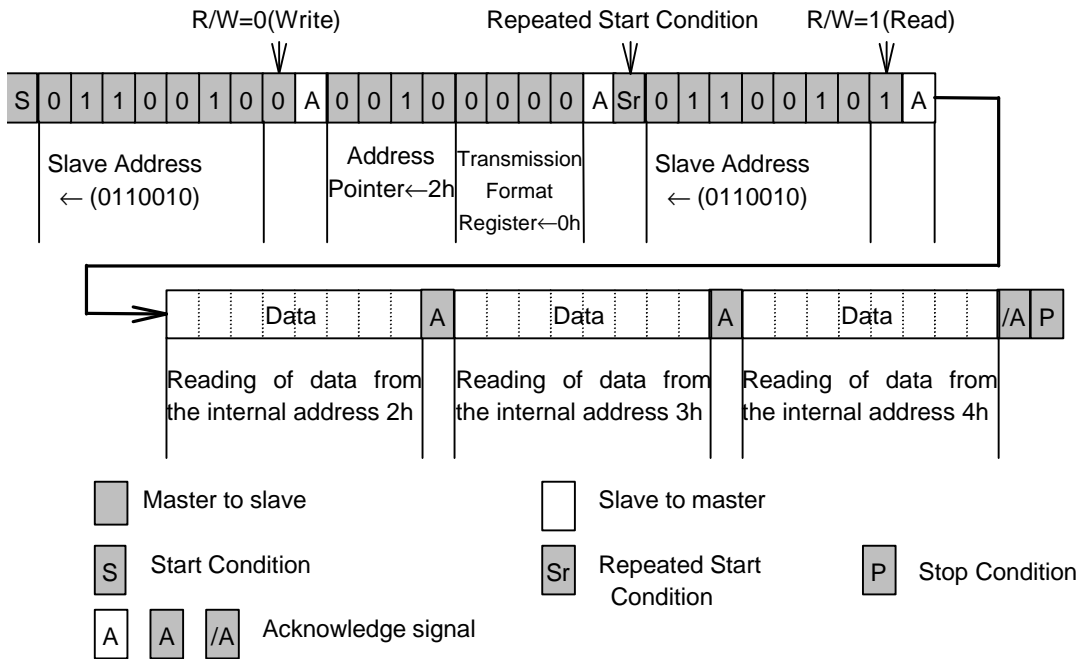

- 2) The second method to reading data from the internal register is to start reading immediately after writing to the Internal Address Pointer and the Transmission Format Register. Although this method is not based on I<sup>2</sup>C-Bus standard in a strict sense it still effective to shorten read time to ease load to the master. Set 4h to the transmission format register when this method used.

Example 2 of data read (when data is read from internal addresses Eh to 1h)

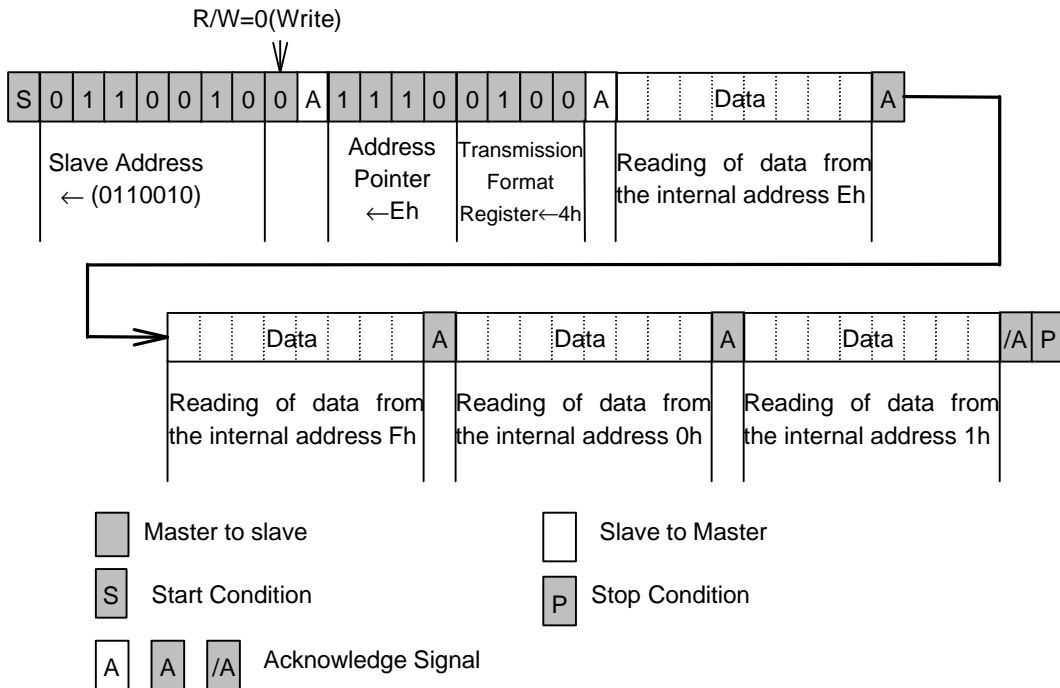

- 3) The third method to reading data from the internal register is to start reading immediately after writing to the Slave Address and R/W bit. Since the Internal Address Pointer is set to Fh by default as described in 1), this method is only effective when reading is started from the Internal Address Fh.

Example 3 of data read (when data is read from internal addresses Fh to 3h)

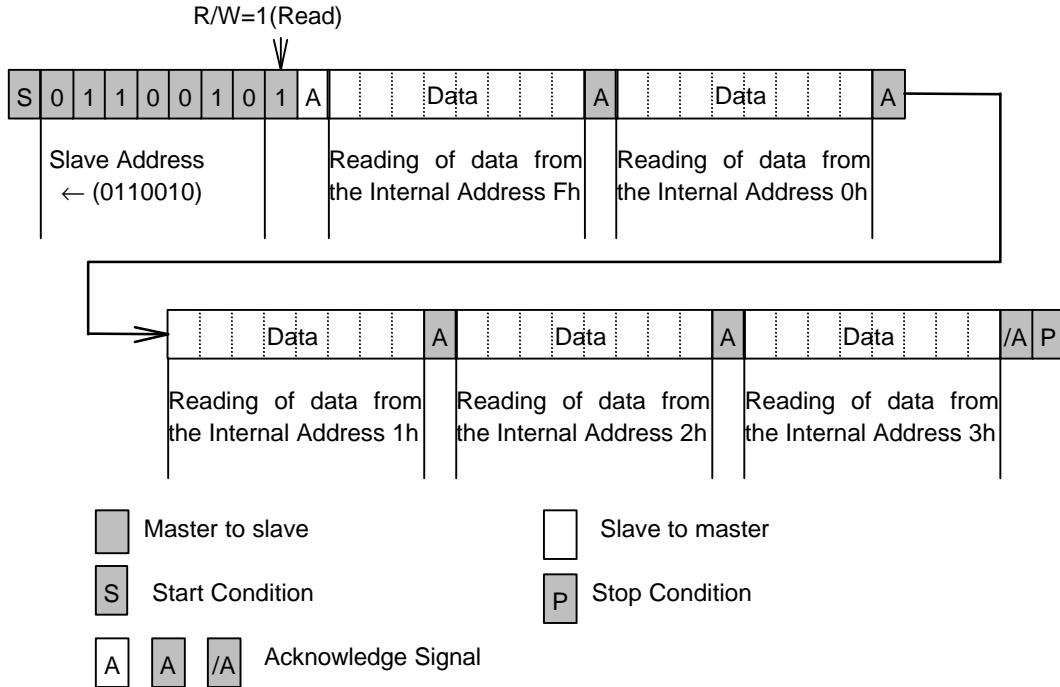



#### 14.1.5. Data Transmission under Special Condition

The RV5C387A holds the clock tentatively for duration from Start Condition to avoid invalid read or write clock on carrying clock. When clock carried during this period, which will be adjusted within approx. 61 $\mu$ s from Stop Condition. To prevent invalid read or write, clock shall be made during one transmission operation (from Start Condition to Stop Condition). When 0.5 to 1.0 second elapses after Start Condition, any access to the RV5C387A is automatically released to release tentative hold of the clock, and access from the CPU is forced to be terminated (The same action as made Stop Condition is received: automatic resume function from I<sup>2</sup>C-Bus interface). Therefore, one access must be complete within 0.5 seconds. The automatic resume function prevents delay in clock even if SCL is stopped from sudden failure of the system during clock read operation.

Also a second Start Condition after the first Start Condition and before the Stop Condition is regarded "Repeated Start Condition". Therefore, when 0.5 to 1.0 seconds passed after the first Start Condition, an access to the RV5C387A is automatically released.

If access is tried after automatic resume function is activated, no acknowledge signal will be output for writing while FFh will be output for reading.

The user shall always be able to access the real-time clock as long as three conditions are met.

- (1) No Stop Condition shall be generated until clock read/write is started and completed.
- (2) One cycle read/write operation shall be complete within 0.5 seconds.
- (3) Do not make Start Condition within 61 $\mu$ s from Stop Condition. When clock is carried during the access, which will be adjusted within approx. 61 $\mu$ s from Stop Condition.

Bad example of reading from seconds to hours (invalid read)

(Start Condition) → (Read of seconds) → (read of minutes) → (Stop Condition) → (Start Condition) → (Read of hour) → (Stop Condition)

Assuming read was started at 05:59:59 P.M. and while reading seconds and minutes the time advanced to 06:00:00 P.M. At this time second digit is hold so read the read as 05:59:59. Then the RV5C387A confirms (Stop Condition) and carries second digit being hold and the time change to 06:00:00 P.M. Then, when the hour digit is read, it changes to 6. The wrong results of 06:59:59 will be read.

## 14.2. Configuration of Oscillation Circuit and Correction of Time Count Deviations

## 14.2.1. Configuration of Oscillation Circuit

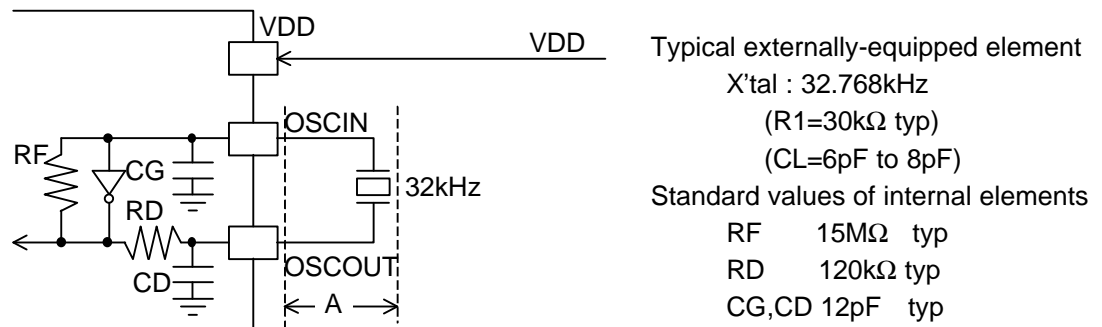

The oscillation circuit is driven at a constant voltage of approximately 1.2 volts relative to the level of the VSS pin input. As such, it is configured to generate an oscillating waveform with a peak-to-peak voltage on the order of 1.2 volts on the positive side of the VSS pin input.

## &lt; Considerations in Handling Crystal Oscillators &gt;

Generally, crystal oscillators have basic characteristics including an equivalent series resistance (R1) indicating the ease of their oscillation and a load capacitance (CL) indicating the degree of their center frequency. Particularly, crystal oscillators intended for use in the RV5C387A are recommended to have a typical R1 value of 30kΩ and a typical CL value of 6 to 8pF. To confirm these recommended values, contact the manufacturers of crystal oscillators intended for use in these particular models.

## &lt; Considerations in Installing Components around the Oscillation Circuit &gt;

- 1) Install the crystal oscillator in the closest possible vicinity to the real-time clock ICs.
- 2) Avoid laying any signal lines or power lines in the vicinity of the oscillation circuit (particularly in the area marked "A" in the above figure).
- 3) Apply the highest possible insulation resistance between the OSCIN and OSCOUT pins and the printed circuit board.
- 4) Avoid using any long parallel lines to wire the OSCIN and OSCOUT pins.
- 5) Take extreme care not to cause condensation, which leads to various problems such as oscillation halt.

## &lt; Other Relevant Considerations &gt;

- 1) For external input of 32.768-kHz clock pulses to the OSCIN pin:
  - DC coupling: Prohibited due to an input level mismatch.
  - AC coupling: Permissible except that the oscillation halt sensing circuit does not guarantee perfect operation because it may cause sensing errors due to such factors as noise.
- 2) To maintain stable characteristics of the crystal oscillator, avoid driving any other IC through 32.768-kHz clock pulses output from the OSCOUT pin.

14.2.2. Measurement of Oscillation Frequency

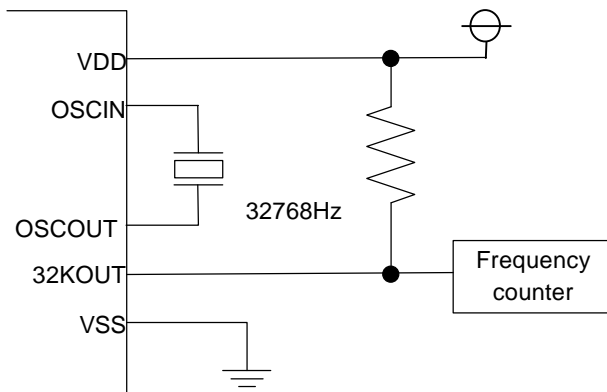

- \* 1) The RV5C387A is configured to generate 32.768-kHz clock pulses for output from the 32KOUT pin.
- \* 2) A frequency counter with 6 (more preferably 7) or more digits on the order of 1ppm is recommended for use in the measurement of the oscillation frequency of the oscillation circuit.
- \* 3) The 32KOUT pin should be connected to the VDD pin as a pull-up resistor.

14.2.3. Adjustment of Oscillation frequency

The oscillation frequency of the oscillation circuit can be adjusted by varying procedures depending on the usage of Model RV5C387A in the system into which they are to be built and on the allowable degree of time count errors. The flow chart below serves as a guide to selecting an optimum oscillation frequency adjustment procedure for the relevant system.

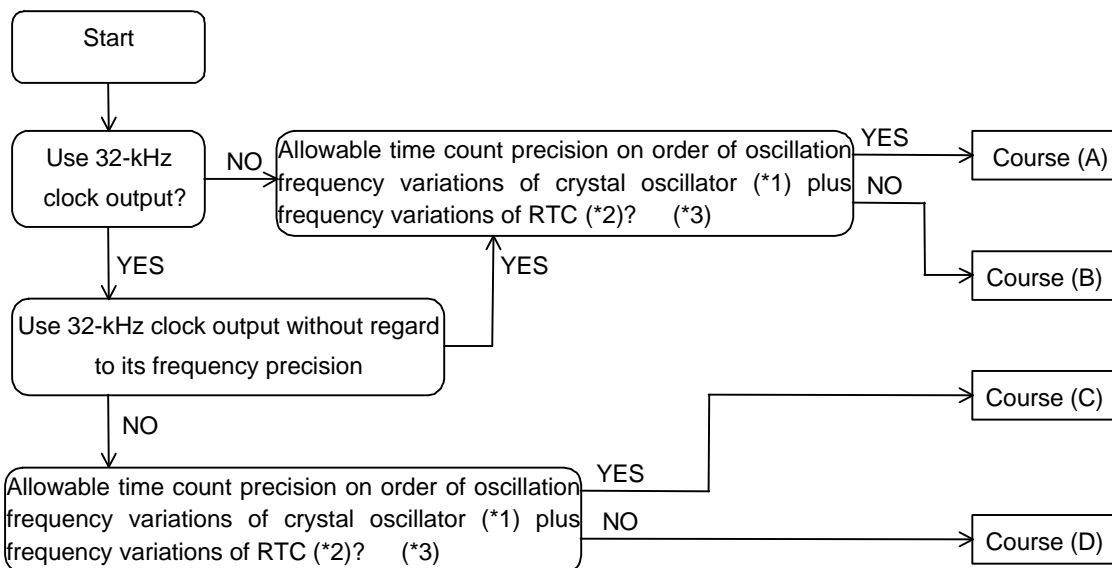

- \* 1) Generally, crystal oscillators for commercial use are classified in terms of their center frequency depending on their load capacitance (CL) and further divided into ranks on the order of  $\pm 10$ ,  $\pm 20$ , and  $\pm 50$ ppm depending on the degree of their oscillation frequency variations.
- \* 2) Basically, Model RV5C387A is configured to cause frequency variations on the order of  $\pm 5$  to  $\pm 10$ ppm at normal temperature.
- \* 3) Time count precision as referred to in the above flow chart is applicable to normal temperature and actually affected by the temperature characteristics and other properties of crystal oscillators.

## Course (A)

When the time count precision of each RTC is not to be adjusted, the crystal oscillator intended for use in that RTC may have any CL value requiring no presetting. The crystal oscillator may be subject to frequency variations which are selectable within the allowable range of time count precision. Several crystal oscillators and RTCs should be used to find the center frequency of the crystal oscillators by the method described in "14.2. 2. Measurement of Oscillation Frequency" and then calculate an appropriate oscillation adjustment value by the method described in "14.2. 4. Oscillation Adjustment Circuit" for writing this value to the RV5C387A.

## Course (B)

When the time count precision of each RTC is to be adjusted within the oscillation frequency variations of the crystal oscillator plus the frequency variations of the real-time clock ICs, it becomes necessary to correct deviations in the time count of each RTC by the method described in "14.2.4. Oscillation Adjustment Circuit". Such oscillation adjustment provides crystal oscillators with a wider range of allowable settings of their oscillation frequency variations and their CL values. The real-time clock IC and the crystal oscillator intended for use in that real-time clock IC should be used to find the center frequency of the crystal oscillator by the method described in "14.2.2. Measurement of Oscillation Frequency" and then confirm the center frequency thus found to fall within the range adjustable by the oscillation adjustment circuit before adjusting the oscillation frequency of the oscillation circuit. At normal temperature, the oscillation frequency of the oscillator circuit can be adjusted by up to approximately  $\pm 1.5$ ppm.

## Course (C)

Course (C) together with Course (D) requires adjusting the time count precision of each RTC as well as the frequency of 32.768-kHz clock pulses output from the 32KOUT pin. Normally, the oscillation frequency of the crystal oscillator intended for use in the RTCs should be adjusted by adjusting the oscillation stabilizing capacitors CG and CD connected to both ends of the crystal oscillator. The RV5C387A, which incorporate the CG and the CD, require adjusting the oscillation frequency of the crystal oscillator through its CL value. Generally, the relationship between the CL value and the CG and CD values can be represented by the following equation:

$CL = (CG \times CD) / (CG + CD) + CS$  where "CS" represents the floating capacity of the printed circuit board.

The crystal oscillator intended for use in the RV5C387A is recommended to have the CL value on the order of 6 to 8pF. Its oscillation frequency should be measured by the method described in "14.2.2. Measurement of Oscillation Frequency". Any crystal oscillator found to have an excessively high or low oscillation frequency (causing a time count gain or loss, respectively) should be replaced with another one having a smaller and greater CL value, respectively until another one having an optimum CL value is selected. In this case, the bit settings disabling the oscillation adjustment circuit (see "14.2.4. Oscillation Adjustment Circuit") should be written to the oscillation adjustment register.

Incidentally, the high oscillation frequency of the crystal oscillator can also be adjusted by adding an external oscillation stabilization capacitor CGOUT as illustrated in the diagram below.

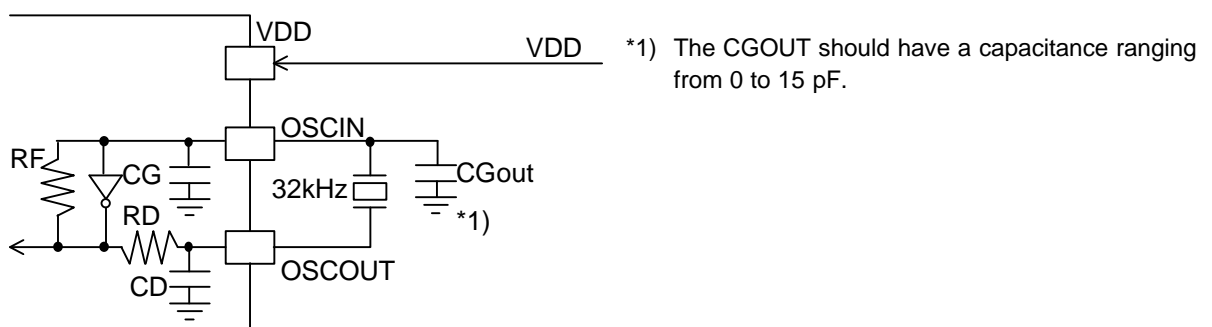

## Course (D)

It is necessary to select the crystal oscillator in the same manner as in Course (C) as well as correct errors in the time count of each RTC in the same manner as in Course (B) by the method described in "14.2.4. Oscillation Adjustment Circuit".

## 14.2.4. Oscillation Adjustment Circuit

The oscillation adjustment circuit can be used to correct a time count gain or loss with high precision by varying the number of 1-second clock pulses once per 20 seconds. When such oscillation adjustment is not to be made, the oscillation adjustment circuit can be disabled by writing the settings of "\*", 0, 0, 0, 0, 0, "\*" ("\*" representing "0" or "1") to the F6, F5, F4, F3, F2, F1, and F0 bits in the oscillation adjustment circuit. Conversely, when such oscillation adjustment is to be made, an appropriate oscillation adjustment value can be calculated by the equation below for writing to the oscillation adjustment circuit.

## (1) When Oscillation Frequency (\* 1) Is Higher Than Target Frequency (\* 2) (Causing Time Count Gain)

Oscillation adjustment value (\*3) =  $\frac{\text{Oscillation frequency} - \text{Target Frequency} + 0.1}{\text{Oscillation frequency} \times 3.051 \times 10^{-6}}$

$$\approx (\text{Oscillation Frequency} - \text{Target Frequency}) \times 10 + 1$$

## \* 1) Oscillation frequency:

Frequency of clock pulse output from the 32KOUT pin at normal temperature in the manner described in "14.2.2. Measurement of Oscillation Frequency".

## \* 2) Target frequency:

Desired frequency to be set. Generally, a 32.768-kHz crystal oscillator has such temperature characteristics as to have the highest oscillation frequency at normal temperature. Consequently, the crystal oscillator is recommended to have target frequency settings on the order of 32.768 to 32.76810 kHz (+3.05ppm relative to 32.768 kHz). Note that the target frequency differs depending on the environment or location where the equipment incorporating the RTC is expected to be operated.

## \* 3) Oscillation adjustment value:

Value that is to be finally written to the F0 to F6 bits in the Oscillation Adjustment Register and is represented in 7-bit coded decimal notation.

## (2) When Oscillation Frequency Is Equal To Target Frequency (Causing Time Count neither Gain nor Loss)

Oscillation adjustment value = 0, +1, -64, or -63

## (3) When Oscillation Frequency Is Lower Than Target Frequency (Causing Time Count Loss)

Oscillation adjustment value =  $\frac{\text{Oscillation frequency} - \text{Target Frequency}}{\text{Oscillation frequency} \times 3.051 \times 10^{-6}}$

$$\approx (\text{Oscillation Frequency} - \text{Target Frequency}) \times 10$$

Oscillation adjustment value calculations are exemplified below

## (A) For an oscillation frequency = 32768.85Hz and a target frequency = 32768.05Hz

$$\begin{aligned} \text{Oscillation adjustment value} &= (32768.85 - 32768.05 + 0.1) / (32768.85 \times 3.051 \times 10^{-6}) \\ &\approx (32768.85 - 32768.05) \times 10 + 1 \\ &= 9.001 \approx 9 \end{aligned}$$

In this instance, write the settings (F6,F5,F4,F3,F2,F1,F0)=(0,0,0,1,0,0,1) in the oscillation adjustment register. Thus, an appropriate oscillation adjustment value in the presence of any time count gain represents a distance from 01h.

## (B) For an oscillation frequency = 32763.95Hz and a target frequency = 32768.05Hz

$$\begin{aligned} \text{Oscillation adjustment value} &= (32763.95 - 32768.05) / (32763.95 \times 3.051 \times 10^{-6}) \\ &\approx (32763.95 - 32768.05) \times 10 \\ &= -41.015 \approx -41 \end{aligned}$$

To represent an oscillation adjustment value of -41 in 7-bit coded decimal notation, subtract 41 (29h) from 128 (80h) to obtain 57h. In this instance, write the settings of (F6,F5,F4,F3,F2,F1,F0) = (1,0,1,0,1,1,1) in the oscillation adjustment register. Thus, an appropriate oscillation adjustment value in the presence of any time count loss represents a distance from 80h.

Oscillation adjustment involves an adjustment differential of approximately  $\pm 1.5$ ppm from the target frequency at normal temperature.

Notes:

- 1) Oscillation adjustment does not affect the frequency of 32.768-kHz clock pulses output from the 32KOUT pin.
- 2) Oscillation adjustment value range: When the oscillation frequency is higher than the target frequency (causing a time count gain), an appropriate time count gain ranges from -3.05ppm to -189.2ppm with the settings of "0, 0, 0, 0, 0, 1, 0" to "0, 1, 1, 1, 1, 1, 1" written to the F6, F5, F4, F3, F2, F1, and F0 bits in the oscillation adjustment register, thus allowing correction of a time count gain of up to +189.2ppm. Conversely, when the oscillation frequency is lower than the target frequency (causing a time count loss), an appropriate time count gain ranges from +3.05ppm to +189.2ppm with the settings of "1, 1, 1, 1, 1, 1, 1" to "1, 0, 0, 0, 0, 1, 0" written to the F6, F5, F4, F3, F2, F1, and F0 bits in the oscillation adjustment register, thus allowing correction of a time count loss of up to -189.2ppm.

14.3. Oscillation Halt Sensing and Supply Voltage Monitoring

The oscillation halt sensing circuit is configured to record a halt on oscillation by 32.768-kHz clock pulses. The supply voltage monitoring circuit is configured to record a drop in supply voltage below a threshold voltage of 2.1 or 1.6v. Both the flag bits of these circuits (i.e. the XSTP bit for the former and the VDET bit for the latter) in the control register 2, are maintained "1" until they are reset by the setting of 0 in the same bits.

When the XSTP bit is set to 1 for the oscillation halt sensing circuit, the VDET bit is reset to 0 for the supply voltage monitoring circuit. The relationship between the XSTP and VDET bits is shown in the table below.

XSTP	VDET	Conditions of supply voltage and oscillation
0	0	No drop in supply voltage below threshold voltage and no halt in oscillation
0	1	Drop in supply voltage below threshold voltage and no halt in oscillation
1	*	Halt on oscillation

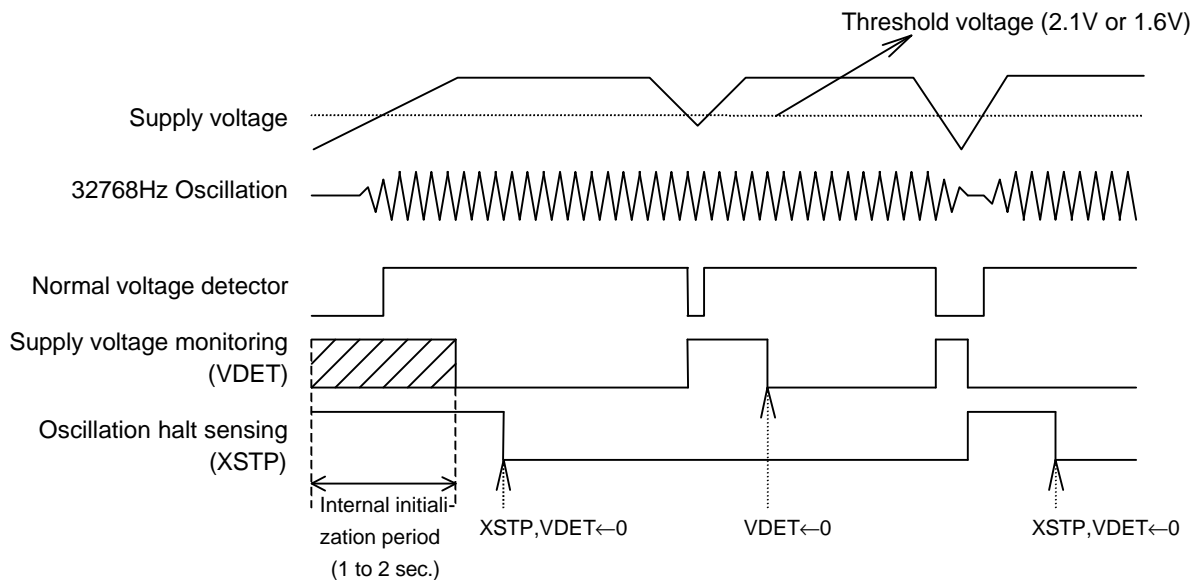

When the XSTP bit is set to 1 in the control register 2, the F6 to F0, WALE, DALE, /12·24, /CLEN2, TEST, CT2, CT1, CT0, VDSL, VDET, SCRATCH, /CLEN1, CTFG, WAFG, and DAFG bits are reset to 0 in the oscillation adjustment register, the control register 1, and the control register 2. The XSTP bit is also set to 1 at power-on from 0 volts. Note that the XSTP bit may be locked upon instantaneous power-down.

< Considerations in Using Oscillation Halt Sensing Circuit >

Be sure to prevent the oscillation halt sensing circuit from malfunctioning by preventing the following:

- 1) Instantaneous power-down on the VDD
- 2) Condensation on the crystal oscillator
- 3) On-board noise to the crystal oscillator
- 4) Applying to individual pins voltage exceeding their respective maximum ratings

In particular, note that the XSTP bit may fail to be set to 1 in the presence of any applied supply voltage as illustrated below in such events as backup battery installation. Further, give special considerations to prevent excessive chattering in the oscillation halt sensing circuit.



< Supply Voltage Sensing Circuit >

The Supply voltage monitoring circuit is configured to conduct a sampling operation during an interval of 7.8ms per second to check for a drop in supply voltage below a threshold voltage of 2.1 or 1.6v for the VDSL bit setting of 0 (the default setting) or 1, respectively, in the Control Register 2, thus minimizing supply current requirements as illustrated in the timing chart below. This circuit suspends a sampling operation once the VDET bit is set to 1 in the Control Register 2.

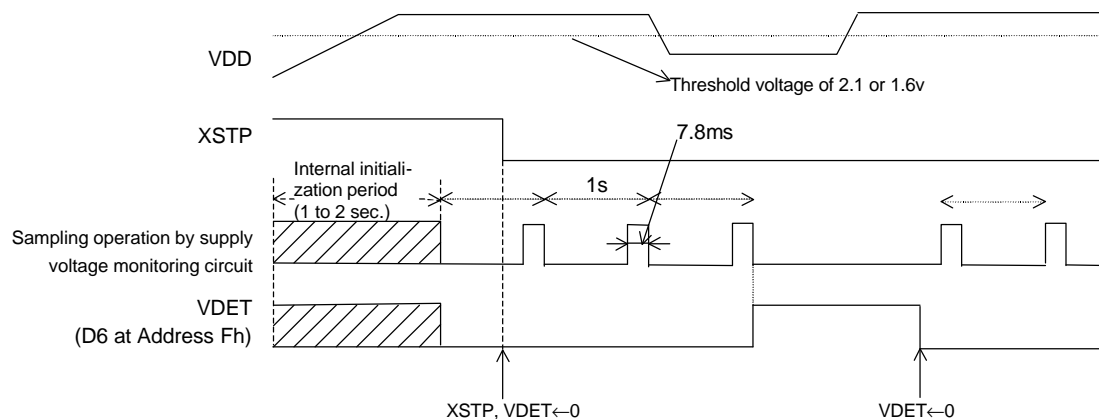

14.4. Alarm and Periodic Interrupt

The RV5C387A incorporates the alarm interrupt circuit and the periodic interrupt circuit that are configured to generate alarm signals and periodic interrupt signals, respectively, for output from the /INTRA, /INTRB, or /INTRC pins as described below.

(1) Alarm Interrupt Circuit

The alarm interrupt circuit is configured to generate alarm signals for output from the /INTRB or /INTRC, which is driven low (enabled) upon the occurrence of a match between current time read by the time counters (the day-of-week, hour, and minute counters) and alarm time preset by the alarm registers (the Alarm\_W registers intended for the day-of-week, hour, and minute digit settings and the Alarm\_D registers intended for the hour and minute digit settings). The Alarm\_W is output from the /INTRB, and the Alarm\_D is output from /INTRC.

(2) Periodic Interrupt Circuit

The periodic interrupt circuit is configured to generate either clock pulses in the pulse mode or interrupt signals in the level mode for output from the /INTRC pin depending on the CT2, CT1, and CT0 bit settings in the control register 1.

The above two types of interrupt signals are monitored by the flag bits (i.e. the WAFG, DAFG, and CTFG bits in the Control Register 2) and enabled or disabled by the enable bits (i.e. the WALE, DALE, CT2, CT1, and CT0 bits in the Control Register 1) as listed in the table below.

	Flag bits	Enable bits	Output Pin
Alarm_W	WAFG (D1 at Address Fh)	WALE (D7 at Address Eh)	/INTRB
Alarm_D	DAFG (D0 at Address Fh)	DALE (D6 at Address Eh)	/INTRC
Peridic Interrupt	CTFG (D2 at Address Fh)	CT2=CT1=CT0=0 (These bit setting of "0" disable the Periodic Interrupt) (D2 to D0 at Address Eh)	/INTRA

\* At power-on, when the WALE, DALE, CT2, CT1, and CT0 bits are set to 0 in the Control Register 1, the /INTRA, /INTRB, and /INTRC pins are driven high (disabled).

14.4.1. Alarm Interrupt

The alarm interrupt circuit is controlled by the enable bits (i.e. the WALE and DALE bits in the Control Register 1) and the flag bits (i.e. the WAFG and DAFG bits in the Control Register 2). The enable bits can be used to enable this circuit when set to 1 and to disable it when set to 0. When intended for reading, the flag bits can be used to monitor alarm interrupt signals. When intended for writing, the flag bits will cause no event when set to 1 and will drive high (disable) the alarm interrupt circuit when set to 0.

The enable bits will not be affected even when the flag bits are set to 0. In this event, therefore, the alarm interrupt circuit will continue to function until it is driven low (enabled) upon the next occurrence of a match between current time and preset alarm time.

The alarm function can be set by presetting desired alarm time in the alarm registers (the Alarm\_W Registers for the day-of-week digit settings and both the Alarm\_W Registers and the Alarm\_D Registers for the hour and minute digit settings) with the WALE and DALE bits once set to 0 and then to 1 in the Control Register 1. Note that the WALE and DALE bits should be once set to 0 in order to disable the alarm interrupt circuit upon the coincidental occurrence of a match between current time and preset alarm time in the process of setting the alarm function.

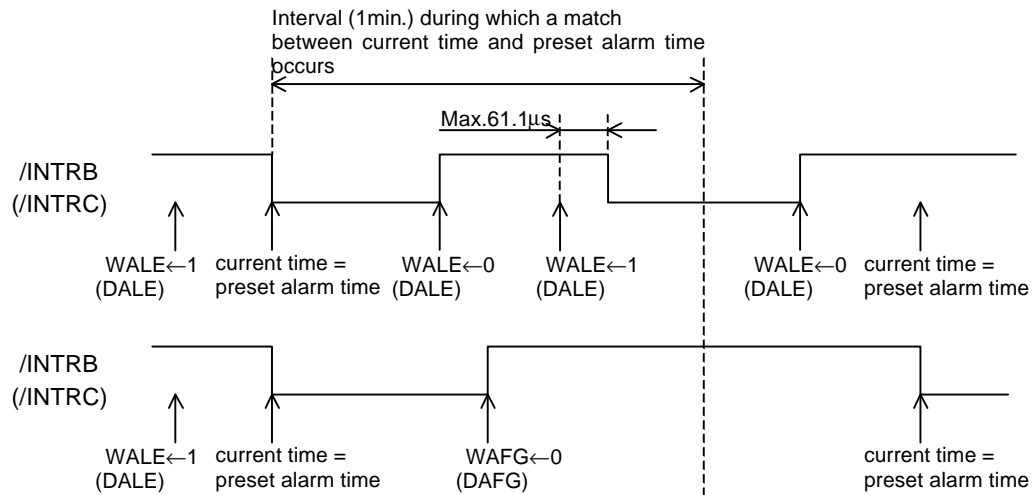



14.4.2. Periodic Interrupt

Setting of the periodic selection bits (CT2 to CT0) enables periodic interrupt to the CPU. There are two waveform modes: pulse mode and level mode. In the pulse mode, the output has a waveform duty cycle of around 50%. In the level mode, the output is cyclically driven low and, when the CTFG bit is set to 0, the output is return to High (OFF).

CT2	CT1	CT0	Description		
			Wave form mode	Interrupt Cycle and Falling Timing	
0	0	0	-	OFF(H)	(Default)
0	0	1	-	Fixed at "L"	
0	1	0	Pulse Mode *1)	2Hz(Duty50%)	
0	1	1	Pulse Mode *1)	1Hz(Duty50%)	
1	0	0	Level Mode *2)	Once per 1 second (Synchronized with Second counter increment)	
1	0	1	Level Mode *2)	Once per 1 minute (at 00 seconds of every Minute)	
1	1	0	Level Mode *2)	Once per hour (at 00 minutes and 00 Seconds of every hour)	
1	1	1	Level Mode *2)	Once per month (at 00 hours, 00 minutes, and 00 seconds of first day of every month)	

\*1) Pulse Mode: 2-Hz and 1-Hz clock pulses are output in synchronization with the increment of the second counter as illustrated in the timing chart below.

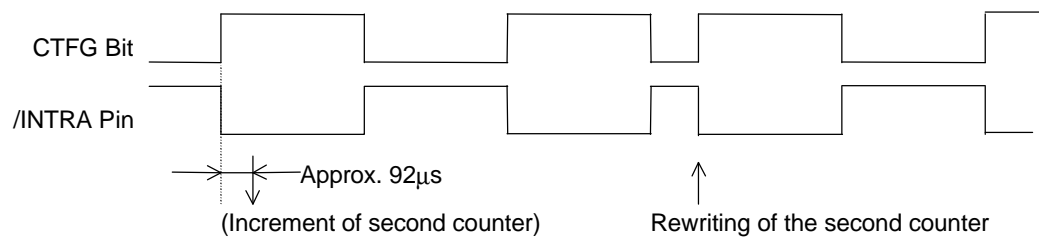

In the pulse mode, the increment of the second counter is delayed by approximately 92 µs from the falling edge of clock pulses. Consequently, time readings immediately after the falling edge of clock pulses may appear to lag behind the time counts of the real-time clocks by approximately 1 second. Rewriting the second counter will reset the other time counters of less than 1 second, driving the /INTRA pin low.

\*2) Level Mode: Periodic interrupt signals are output with selectable interrupt cycle settings of 1 second, 1 minute, 1 hour, and 1 month. The increment of the second counter is synchronized with the falling edge of periodic interrupt signals. For example, periodic interrupt signals with an interrupt cycle setting of 1 second are output in synchronization with the increment of the second counter as illustrated in the timing chart below.

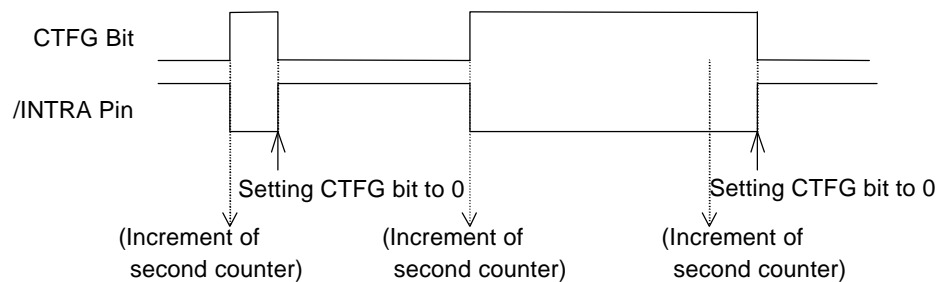

\*1), \*2) When the oscillation adjustment circuit is used, the interrupt cycle will fluctuate once per 20sec. as follows:  
 Pulse Mode: The "L" period of output pulses will increment or decrement by a maximum of ±3.784ms. For example, 1-Hz clock pulses will have a duty cycle of 50 ±0.3784%.  
 Level Mode: A periodic interrupt cycle of 1 second will increment or decrement by a maximum of ±3.784 ms.

## 14.5. 32-kHz CLOCK OUTPUT

For the RV5C387A, 32.768-kHz clock pulses are output from the 32KOUT pin when either the /CLEN1 bit in the Control Register 2 or the /CLEN2 bit in the Control Register 1 is set to 0. When both the /CLEN1 and /CLEN2 bits are set to 0, the 32KOUT pin output is driven high (off). For the RV5C387A, 32.768-kHz clock pulses are output from the 32KOUT pin regardless of such internal register settings.

/CLEN1 (D3 at Address Fh)	/CLEN2 (D4 at Address Eh)	32KOUT PIN (Nch Open Drain)
1	1	OFF(H)
0(Default)	*	Clock pulses
*	0(Default)	

For the RV5C387A, the 32KOUT pin output is synchronized with the /CLEN1 and /CLEN2 bit settings as illustrated in the timing chart below.

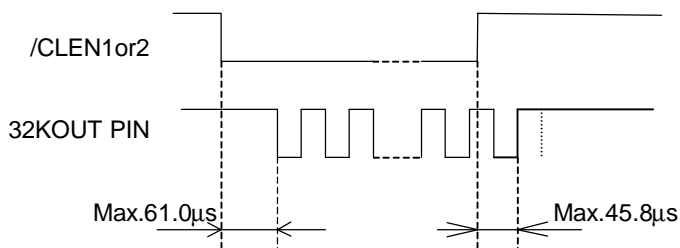

14.6. Typical Applications

14.6.1. Typical Power Circuit Configurations

Sample circuit configuration 1

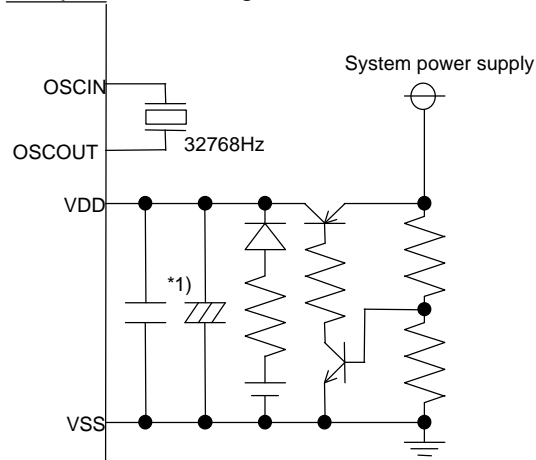

\*1) Install bypass capacitors for high-frequency and low-frequency applications in parallel in close vicinity to the RV5C387A.

Sample circuit configuration 2

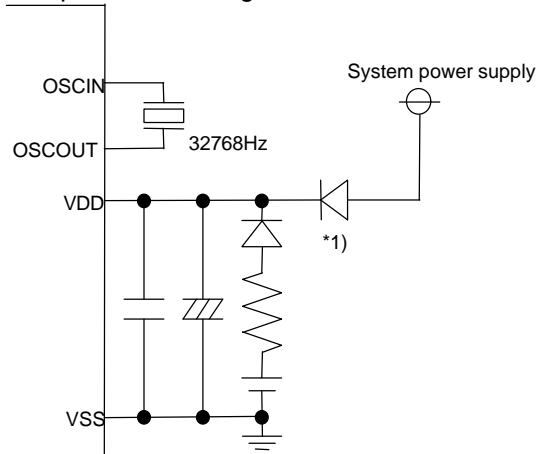

14.6.2. Connection of /INTRA, /INTRB, and /INTRC Pin

The /INTRA, /INTRB, and /INTRC pins follow the N-channel open drain output logic and contains no protective diode on the power supply side. As such, it can be connected to a pull-up resistor of up to 5.5 volts regardless of supply voltage.

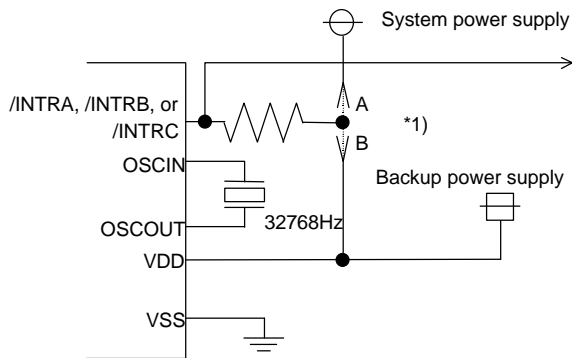

- \*1) Depending on whether the /INTRA, /INTRB, and /INTRC pins are to be used during battery backup, it should be connected to a pull-up resistor at the following different positions:
- (1) Position A in the left diagram when it is not to be used during battery backup.
  - (2) Position B in the left diagram when it is to be used during battery backup.

14.6.3. Connection of 32KOUT Pin

The 32KOUT pin follows the Nch. open drain output and contains no protective diode on the power supply side. As such, it can be connected to a device with a supply voltage of up to 5.5 volts regardless of supply voltage, provided that such connection involves considerations for the supply current requirements of a pull-up resistor, which can be roughly calculated by the following equation:

$$I = 0.5 \times (VDD \text{ or } VCC) / R_p$$

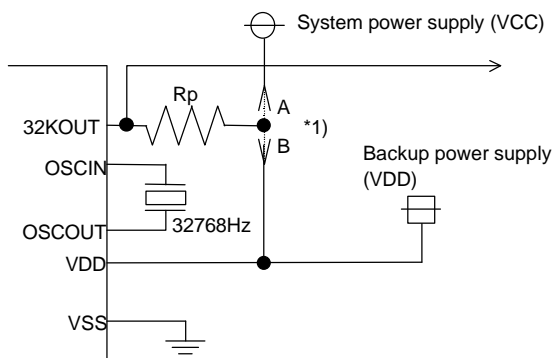

- \*1) Depending on whether the 32KOUT pin is to be used during battery backup, it should be connected to a pull-up resistor at the following different positions:
- (1) Position A in the left diagram when it is not to be used during battery backup.
  - (2) Position B in the left diagram when it is to be used during battery backup.

14.7. Typical Characteristics

Test Circuit

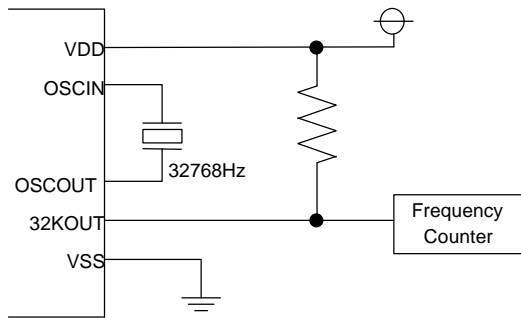

X'tal: 32.768kHz  
 (R1=30kΩ typ)  
 (CL=6pF to 8pF)  
 T<sub>opt</sub>: 25°C  
 Output: Open

Timekeeping Current vs. Supply voltage  
 (with no 32-kHz clock output)  
 (SCL,SDA="H", Output=Open, T<sub>opt</sub>=25°C)

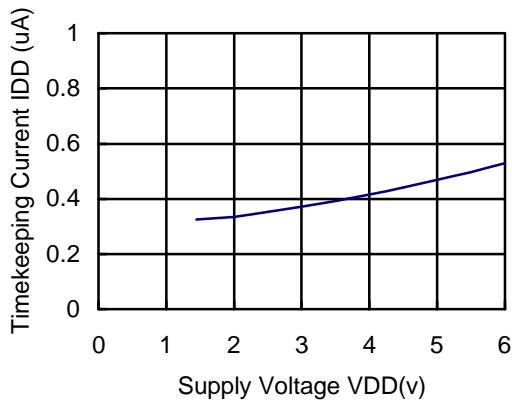

Timekeeping Current vs. Supply voltage  
 (with 32-kHz clock output)  
 (SCL,SDA="H", Output=Open, T<sub>opt</sub>=25°C)

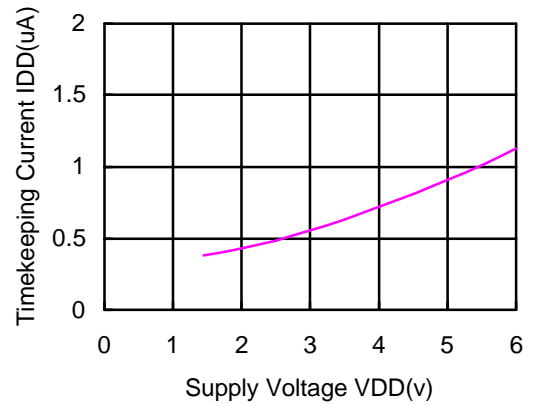

CPU Access Current vs. SCL Clock Frequency  
 (Output=Open, T<sub>opt</sub>=25°C)

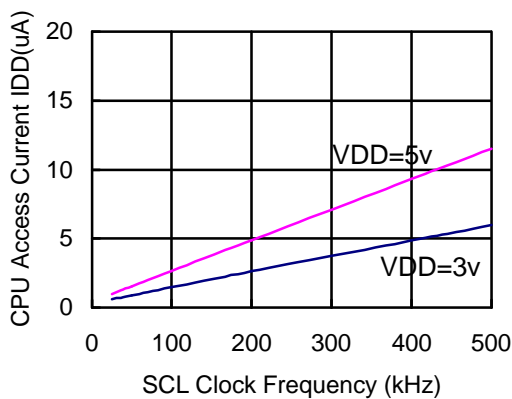

Timekeeping Current vs. Operating Temperature  
 (with no 32-kHz clock output)  
 (SCL,SDA=Open, Output=Open, )

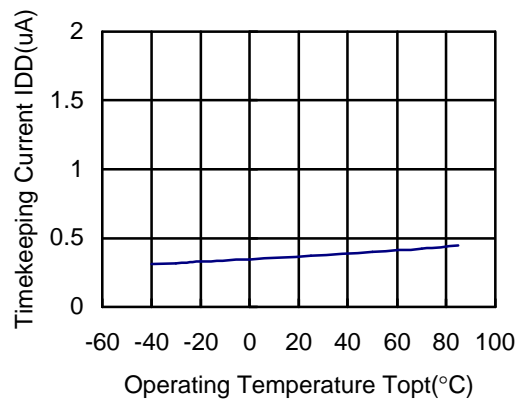

Oscillation Frequency Deviation vs. External CG  
(VDD=3v, T<sub>opt</sub>=25°C,  
External CG=0pF as standard)

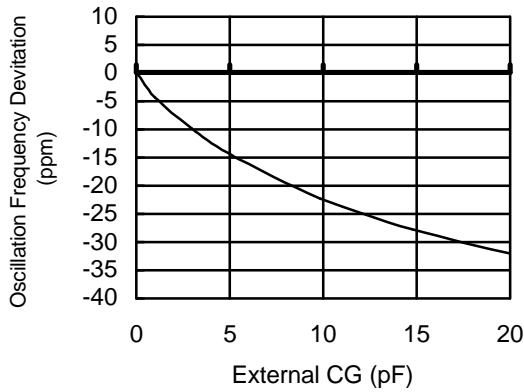

Oscillation Frequency Deviation vs. Supply Voltage  
(T<sub>opt</sub>=25°C, VDD=3v as standard)

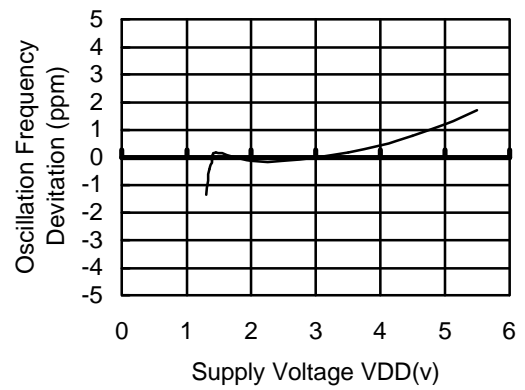

Oscillation Frequency Deviation vs. Operating Temperature  
(VDD=3v, T<sub>opt</sub>=25°C standard)

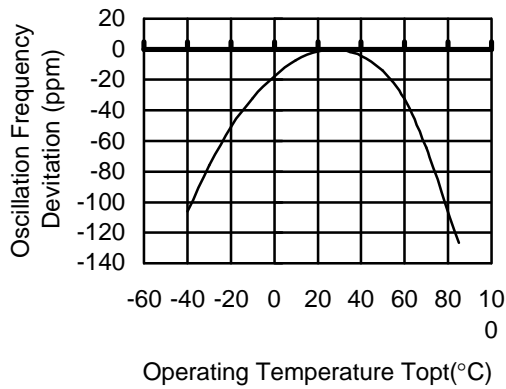

Oscillation Start Time vs. Supply Voltage  
(T<sub>opt</sub>=25°C)

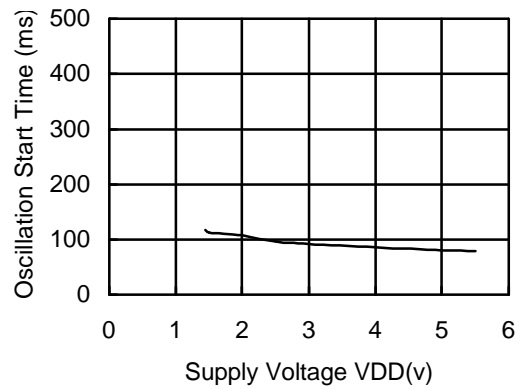

VOL vs. IOL  
(SDA, /INTRA, /INTRB, and /INTRC Pin)  
(T<sub>opt</sub>=25°C)

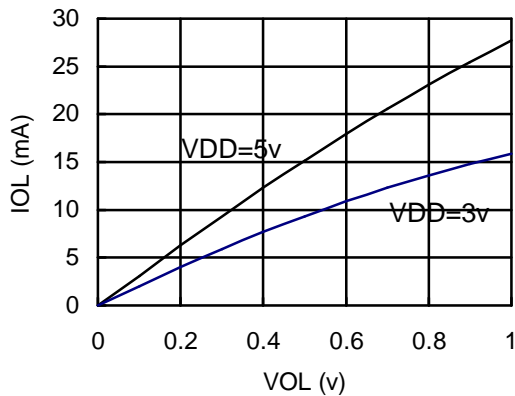

VOL vs. IOL  
(32KOUT Pin)  
(T<sub>opt</sub>=25°C)

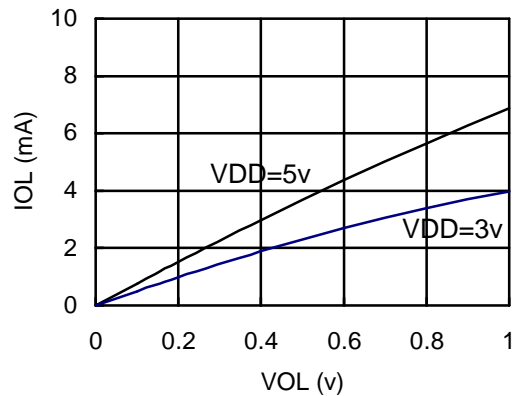

14.8. Typical Software-based Operations

14.8.1. Initialization at Power-on

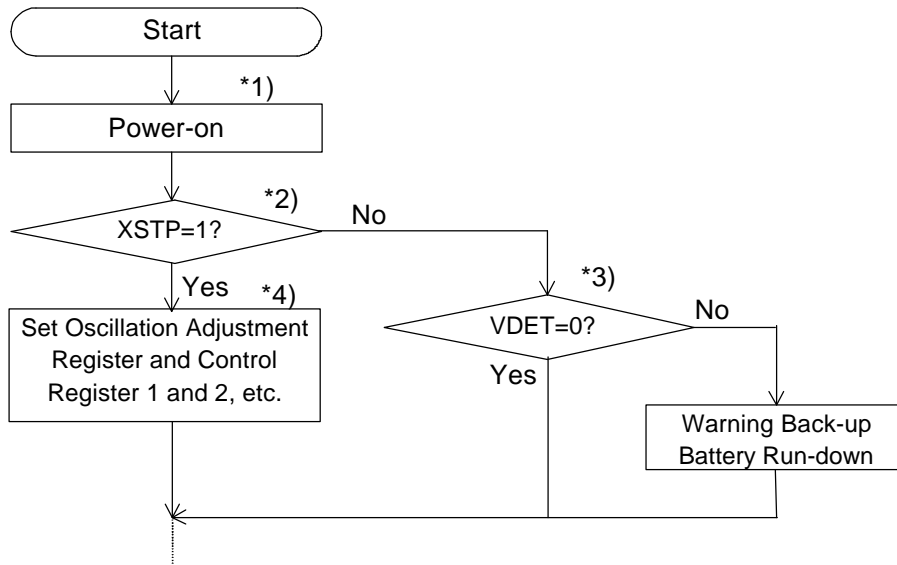

- \*1) After power-on from 0 volt, the start of oscillation and the process of internal initialization require a time span on the order of 1 to 2sec, so that access should be done after the lapse of this time span or more.
- \*2) The XSTP bit setting of 0 in the Control Register 1 indicates power-on from backup battery and not from 0v. The XSTP bit may fail to be set to 1 in the presence of any excessive chattering in power supply in such events as installing backup battery. Should there be any possibility of this failure occurring, it is recommended to initialize Model RV5C387A RTCs regardless of the current XSTP bit setting. For further details, see "14.3. Oscillation Halt Sensing and Supply Voltage Monitoring".
- \*3) This step is not required when the supply voltage monitoring circuit is not used.
- \*4) This step involves ordinary initialization including the Oscillation Adjustment Register and interrupt cycle settings, etc.

14.8.2. Writing of Time and Calendar Data

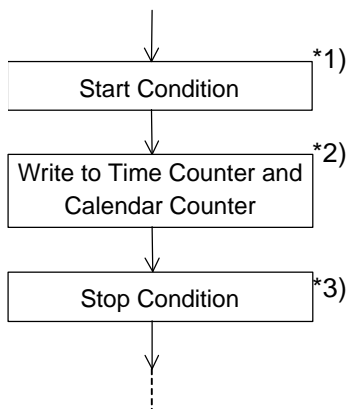

- \*1) When writing to clock and calendar counters, do not insert Stop Condition until all times from second to year have been written to prevent error in writing time. (Detailed in "14.1.5. Data Transmission under Special Condition".
- \*2) Any writing to the second counter will reset divider units lower than the second digits.
- \*3) Take care so that process from Start Condition to Stop Condition will be complete within 0.5sec. (Detailed in "14.1.5. Data Transmission under Special Condition".

The RV5C387A may also be initialized not at power-on but in the process of writing time and calendar data.

14.8.3. Reading Time and Calendar Data

(1) Ordinary Process of Reading Time and Calendar Data

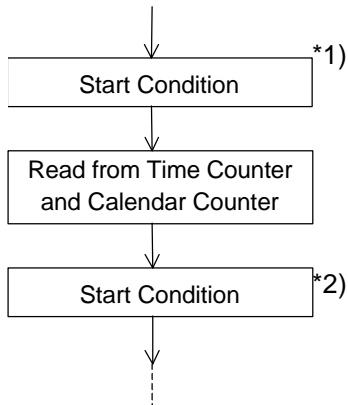

- \*1) When writing to clock and calendar counters, do not insert Stop Condition until all times from second to year have been written to prevent error in writing time. (Detailed in "14.1.5. Data Transmission under Special Condition".
- \*2) Take care so that process from Start Condition to Stop Condition will be complete within 0.5sec. (Detailed in "14.1.5. Data Transmission under Special Condition".

(2) Basic Process of Reading Time and Calendar Data with Periodic Interrupt Function

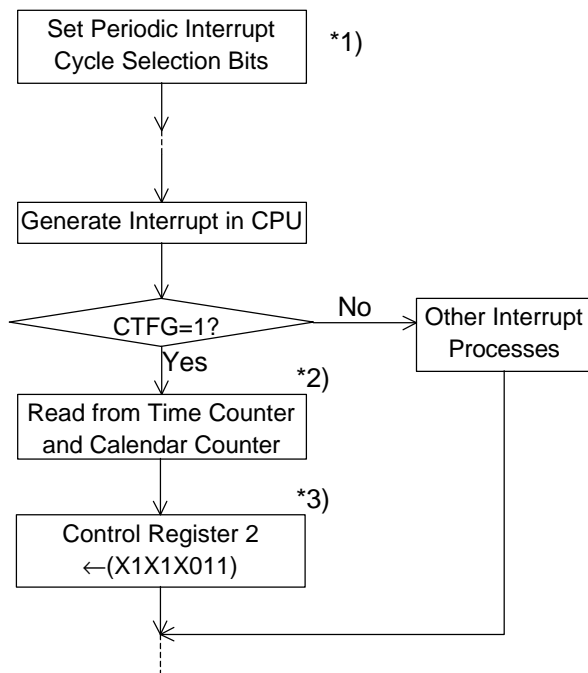

- \*1) This step is intended to select the level mode as a waveform mode for the periodic interrupt function.
- \*2) This step must be completed within 0.5 second.
- \*3) This step is intended to set the CTFG bit to 0 in the Control Register 2 to cancel an interrupt to the CPU.



(3) Applied Process of Reading Time and Calendar Data with Periodic Interrupt Function

Time data need not be read from all the time counters when used for such ordinary purposes as time count indication. This applied process can be used to read time and calendar data with substantial reductions in the load involved in such reading.

For Time Indication in "Day-of-Month, Day-of-week, Hour, Minute, and Second" Format:

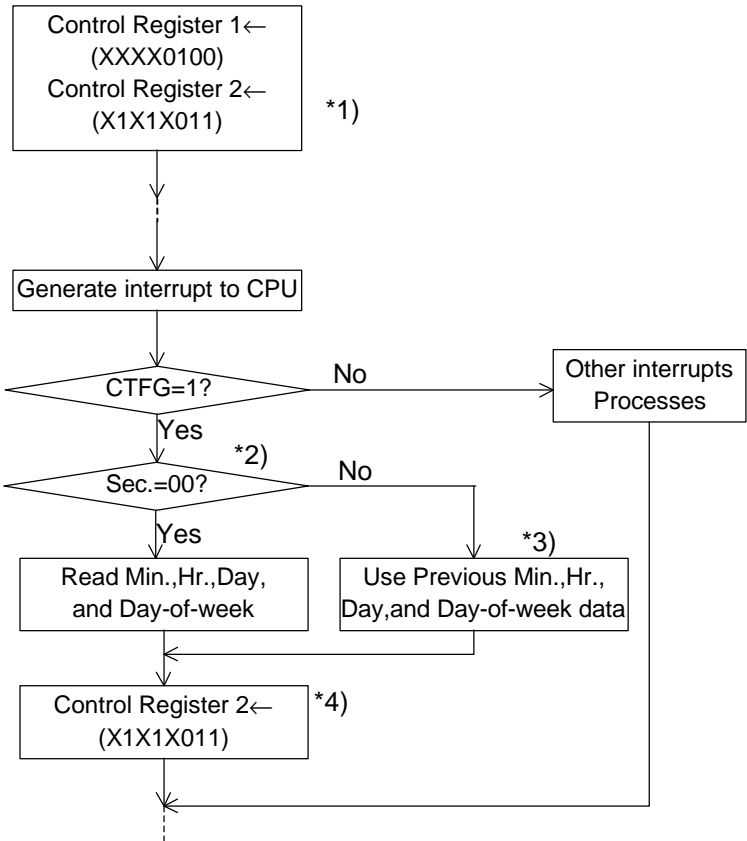

\*1) This step is intended to select the level mode as a waveform mode for the periodic interrupt function.

\*2) This step must be completed within 0.5 sec.

\*3) This step is intended to read time data from all the time counters only in the first session of reading time data after writing time data.

\*4) This step is intended to set the CTFG bit to 0 in the Control Register 2 to cancel an interrupt to the CPU.

14.8.4. Interrupt Process

(1) Periodic Interrupt

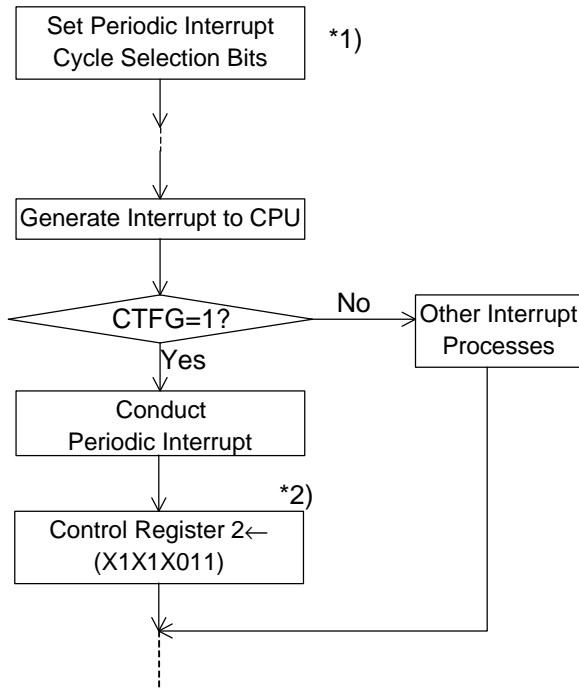

- \*1) This step is intended to select the level mode as a waveform mode for the periodic interrupt function.
- \*2) This step is intended to set the CTFG bit to 0 in the Control Register 2 to cancel an interrupt to the CPU.

(2) Alarm Interrupt

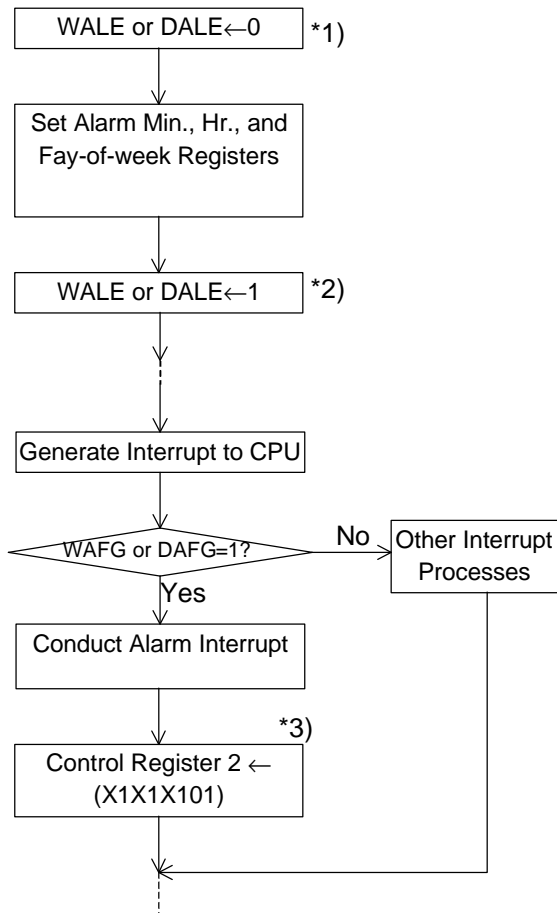

- \*1) This step is intended to once disable the alarm interrupt circuit by setting the WALE or DALE bits to 0 in anticipation of the coincidental occurrence of a match between current time and preset alarm time in the process of setting the alarm interrupt function.
- \*2) This step is intended to enable the alarm interrupt function after completion of all alarm interrupt settings.
- \*3) This step is intended to once cancel the alarm interrupt function by writing the settings of "X,1,X,1,X,1,0,1" and "X,1,X,1,X,1,1,0" to the Alarm\_W Registers and the Alarm\_D Registers, respectively.