

DATA SHEET

CHIP RESISTORS

RJ Series

1%; TC50

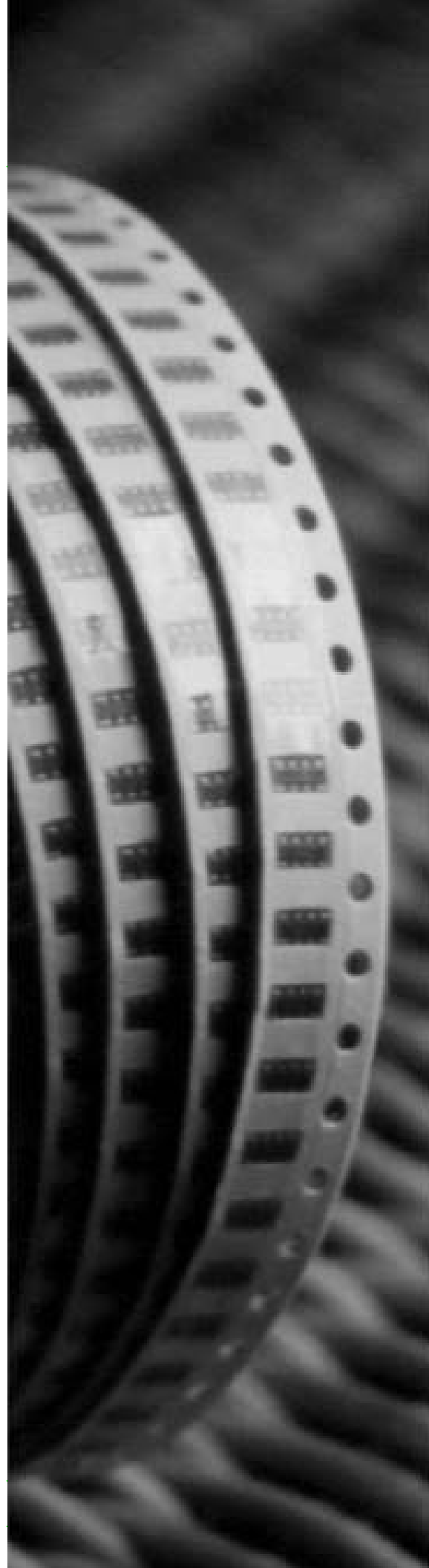

SCOPE

This specification describes RJ series chip resistors made by thin film process.

ORDERING INFORMATION

Part number is identified by the series, size, tolerance, packing style, temperature coefficient, special type and resistance value.

RJ XXXX X X E XX XXXX
(1) (2) (3) (4) (5)

(1) SIZE (INCH)

- 0201=0.024×0.012
- 0402=0.040×0.020
- 0603=0.063×0.033
- 0805=0.083×0.051
- 1206=0.122×0.063
- 1210=0.122×0.102
- 2010=0.197×0.098
- 2512=0.250×0.126

(2) TOLERANCE

F = ±1%

(3) PACKAGING TYPE

- R = Paper taping reel
- K = Embossed Plastic Tape Reel
- C = Bulk case

(4) SPECIAL TYPE

- 07 = 7 inch dia. Reel
- 10 = 10 inch dia. Reel
- 13 = 13 inch dia. Reel

(5) RESISTANCE VALUE:

5R6, 56R, 560R, 5K6, 56K, 1M.

MARKING

RJ0805 / RJ1206 / RJ1210 / RJ2010 / RJ2512



Fig. 1 Value=10KΩ

Either resistance in E-24 or E-96: 4 digits

First three digits for significant figure and 4th digit for number of zeros

RJ0603



Fig. 2 Value=12KΩ

E-24 series: 3 digits

First two digits for significant figure and 3rd digit for number of zeros



Fig. 3 Value=12.4KΩ

E-96 series: 3 digits for 0603±1% EIA-96 marking method. See Table I

RJ0201 / RJ0402



Fig. 4

No value marking

EIA - 96 MARKING RULE

Table I Shows the first two digits of the three-digit EIA-96 part-marking scheme.

Code	Value	Code	Value	Code	Value	Code	Value	Code	Value	Code	Value	Code	Value	Code	Value
01	100	13	133	25	178	37	237	49	316	61	422	73	562	85	750
02	102	14	137	26	182	38	243	50	324	62	432	74	576	86	768
03	105	15	140	27	187	39	249	51	332	63	442	75	590	87	787
04	107	16	143	28	191	40	255	52	340	64	453	76	604	88	806
05	110	17	147	29	196	41	261	53	348	65	464	77	619	89	825
06	113	18	150	30	200	42	267	54	357	66	475	78	634	90	845
07	115	19	154	31	205	43	274	55	365	67	487	79	649	91	866
08	118	20	158	32	210	44	280	56	374	68	499	80	665	92	887
09	121	21	162	33	215	45	287	57	383	69	511	81	681	93	909
10	124	22	165	34	221	46	294	58	392	70	523	82	698	94	931
11	127	23	169	35	226	47	301	59	402	71	536	83	715	95	953
12	130	24	174	36	232	48	309	60	412	72	549	84	732	96	976

The third character is a letter multiplier:

X=10⁻¹, Y=10⁻², A=10⁰, B=10¹, C=10², D=10³, E=10⁴, F=10⁵

CONSTRUCTION

The resistors are constructed out of a high-grade ceramic body. Internal metal electrodes are added at each end and connected by a resistive layer. The resistive layer is adjusted to give the approximate required resistance and laser cutting of this resistive layer that achieves tolerance trims the value. The resistive layer is covered with a protective coat and printed with the resistance value. Finally, the two external terminations are added. See fig.5

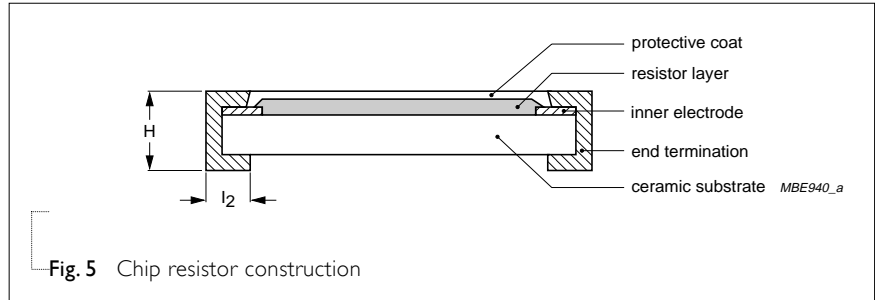

DIMENSION

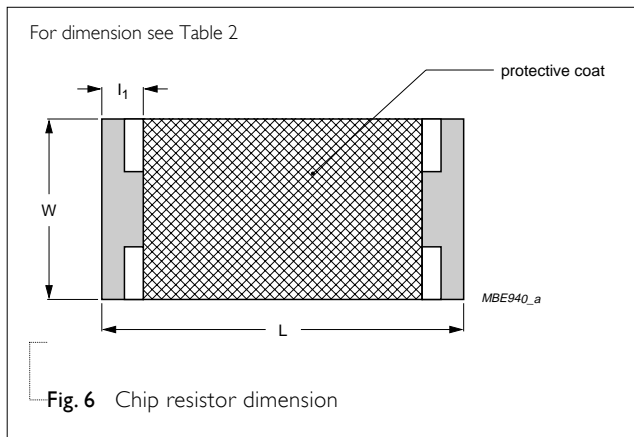

Table 2

TYPE	L (mm)	W (mm)	H (mm)	l ₁ (mm)	l ₂ (mm)
RJ0201	0.6±0.10	0.30±0.05	0.25±0.05	0.15±0.10	0.15±0.10
RJ0402	1.00±0.10	0.50±0.05	0.30±0.05	0.20±0.10	0.25±0.10
RJ0603	1.60±0.10	0.80±0.10	0.45±0.10	0.25±0.15	0.25±0.15
RJ0805	2.00±0.10	1.25±0.10	0.50±0.10	0.35±0.20	0.35±0.20
RJ1206	3.10±0.10	1.60±0.10	0.55±0.10	0.45±0.20	0.40±0.20
RJ1210	3.10±0.10	2.60±0.15	0.55±0.10	0.50±0.20	0.50±0.20
RJ2010	5.00±0.10	2.50±0.15	0.55±0.10	0.60±0.20	0.50±0.20
RJ2512	6.35±0.10	3.20±0.15	0.55±0.10	0.60±0.20	0.50±0.20

POWER RATING

RATED POWER AT 70°C:

RJ0201=1/20W, RJ0402=1/16W, RJ0603=1/16W, RJ0805=1/10W, RJ1206=1/8W, RJ1210=1/4W, RJ2010=1/2W, RJ2512=3/4W

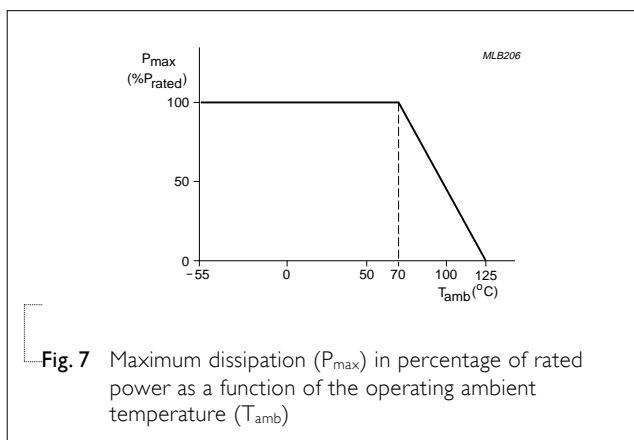

RATED VOLTAGE:

The DC or AC (rms) continuous working voltage corresponding to the rated power is determined by the following formula:

$$V = \sqrt{P \times R}$$

Where

V=Continuous rated DC

or AC (rms) working voltage (V)

P=Rated power (W)

R=Resistance value (Ω)

ELECTRICAL CHARACTERISTICS

Table 2

CHARACTERISTICS	OPERATING TEMPERATURE RANGE	DERATED TO 0 LOAD AT	MAXIMUM WORKING VOLTAGE	DIELECTRIC WITHSTAND VOLTAGE	MAXIMUM OVERTOAD VOLTAGE	RESISTANCE RANGE	TEMPERATURE COEFFICIENT
RJ0201	-55°C to +125°C	+125°C	15V	50V	50V	10Ω~30KΩ	±50ppm/°C
RJ0402	-55°C to +125°C	+125°C	25V	100V	100V	10Ω~121KΩ	±50ppm/°C
RJ0603	-55°C to +125°C	+125°C	50V	100V	100V	3Ω~681KΩ	±50ppm/°C
RJ0805	-55°C to +125°C	+125°C	100V	250V	200V	3Ω~1.5MΩ	±50ppm/°C
RJ1206	-55°C to +125°C	+125°C	150V	250V	250V	3Ω~1.5MΩ	±50ppm/°C
RJ1210	-55°C to +125°C	+125°C	150V	400V	300V	1Ω~1MΩ	±50ppm/°C
RJ2010	-55°C to +125°C	+125°C	150V	400V	300V	10Ω~1MΩ	±50ppm/°C
RJ2512	-55°C to +125°C	+125°C	150V	400V	300V	10Ω~1MΩ	±50ppm/°C

TAPING REEL

Table 4

DIMENSION	RJ0201	RJ0402	RJ0603	RJ0805	RJ1206	RJ1210	RJ2010	RJ2512
PACKAGING	Paper	Paper	Paper	Paper	Paper	Paper	Embossed	Embossed
TAPE WIDTH	8mm	8mm	8mm	8mm	8mm	8mm	12mm	12mm
ØA (mm)	180+0/-3	180+0/-3	180+0/-3	180+0/-3	180+0/-3	180+0/-3	180+0/-3	180+0/-3
ØB (mm)	60+1/-0	60+1/-0	60+1/-0	60+1/-0	60+1/-0	60+1/-0	60+1/-0	60+1/-0
ØC (mm)	13.0±0.2	13.0±0.2	13.0±0.2	13.0±0.2	13.0±0.2	13.0±0.2	13.0±0.2	13.0±0.2
W (mm)	9.0±0.3	9.0±0.3	9.0±0.3	9.0±0.3	9.0±0.3	9.0±0.3	13.0±0.3	13.0±0.3
T (mm)	11.4±1	11.4±1	11.4±1	11.4±1	11.4±1	11.4±1	15.4±1	15.4±1

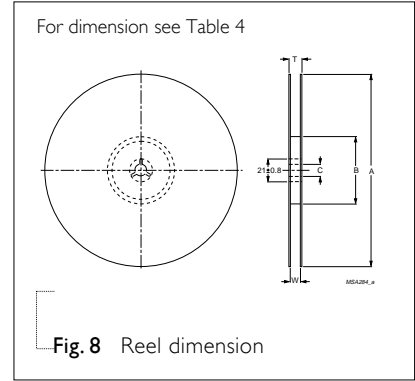

PAPER TAPE SPECIFICATION

Table 5

DIMENSION	RJ0201	RJ0402	RJ0603	RJ0805	RJ1206	RJ1210
A (mm)	0.45±0.1	0.65±0.1	1.10±0.1	1.65±0.1	1.90±0.1	2.80±0.1
B (mm)	0.75±0.1	1.15±0.1	1.90±0.1	2.40±0.1	3.50±0.1	3.50±0.1
W (mm)	8.0±0.2	8.0±0.2	8.0±0.2	8.0±0.2	8.0±0.2	8.0±0.2
E (mm)	1.75±0.1	1.75±0.1	1.75±0.1	1.75±0.1	1.75±0.1	1.75±0.1
F (mm)	3.5±0.05	3.5±0.05	3.5±0.05	3.5±0.05	3.5±0.05	3.5±0.05
P ₀ (mm)	4.0±0.1	4.0±0.1	4.0±0.1	4.0±0.1	4.0±0.1	4.0±0.1
P ₁ (mm)	2.0±0.05	4.0±0.05	4.0±0.05	4.0±0.05	4.0±0.05	4.0±0.05
P ₂ (mm)	2.0±0.05	2.0±0.05	2.0±0.05	2.0±0.05	2.0±0.05	2.0±0.05
ØD ₀ (mm)	1.5+0.1/-0	1.5+0.1/-0	1.5+0.1/-0	1.5+0.1/-0	1.5+0.1/-0	1.5+0.1/-0
T (mm)	0.35±0.10	0.53±0.10	0.70±0.10	0.85±0.10	0.85±0.10	0.85±0.10

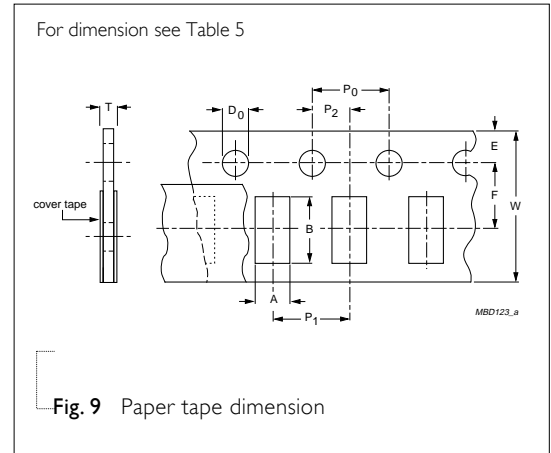

EMBOSSED TAPE SPECIFICATION

Table 6

DIMENSION	RJ2010	RJ2512
A (mm)	2.80±0.2	3.5±0.2
B (mm)	5.4±0.2	6.7±0.2
W (mm)	12.0±0.3	12±0.3
E (mm)	1.75±0.1	1.75±0.1
F (mm)	5.5±0.05	5.5±0.05
P ₀ (mm)	4.0±0.1	4.0±0.1
P ₁ (mm)	4.0±0.1	4.0±0.1
P ₂ (mm)	2.0±0.05	2.0±0.05
ØD ₀ (mm)	1.5+0.1/-0	1.5+0.1/-0
ØD ₁ (mm)	1.5±0.25	1.5±0.25
T (mm)	1.0±0.1	1.0±0.1

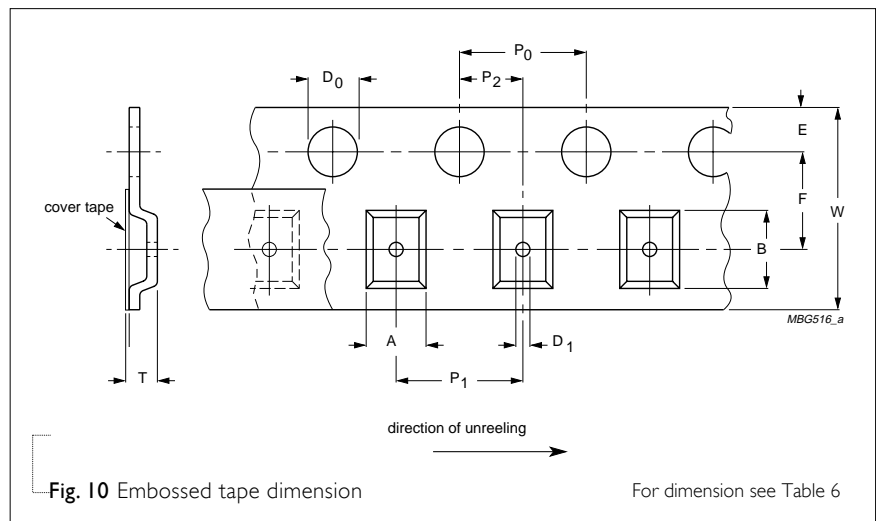

PACKING METHOD

LEADER/TRAILER TAPE SPECIFICATION

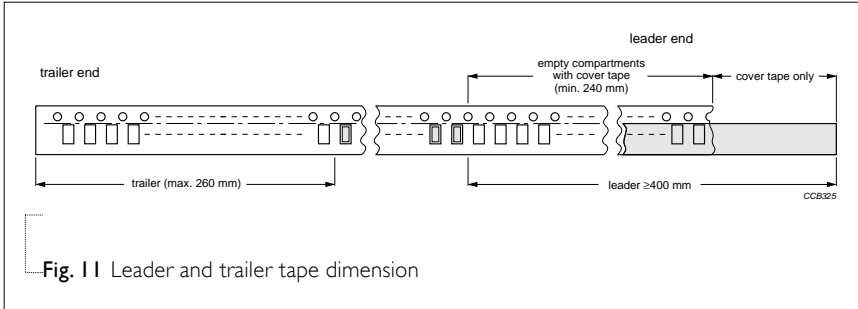

BULK CASSETTE

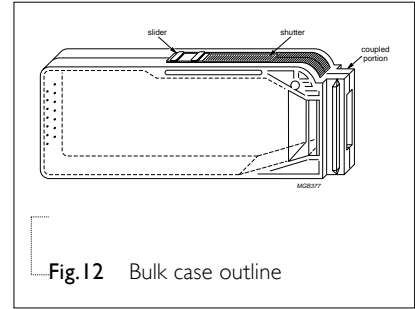
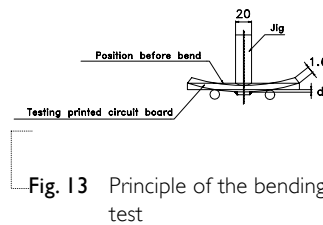

Table 7 Packing style and packaging quantity

PACKING STYLE	REEL DIMENSION	RJ0201	RJ0402	RJ0603	RJ0805	RJ1206	RJ1210	RJ2010	RJ2512
Paper Taping Reel (R)	7" (178 mm)	10,000	10,000	5,000	5,000	5,000	5,000	---	---
	10" (254 mm)	20,000	20,000	10,000	10,000	10,000	10,000	---	---
	13" (330 mm)	50,000	50,000	20,000	20,000	20,000	20,000	---	---
Embossed Taping Reel (K)	7" (178 mm)	---	---	---	---	---	---	4,000	4,000
Bulk Cassette (C)		50,000	50,000	25,000	10,000	---	---	---	---

TYPE	TEST METHOD	ACCEPTANCE STANDARD																		
Temperature Coefficient of Resistance (T.C.R.)	<p>Measure resistance at +25°C or specified room temperature as R₁, then measure at -55°C or +125°C respectively as R₂.</p> <p>Determine the temperature coefficient of resistance from the following formula:</p>	<p>Formula</p> <hr/> $T.C.R. = \frac{R_2 - R_1}{R_1(t_2 - t_1)} \times 10^6 \text{ (ppm/}^\circ\text{C)}$ <p>Where t₁=+25°C or specified room temperature t₂=-55°C or +125°C test temperature R₁=resistance at reference temperature in ohms R₂=resistance at test temperature in ohms</p>	±50ppm/°C																	
Thermal Shock	<p>At -55±3°C for 2 minutes and at +125±2°C for 2 minutes as one cycle. After 25 cycles, the specimen shall be stabilized at room temperature.</p> <p>Measure the resistance to determine ΔR/R(%) after one more hour.</p>	±(0.5%+0.05Ω)																		
Low Temperature Operation	<p>Place the specimen in a test chamber maintained at -65 (+0/-5)°C. After one hour stabilization at this temperature, full rated working voltage shall be applied for 45 (+5/-0) minutes. Have 15 (+5/-0) minutes after remove the voltage, the specimen shall be removed from the chamber and stabilized at room temperature for 24 hrs.</p> <p>Measure the resistance to determine ΔR/R(%).</p>	±(0.5%+0.05Ω) No mechanical damage																		
Short Time Overload	<p>Apply 2.5 times of rated voltage but not exceeding the maximum overload voltage for 5 seconds. Have the specimen stabilized at room temperature for 30 minutes minimum.</p> <p>Measure the resistance to determine ΔR/R(%).</p>	±(1.0%+0.05Ω) for 1.0% tolerance No evidence of mechanical damage																		
Insulation Resistance	<p>Place the specimen in the jig and apply a rated continues overload voltage (R.C.O.V) for one minute.</p> <p>Measure the insulation resistance.</p>	≥10,000MΩ																		
	<table border="1"> <thead> <tr> <th>Type</th> <th>RJ0201</th> <th>RJ0402</th> <th>RJ0603</th> <th>RJ0805</th> <th>RJ1206</th> <th>RJ1210</th> <th>RJ2010</th> <th>RJ2512</th> </tr> </thead> <tbody> <tr> <td>Voltage</td> <td>50V</td> <td>100V</td> <td>100V</td> <td>200V</td> <td>250V</td> <td>300V</td> <td>300V</td> <td>300V</td> </tr> </tbody> </table>	Type	RJ0201	RJ0402	RJ0603	RJ0805	RJ1206	RJ1210	RJ2010	RJ2512	Voltage	50V	100V	100V	200V	250V	300V	300V	300V	
Type	RJ0201	RJ0402	RJ0603	RJ0805	RJ1206	RJ1210	RJ2010	RJ2512												
Voltage	50V	100V	100V	200V	250V	300V	300V	300V												
Dielectric Withstand Voltage	<p>Place the specimen in the jig and apply a specified value continuous overload voltage as shown for one minute.</p>	Breakdown voltage> specification and without open/short																		
	<table border="1"> <thead> <tr> <th>Type</th> <th>RJ0201</th> <th>RJ0402</th> <th>RJ0603</th> <th>RJ0805</th> <th>RJ1206</th> <th>RJ1210</th> <th>RJ2010</th> <th>RJ2512</th> </tr> </thead> <tbody> <tr> <td>Voltage</td> <td>50V</td> <td>100V</td> <td>100V</td> <td>200V</td> <td>250V</td> <td>300V</td> <td>300V</td> <td>300V</td> </tr> </tbody> </table>	Type	RJ0201	RJ0402	RJ0603	RJ0805	RJ1206	RJ1210	RJ2010	RJ2512	Voltage	50V	100V	100V	200V	250V	300V	300V	300V	
Type	RJ0201	RJ0402	RJ0603	RJ0805	RJ1206	RJ1210	RJ2010	RJ2512												
Voltage	50V	100V	100V	200V	250V	300V	300V	300V												
Resistance To Soldering Heat	<p>Immerse the specimen in the solder pot at 260±5°C. for 10±1 seconds. Have the specimen stabilized at room temperature for 30 minutes minimum.</p> <p>Measure the resistance to determine ΔR/R(%).</p>	±(0.5%+0.05Ω) No visible damage																		

TYPE	TEST METHOD	ACCEPTANCE STANDARD
Moisture Resistance	Place the specimen in the test chamber and subject to 42 damp heat cycles. Each one of which consists of the steps 1 to 7 as figure 14. The total length of test is 1,000 hours. Have the specimen stabilized at room temperature for 24 hours after testing. Measure the resistance to determine $\Delta R/R(\%)$.	$\pm(0.5\%+0.05\Omega)$ No visible damage
Life	Place the specimen in the oven at $70\pm 2^{\circ}\text{C}$. Apply the rated voltage to the specimen at the 1.5 hours on and 0.5 hour off cycle. The total length of test is 1,000 hours. Have the specimen stabilized at room temperature for one hour minimum after testing. Measure the $\Delta R/R(\%)$.	$\pm(1\%+0.05\Omega)$ for 1% tolerance
Solderability	Immerse the specimen in the solder pot at $235\pm 5^{\circ}\text{C}$ for 5 sec.	At least 95% solder coverage on the termination
Bending Strength	Mount the specimen on a test board as shown in the figure 13. Slowly apply the force till the board is bent for 5 ± 1 sec. Measure the $\Delta R/R(\%)$ at this position.	$\pm(1.0\%+0.05\Omega)$ for 1% tolerance No visible damage



Type	RJ0201	RJ0402	RJ0603	RJ0805	RJ1206	RJ1210	RJ2010	RJ2512
Spec	2mm	2mm	3mm	3mm	2mm	2mm	2mm	2mm

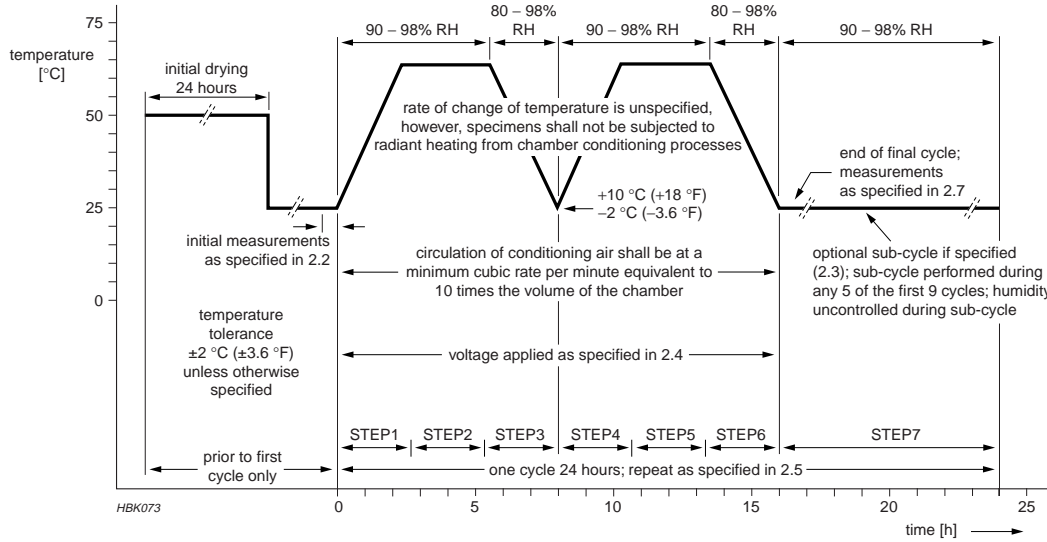

Fig. 14 Conditions by change of temperature