



AK2365A

FM IF Detector with Narrow Band Filter

1. Features

The AK2365A includes 2nd-Mixer, AGC+BPF, PLL FM detector, noise squelch, and RSSI circuit. This device can eliminate E to J type ceramic filters, quadrature discriminator, and other external components.

- Low operating voltage: VDD = 2.6 to 5.5 V
- Wide operating temperature: Ta = -40 to 85 °C
- High sensitivity: -102dBm at 12dB SINAD *De-emphasis + BPF
- Built-in PGA and 2nd Mixer
- Local frequency: 45.9MHz, 50.4MHz, 57.6MHz (Triple of 15.3, 16.8 and 19.2MHz)
- Built-in programmable AGC+BPF circuits corresponding to E to J type ceramic filters
- Built-in PLL FM detector
- RSSI function
- Built-in noise squelch circuits
- Low consumption current: 6mA
- Compact plastic packaging: 32-pin QFNJ (4.0 x 4.0 x 0.75mm, 0.4mm pitch)

2. Applications

- Narrowband high performance professional digital wireless systems
(Channel spacing for 6.25kHz, 12.5kHz)
- Digital convenience radio systems

3. Contents

1. Features.....	1
2. Applications	1
3. Contents	2
4. Block Diagram	3
5. Circuit Configuration	4
6. Pin/Function.....	5
7. Absolute Maximum Ratings	7
8. Recommended Operating Conditions.....	7
9. Digital DC Characteristics	8
10. Digital AC Timing	9
11. Power-up Sequence	11
12. System Reset	11
13. Power Consumption.....	12
14. Analog Characteristics	13
15. Serial Interface Configuration	18
16. Calibration Procedure	25
17. AGC Operation	26
18. Recommended External Application Circuits	27
19. Packaging	31

4. Block Diagram

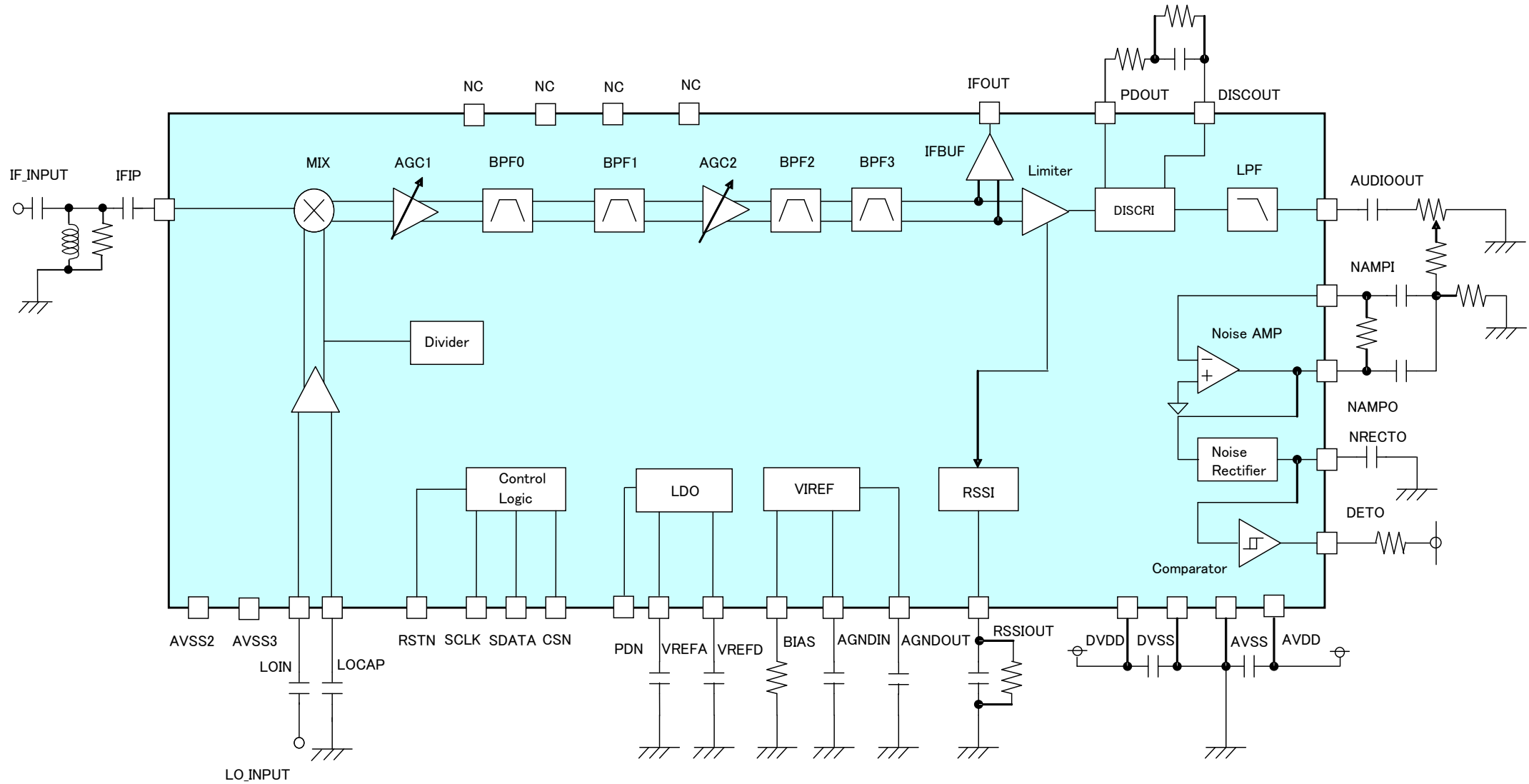

5. Circuit Configuration

Block	Description
MIX	2nd-mixer to convert the input signal down to 450kHz.
AGC+BPF	The circuit composed of AGC and BPF, where the desired signal is amplified and spurious components included in the signal from the 2nd-mixer are eliminated.
IFBUF	The circuit to output filtered signal by AGC+BPF.
Divider	The circuit to divide the signal from LOIN pin.
Limiter	The circuit to amplify the signal filtered at the AGC+BPF stage and generate rectangular wave.
DISCRI	The demodulator circuit with PLL FM detector, where the audio signal is recovered.
LPF	The Low-pass filter to eliminate the noise generated at the DISCRI stage.
Noise AMP	The amplifiers to compose the Band-pass filter for noise squelch.
Noise Rectifier	The rectification circuit to detect the noise level.
Comparator	The circuit to compare the noise level with reference voltage level.
RSSI	The circuit to indicate the Received Signal Strength Indicator (RSSI) by generating a DC voltage corresponding to the input level from Limiter.
VIREF	The circuit to generate internal reference voltage.
LDO	The circuit to supply 1.8V power for some circuits.
Control Logic	The control register controls the status of internal condition by serial data that consists of 1 instruction bit, 6 address bits and 8 data bits.

6. Pin/Function

Package	Signal			Function
	Pin No	Name	Type Conditions at power down	
	1	IFIP	AI Note 1)	IF signal input pin
	2	NC	AIO Z	NC pin
	3	NC	AIO Z	NC pin
	4	NC	AIO Z	NC pin
	5	NC	AIO Z	NC pin
	6	VREFA	AO Low	LDO reference pin Connect the capacitor to stabilize LDO reference voltage.
	7	AVSS	PWR -	Analog VSS power supply pin
	8	AVDD	PWR -	Analog VDD power supply pin
	9	BIAS	AO Z	Output pin to connect bias resistor for reference voltage
	10	NRECTO	AI Note 2)	Output pin for the rectification circuit
	11	NAMPO	AO Z	Output pin for noise squelch amplifier
	12	NAMPI	AI Z	Input pin for noise squelch amplifier
	13	AUDIOOUT	AO Note 3)	Demodulated audio signal output pin
	14	DISCOUT	AO Note 4)	Pin2 for Discriminator Low-pass filter
	15	PDOUT	AO Z	Pin1 for Discriminator Low-pass filter
	16	RSSIOUT	AO Z	Output pin to connect capacitor for Received Signal Strength Indicator(RSSI)
	17	IFOUT	AO Note 5)	Output pin for IFBUF
	18	AVSS2	PWR -	Analog VSS power supply pin
	19	PDN	DI Z	Power down pin for LDO
	20	RSTN	DI Z	Hardware reset pin
	21	CSN	DI Z	Chip select input pin for serial data
	22	SCLK	DI Z	Clock input pin for serial data
	23	SDATA	DB Z	Input and output pin for serial data
	24	DETO	DO Z	Signal detect output pin
	25	DVDD	PWR -	Digital VDD power supply pin.
	26	DVSS	PWR -	Digital VSS power supply pin.
	27	VREFD	AO Low	LDO reference pin Connect the capacitor to stabilize LDO reference voltage.
	28	AVSS3	PWR -	Analog VSS power supply pin
	29	AGNDOUT	AO Low	Analog ground output pin. Connect the capacitor to stabilize the analog ground level.
	30	AGNDIN	AI Low	Analog ground input pin. Connect the capacitor to stabilize the analog ground level.
	31	LOCAP	AI Note 6)	Local signal input pin
	32	LOIN	AI Note 6)	Local signal input pin

Note **A**: Analog, **D**: Digital, **PWR**: Power, **I**: Input, **O**: Output, **B**: Bidirectional, **Z**: High-Z, **L**: Low

Note 1) Connecting internally to VSS pin by 50kΩ

Note 2) Connecting internally to VDD pin by 720kΩ

Note 3) Connecting internally to VSS pin by 830kΩ

- Note 4) Connecting internally to VSS pin by 50kΩ
- Note 5) Connecting internally to VSS pin by 480kΩ
- Note 6) Connecting internally to VDD pin by 139kΩ

• Pin Assignment

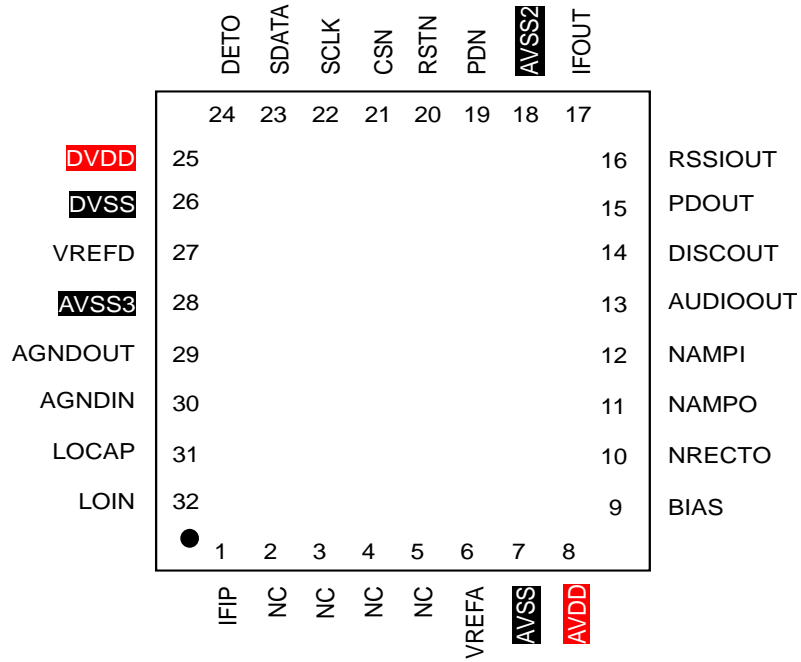

7. Absolute Maximum Ratings

Parameter	Symbol	Min.	Max.	Units
Power Supply Voltage	AVDD	-0.3	6.5	V
	DVDD	-0.3	6.5	V
Ground Level	VSS	0	0	V
Input Voltage	V _{IN} analog	-0.3	AVDD+0.3	V
	V _{IN} digital	-0.3	DVDD+0.3	V
Input Current (Except power supply pin)	I _{IN}	-10	+10	mA
Storage Temperature	T _{stg}	-55	125	°C

Note : All voltages are relative to the VSS pin.

Caution : Exceeding these maximum ratings can result in damage to the device.
Normal operation cannot be guaranteed under this extreme.

8. Recommended Operating Conditions

Parameter	Symbol	Condition	Min.	Typ.	Max.	Units
Operating Temperature	T _a		-40		85	°C
Power Supply Voltage	AVDD		2.6	3.0	5.5	V
	DVDD	DVDD ≤ AVDD	2.6	3.0	5.5	V
Analog Reference Voltage	AGND	AGNDOUT		1/2 VREFA		V
Output Load Resistance	R _{L1}	AUDIOOUT, DISCOUNT, NAMPO	30			kΩ
Output Load Capacitance	C _{L1}	AUDIOOUT, DISCOUNT, NAMPO			15	pF
	C _{L2}	IFOUT		21	26	pF

Note : All voltages are relative to the VSS pin.

9. Digital DC Characteristics

Parameter	Symbol	Condition	Min.	Typ.	Max.	Units
High level input voltage	V_{IH}	RSTN, SCLK, SDATA, CSN, PDN	0.8DVDD			V
Low level input voltage	V_{IL}	RSTN, SCLK, SDATA, CSN, PDN			0.2DVDD	V
High level input current	I_{IH}	$V_{IH}=DVDD$ RSTN, SCLK, SDATA, CSN, PDN			10	μA
Low level input current	I_{IL}	$V_{IL}=0V$ RSTN, SCLK, SDATA, CSN, PDN	-10			μA
High level output voltage	V_{OH}	$I_{OH}=+0.2mA$ SDATA	DVDD-0.4		DVDD	V
Low level output voltage	V_{OL}	$I_{OL}=-0.4mA$ SDATA, DETO	0.0		0.4	V

10. Digital AC Timing

1) Serial Interface Timing

AK2365A is connected to a CPU by three-wired interface through CSN, SCLK and SDATA pins, which can make reading and writing data for control registers.

Serial data named SDATA is consist of 1-bit read and write instruction(R/W), 6-bit address (A5 to A0) and 8-bit data(D7 to D0) in one frame.

Write mode

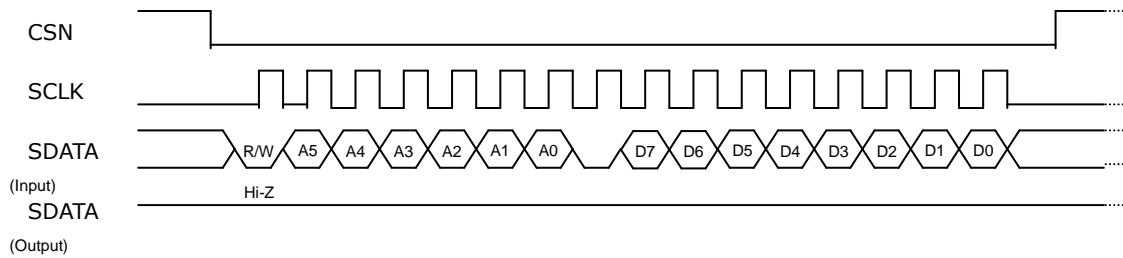

Read mode

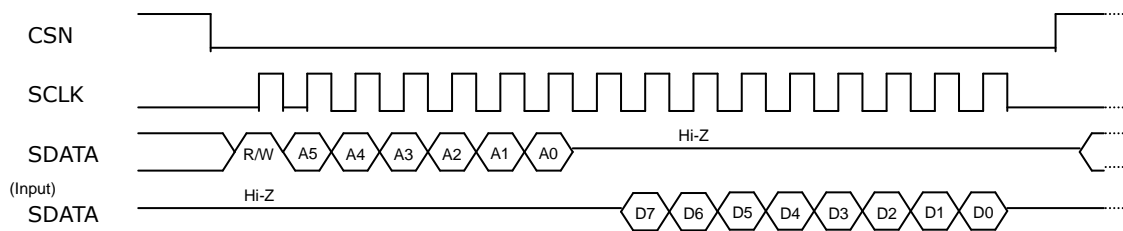

R/W : Instruction bit controls to write data to AK2365A or read back from it.
When set to low, AK2365A is in write mode. When set to high, AK2365A is in read mode.

A5 to A0: Register address to be accessed.

D7 to D0: Write or read data to be accessed.

- <1> CSN(Chip select) is normally selected high for disable.
When CSN is set to low, serial interface becomes active.
- <2> In write mode, instruction, address and data input from SDATA pin are synchronized and latched with the rising edge of 16 iterations of SCLK clock. Set to low between address A0 and data D7. Input data is fixed synchronized with the rising edge of 16th clock. Note that if CSN become "H" before 16th clock, setting data becomes invalid. During the period when CSN is set to "L", consecutive writing is available.
- <3> In read mode, instruction and address are synchronized and latched with the rising edge of 7 iterations of SCLK clock. And the register data are output from SDATA pin synchronized with the falling edge of 9 iterations of SCLK clock. The data between address A0 and data D7 is unstable. During the period when data is output, input to SDATA must be "Hi-z". Set CSN to "H" once reading is completed because consecutive reading is not valid.

2) Detail Timing Chart

Write mode

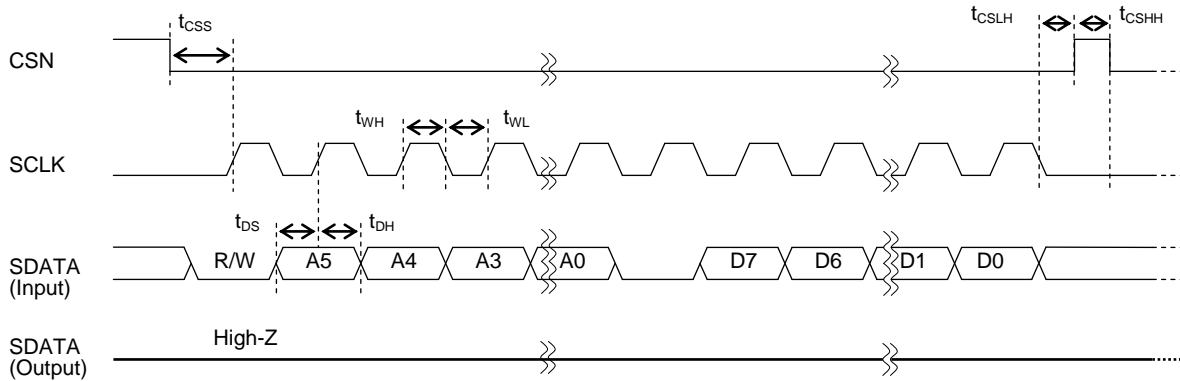

Read mode

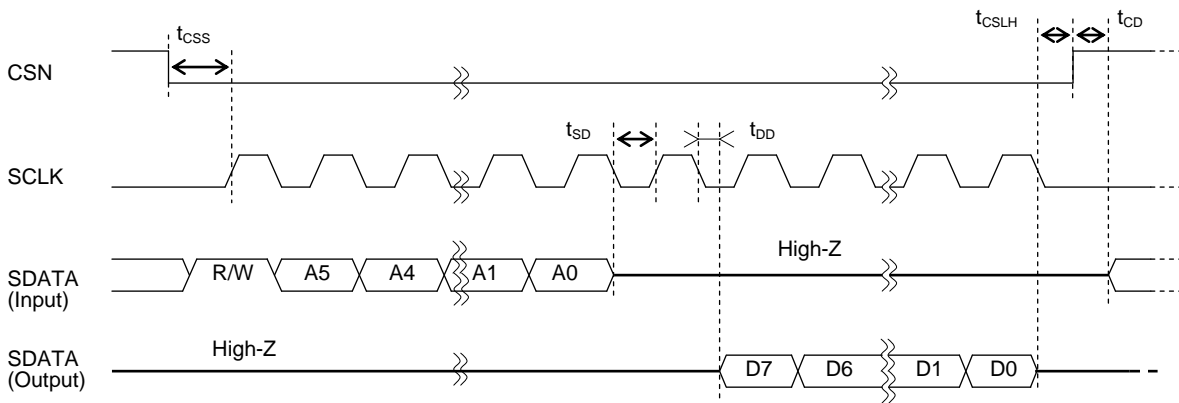

Rising and falling time

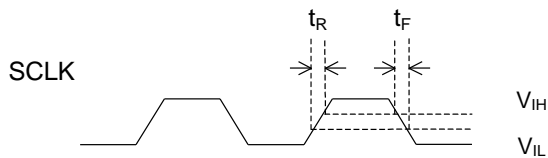

Parameter	Symbol	Condition	Min.	Typ.	Max.	Unit
CSN setup time	t_{CSS}		100			ns
SDATA setup time	t_{DS}		100			ns
SDATA hold time	t_{DH}		100			ns
SCLK high time	t_{WH}		500			ns
SCLK low time	t_{WL}		500			ns
CSN low hold time	t_{CSLH}		100			ns
CSN high hold time	t_{CSHH}		100			ns
SDATA Hi-Z setup time	t_{SD}		500			ns
SCLK to SDATA output delay time	t_{DD}	20pF load			400	ns
CSN to SDATA input delay time	t_{CD}	20pF load	200			ns
SCLK rising time	t_R				250	ns
SCLK falling time	t_F				250	ns

Note) Digital input and output timing is relative to 0.5DVDD of rising signal and falling signal.

11. Power-up Sequence

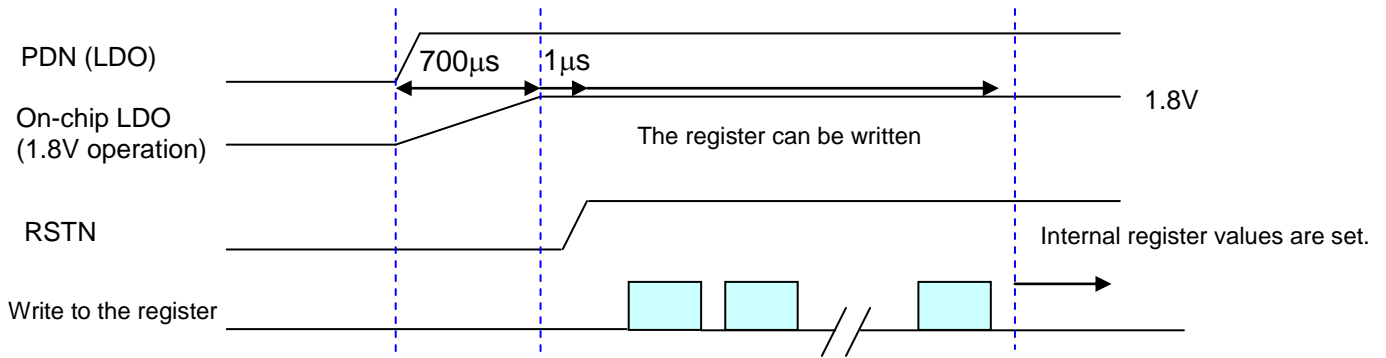

Note) After PDN is set to “High”, registers remain undefined. In order to initialize them, RSTN is set to “High”

12. System Reset

Parameter	Symbol	Condition	Min.	Typ.	Max.	Unit	Remarks
Hardware reset signal input width	t_{RSTN}	RSTN pin	1			µs	*1)
Software reset		SRST register					*2)

*1) After power-on, be sure to perform a hardware reset operation (register initialization). The system is reset by a low pulse input of 1µs (min.) and enters the normal operation state. At this moment, the digital (DI) pins are set as follows: RSTN pin to High, SCLK pin to Low, SDATA pin to Low, CSN pin to Low.

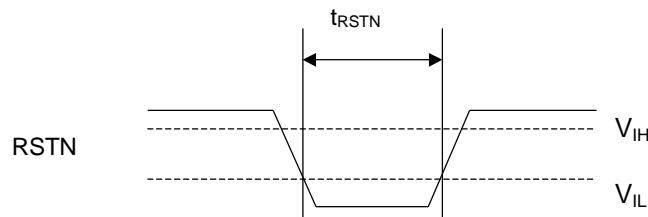

*2) When data 0x04:10101010 is written to the SRST[7:0] register, software reset is performed. This setting initializes the registers and the operation mode is set to mode 2 (Standby 2). After software reset is completed, this register comes to “0”.

13. Power Consumption

Parameter	Symbol	Condition	Min.	Typ.	Max.	Units
Power Consumption	IDD0	Mode 0 Power down			0.01	mA
	IDD1	Mode 1 (Prohibited)			-	
	IDD2	Mode 2 Standby(initial value)		0.4	0.7	
	IDD3	Mode 3		1	1.6	
	IDD4	Mode 4 Digital Mode 1 with no signal input		5.6	7.5	
	IDD5	Mode 5 Digital Mode 2 with no signal input		6	8	
	IDD6	Mode 6 Analog Mode with no signal input		6	8	
	IDD7	Mode 7 Full Power On with no signal input		7	9.8	

Note 1) Do not use Mode1.

14. Analog Characteristics

For the following conditions unless otherwise specified: Mode 6, LOIN=50.4MHz, IFIP=50.85MHz, $\Delta f = \pm 1.5\text{kHz}$, $f_{\text{mod}} = 1\text{kHz}$, AGC+BPF=F2, {AGC_OFF}=0, the exposure back pad of the package is connected to VSS, with the external circuit shown in example page 26 to 28.

1) Local

Parameter	Symbol	Condition	Min.	Typ.	Max.	Units	Notes
Local Frequency	F_{LO}	LOIN		45.9 50.4 57.6		MHz	
Input amplitude	V_{LO}	LOIN	0.2		2.0	V_{PP}	Note 1)

Note 1) Input from LOIN pin through DC cut

2) 2nd Mixer

Parameter	Condition	Min.	Typ.	Max.	Units	Notes
Input Impedance			50		Ω	Note 2)
Input Frequency			F_{LO} ± 0.45		MHz	
Voltage Gain			28		dB	

Note 2) Include external matching circuit

3) Discriminator

Parameter	Condition	Min.	Typ.	Max.	Units	Notes
Demodulation Output Level	$\Delta f = \pm 3.0\text{kHz}$, $f_{\text{mod}} = 1\text{kHz}$, LIMITER IN to AUDIOOUT {BAND}=1	70	100	130	mVrms	
	$\Delta f = \pm 1.5\text{kHz}$, $f_{\text{mod}} = 1\text{kHz}$, LIMITER IN to AUDIOOUT {BAND}=0	70	100	130	mVrms	
S/N Ratio	$\Delta f = \pm 3.0\text{kHz}$, $f_{\text{mod}} = 1\text{kHz}$, $V_{\text{in}} = -16\text{dBm}$ LIMITER IN to AUDIOOUT {BAND}=1	43	50		dB	Note 3)

Note 3) With De-emphasis + BPF(0.3 to 3kHz)

4) RX Overall Characteristics

Parameter	Condition	Min.	Typ.	Max.	Units	Notes
12dB SINAD Input Sensitivity			-102		dBm	Note 4)
Total Gain	Mode 5 Maximum gain setting for AGC IFIP to IFOUT {IFOG[1:0]}=00		84		dB	
	Mode 5 Minimum gain setting for AGC IFIP to IFOUT {IFOG[1:0]}=00		32		dB	
C/N ratio	Mode 5, BPF=F3 IFIP to IFOUT When in CW, 450kHz, -102dBm Bandwidth: 450kHz \pm 3kHz {IFOG[1:0]}=00		17			
IIP3	Mode 5 Maximum gain setting for AGC IFIP=50.8635MHz&50.876MHz		-20		dBm	
Demodulation Output Level	$\Delta f = \pm 3.0\text{kHz}$, $f_{\text{mod}} = 1\text{kHz}$, AGC+BPF=F1, {BAND}=1	70	100	130	mVrms	
	$\Delta f = \pm 1.5\text{kHz}$, $f_{\text{mod}} = 1\text{kHz}$, AGC+BPF=F2, {BAND}=0	70	100	130	mVrms	
S/N Ratio	$\Delta f = \pm 3.0\text{kHz}$, $f_{\text{mod}} = 1\text{kHz}$, AGC+BPF=F1, $V_{\text{in}} = -47\text{dBm}$ {BAND}=1	40	50		dB	Note 4)
	$\Delta f = \pm 1.5\text{kHz}$, $f_{\text{mod}} = 1\text{kHz}$, AGC+BPF=F2, $V_{\text{in}} = -47\text{dBm}$ {BAND}=0	34	44		dB	Note 4)

Note 4) With De-emphasis+BPF(0.3 to 3kHz)

5) RSSI Characteristics

Parameter	Condition	Min.	Typ.	Max.	Units	Notes
RSSI Output Voltage	IFIP to RSSIOUT {AGC_OFF}=0, IFIP=-100dBm Input	0.05	0.3	0.7	V	
	IFIP to RSSIOUT {AGC_OFF}=0, IFIP=-30dBm Input	1.4	2.0	2.6	V	

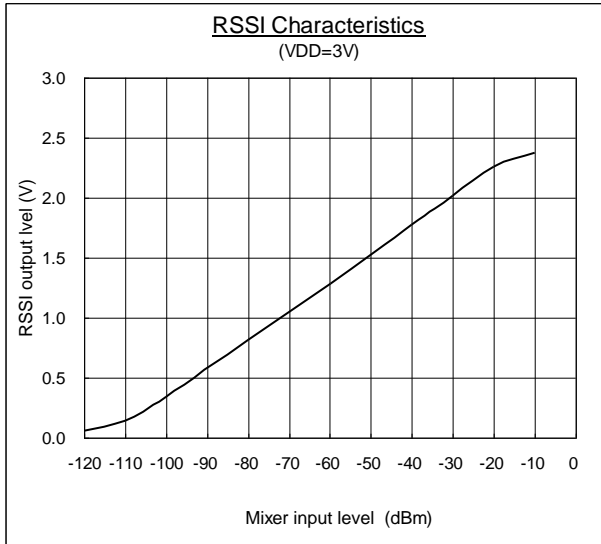

6) Noise Squelch Characteristics

Parameter	Condition	Min.	Typ.	Max.	Units	Notes
Noise Detection Level	NRECTO to DETO Detect High		0.5	0.7	V	
	NRECTO to DETO Detect Low	0.3	0.4		V	
Noise Detection Characteristic	NAMPI to NRECTO Input: 31kHz, 0.1mVrms	0.2	0.3	0.4	V	
	NAMPI to NRECTO Input: 31kHz, 0.25mVrms	0.5	0.65	0.8	V	

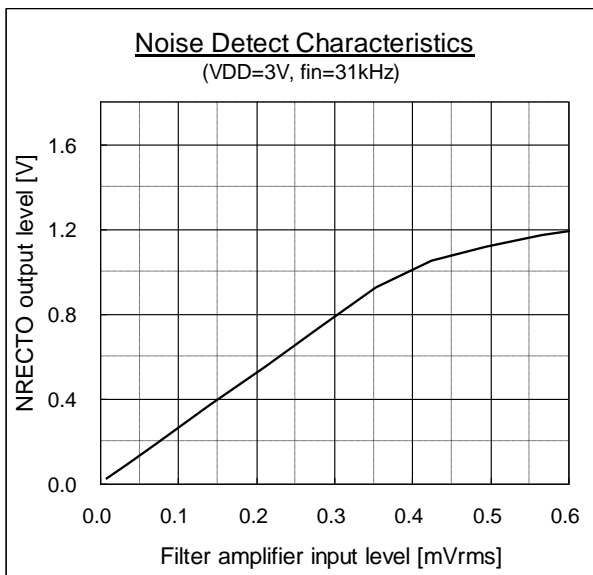

7) AGC+BPF Characteristics

7.1) F0 (E type)

Parameter	Condition	Min.	Typ.	Max.	Units	Notes
Attenuation Characteristics (relative to the gain at 450kHz)	435kHz			-50	dB	
	442.5kHz	-6			dB	
	457.5kHz	-6			dB	
	465kHz			-50	dB	
Gain ripple	Within 450±5kHz			3	dB	

7.2) F1 (F type)

Parameter	Condition	Min.	Typ.	Max.	Units	Notes
Attenuation Characteristics (relative to the gain at 450kHz)	437.5kHz			-50	dB	
	444kHz	-6			dB	
	456kHz	-6			dB	
	462.5kHz			-50	dB	
Gain ripple	Within 450±4kHz			3	dB	

7.3) F2 (G type)

Parameter	Condition	Min.	Typ.	Max.	Units	Notes
Attenuation Characteristics (relative to the gain at 450kHz)	439kHz			-50	dB	
	445.5kHz	-6			dB	
	454.5kHz	-6			dB	
	461kHz			-50	dB	
Gain ripple	Within 450±3kHz			3	dB	

7.4) F3 (H type)

Parameter	Condition	Min.	Typ.	Max.	Units	Notes
Attenuation Characteristics (relative to the gain at 450kHz)	441kHz			-50	dB	
	447kHz	-6			dB	
	453kHz	-6			dB	
	459kHz			-50	dB	
Gain ripple	Within 450±2kHz			2	dB	

7.5) F4 (J type)

Parameter	Condition	Min.	Typ.	Max.	Units	Notes
Attenuation Characteristics (relative to the gain at 450kHz)	443kHz			-50	dB	
	448kHz	-6			dB	
	452kHz	-6			dB	
	457kHz			-50	dB	
Gain ripple	Within 450±1.5kHz			2	dB	

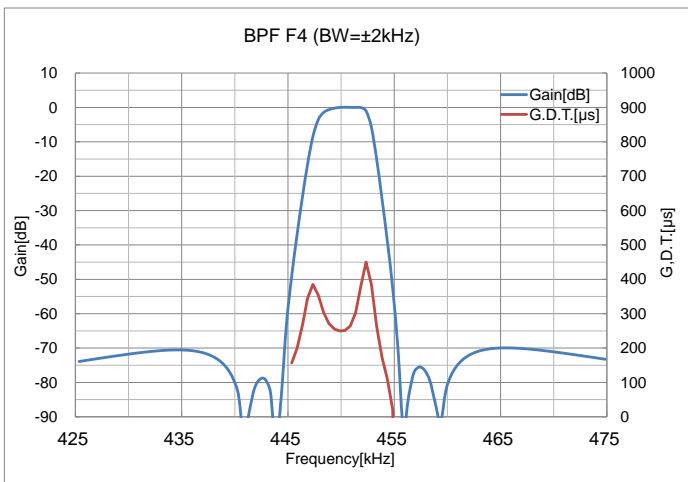
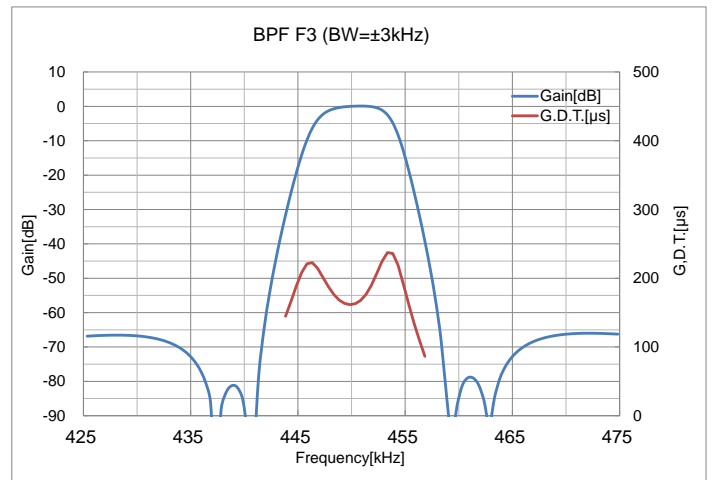
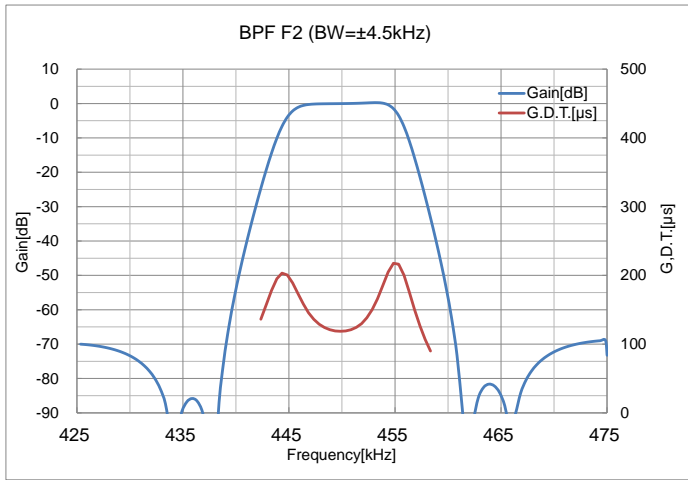
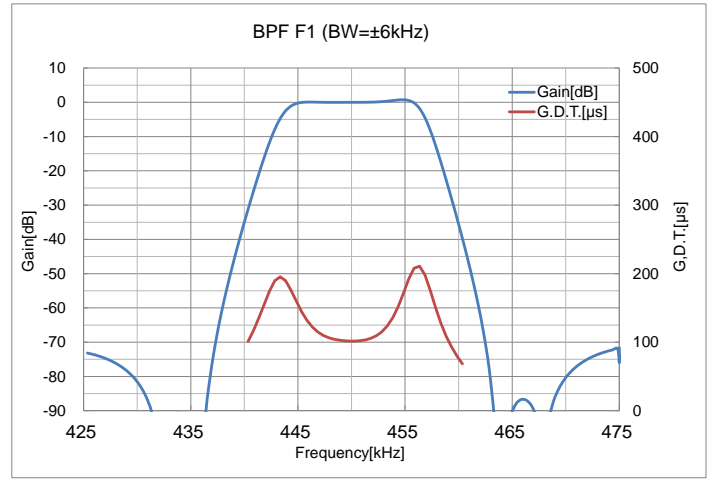
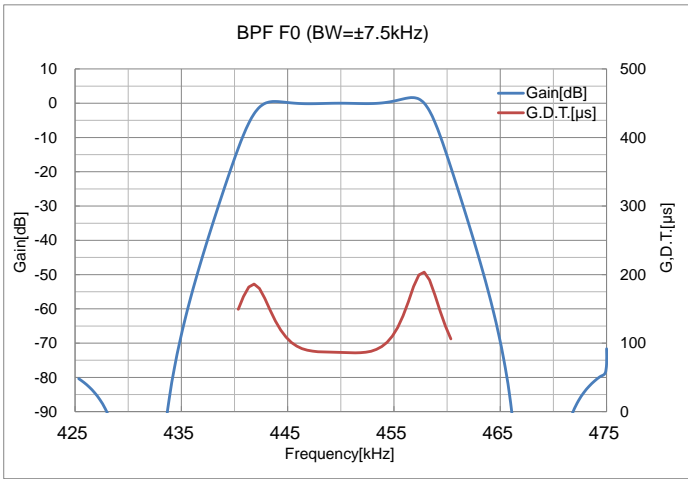

8) IFBUF Characteristics

Parameter	Condition	Min.	Typ.	Max.	Units	Notes
Settling time	IFBUF to IFOUT, IFBUF=0.32Vpp/step C _{L2} =21pF, {IFOG[1:0]}=00		100		ns	

Note: Convergence time within 1% when 0.32Vpp step signal input to IFBUF pin

15. Serial Interface Configuration

1) Register Configuration

Name	ADRS	D7(MSB)	D6	D5	D4	D3	D2	D1	D0(LSB)	W/R	
Control register 1	0x01	BS[2:0]			BAND	BPF_BW[1:0]		LOFREQ[1:0]		W/R	
		0	1	0	0	0	0	0	1		
Control register 2	0x02	Reserved	AGC_KEEP	AGC_FAST	Reserved	AGC_TIME[1:0]		AGC1_STEP	CAL	W/R	
		0	0	1	1	0	0	1	0		
Control register 3	0x03	Reserved						IFOG[1:0]		W/R	
		0	0	0	0	0	0	0	0		
Software -reset	0x04	SRST[7:0]								W	
		—	—	—	—	—	—	—	—		
Reserved	0x05 to 0x0A	Reserved								—	
Control register 4	0x0B	BPF_BW [2]	AGC_OFF	AGC1_G[5:0]						W/R	
		0	0	0	0	0	0	0	0		1
Control register 5	0x0C	Reserved			AGC2_G[4:0]						W/R
		1	0	0	0	0	0	0	0	0	

Note: Do not access the data except specified address above.

2) Description of registers

Address 0x01 (Control Register 1)

Name	D7(MSB)	D6	D5	D4	D3	D2	D1	D0(LSB)
Control Register 1	BS[2:0]			BAND	BPF_BW[1:0]		LOFREQ[1:0]	
Initial Value	0	1	0	0	0	0	0	1

BS[2:0]: Operation mode setting

PDN pin	BS[2]	BS[1]	BS[0]	Mode name	LDOD	LDOA, AGNDIN	VREF	MIX AGC, BPF, Divider	IFBUF	Limiter, RSSI	DISCRI, Noise Squelch
0	-	-	-	Mode 0 (Power-down)	OFF	OFF	OFF	OFF	OFF	OFF	OFF
1	0	0	1	Mode 1 (Note1)	<u>ON</u>	OFF	OFF	OFF	OFF	OFF	OFF
1	0	1	0	Mode 2 (initial value)	<u>ON</u>	<u>ON</u>	OFF	OFF	OFF	OFF	OFF
1	0	1	1	Mode 3	<u>ON</u>	<u>ON</u>	<u>ON</u>	OFF	OFF	OFF	OFF
1	1	0	0	Mode 4	<u>ON</u>	<u>ON</u>	<u>ON</u>	<u>ON</u>	<u>ON</u>	OFF	OFF
1	1	0	1	Mode 5	<u>ON</u>	<u>ON</u>	<u>ON</u>	<u>ON</u>	<u>ON</u>	<u>ON</u>	OFF
1	1	1	0	Mode 6	<u>ON</u>	<u>ON</u>	<u>ON</u>	<u>ON</u>	OFF	<u>ON</u>	<u>ON</u>
1	1	1	1	Mode 7	<u>ON</u>	<u>ON</u>	<u>ON</u>	<u>ON</u>	<u>ON</u>	<u>ON</u>	<u>ON</u>

Note1: Do not use Mode1.

Note2: Do not set the combination of the code which is not defined in the table given above.

BAND: Demodulated signal level setting

BAND	Function
0	Narrow
1	Wide

Note1: When {BAND} register is set to "0", demodulated signal level at AUDIOOUT pin, when input signal is $\Delta f = \pm 1.5\text{kHz}$ dev, is 100mVrms typ. When {BAND} register is set to "1", demodulated signal level at AUDIOOUT pin, when input signal is $\Delta f = \pm 3.0\text{kHz}$ dev, is 100mVrms typ.

BPF_BW[1:0]: BPF band width setting

BPF_BW [2]	BPF_BW [1]	BPF_BW [0]	name	6dB attenuation	Attenuation band width
1	0/1	0/1	F0	$\pm 7.5\text{kHz}$	$\pm 15\text{kHz}$
0	0	0	F1	$\pm 6\text{kHz}$	$\pm 12.5\text{kHz}$
0	0	1	F2	$\pm 4.5\text{kHz}$	$\pm 11\text{kHz}$
0	1	0	F3	$\pm 3\text{kHz}$	$\pm 9\text{kHz}$
0	1	1	F4	$\pm 2\text{kHz}$	$\pm 7\text{kHz}$

LOFREQ[1:0]: Local frequency setting

LOFREQ [1]	LOFREQ [0]	Local frequency
0	0	45.9MHz
0	1	50.4MHz
1	0	57.6MHz

Note: Do not set the combination of the code which is not defined in the table given above.

Address 0x02 (Control Register 2)

Name	D7(MSB)	D6	D5	D4	D3	D2	D1	D0(LSB)
Control Register 2	Reserved	AGC_KEEP	AGC_FAST	Reserved	AGC_TIME[1:0]		AGC1_STEP	CAL
Initial Value	0	0	1	1	0	0	1	0

AGC_KEEP : The function of AGC1/2 gain keeping

When the AGC function is active, the gain setting of AGC1/2 is kept during AGC_KEEP="1". On the other hand, the gain setting of AGC1/2 is changed by IFIP signal during AGC_KEEP="0".

0: The gain setting of AGC1/2 is changed by IFIP signal. (default)

1: The gain setting of AGC1/2 is kept.

Note: When setting the operation mode 4,5,6,7, AGC_KEEP is available.

AGC_FAST : AGC control switching

0: The time constant of response time is changed by conditions that AGC1/AGC2 output level converges between the upper limit and lower limit (convergence) or not (attack/release).

attack/release : AGC response time is the same as AGC_TIME[1:0]="00".

convergence : AGC response time is set with AGC_TIME[1:0].

This setting provides the fast response time that can be followed the burst signal.

(recommended)

1: AGC control is operated with AGC response time described in AGC_TIME[1:0]. (default)

Note : The response speed of AGC must be set to AGC_FAST=0, AGC_TIME[1:0]="11", AGC1_STEP=0. ACS (Adjacent Channel Selectivity) performance is optimized by preventing the periodic operation due to a strong unwanted signal.

AGC_TIME[1:0]: AGC response time setting

This register set response time for AGC1 gain and AGC2 gain to change by 1step.

AGC_TIME [1]	AGC_TIME [0]	AGC response time [ms]					
		AGC1_STEP=0 setting			AGC1_STEP=1 setting		
		State A	State B	State C	State A	State B	State C
0	0	0.56	8.50	8.50	0.38	4.35	4.35
0	1	0.92	8.79	8.79	0.56	4.50	4.50
1	0	1.64	9.37	9.37	0.93	4.79	4.79
1	1	3.08	10.52	10.52	1.66	5.38	5.38

Note 1: Values above indicate response time during AGC gain changes from maximum to minimum or from minimum to maximum.

Note 2: The response speed of AGC must be set to AGC_FAST=0, AGC_TIME[1:0]="11", AGC1_STEP=0. ACS (Adjacent Channel Selectivity) performance is optimized by preventing the periodic operation due to a strong unwanted signal.

State A: AGC1 output level is beyond the upper limit.

State B: AGC1 output level is within the upper limit and AGC2 output level is beyond the upper limit.

State C: AGC2 output level is under the lower limit.

Data	Function	Operation		Notes
		0	1	
AGC1_ST EP	AGC1 gain switching range setting (Note1)	±1dB(recommended)	±2dB	
CAL	Discriminator circuit calibration start trigger (Note2)	Invalid	Start	

Note 1: The response speed of AGC must be set to AGC_FAST=0, AGC_TIME[1:0]="11", AGC1_STEP=0. ACS (Adjacent Channel Selectivity) performance is optimized by preventing the periodic operation due to a strong unwanted signal.

Note 2: calibration is performed synchronized with the rising edge of {CAL}. After calibration is completed, this register is set to "0" automatically. It takes 1.3ms before calibration is completed.

Refer to "calibration procedure" for further information.

Address 0x03 (Control Register 3)

Name	D7(MSB)	D6	D5	D4	D3	D2	D1	D0(LSB)
Control Register 3	Reserved						IFOG[1:0]	
Initial Value	0	0	0	0	0	0	0	0

IFOG[1:0]: IFBUF Gain setting

IFOG [1]	IFOG [0]	IFBUF Gain[dB]
0	0	6
0	1	9
1	0	12
1	1	15

Address 0x04 (Software Reset)

Name	D7(MSB)	D6	D5	D4	D3	D2	D1	D0(LSB)
Software-reset	SRST[7:0]							
Initial Value	—	—	—	—	—	—	—	—

When data 0x04:10101010 is written to the SRST[7:0] register, software reset is performed. Refer to System Reset for further information.

Address 0x0B (Control Register 4)

Name	D7(MSB)	D6	D5	D4	D3	D2	D1	D0(LSB)
Control Register 4	BPF_BW [2]	AGC_OFF	AGC1_G[5:0]					
Initial Value	0	0	0	0	0	0	0	1

Data	Function	Operation		Notes
		0	1	
BPF_BW[2]	F0 (±7.5kHz)	OFF	ON	
AGC_OFF	AGC function	Disable (AGC Auto operation)	Enable (AGC manual operation)	
AGC1_G[5:0]	AGC1 gain adjustment	21 to -19dB by 1dB step		Available only {AGC_OFF}=1

AGC1_G[5]	AGC1_G[4]	AGC1_G[3]	AGC1_G[2]	AGC1_G[1]	AGC1_G[0]	Gain [dB]
0	1	0	1	0	1	21
0	1	0	1	0	0	20
0	1	0	0	1	1	19
0	1	0	0	1	0	18
0	1	0	0	0	1	17
0	1	0	0	0	0	16
0	0	1	1	1	1	15
0	0	1	1	1	0	14
0	0	1	1	0	1	13
0	0	1	1	0	0	12
0	0	1	0	1	1	11
0	0	1	0	1	0	10
0	0	1	0	0	1	9
0	0	1	0	0	0	8
0	0	0	1	1	1	7
0	0	0	1	1	0	6
0	0	0	1	0	1	5
0	0	0	1	0	0	4
0	0	0	0	1	1	3
0	0	0	0	1	0	2
0	0	0	0	0	1	1
0	0	0	0	0	0	0
1	1	1	1	1	1	-1
1	1	1	1	1	0	-2
1	1	1	1	0	1	-3
1	1	1	1	0	0	-4
1	1	1	0	1	1	-5
1	1	1	0	1	0	-6
1	1	1	0	0	1	-7
1	1	1	0	0	0	-8
1	1	0	1	1	1	-9
1	1	0	1	1	0	-10
1	1	0	1	0	1	-11
1	1	0	1	0	0	-12
1	1	0	0	1	1	-13
1	1	0	0	1	0	-14
1	1	0	0	0	1	-15
1	1	0	0	0	0	-16
1	0	1	1	1	1	-17
1	0	1	1	1	0	-18
1	0	1	1	0	1	-19

Note: Do not set the combination of the code which is not defined in the table given above.

Address 0x0C (Control Register 5)

Name	D7(MSB)	D6	D5	D4	D3	D2	D1	D0(LSB)
Control Register 5	Reserved			AGC2_G[4:0]				
Initial Value	1	0	0	0	0	0	0	0

Data	Function	Operation		Notes
		0	1	
AGC2_G[4:0]	AGC2 gain adjustment	12 to 0dB by 1dB step		Available only {AGC_OFF}=1

AGC2_G[4]	AGC2_G[3]	AGC2_G[2]	AGC2_G[1]	AGC2_G[0]	Gain [dB]
0	1	1	0	0	12
0	1	0	1	1	11
0	1	0	1	0	10
0	1	0	0	1	9
0	1	0	0	0	8
0	0	1	1	1	7
0	0	1	1	0	6
0	0	1	0	1	5
0	0	1	0	0	4
0	0	0	1	1	3
0	0	0	1	0	2
0	0	0	0	1	1
0	0	0	0	0	0

Note: Do not set the combination of the code which is not defined in the table given above.

16. Calibration Procedure

AK2365A employs a function to calibrate free-running frequency of VCO in Discriminator and demodulated signal level. Before starting RX Operation, calibration is required in order to acquire proper VCO operation range and demodulated signal level.

Following procedure is required before calibration.

- <1> Start up the external TCXO and continuously supply LO signal to AK2365A.
- <2> Set "11" to 0x01 {BS[2:0]} and start up all circuits. After this operation, the circuits necessary for calibration (LOBUF, VIREF, Discriminator) will be powered on and calibration can be possible in 500us.
- <3> Calibration is begun by setting "1" to address 0x02 {CAL}. When the calibration is executed once, the calibration operation cannot be stopped excluding master reset. Even if "0" is written in {CAL}, the calibration is completely executed.
- <4> Calibration data is maintained excluding the time when the master reset is executed or DVDD power supply is down.
- <5> It takes 1.5ms for Discriminator to become steady after the calibration is completed.

Power-up sequence recommendation

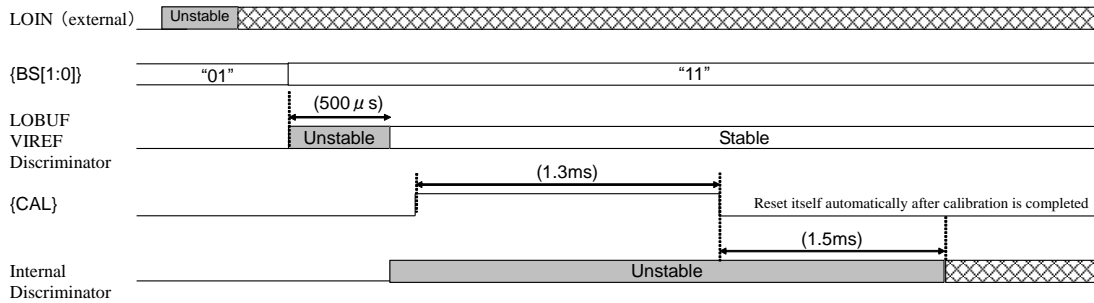

17. AGC Operation

AK2365A has two AGC circuits, AGC1 and AGC2. The signal level from IFIP pin is adjustable automatically by AGC1/2. The following graphs show IFIP input vs. IFOUT output characteristics by setting {AGC1_STEP}=0/1, {IFOG[1:0]}=00, {AGC_OFF}=0. Setting {AGC_OFF}=1 can disable automatic gain adjustable operation and also enable manual gain operation by {AGC1_G[5:0]}, {AGC2_G[4:0]} registers.

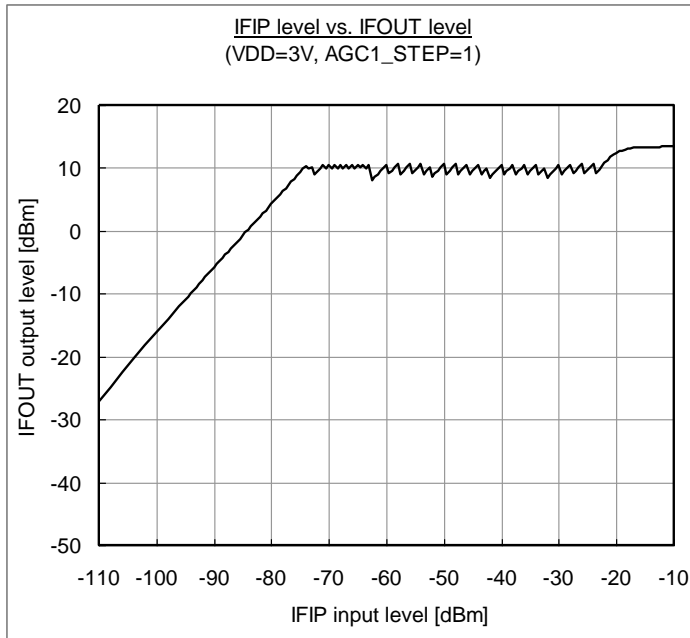
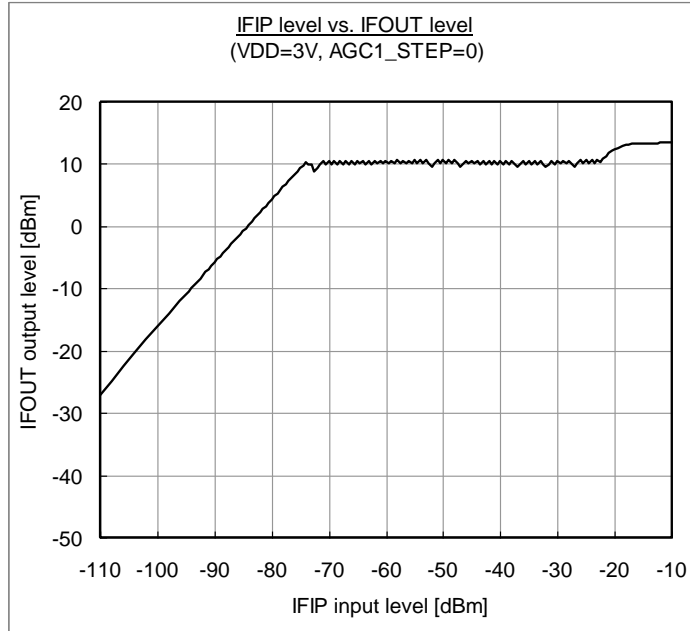

18. Recommended External Application Circuits

1) Power supply stabilizing capacitors

Connect capacitors between VDD and VSS pins to eliminate ripple and noise included in power supply. For maximum effect, the capacitors should be placed at a shortest distance between the pins.

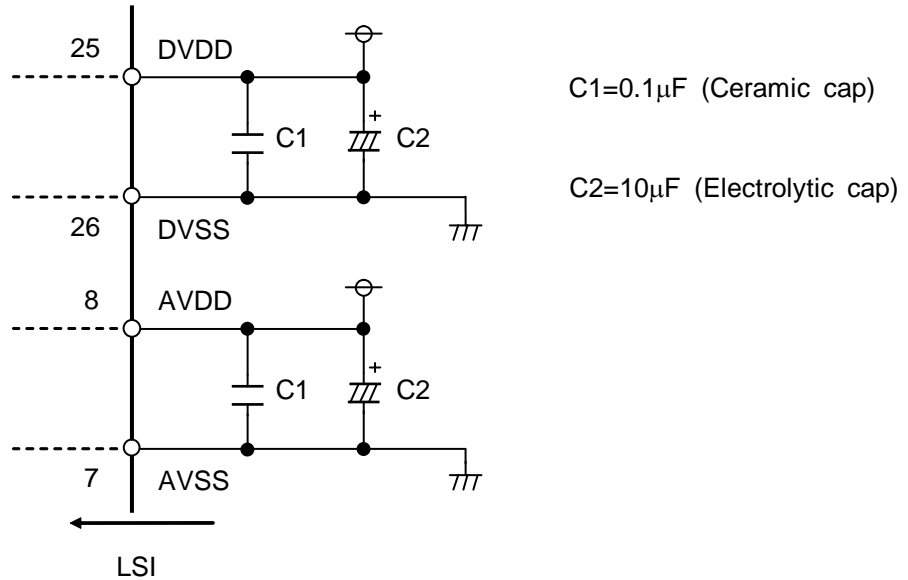

2) AGND stabilizing capacitors

It is recommended that capacitors with 1 μ F or larger be connected between VSS and the AGND and AGNDIN pins to stabilize the AGND signal. The capacitors must be placed as close to the pins as possible.

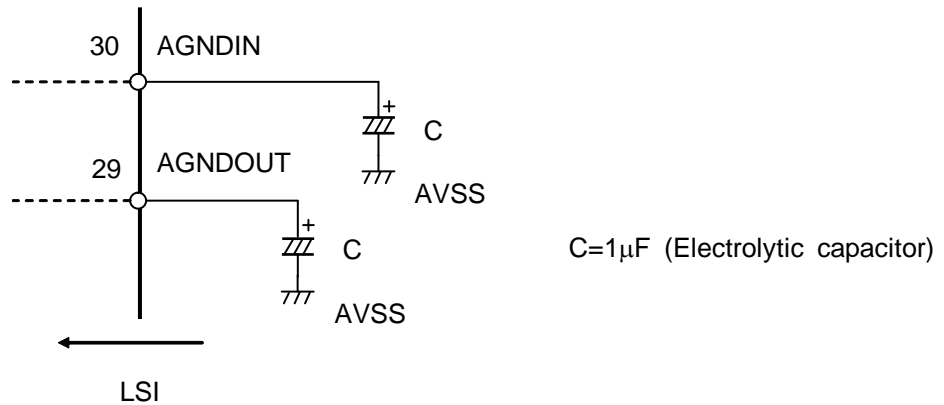

3) BIAS pin

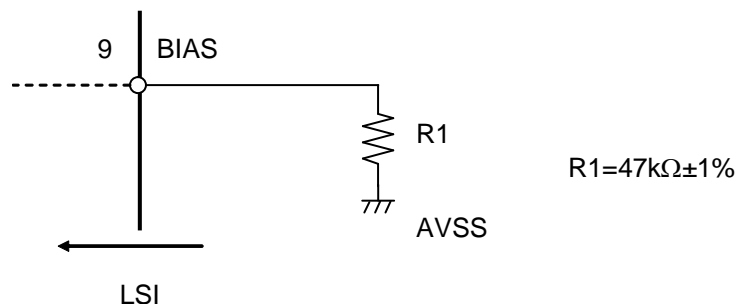

4) VREFA output

It is recommended that capacitors with 220nF or larger be connected between AVSS and VREFA pin to stabilize the VREFA signal. The capacitors must be placed as close to the pins as possible.

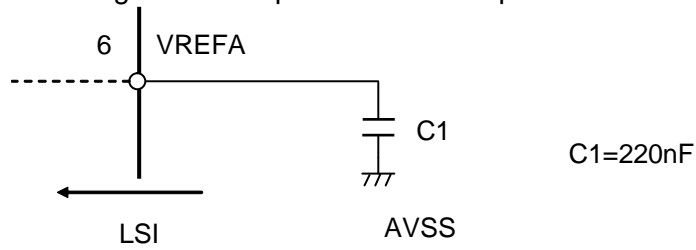

5) VREFD output

It is recommended that capacitors with 220nF or larger be connected between DVSS and VREFD pin to stabilize the VREFD signal. The capacitors must be placed as close to the pins as possible.

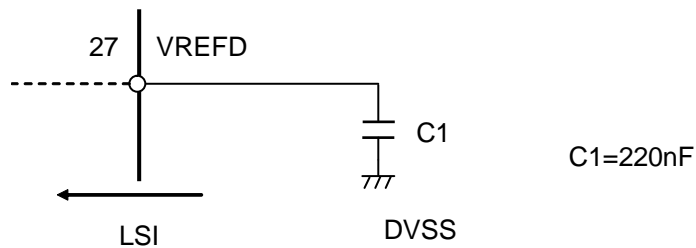

6) MIX

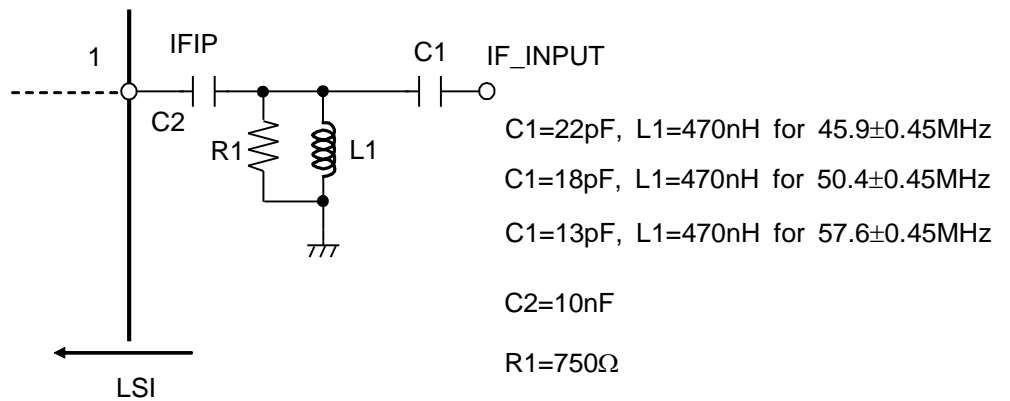

7) LOIN

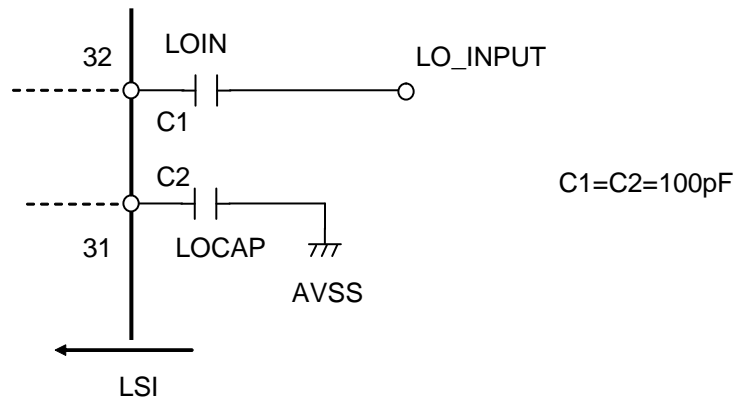

8) Discriminator

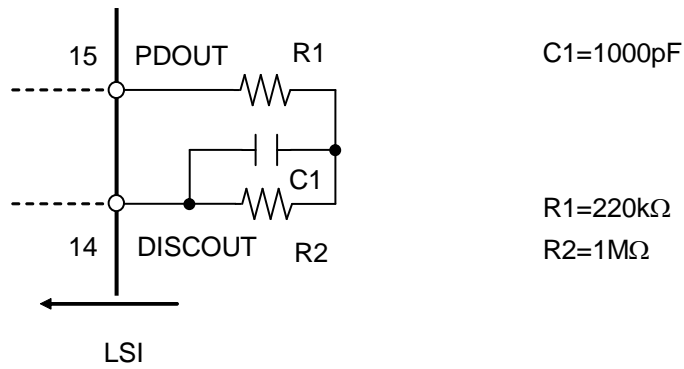

9) Noise AMP

The following gives a sample configuration of a BPF when input frequency is 31kHz. Some parameters can be calculated using following (1) to (3) equations.

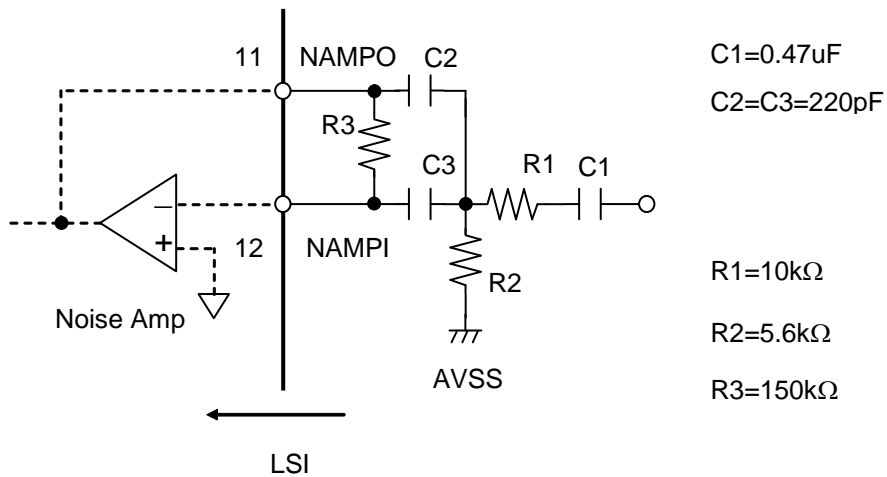

$$(1) f_0 = \frac{1}{2\pi\sqrt{R_3(R_1 // R_2)C_2C_3}}$$

$$(2) G_v = \frac{R_3}{2R_1}$$

$$(3) Q^2 = \frac{R_3}{4(R_1 // R_2)}$$

10) NECTO pin

Rise time of noise detection is proportionate to $C1=0.1\mu\text{F}$ and internal resistance $75\text{k}\Omega$

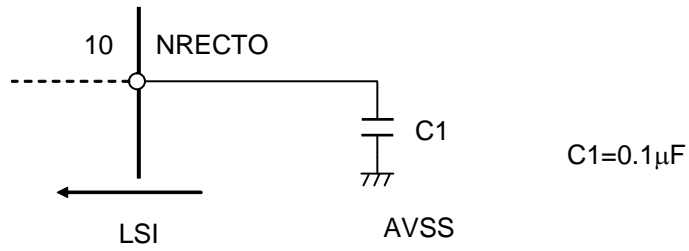

11) RSSIOUT pin

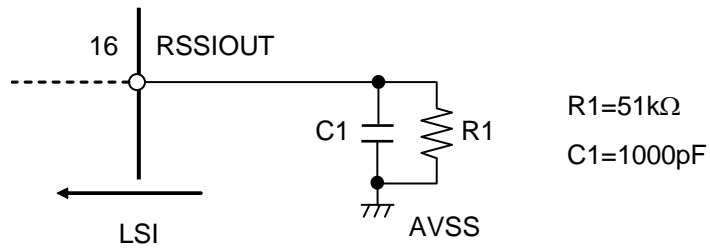

12) DETO

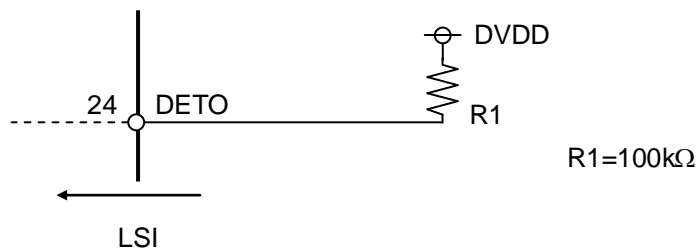

19. Packaging

Marking

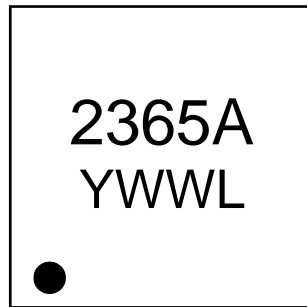

[Contents of YWWL]

Y: Last digit of calendar year. (Year 2011->1, 2012->2)

WW: Manufacturing week number.

L: Lot identification, given to each product lot which is made in a week.
 LOT ID is given in alphabetical order (A, B, C...).

Mechanical Outline

Package : 32pin QFN (4.0 x 4.0 x 0.7mm, 0.4mm pitch)

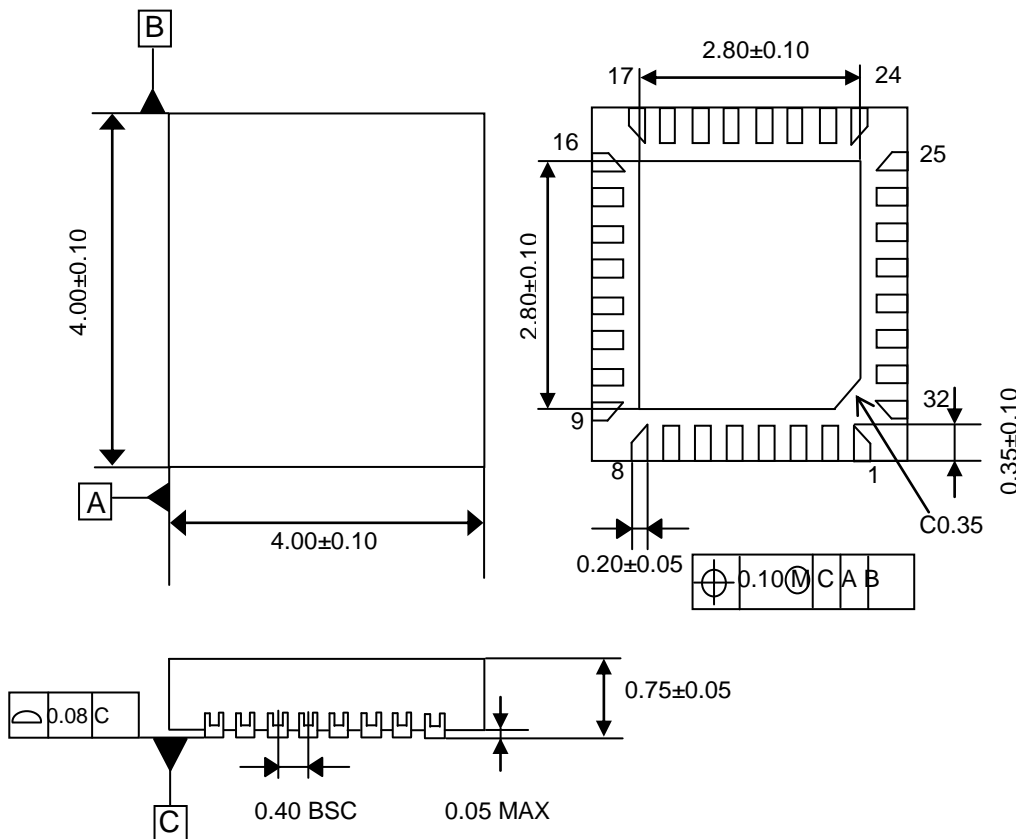

Note) The exposure pad(Exposed Pad) of the center of the package back is connected to opening or VSS.

IMPORTANT NOTICE

0. Asahi Kasei Microdevices Corporation ("AKM") reserves the right to make changes to the information contained in this document without notice. When you consider any use or application of AKM product stipulated in this document ("Product"), please make inquiries the sales office of AKM or authorized distributors as to current status of the Products.
1. All information included in this document are provided only to illustrate the operation and application examples of AKM Products. AKM neither makes warranties or representations with respect to the accuracy or completeness of the information contained in this document nor grants any license to any intellectual property rights or any other rights of AKM or any third party with respect to the information in this document. You are fully responsible for use of such information contained in this document in your product design or applications. **AKM ASSUMES NO LIABILITY FOR ANY LOSSES INCURRED BY YOU OR THIRD PARTIES ARISING FROM THE USE OF SUCH INFORMATION IN YOUR PRODUCT DESIGN OR APPLICATIONS.**
2. The Product is neither intended nor warranted for use in equipment or systems that require extraordinarily high levels of quality and/or reliability and/or a malfunction or failure of which may cause loss of human life, bodily injury, serious property damage or serious public impact, including but not limited to, equipment used in nuclear facilities, equipment used in the aerospace industry, medical equipment, equipment used for automobiles, trains, ships and other transportation, traffic signaling equipment, equipment used to control combustions or explosions, safety devices, elevators and escalators, devices related to electric power, and equipment used in finance-related fields. Do not use Product for the above use unless specifically agreed by AKM in writing.
3. Though AKM works continually to improve the Product's quality and reliability, you are responsible for complying with safety standards and for providing adequate designs and safeguards for your hardware, software and systems which minimize risk and avoid situations in which a malfunction or failure of the Product could cause loss of human life, bodily injury or damage to property, including data loss or corruption.
4. Do not use or otherwise make available the Product or related technology or any information contained in this document for any military purposes, including without limitation, for the design, development, use, stockpiling or manufacturing of nuclear, chemical, or biological weapons or missile technology products (mass destruction weapons). When exporting the Products or related technology or any information contained in this document, you should comply with the applicable export control laws and regulations and follow the procedures required by such laws and regulations. The Products and related technology may not be used for or incorporated into any products or systems whose manufacture, use, or sale is prohibited under any applicable domestic or foreign laws or regulations.
5. Please contact AKM sales representative for details as to environmental matters such as the RoHS compatibility of the Product. Please use the Product in compliance with all applicable laws and regulations that regulate the inclusion or use of controlled substances, including without limitation, the EU RoHS Directive. AKM assumes no liability for damages or losses occurring as a result of noncompliance with applicable laws and regulations.
6. Resale of the Product with provisions different from the statement and/or technical features set forth in this document shall immediately void any warranty granted by AKM for the Product and shall not create or extend in any manner whatsoever, any liability of AKM.
7. This document may not be reproduced or duplicated, in any form, in whole or in part, without prior written consent of AKM.

•Related Parts

Part#	Discription	Comments
Mixer		
AK1220	100MHz~900MHz High Linearity Down Conversion Mixer	IIP3:+22dBm
AK1222	100MHz~900MHz Low Power Down Conversion Mixer	IDD:2.9mA
AK1224	100MHz~900MHz Low Noise, High Liniarity Down Conversion Mixer	NF:8.5dB, IIP3:+18dBm
AK1228	10MHz~2GHz Up/Down Conversion Mixer	3V Supply, NF:8.5dB
AK1221	0.7GHz~3.5GHz High Linearity Down Conversion Mixer	IIP3:+25dBm
AK1223	3GHz~8.5GHz High Linearity Down Conversion Mixer	IIP3:+13dB, NF:15dB
PLL Synthesizer		
AK1541	20MHz~600MHz Low Power Fractional-N Synthesizer	IDD:4.6mA
AK1542A	20MHz~600MHz Low Power Integer-N Synthesizer	IDD:2.2mA
AK1543	400MHz~1.3GHz Low Power Fractional-N Synthesizer	IDD:5.1mA
AK1544	400MHz~1.3GHz Low Power Integer-N Synthesizer	IDD:2.8mA
AK1590	60MHz~1GHz Fractional-N Synthesizer	IDD:2.5mA
AK1545	0.5GHz~3.5GHz Integer-N Synthesizer	16-TSSOP
AK1546	0.5GHz~3GHz Low Phase Noise Integer-N Synthesizer	Normalized C/N:-226dBc/Hz
AK1547	0.5GHz~4GHz Integer-N Synthesizer	5V Supply
AK1548	1GHz~8GHz Low Phase Noise Integer-N Synthesizer	Normalized C/N:-226dBc/Hz
IFVGA		
AK1291	100~300MHz Analog Signal Control IF VGA w/ RSSI	Dynamic Range:30dB
integrated VCO		
AK1572	690MHz~4GHz Down Conversion Mixer with Frac.-N PLL and VCO	IIP3:24dBm, -111dBc/Hz@100kHz
AK1575	690MHz~4GHz Up Conversion Mixer with Frac.-N PLL and VCO	IIP3:24dBm, -111dBc/Hz@100kHz
IF Reciever (2nd Mixer + IF BPF + FM Detector)		
AK2364	Built-in programmable AGC+BPF, FM detector IC	IFBPF:±10kHz ~ ±4.5kHz
AK2365A	Built-in programmable AGC+BPF, IFIC	IFBPF:±7.5kHz ~ ±2kHz
Analog BB for PMR/LMR		
AK2345C	CTCSS Filter, Encoder, Decoder	24-VSOP
AK2360/ AK2360A	Inverted frequency(3.376kHz/3.020kHz) scrambler	8-SON
AK2363	MSK Modem/DTMF Receiver	24-QFN
AK2346B	0.3-2.55/3.0kHz Analog audio filter,	24-VSOP
AK2346A	Emphasis, Compandor, scrambler, MSK Modem	24-QFN
AK2347B	0.3-2.55/3.0kHz Analog audio filter Emphasis, Compandor, scrambler, CTCSS filter	24-VSOP
Function IC		
AK2330	8-bit 8ch Electronic Volume	VREF can be selected for each channel
AK2331	8-bit 4ch Electronic Volume	VREF can be selected for each channel

Asahi Kasei Microdevices Corporation ("AKM") reserves the right to make changes to the information contained in this document without notice. When you consider any use or application of AKM product stipulated in this document, please make inquiries the sales office of AKM or authorized distributors as to current status of the Products.