

SKY73078-459LF: 500-1500 MHz Quadrature Modulator

Applications

- Cellular base station systems: GSM/EDGE, CDMA2000, W-CDMA, TD-SCDMA, LTE
- WiMAX/broadband wireless access systems
- Satellite modems

Features

- RF frequency operation range: 500 to 1500 MHz
- Modulation bandwidth > 65 MHz (0.1 dB), 210 MHz (1 dB)
- Side-band suppression better than -45 dBc
- Carrier feedthrough of -40 dBm
- Noise floor of -158 dBm/Hz
- Single supply: 4.75 to 5.25 V
- QFN (24-pin, 4 x 4 mm) package (MSL1, 260 °C per JEDEC J-STD-020)



Skyworks Pb-free products are compliant with all applicable legislation. For additional information, refer to *Skyworks Definition of Lead (Pb)-Free*, document number SQ04-0073.

Description

Skyworks SKY73078-459LF is an integrated quadrature modulator for the upconversion of complex modulated baseband/IF signals directly up to RF. The device is designed for use in the 500 to 1500 MHz range. The high linearity, and excellent I/Q phase accuracy and amplitude balance of the SKY73078-459LF make it ideal for use in high performance communication systems.

The modulator accepts two differential baseband inputs and a single-ended Local Oscillator (LO), and generates a single-ended RF output. The baseband input buffers accept an input common-mode voltage of 0.5 V and have a 0.1 dB bandwidth of >65 MHz. The LO input is broadband matched on-chip to 50 Ω, which enables a direct connection to a 50 Ω LO source. The RF output is high impedance, designed for a direct connection to a 50 Ω load.

Figure 1 shows a functional block diagram for the SKY73078-459LF. The device package and pinout for the 24-pin Quad Flat No-Lead (QFN) package are shown in Figure 2. Signal pin assignments and functional pin descriptions are provided in Table 1.

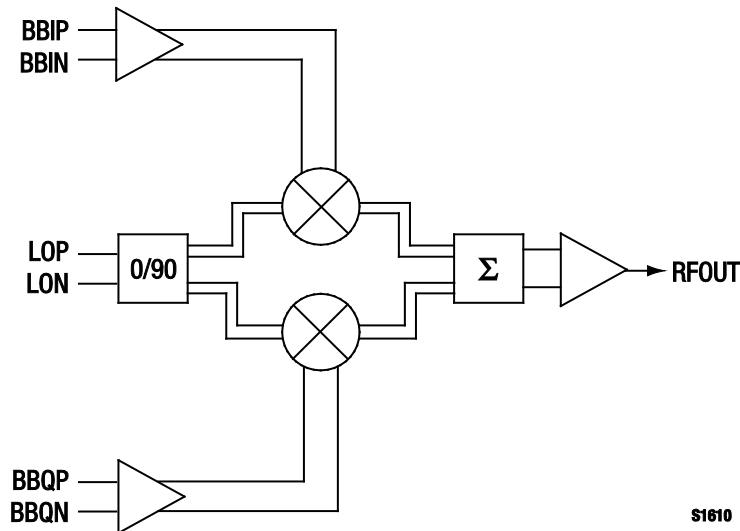

S1610

Figure 1. SKY73078-459LF Functional Block Diagram

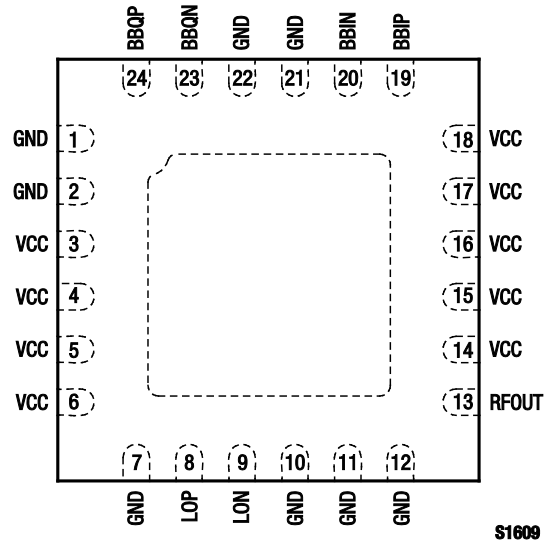

Figure 2. SKY73078-459LF Pinout, 24-Pin QFN (Top View)

Table 1. SKY73078-459LF Signal Descriptions

Pin #	Name	Description	Pin #	Name	Description
1	GND	Ground	13	RFOUT	RF output. Pin should be AC-coupled to the load.
2	GND	Ground	14	VCC	+5 VDC supply
3	VCC	+5 VDC supply	15	VCC	+5 VDC supply
4	VCC	+5 VDC supply	16	VCC	+5 VDC supply
5	VCC	+5 VDC supply	17	VCC	+5 VDC supply
6	VCC	+5 VDC supply	18	VCC	+5 VDC supply
7	GND	Ground	19	BBIP	High impedance positive I input. Should be externally DC-biased to 0.5 V.
8	LOP	50 Ω single-ended positive LO input. Pin must be AC-coupled to the LO.	20	BBIN	High impedance negative I input. Should be externally DC-biased to 0.5 V.
9	LON	50 Ω single-ended negative LO input. Pin must be AC-coupled to ground.	21	GND	Ground
10	GND	Ground	22	GND	Ground
11	GND	Ground	23	BBQP	High impedance positive Q input. Should be externally DC-biased to 0.5 V.
12	GND	Ground	24	BBQN	High impedance negative Q input. Should be externally DC-biased to 0.5 V.

Technical Description

The SKY73078-459LF is comprised of four main functional areas: the LO chain, the baseband input level shifters, the mixers, and the differential to single-ended converter.

LO Chain

The LO chain consists of an input linear buffer, a polyphase quadrature phase splitter, and limiting amplifiers. The input buffer provides an internal 50 Ω match while generating an amplified differential signal to the polyphase splitters.

The LO can be driven either single-ended or differentially. For single-ended LO signals, the LON signal (pin 9) should be AC-grounded using a capacitor. Each quadrature LO signal is passed through limiting amplifiers before driving the mixers.

Baseband Input Level Shifters

The baseband inputs present a high input impedance while providing proper DC levels for the mixer inputs. The recommended DC voltage for the baseband common-mode voltage is 500 mV.

Mixers

The SKY73078-459LF incorporates two Gilbert-type, double-balanced mixers for both the In-Phase (I) and Quadrature (Q) channels. The differential output currents are summed together into an on-chip passive balun, which converts the differential signal to a single-ended output.

Differential to Single-Ended Converter

The differential to single-ended converter is an on-chip passive balun that converts the differential mixer output signal to a single-ended signal. The high impedance output of the balun is designed to interface directly to a 50 Ω load. If desired, an external matching network could be used for power matching between the balun and the 50 Ω load.

Electrical and Mechanical Specifications

The absolute maximum ratings of the SKY73078-459LF are provided in Table 2. The recommended operating conditions are specified in Table 3 and electrical specifications are provided in Tables 4, 5, and 6.

Table 2. SKY73078-459LF Absolute Maximum Ratings

Parameter	Symbol	Minimum	Typical	Maximum	Units
Supply voltage, +5 V	VCC	4.75		5.50	V
Supply current	I _{CC}			218	mA
LO input power	P _{LO}			+6	dBm
Operating temperature	T _C	-40		+85	°C
Junction temperature	T _J			+150	°C
Storage temperature	T _{STG}	-40		+125	°C

Notes: Exposure to maximum rating conditions for extended periods may reduce device reliability. There is no damage to device with only one parameter set at the limit and all other parameters set at or below their nominal value. Exceeding any of the limits listed here may result in permanent damage to the device.

Nominal thermal resistance (junction to case) is 5.1 °C/W.

CAUTION: Although this device is designed to be as robust as possible, Electrostatic Discharge (ESD) can damage this device. This device must be protected at all times from ESD. Static charges may easily produce potentials of several kilovolts on the human body or equipment, which can discharge without detection. Industry-standard ESD precautions should be used at all times. The SKY73078-459LF ESD threshold level is 2500 VDC using Human Body Model (HBM) testing. This level applies to RF signal lines >100 MHz, analog and RF lines <100 MHz, digital lines, power supply lines, and ground pins.

Table 3. SKY73078-459LF Recommended Operating Conditions

Parameter	Symbol	Minimum	Typical	Maximum	Units
Supply voltage, +5 V	V _{CC}	4.75	5.00	5.25	V
Supply current	I _{CC}		147		mA
RF frequency	V _{RF}	500		1500	MHz
Baseband input frequency	F _{BB}	0		200	MHz
LO input power	P _{LO}	-6	0	+6	dBm
LO frequency range	F _{LO}	500		1500	MHz
Operating case temperature	T _C	-40		+85	°C

Table 4. SKY73078-459LF Electrical Characteristics: RF Output (Note 1)

(V_{CC} = 5 V, T_A = 25 °C, LO Amplitude = 0 dBm, I/Q Amplitude = 1.4 V_{pp} differential, V_{CM} = 0.5 V, F_{BB} = 1 MHz, Unless Otherwise Noted)

Parameter	Symbol	Test Conditions	Min	Typ	Max	Units
GSM850 and EGSM900, F_{RF} = 869 MHz to 960 MHz						
RF output power (Note 2)	P _{OUT}			+6		dBm
1 dB Output Compression Point	OP1dB			+10.5		dBm
Carrier feedthrough				-43		dBm
Sideband suppression				-48		dBc
2nd harmonic (harmonic of baseband input)	2fo	P _{OUT} = +7.5 dBm, harmonic output @ F _{LO} ± 2F _{BB}		-63		dBc
3rd harmonic (harmonic of baseband input)	3fo	P _{OUT} = +7.5 dBm, harmonic output @ F _{LO} ± 3F _{BB}		-49		dBc
3rd Order Output Intercept Point	OIP3			+27		dBm
Noise floor: without I/Q inputs		@ 20 MHz, I/Q = 0 V _{DIFF}		-158.6		dBm/Hz
with I/Q inputs		@ 6 MHz, P _{OUT} = +5 dBm		-153.5		dBm/Hz
Output return loss				TBD		dB
LTE Bands XII and XIII, F_{RF} = 728 MHz to 756 MHz						
RF output power (Note 3)	P _{OUT}			+4		dBm
1 dB Output Compression Point	OP1dB			+8		dBm
Carrier feedthrough				-45		dBm
Sideband suppression				-57		dBc
2nd harmonic (harmonic of baseband input)	2fo	P _{OUT} = +4 dBm, harmonic output @ F _{LO} ± 2F _{bb}		-68		dBc
3rd harmonic (harmonic of baseband input)	3fo	P _{OUT} = +4 dBm, harmonic output @ F _{LO} ± 3F _{bb}		-49		dBc
3rd Order Output Intercept Point	OIP3			+25		dBm
Noise floor: without I/Q inputs		@ 20 MHz, I/Q = 0 V _{DIFF}		-160.5		dBm/Hz
with I/Q inputs		@ 6 MHz, P _{OUT} = +4 dBm		-152.0		dBm/Hz
Output return loss				TBD		dB

Note 1: Performance is guaranteed only under the conditions listed in this Table.

Note 2: While the device is specified to achieve +7.5 dBm RF output with sinusoidal baseband inputs, typical RF output power for normal GMSK operation is +4 dBm (single carrier power) or -9.5 dBm (multicarrier total power).

Note 3: While the device is specified to achieve +4 dBm RF output with sinusoidal baseband inputs, typical RF output power for normal LTE operation is TBD dBm total power.

Table 5. SKY73078-459LF Electrical Characteristics: LO Input (Note 1)
(V_{CC} = 5 V, T_A = 25 °C, Unless Otherwise Noted)

Parameter	Symbol	Test Conditions	Min	Typ	Max	Units
<i>GSM850 and EGSM900, F_{RF} = 869 MHz to 960 MHz</i>						
LO drive level		Single-ended	-6	0	+6	dBm
LO port return loss		50 Ω single-ended		20		dB
LO frequency (Note 2)		EGSM900 high side LO	925.2		1159.8	MHz
		GSM850 high side LO	869.2		1093.8	MHz
		EGSM900 low side LO	725.2		959.8	MHz
		GSM850 low side LO	669.2		893.8	MHz
<i>LTE Bands XII and XIII, F_{RF} = 728 MHz to 756 MHz</i>						
LO drive level		Single-ended	-6	0	+6	dBm
LO port return loss		50 Ω single-ended		20		dB
LO frequency (Note 3)		Band XIII high side LO	746		956	MHz
		Band XII high side LO	728		946	MHz
		Band XIII low side LO	546		756	MHz
		Band XII low side LO	528		746	MHz

Note 1: Performance is guaranteed only under the conditions listed in this Table.

Note 2: Covers single and multi-carrier operation for GSM850 and EGSM900 bands.

Note 3: Covers single and multi-carrier operation for bands XII and XIII.

Table 6. SKY73078-459LF Electrical Characteristics: Baseband Input (Note 1)
(V_{CC} = 5 V, T_A = 25 °C, Unless Otherwise Noted)

Parameter	Symbol	Test Conditions	Min	Typ	Max	Units
Baseband input DC bias common mode voltage	V _{CM}			0.5		V
I/Q input amplitude		PP differential, sinusoidal RMS single-ended		1.4		V
Differential input resistance				5.9		kΩ
Differential input capacitance		Parallel		TBD		pF
I/Q input bandwidth (0.1 dB) (Note 2)				70		MHz

Note 1: Performance is guaranteed only under the conditions listed in this Table.

Note 2: Assuming a 50 Ω source.

Evaluation Board Description

The SKY73078-459LF Evaluation Board is used to test the performance of the SKY73078-459LF quadrature modulator. An assembly drawing for the Evaluation Board is shown in Figure 3 and the layer detail is provided in Figure 4. An Evaluation Board schematic diagram is provided in Figure 5.

Circuit Design Configurations

The following design considerations are critical and must be followed regardless of final use or configuration:

- Component C106 is an AC ground and should be placed as close as possible to pin 9 (LON) of the device.
- Components C111 and C121 are bypass capacitors and should be placed as close as possible to one of the V_{CC} pins, 14 through 18.

- Components C104 and C125 are bypass capacitors and should be placed as close as possible to one of the V_{CC} pins, 3 through 6.

Package Dimensions

Package dimensions for the 24-pin QFN are shown in Figure 6, and tape and reel dimensions are provided in Figure 7.

Package and Handling Information

Instructions on the shipping container label regarding exposure to moisture after the container seal is broken must be followed. Otherwise, problems related to moisture absorption may occur when the part is subjected to high temperature during solder assembly.

DATA SHEET • SKY73078-459LF QUADRATURE MODULATOR

The SKY73078-459LF is rated to Moisture Sensitivity Level 1 (MSL1) at 260 °C. It can be used for lead or lead-free soldering. For additional information, refer to the Skyworks Application Note, *Solder Reflow Information*, document number 200164.

Care must be taken when attaching this product, whether it is done manually or in a production solder reflow environment. Production quantities of this product are shipped in a standard tape and reel format.

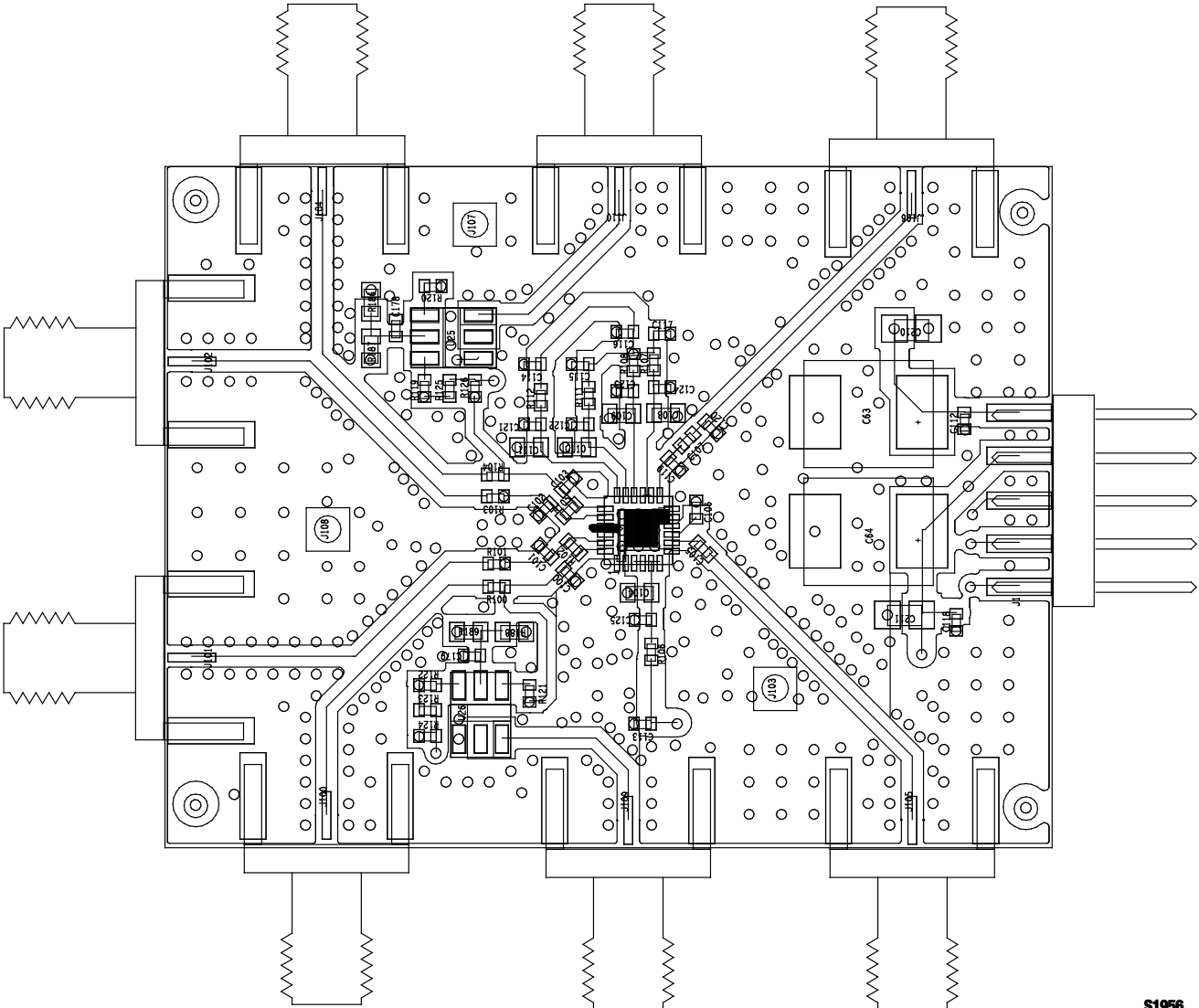

S1956

Figure 3. SKY73078-459LF Evaluation Board Assembly Diagram

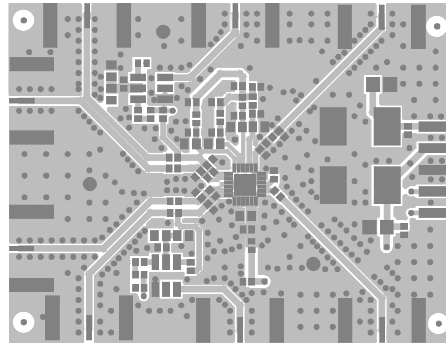

Layer 1: Top – Metal

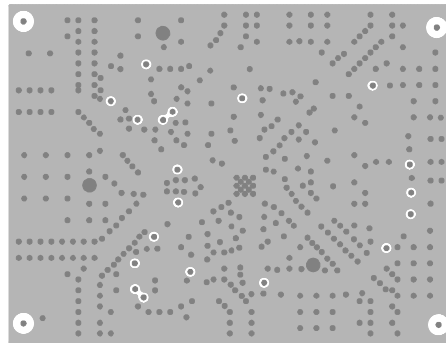

Layer 2: Ground

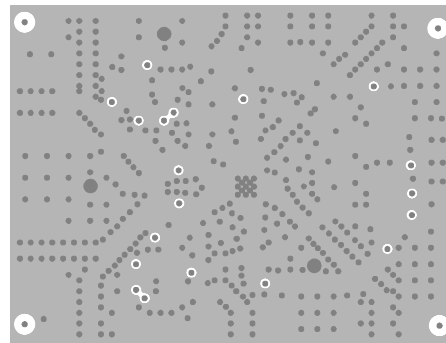

Layer 3: Power Plane

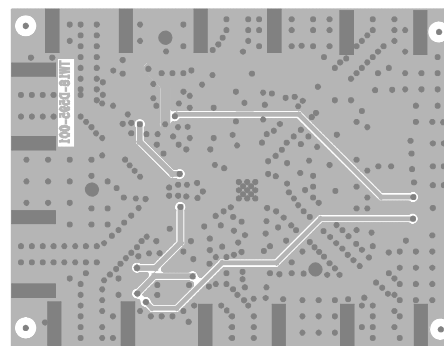

Layer 4: Solid Ground Plane

S1955

Figure 4. SKY73078-459LF Evaluation Board Layer Detail

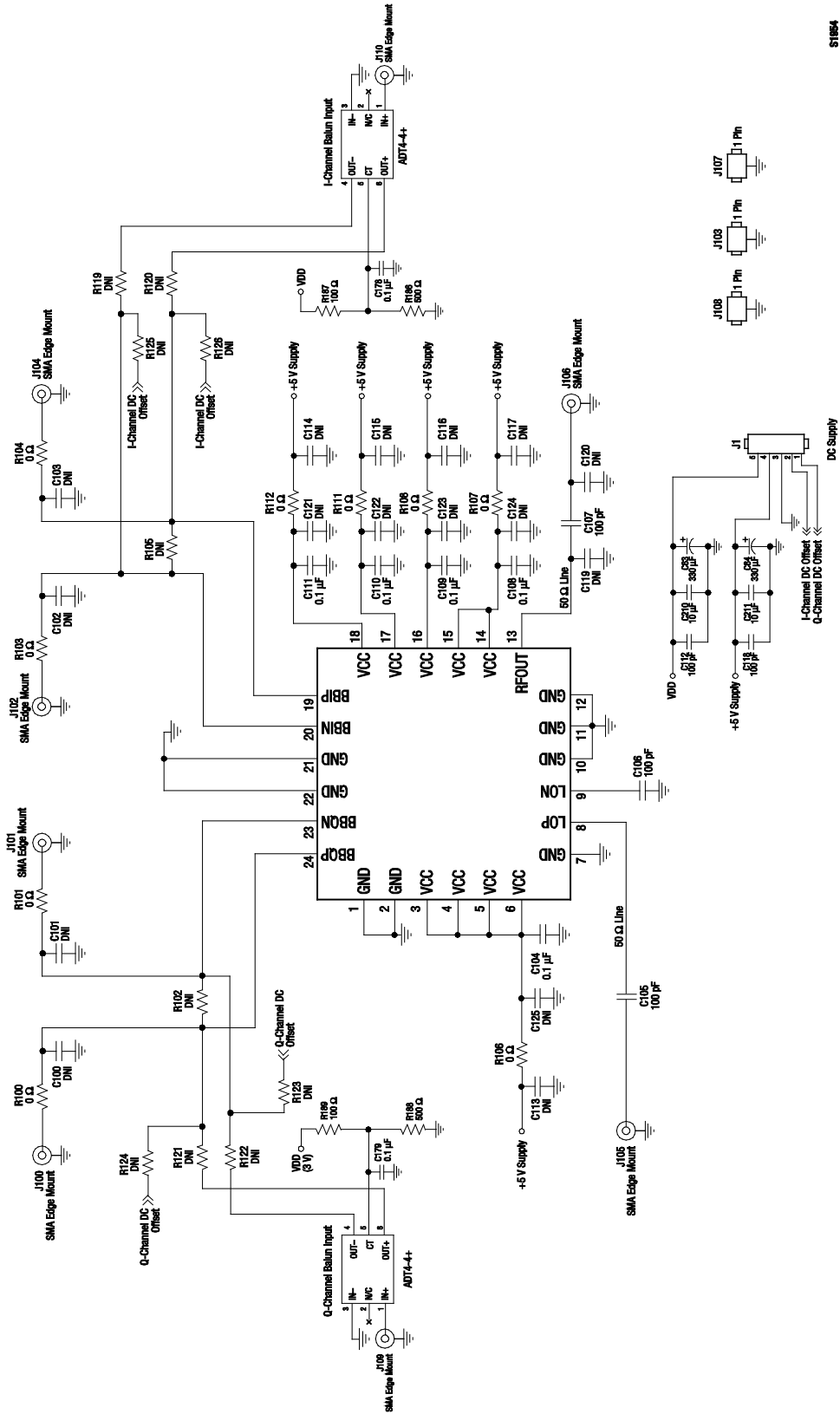
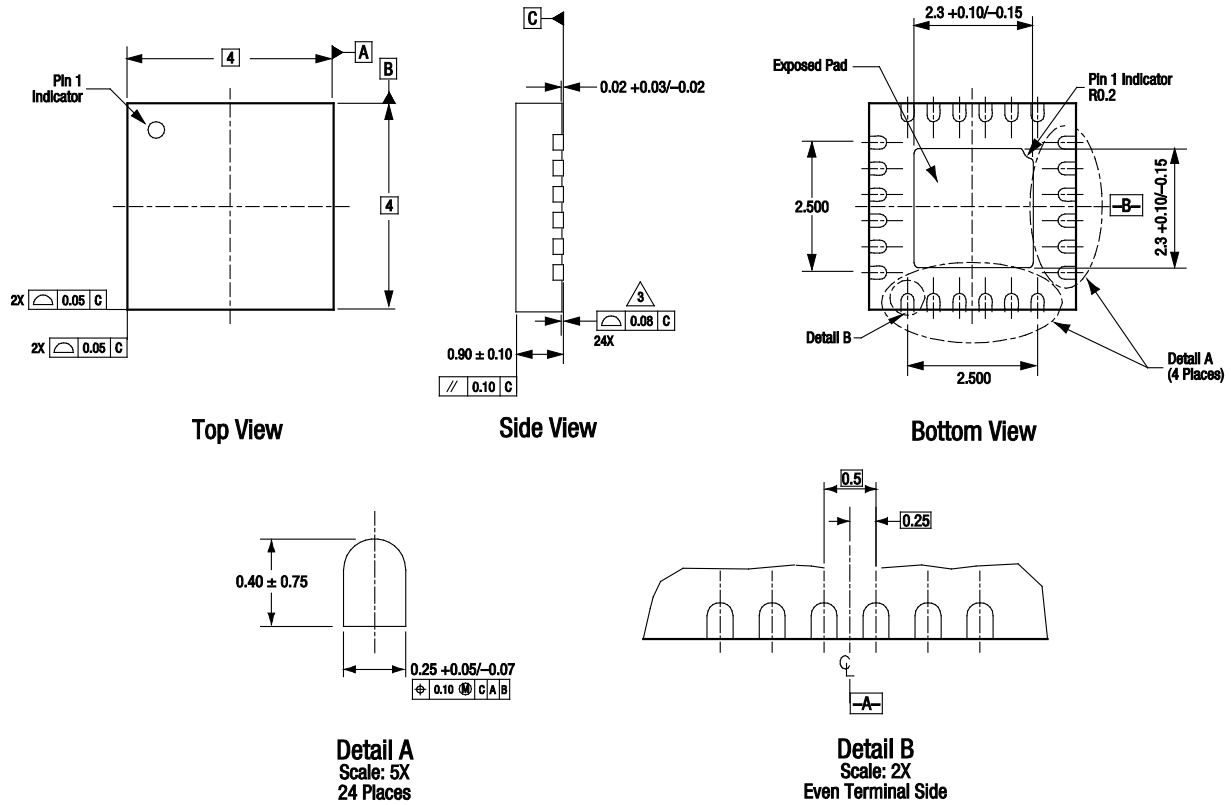

Figure 5. SKY73078-459LF Application Schematic



All measurements are in millimeters.
Dimensioning and tolerancing according to ASME Y14.5M-1994.
Coplanarity applies to the exposed heat sink slug as well as the terminals.

S1054a

Figure 6. SKY73078-459LF 24-Pin QFN Package Dimensions

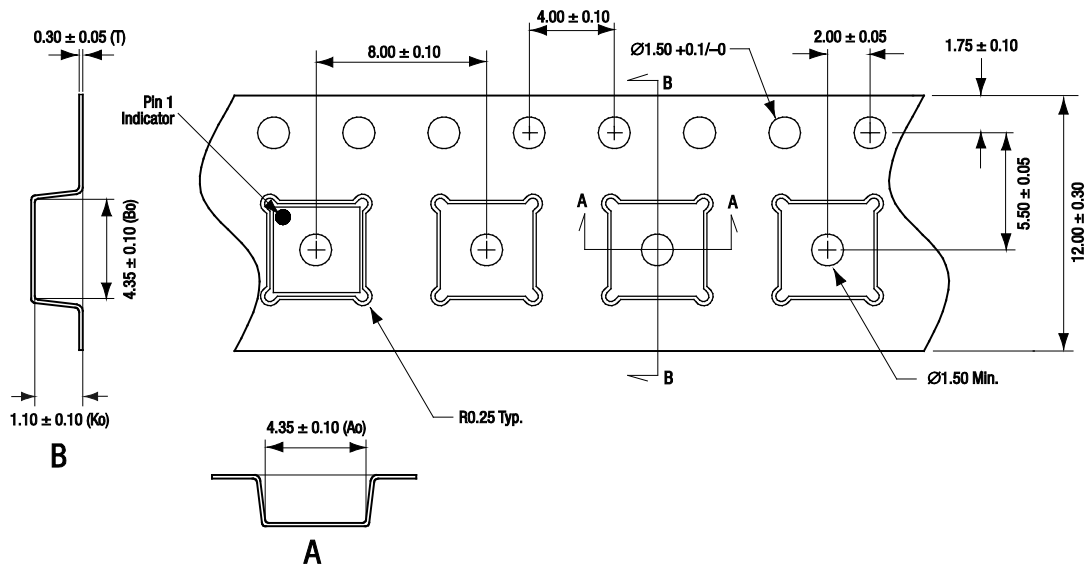

S1846

Figure 7. SKY73078-459LF Tape and Reel Dimensions

Ordering Information

Model Name	Manufacturing Part Number	Evaluation Board Part Number
SKY73078-459LF 500-1500 MHz Quadrature Modulator	SKY73078-459LF	TW18-D562-001

Copyright © 2009, 2010, 2011 Skyworks Solutions, Inc. All Rights Reserved.

Information in this document is provided in connection with Skyworks Solutions, Inc. ("Skyworks") products or services. These materials, including the information contained herein, are provided by Skyworks as a service to its customers and may be used for informational purposes only by the customer. Skyworks assumes no responsibility for errors or omissions in these materials or the information contained herein. Skyworks may change its documentation, products, services, specifications or product descriptions at any time, without notice. Skyworks makes no commitment to update the materials or information and shall have no responsibility whatsoever for conflicts, incompatibilities, or other difficulties arising from any future changes.

No license, whether express, implied, by estoppel or otherwise, is granted to any intellectual property rights by this document. Skyworks assumes no liability for any materials, products or information provided hereunder, including the sale, distribution, reproduction or use of Skyworks products, information or materials, except as may be provided in Skyworks Terms and Conditions of Sale.

THE MATERIALS, PRODUCTS AND INFORMATION ARE PROVIDED "AS IS" WITHOUT WARRANTY OF ANY KIND, WHETHER EXPRESS, IMPLIED, STATUTORY, OR OTHERWISE, INCLUDING FITNESS FOR A PARTICULAR PURPOSE OR USE, MERCHANTABILITY, PERFORMANCE, QUALITY OR NON-INFRINGEMENT OF ANY INTELLECTUAL PROPERTY RIGHT; ALL SUCH WARRANTIES ARE HEREBY EXPRESSLY DISCLAIMED. SKYWORKS DOES NOT WARRANT THE ACCURACY OR COMPLETENESS OF THE INFORMATION, TEXT, GRAPHICS OR OTHER ITEMS CONTAINED WITHIN THESE MATERIALS. SKYWORKS SHALL NOT BE LIABLE FOR ANY DAMAGES, INCLUDING BUT NOT LIMITED TO ANY SPECIAL, INDIRECT, INCIDENTAL, STATUTORY, OR CONSEQUENTIAL DAMAGES, INCLUDING WITHOUT LIMITATION, LOST REVENUES OR LOST PROFITS THAT MAY RESULT FROM THE USE OF THE MATERIALS OR INFORMATION, WHETHER OR NOT THE RECIPIENT OF MATERIALS HAS BEEN ADVISED OF THE POSSIBILITY OF SUCH DAMAGE.

Skyworks products are not intended for use in medical, lifesaving or life-sustaining applications, or other equipment in which the failure of the Skyworks products could lead to personal injury, death, physical or environmental damage. Skyworks customers using or selling Skyworks products for use in such applications do so at their own risk and agree to fully indemnify Skyworks for any damages resulting from such improper use or sale.

Customers are responsible for their products and applications using Skyworks products, which may deviate from published specifications as a result of design defects, errors, or operation of products outside of published parameters or design specifications. Customers should include design and operating safeguards to minimize these and other risks. Skyworks assumes no liability for applications assistance, customer product design, or damage to any equipment resulting from the use of Skyworks products outside of stated published specifications or parameters.

Skyworks, the Skyworks symbol, and "Breakthrough Simplicity" are trademarks or registered trademarks of Skyworks Solutions, Inc., in the United States and other countries. Third-party brands and names are for identification purposes only, and are the property of their respective owners. Additional information, including relevant terms and conditions, posted at www.skyworksinc.com, are incorporated by reference.