



STPS30L45CG/CR/CT/CW/CFP

LOW DROP POWER SCHOTTKY RECTIFIER

MAIN PRODUCTS CHARACTERISTICS

$I_{F(AV)}$	2 x 15 A
V_{RRM}	45 V
$T_j(\text{max})$	150 °C
$V_F(\text{max})$	0.50 V

FEATURES AND BENEFITS

- Low forward voltage drop meaning very small conduction losses
- Low switching losses allowing high frequency operation
- Low thermal resistance
- Avalanche rated
- Insulated package: TO-220FPAB
Insulating voltage: 2000V DC
Capacitance = 45pF

DESCRIPTION

Dual center tap schottky rectifiers suited for Switched Mode Power Supplies and high frequency DC to DC converters.

Packaged in TO-247, TO-220AB, TO-220FPAB, D²PAK and I²PAK these devices are intended for use in low voltage, high frequency inverters, free-wheeling and polarity protection applications.

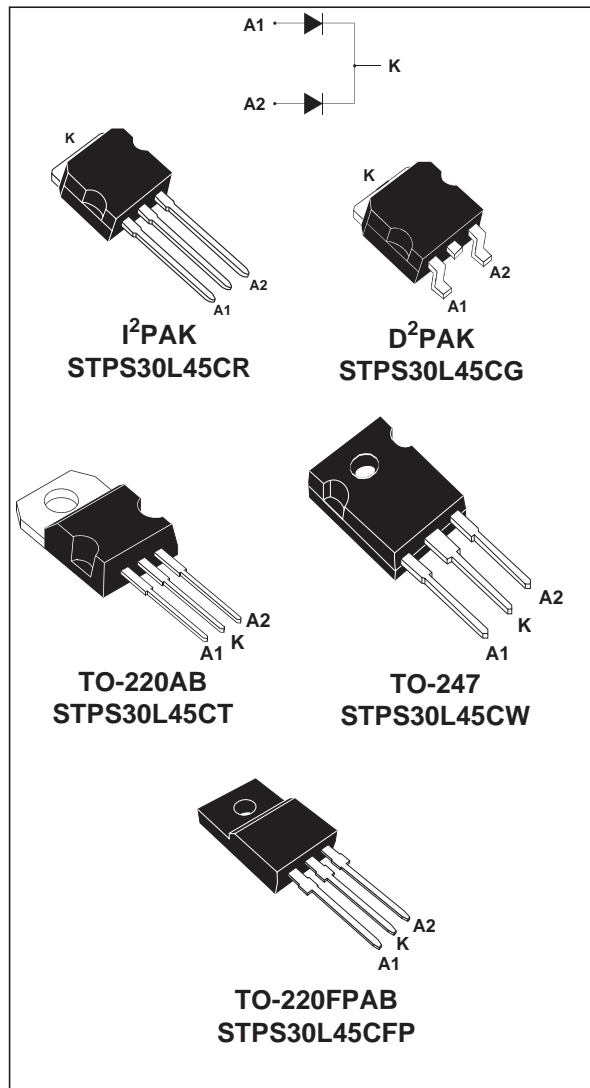

STPS30L45CG/CR/CT/CW/CFP

ABSOLUTE RATINGS (limiting values, per diode)

Symbol	Parameter			Value	Unit	
V _{RRM}	Repetitive peak reverse voltage			45	V	
I _{F(RMS)}	RMS forward current			30	A	
I _{F(AV)}	Average forward current	TO-220FPAB	T _c = 110°C δ = 0.5	Per diode Per device	15 30	A
		TO-220AB, TO-247, I ² PAK, D ² PAK	T _c = 135°C δ = 0.5			
I _{FSM}	Surge non repetitive forward current		tp = 10 ms Sinusoidal	220	A	
I _{RRM}	Repetitive peak reverse current		tp=2 μs square F=1kHz	1	A	
I _{RSM}	Non repetitive peak reverse current		tp = 100 μs square	3	A	
T _{stg}	Storage temperature range			- 65 to + 150	°C	
T _j	Maximum operating junction temperature *			150	°C	
dV/dt	Critical rate of rise of reverse voltage			10000	V/μs	

* : $\frac{dP_{tot}}{dT_j} < \frac{1}{R_{th(j-a)}}$ thermal runaway condition for a diode on its own heatsink

THERMAL RESISTANCES

Symbol	Parameter			Value	Unit
R _{th(j-c)}	Junction to case	TO-220FPAB	Per diode Total	4 3.2	°C/W
		TO-220AB, TO-247, I ² PAK, D ² PAK	Per diode Total	1.60 0.85	
R _{th(c)}		TO-220FPAB	Coupling	2.5	°C/W
		TO-220AB, TO-247, I ² PAK, D ² PAK		0.10	

When the diodes 1 and 2 are used simultaneously :

$$\Delta T_j(\text{diode 1}) = P(\text{diode 1}) \times R_{th(j-c)}(\text{Per diode}) + P(\text{diode 2}) \times R_{th(c)}$$

STATIC ELECTRICAL CHARACTERISTICS (per diode)

Symbol	Parameter	Tests Conditions		Min.	Typ.	Max.	Unit
I _R *	Reverse leakage current	T _j = 25°C	V _R = V _{RRM}			0.4	mA
		T _j = 125°C			100	200	mA
V _F *	Forward voltage drop	T _j = 25°C	I _F = 15 A			0.55	V
		T _j = 125°C	I _F = 15 A		0.42	0.50	
		T _j = 25°C	I _F = 30 A			0.74	
		T _j = 125°C	I _F = 30 A		0.59	0.67	

Pulse test : * tp = 380 μs, δ < 2%

To evaluate the conduction losses use the following equation :

$$P = 0.330 \times I_{F(AV)} + 0.011 I_{F(RMS)}^2$$

Fig. 1: Average forward power dissipation versus average forward current (per diode).

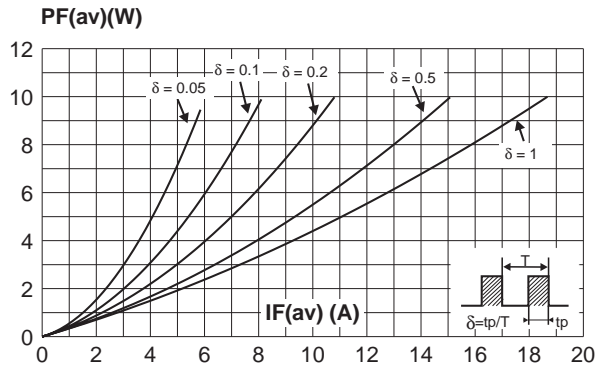

Fig. 2: Average forward current versus ambient temperature ($\delta=0.5$, per diode).

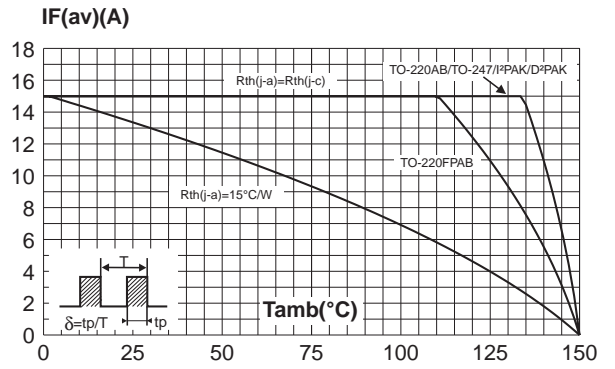

Fig. 3-1: Non repetitive surge peak forward current versus overload duration (maximum values, per diode).

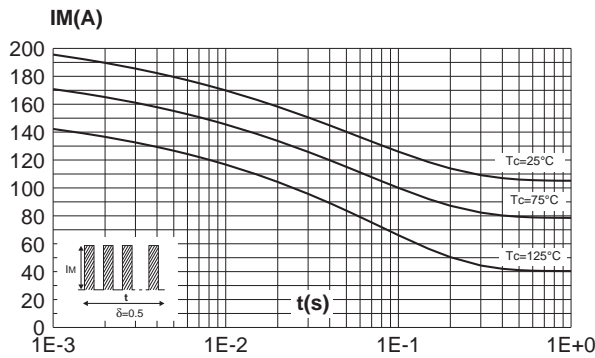

Fig. 3-2: Non repetitive surge peak forward current versus overload duration (maximum values, per diode) (TO-220FPAB only).

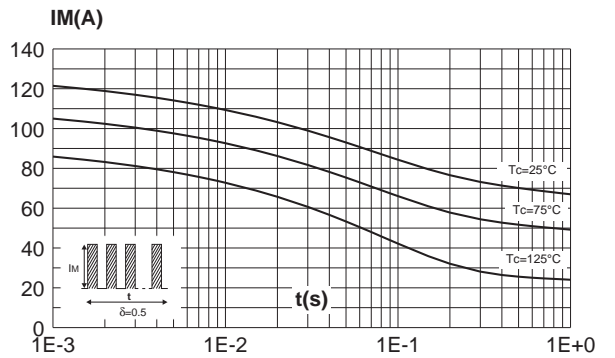

Fig. 4-1: Relative variation of thermal impedance junction to case versus pulse duration.

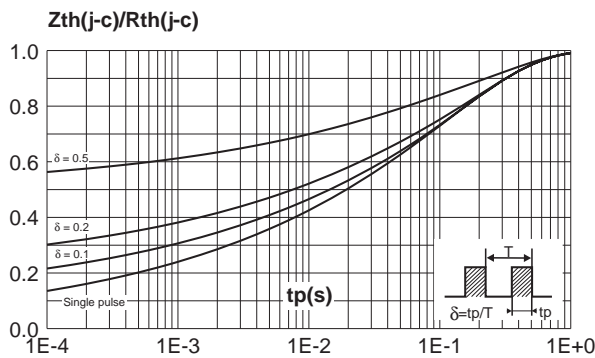

Fig. 4-2: Relative variation of thermal impedance junction to case versus pulse duration. (TO-220FPAB)

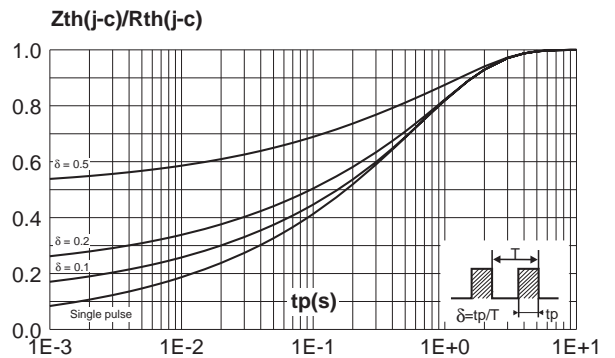

Fig. 5: Reverse leakage current versus reverse voltage applied (typical values, per diode).

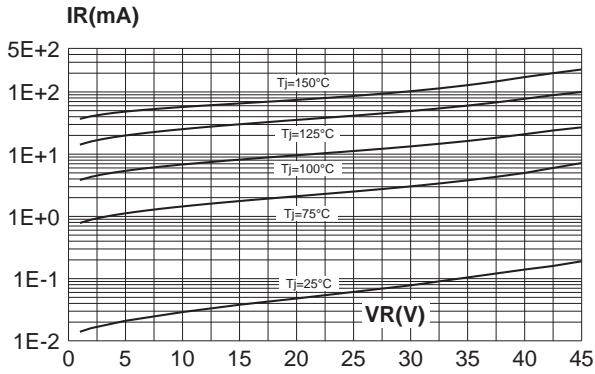

Fig. 6: Junction capacitance versus reverse voltage applied (typical values, per diode).

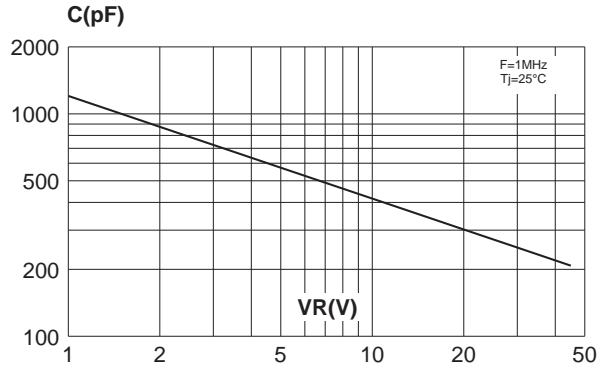

Fig. 7: Forward voltage drop versus forward current (maximum values, per diode).

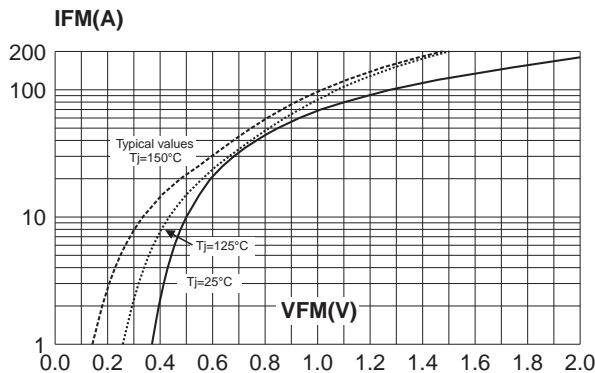
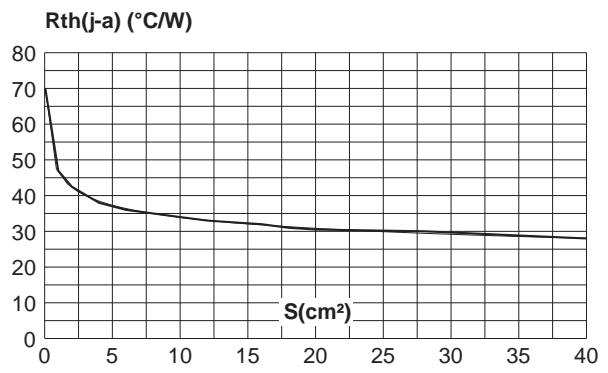
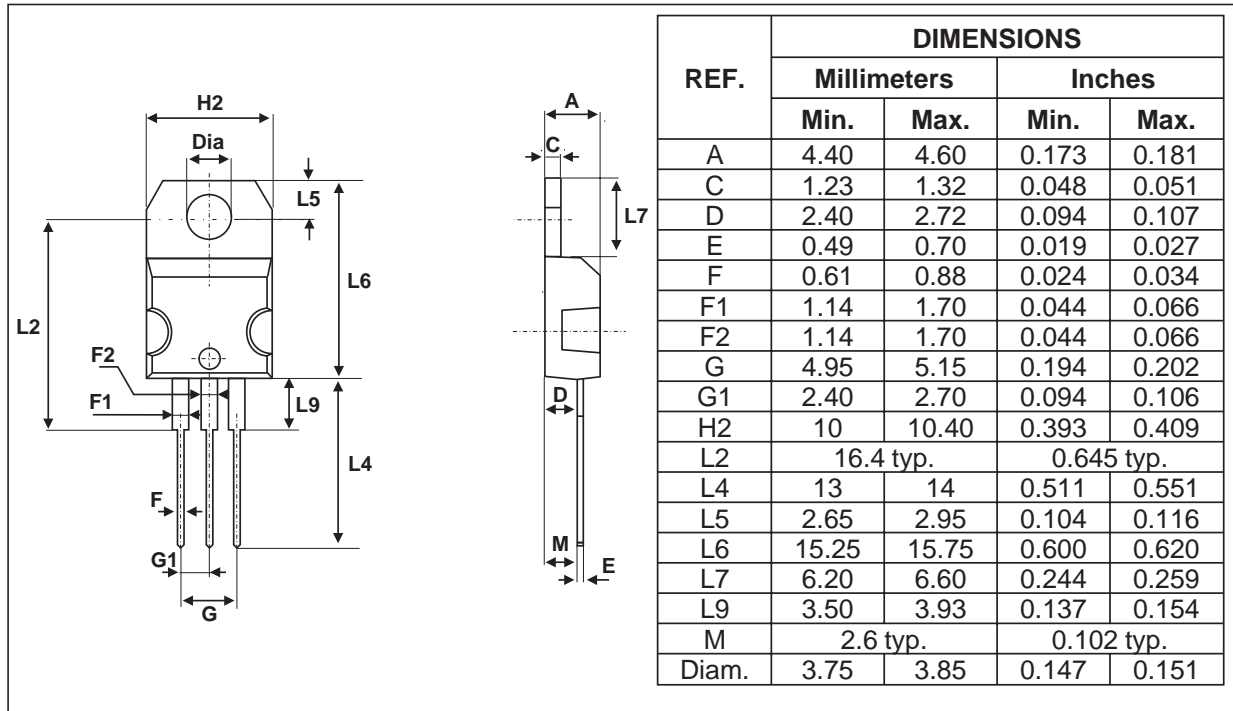

Fig. 8: Thermal resistance junction to ambient versus copper surface under tab for D²PAK (Epoxy printed circuit board FR4, copper thickness: 35µm).



PACKAGE MECHANICAL DATA
TO-220AB



- Cooling method : C
- Recommended torque value : 0.55 m.N
- Maximum torque value : 0.70 m.N

PACKAGE MECHANICAL DATA
I²PAK

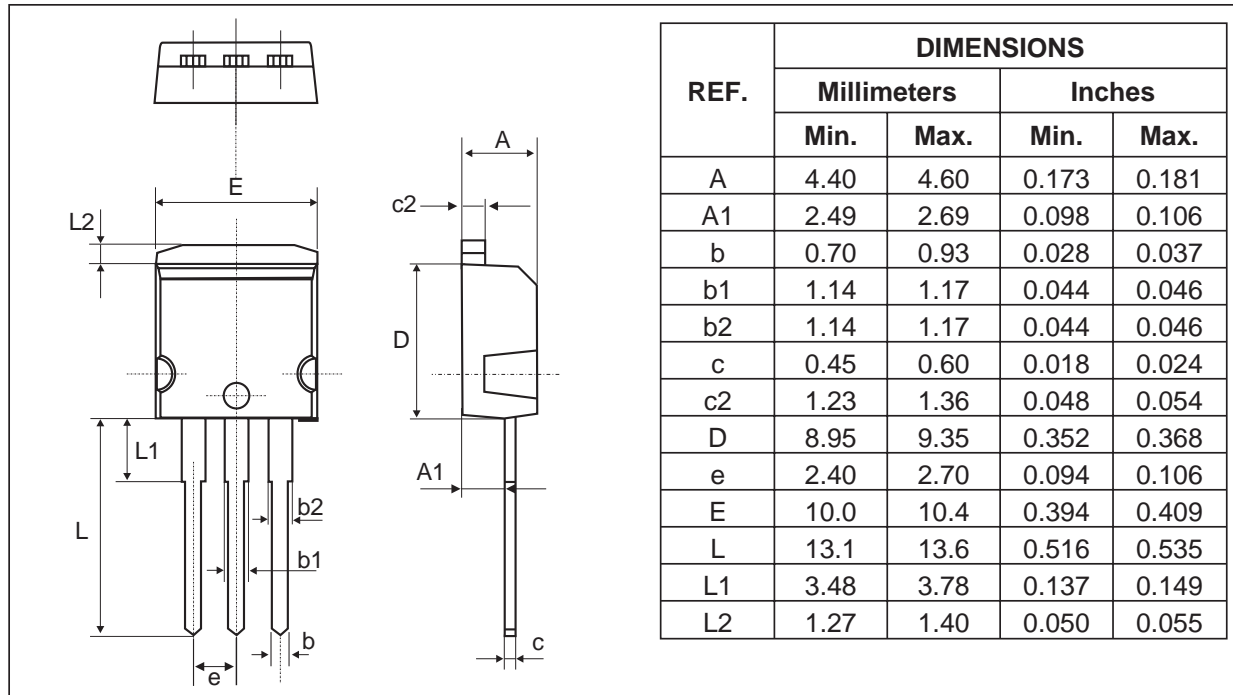

PACKAGE MECHANICAL DATA
TO-220FPAB

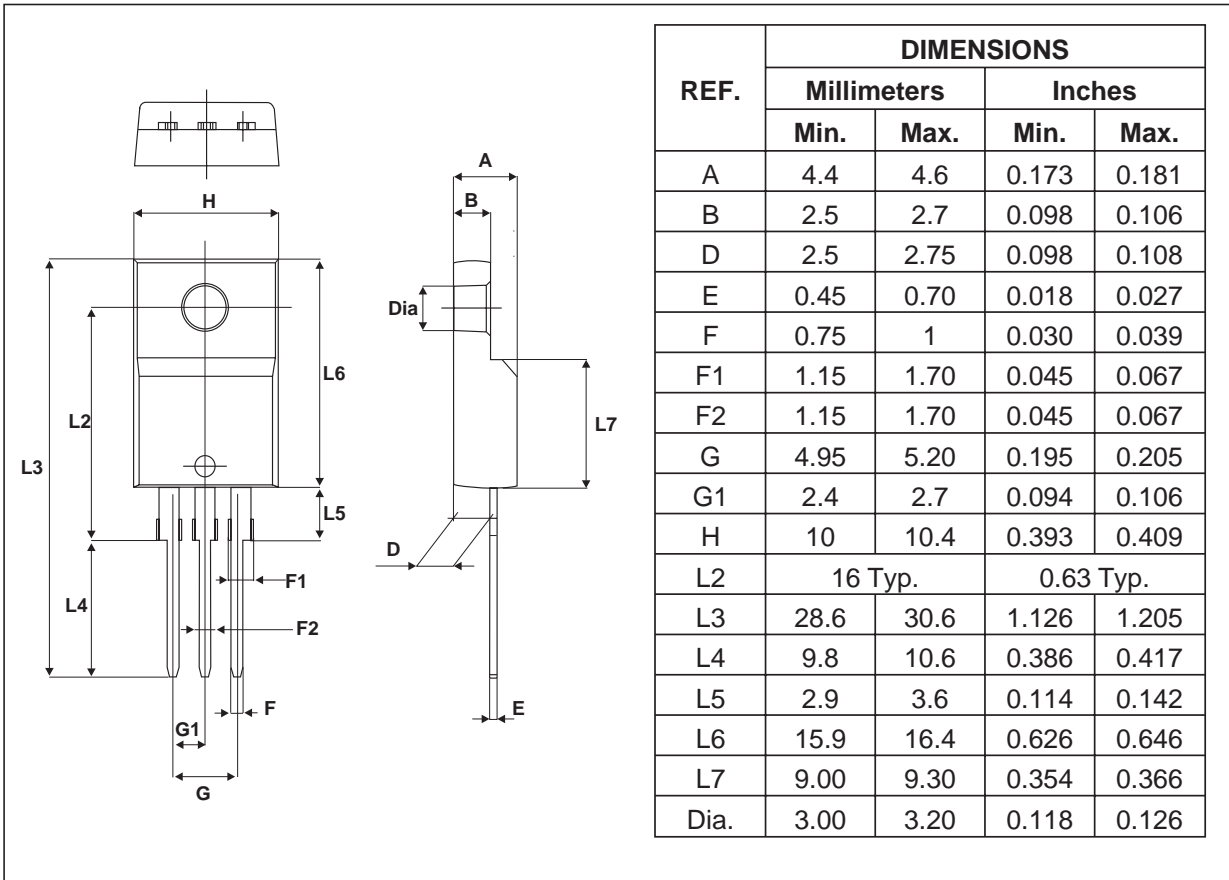

PACKAGE MECHANICAL DATA
D²PAK

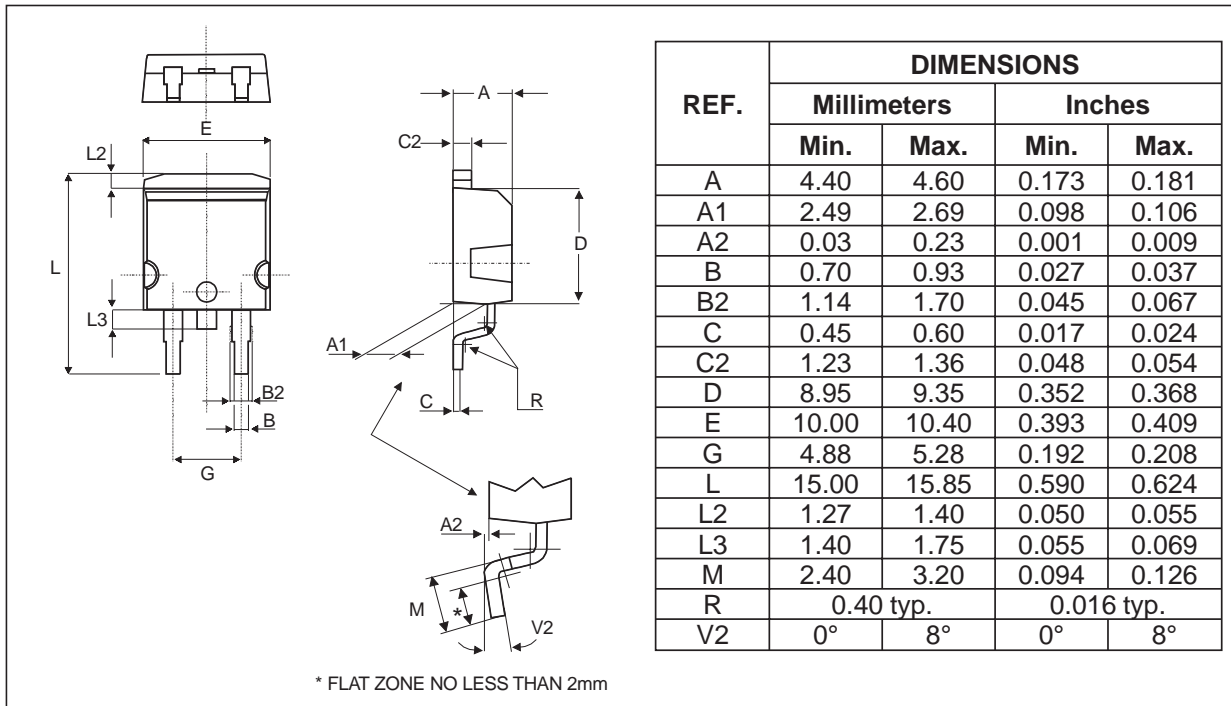

- Cooling method : by conduction (method C)

FOOT PRINT (in millimeters)
D²PAK

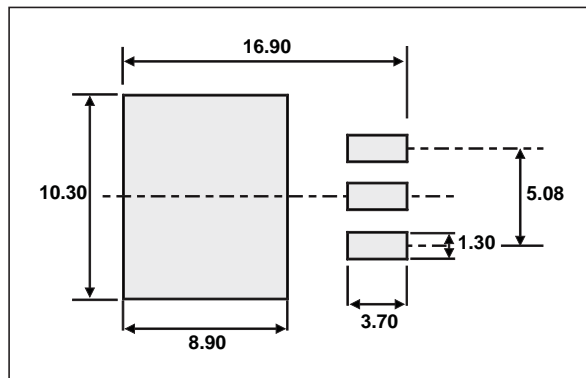

STPS30L45CG/CR/CT/CW/CFP

PACKAGE MECHANICAL DATA
TO-247

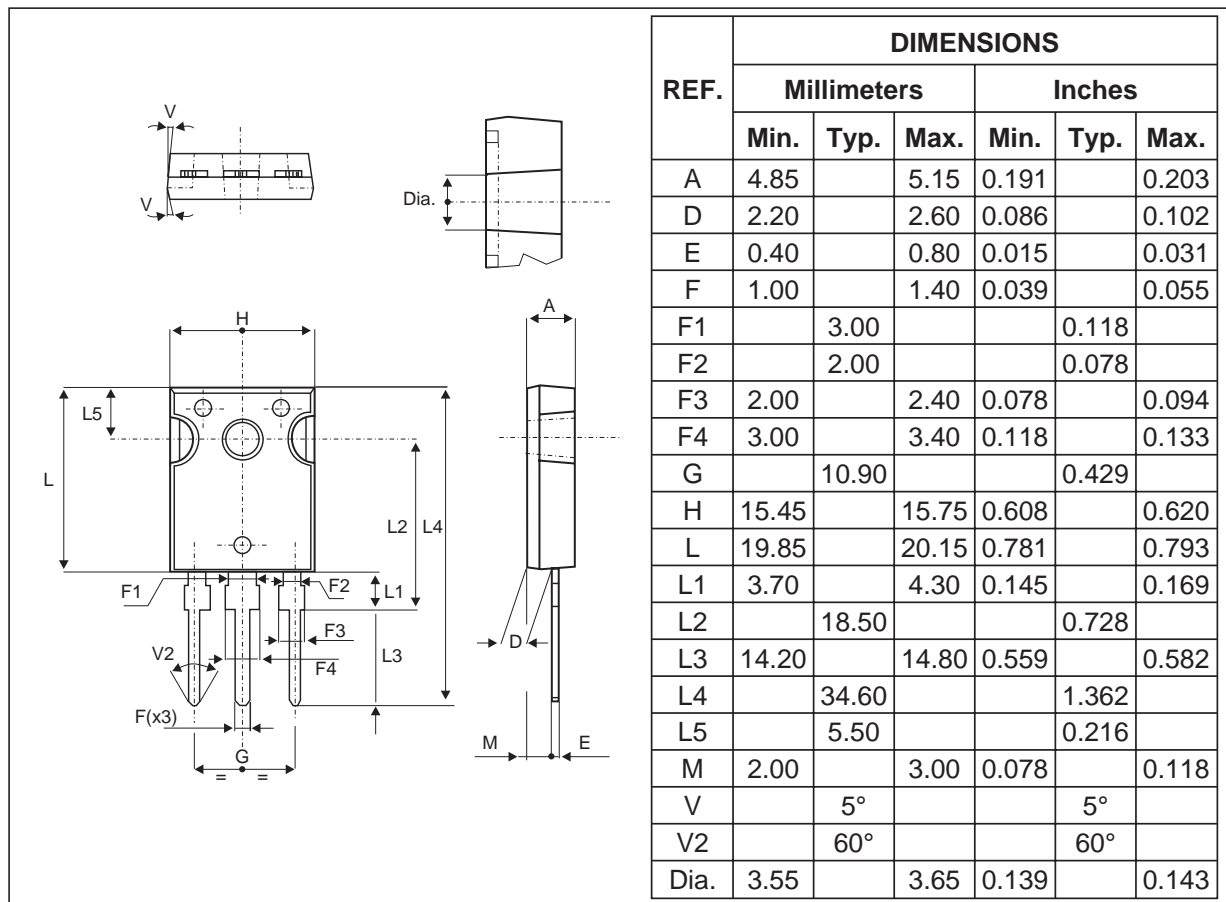

- Cooling method : C
- Recommended torque value : 0.8m.N
- Maximum torque value : 1.0m.N

Ordering type	Marking	Package	Weight	Base qty	Delivery mode
STPS30L45CT	STPS30L45CT	TO-220AB	2g	50	Tube
STPS30L45CG	STPS30L45CG	D ² PAK	1.8g	50	Tube
STPS30L45CG-TR	STPS30L45CG	D ² PAK	1.8g	500	Tape & reel
STPS30L45CW	STPS30L45CW	TO-247	4.4g	30	Tube
STPS30L45CR	STPS30L45CR	I ² PAK	1.4g	50	Tube
STPS30L45CFP	STPS30L45CFP	TO-220FPAB	1.9 g	50	Tube

- Epoxy meets UL94,V0

Information furnished is believed to be accurate and reliable. However, STMicroelectronics assumes no responsibility for the consequences of use of such information nor for any infringement of patents or other rights of third parties which may result from its use. No license is granted by implication or otherwise under any patent or patent rights of STMicroelectronics. Specifications mentioned in this publication are subject to change without notice. This publication supersedes and replaces all information previously supplied. STMicroelectronics products are not authorized for use as critical components in life support devices or systems without express written approval of STMicroelectronics.

The ST logo is a registered trademark of STMicroelectronics
 © 2002 STMicroelectronics - Printed in Italy - All rights reserved.
 STMicroelectronics GROUP OF COMPANIES
 Australia - Brazil - Canada - China - Finland - France - Germany
 Hong Kong - India - Israel - Italy - Japan - Malaysia - Malta - Morocco - Singapore
 Spain - Sweden - Switzerland - United Kingdom - United States.

<http://www.st.com>

