

3A Fixed Output Voltage LDO Regulator

General Description

The RT9172 series of low dropout linear regulators operate from a 2.25V to 6V input supply. A wide range of preset output voltage options is available. These low dropout linear regulators respond very fast to step changes in load, which are suitable for low voltage microprocessor applications. The RT9172 uses an internal P-MOSFET as the pass device, which does not cause extra GND current in heavy load and dropout condition. The shutdown mode of low operation current makes the IC suitable for power-saving systems. The other features include current limiting and over temperature protection.

Ordering Information

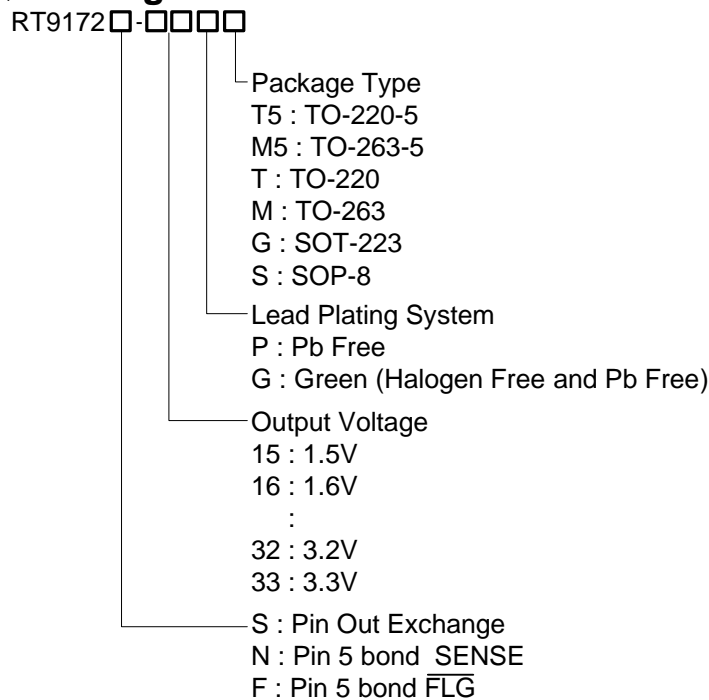

Note :

Richtek products are :

- ▶ RoHS compliant and compatible with the current requirements of IPC/JEDEC J-STD-020.
- ▶ Suitable for use in SnPb or Pb-free soldering processes.

Marking Information

For marking information, contact our sales representative directly or through a Richtek distributor located in your area.

Features

- Low Dropout Voltage
- Low Ground Pin Current
- Load Regulation of 0.4% at 3A
- 0.5mA Quiescent Current in Shutdown Mode
- Guaranteed Output Current of 3A DC
- Available in TO-263 and TO-220 Packages
- Output Voltage Accuracy $\pm 1.5\%$
- Error Flag Indicates Output Status
- Sense Option Improves Better Load Regulation
- Extremely Low Output Capacitor Requirements
- Over Temperature/Over- Current Protection
- RoHS Compliant and 100% Lead (Pb)-Free

Applications

- Microprocessor Power Supplies
- GTL, GTL+, BTL, and SSTL Bus Terminators
- Power Supplies for DSPs
- SCSI Terminator
- Post Regulators
- High Efficiency Linear Regulators
- Battery Chargers
- Other Battery Powered Applications

Pin Configurations

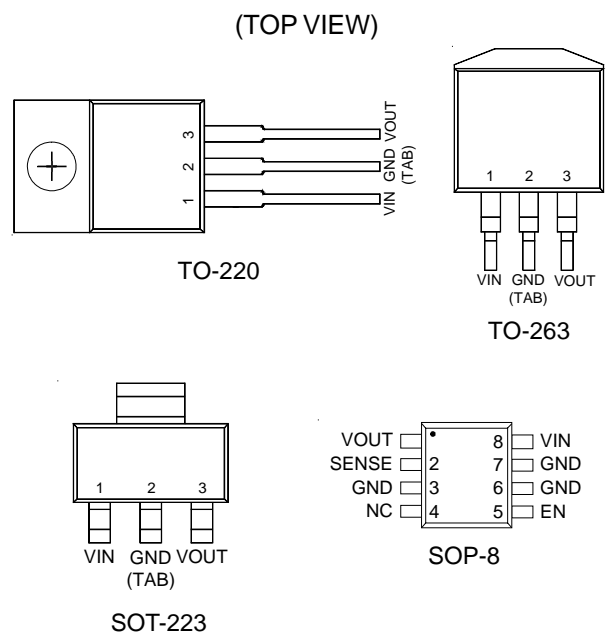

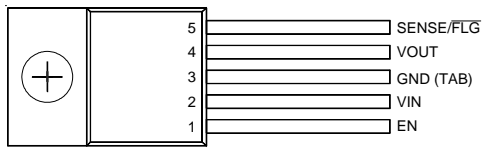

TO-220-5
RT9172N-□□xT5
RT9172F-□□xT5

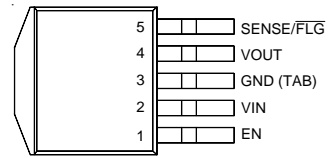

TO-263-5
RT9172N-□□xM5
RT9172F-□□xM5

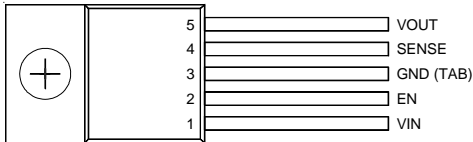

TO-220-5
RT9172S-□□xT5

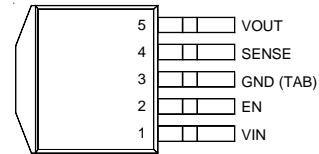

TO-263-5
RT9172S-□□xM5

Functional Pin Description

| Pin No. | | | | Pin Name | Pin Function |
|---------|---------|---------|--|----------|-----------------------------|
| RT9172F | RT9172N | RT9172S | RT9172- □□xT RT9172- □□xM RT9172- □□xG | | |
| 1 | 1 | 2 | -- | EN | Chip Enable. (Active Hight) |
| 2 | 2 | 1 | 1 | VIN | Power Input Voltage. |
| 3 | 3 | 3 | 2 | GND | Ground. |
| 4 | 4 | 5 | 3 | VOUT | Output Voltage. |
| 5 | -- | -- | -- | FLG | ERROR Flag. |
| -- | 5 | 4 | -- | SENSE | Remote Sense. |

Typical Application Circuit

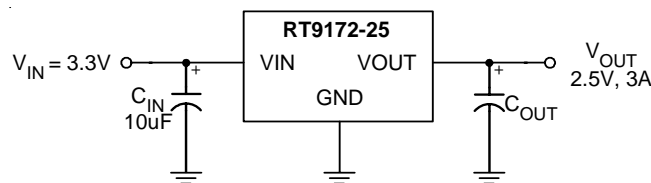

Figure 1

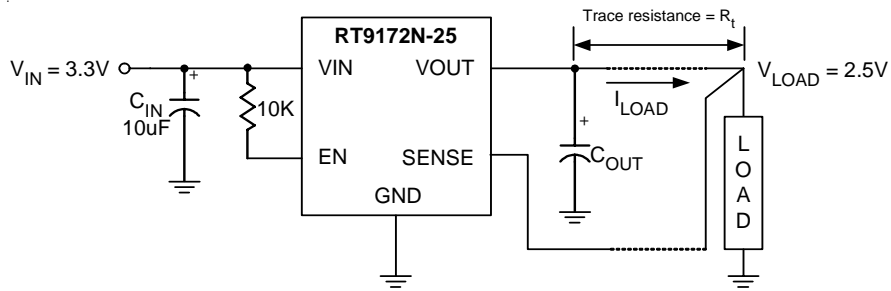

Figure 2

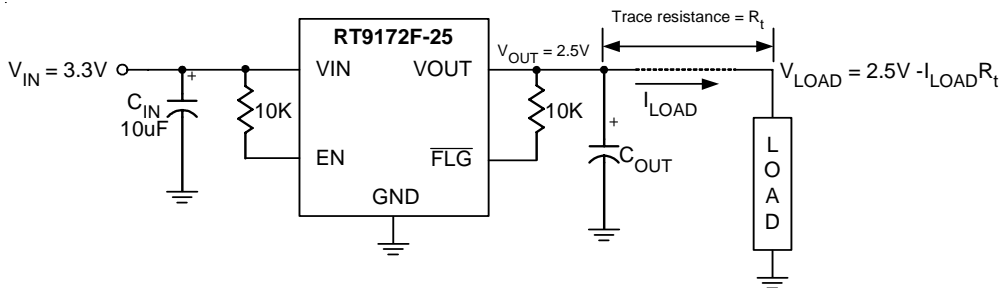
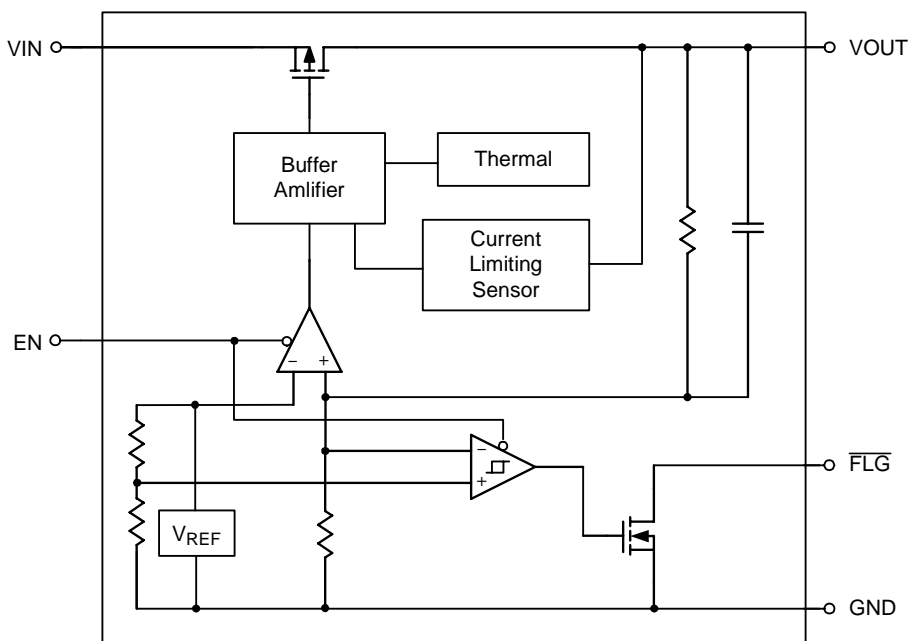

Figure 3

Recommend C_{OUT} : Please note that the part must be paralleled with the least a 100 μ F electrolytic capacitor when using a 10 μ F (or greater) ceramic type as the output capacitor to prevent the output oscillating.

Function Block Diagram

RT9172F



RT9172N/RT9172S

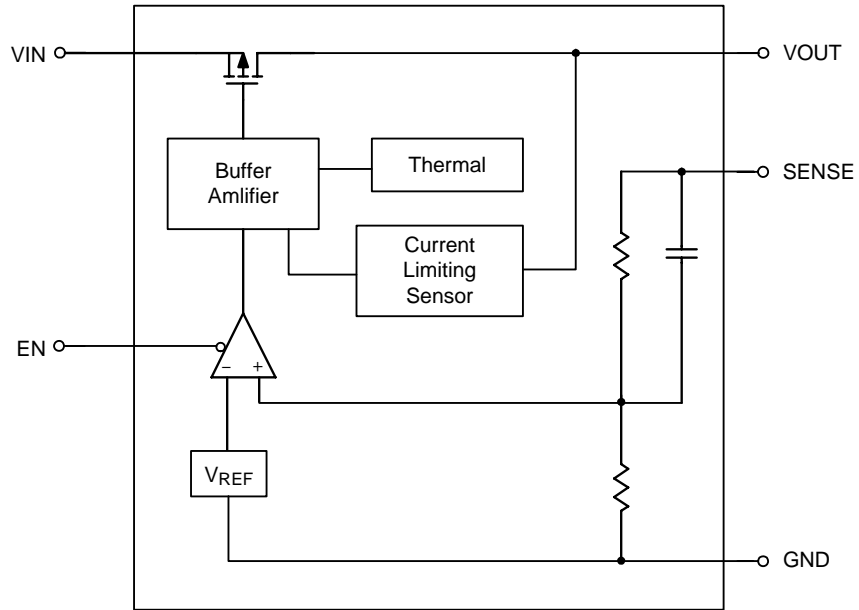

RT9172

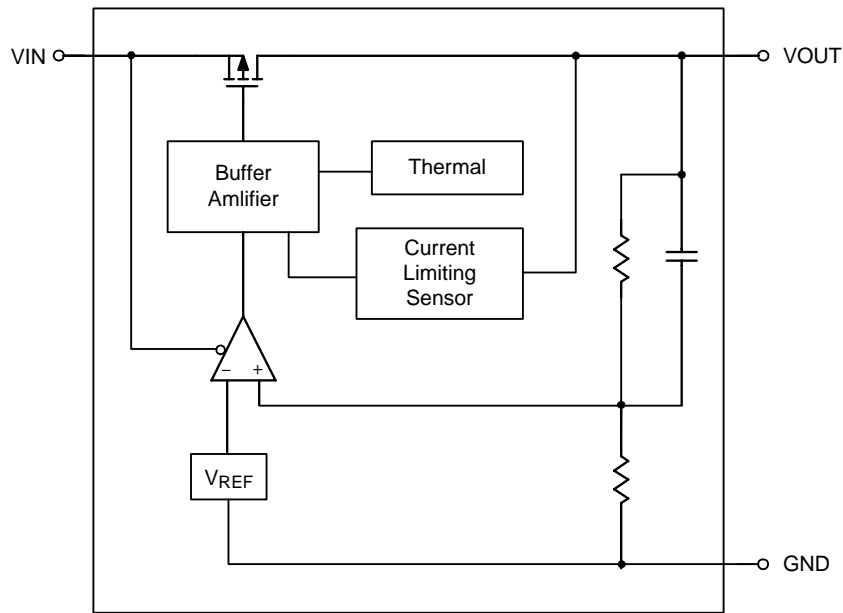

Absolute Maximum Ratings

- Input Voltage ----- 6V
- Power Dissipation, P_D @ $T_A = 25^\circ\text{C}$
 - SOT-223 ----- 0.741W
 - SOP-8 ----- 0.625W
 - TO-263 ----- 2.222W
 - TO-220 ----- 1.820W
- Package Thermal Resistance (Note 1)
 - SOT-223, θ_{JC} ----- 23°C/W
 - SOT-223, θ_{JA} ----- 135°C/W
 - SOP-8, θ_{JC} ----- 45°C/W
 - SOP-8, θ_{JA} ----- 160°C/W
 - TO-263, θ_{JC} ----- 7.8°C/W
 - TO-263, θ_{JA} ----- 45°C/W
 - TO-220, θ_{JC} ----- 15°C/W
 - TO-220, θ_{JA} ----- 55°C/W
- ESD Rating ----- 3 kV
- Storage Temperature Range ----- -65°C to 150°C
- Lead Temperature (Soldering, 10 sec.) ----- 260°C
- Junction Temperature Range ----- -40°C to 125°C

Electrical Characteristics

(Limits in standard typeface are for $T_A = 25^\circ\text{C}$, unless otherwise specified: $V_{IN} = V_{O(NOM)} + 1.0\text{V}$, $I_L = 10\text{mA}$,

$C_{OUT} = 10\mu\text{F}$ (Electrolytic), $V_{EN} = V_{IN}$)

| Parameter | Symbol | Test Conditions | Min | Typ | Max | Unit |
|------------------------------------|-------------------|--|------|------|-----|------------------|
| Output Voltage Tolerance | | | -1.5 | 0 | 1.5 | % |
| Input Voltage Range | V_{IN} | | 2.25 | -- | 5.5 | V |
| Line Regulation | ΔV_{LINE} | $V_{OUT} + 0.4\text{V} < V_{IN} < 5.5\text{V}$ | -- | 0.35 | 1 | % |
| Load Regulation | ΔV_{LOAD} | Note 2 | -- | 0.4 | 1 | % |
| | | Note 3 | -- | 0.1 | 0.4 | |
| | | Note 4 | -- | 0.1 | 0.4 | |
| Dropout Voltage | V_{DROP} | $I_L = 3\text{A}$ | -- | 400 | 700 | mV |
| Quiescent Current | I_Q | | -- | 1.2 | 3 | mA |
| Shutdown Supply Current | I_{GSD} | $V_{EN} = 0\text{V}$ | -- | 0.5 | 5 | μA |
| Peak Output Current | $I_{O(PEAK)}$ | | 3.5 | 5 | -- | A |
| Short Circuit Protection | | | | | | |
| Current Limit | I_{LIMIT} | | 3.5 | 5 | -- | A |
| Over Temperature Protection | | | | | | |
| Shutdown Threshold | T_{SD} | Guaranteed by design | -- | 170 | -- | $^\circ\text{C}$ |
| Thermal Shutdown Hysteresis | | Guaranteed by design | -- | 10 | -- | $^\circ\text{C}$ |

To be continued

| Parameter | Symbol | Test Conditions | Min | Typ | Max | Unit |
|--------------------------------------|---------------|-------------------|-----|----------|-----|------|
| Shutdown Function | | | | | | |
| EN Pin Shutdown Threshold | V_{EN} | Output = High | 1.2 | V_{IN} | -- | V |
| | | Output = Low | -- | 0 | 0.4 | |
| EN Input Current | | $V_{EN} = V_{IN}$ | -- | 0.1 | -- | nA |
| \overline{FLG} Pin Leakage Current | $I_{LEAKAGE}$ | | -- | 1 | -- | nA |
| \overline{FLG} Pin Sink Current | | $V_{FLG} = 0.5V$ | 2 | -- | -- | mA |

Note 1. θ_{JA} is measured in the natural convection at $T_A = 25^\circ C$ on a low effective thermal conductivity test board of JEDEC 51-3 thermal measurement standard. The case point of θ_{JC} is on the center of the exposed pad. The pad size is $125mm^2$ on TO-263 packages.

Note 2. RT9172-xX, RT9172F-XXxX5, $10mA < I_L < 3A$

Note 3. RT9172S-XXxX5, RT9172N-XXxX5, $10mA < I_L < 3A$

Note 4. RT9172xS, $10mA < I_L < 1.5A$

Typical Operating Characteristics

Temperature Stability

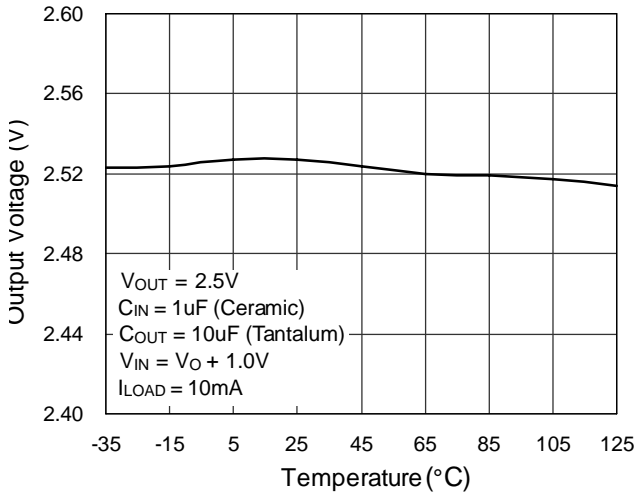

Quiescent Current vs. Load Current

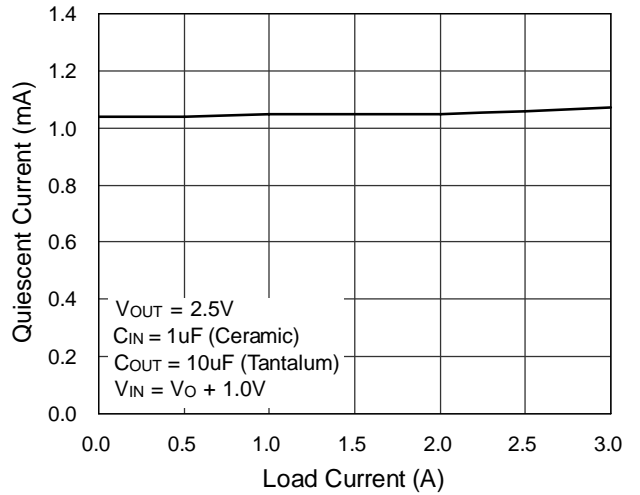

Quiescent Current vs. Temperature

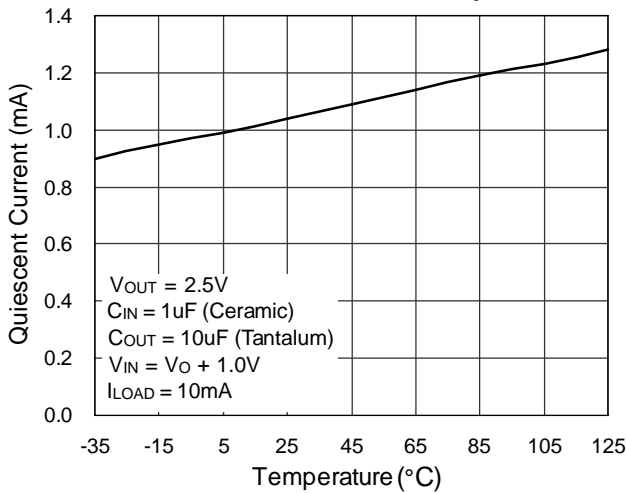

Quiescent Current vs. Supply Voltage

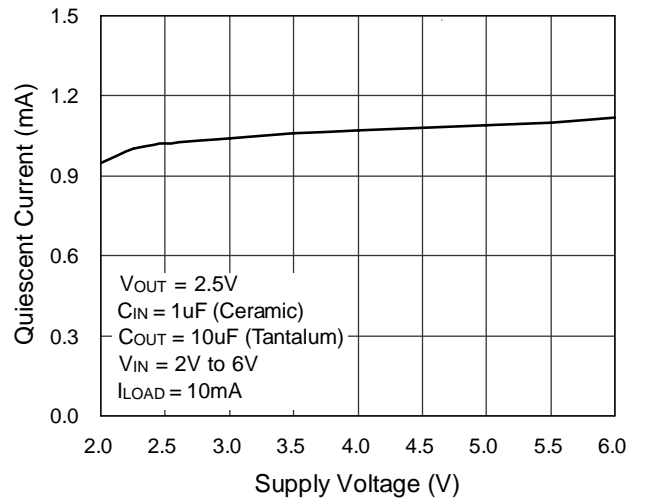

Dropout Voltage ($V_{IN} - V_{OUT}$)

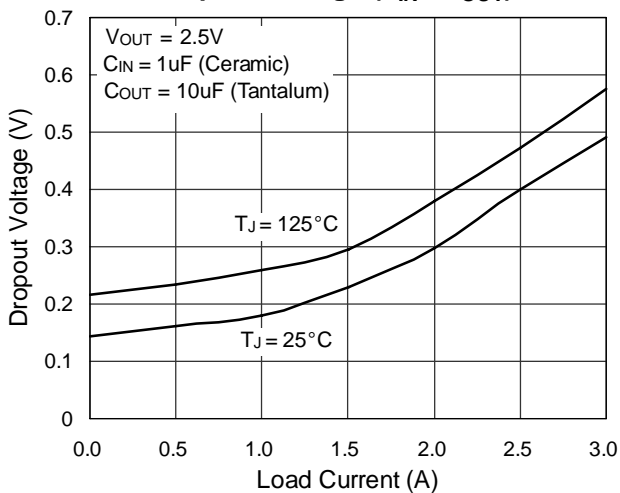

Current Limit vs. Temperature

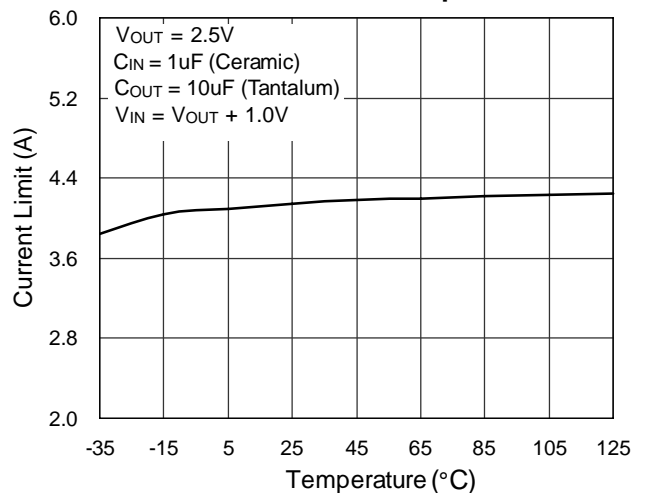

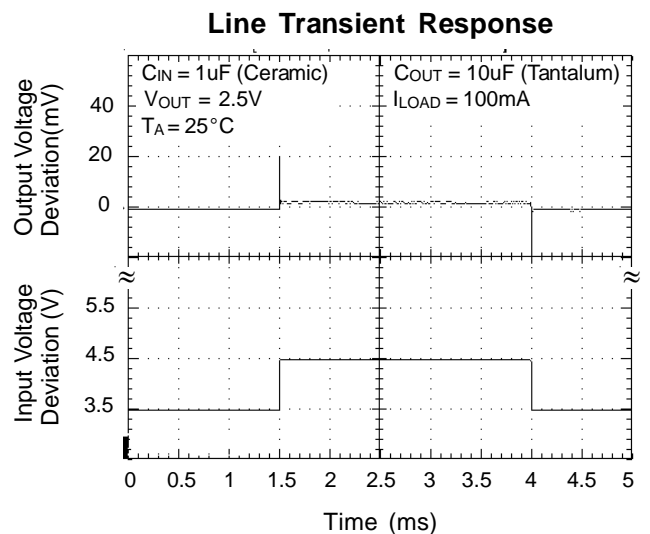
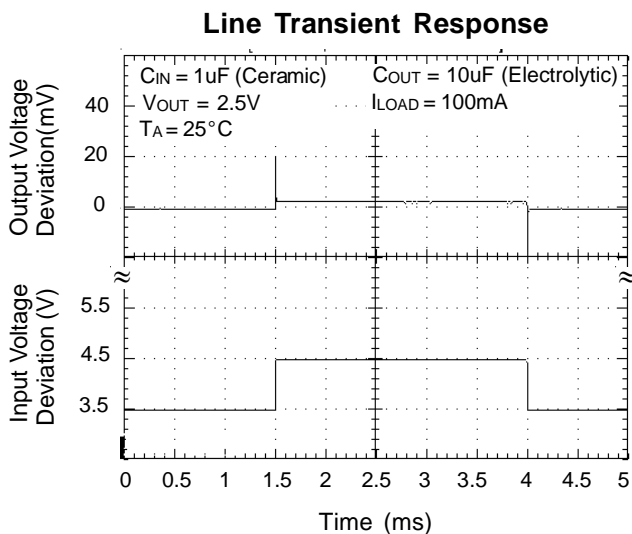
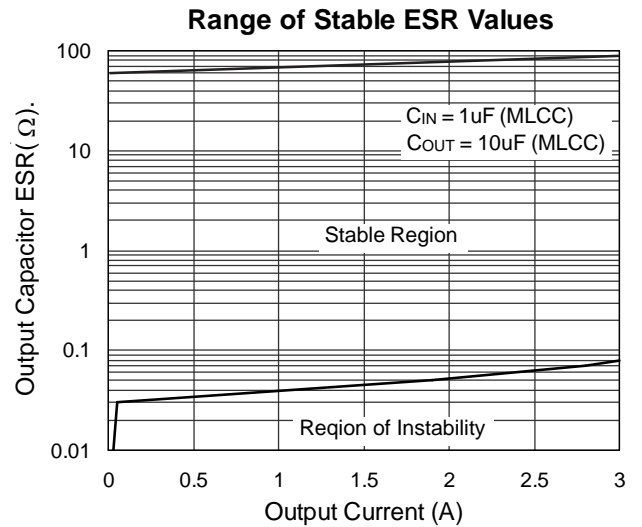
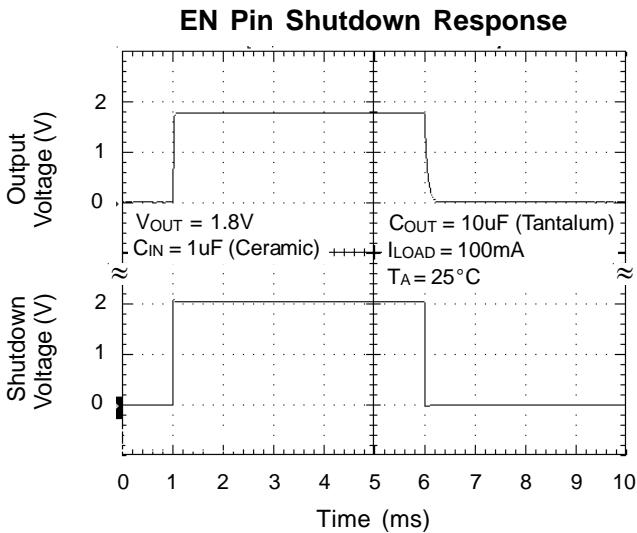
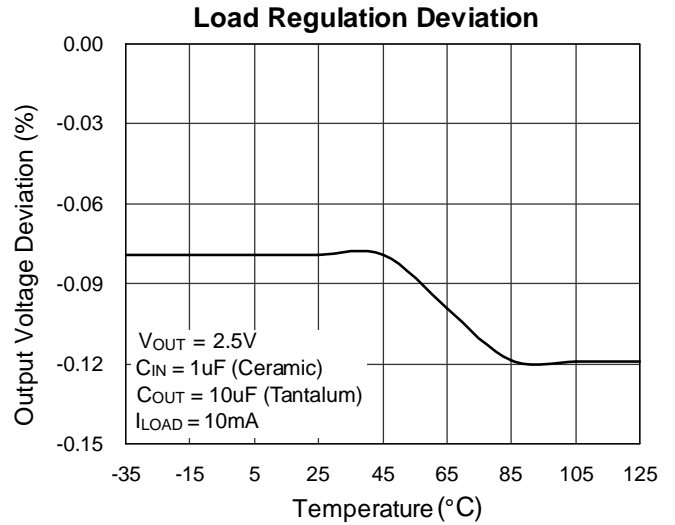
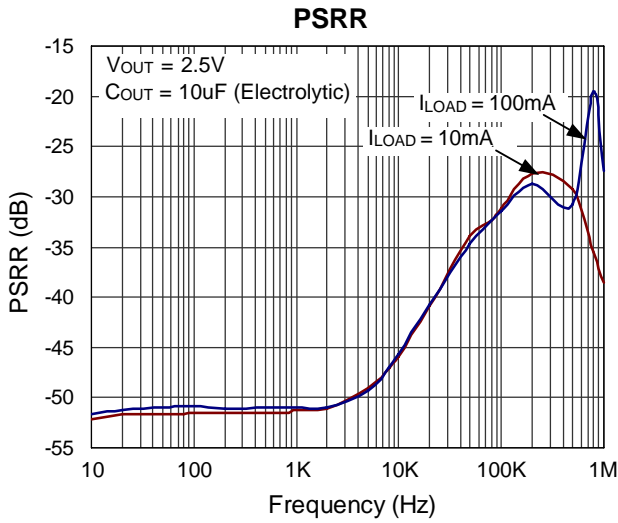

Load Transient Response

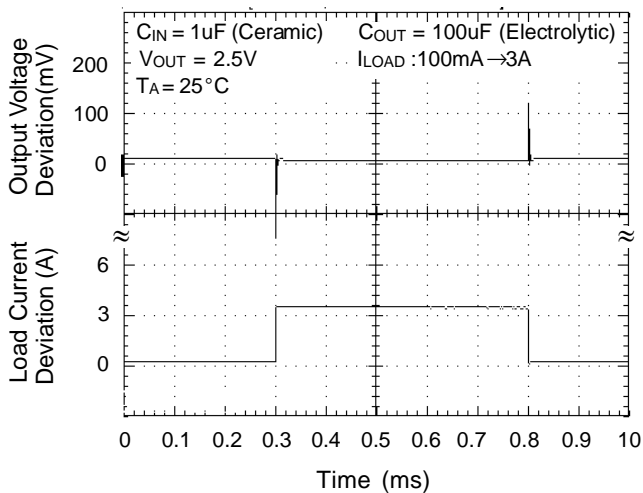

Load Transient Response

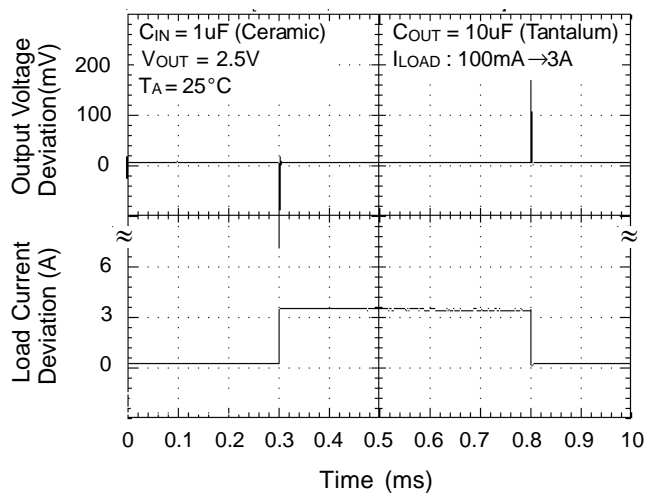

Noise Signal

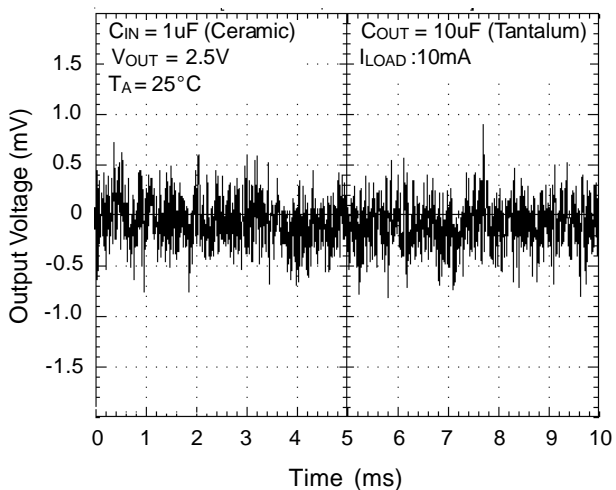

Noise Signal

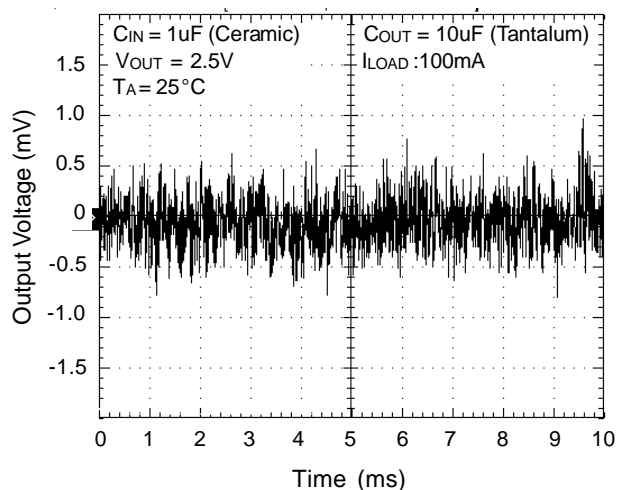

Application Information

Capacitor Selection

- An output capacitor as part of the device frequency compensation to maintain stability and improve transient response.
- Proper capacitor selection is important to ensure proper operation. When the output capacitor is 10 μ F or greater, the output capacitor should have an ESR less than 2 Ω . This will improve transient response as well as promote stability.
- Ultra-low-ESR capacitor (<100m Ω), such as ceramic chip capacitors, may promote instability. These very low ESR levels may cause an oscillation and/or underdamped transient response. A low-ESR solid tantalum capacitor works extremely well and provides good transient response and stability over temperature. Aluminum electrolytics can also be used, as long as the ESR of the capacitor is <2 Ω . The value of the output capacitor can be increased without limit. Higher capacitor values help to improve transient response and ripple rejection and reduce output noise.

The RT9172 requires a minimum input capacitance of 1 μ F between the input and ground pins to prevent any impedance interactions with the supply. The RT9172 requires a minimum of 10 μ F (tantalum, or electrolytic) capacitance between the output and ground pins for proper operation. Please note that the part must be paralleled with the least a 100 μ F electrolytic capacitor when using a 10 μ F (or greater) ceramic type as the output capacitor to prevent the output oscillating.

Error Operation ($\overline{\text{FLG}}$)

The RT9172 produces a logic low signal at the $\overline{\text{FLG}}$ pin when the output drops out of regulation due to low input voltage, current limiting, or thermal limiting.

The internal error $\overline{\text{FLG}}$ comparator has an open drain output stage. Hence, the $\overline{\text{FLG}}$ pin should be pulled high through a pull up resistor.

Sense Pin

In applications where the regulator output is not very close to the load, RT9172 can provide better remote load regulation using the SENSE pin. Figure 2. and Figure 3. depict the advantage of the SENSE option. RT9172 regulates the voltage at the output pin. Hence, the voltage at the remote load will be the regulator output voltage minus the drop across the trace resistance. For example, in the case of a 3.3V output, if the trace resistance is 100m Ω , the voltage at the remote load will be 3V with 3A of load current, I_{LOAD} . The RT9172 regulates the voltage at the sense pin. Connecting the sense pin to the remote load will provide regulation at the remote load, as shown in Figure 2. and Figure 3.

Chip Enable Operation

A CMOS logic level signal at the chip enable (EN) pin will turn-off the regulator. Pin EN must be actively terminated through a 10k Ω pull-up resistor for a proper operation. If this pin is driven from a source that actively pulls high and low (such as a CMOS rail to rail comparator), the pull-up resistor is not required. This pin must be tied to V_{IN} if not used.

Dropout Voltage

The dropout voltage of a regulator is defined as the minimum input-to-output differential required to stay within 2% of the output voltage. The RT9172 uses an internal MOSFET with an $R_{\text{DS(ON)}}$ 160m Ω . For CMOS LDOs, the dropout voltage is the product of the load current and the $R_{\text{DS(ON)}}$ of the internal MOSFET.

Maximum Output Current Capability

RT9172 can deliver a continuous current of 1.5 A over the full operating temperature range. A heatsink may be required depending on the maximum power dissipation and maximum ambient temperature of the application. Under all possible conditions, the junction temperature must be within the range specified under operating conditions. The total power dissipation of the device is given by : $PD = (V_{\text{IN}} - V_{\text{OUT}}) I_{\text{OUT}} + (V_{\text{IN}}) I_{\text{GND}}$

where I_{GND} is the operating ground current of the device (specified under Electrical Characteristics).

Outline Dimension

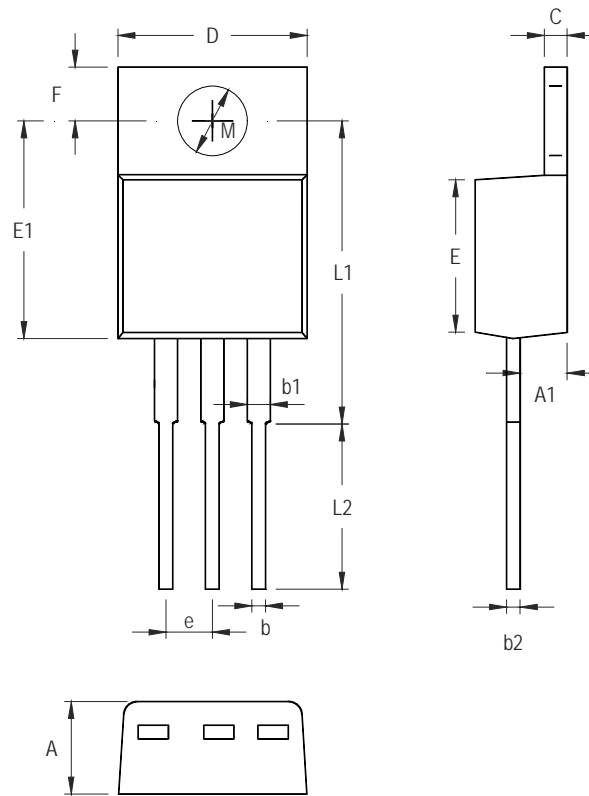

| Symbol | Dimensions In Millimeters | | Dimensions In Inches | |
|--------|---------------------------|--------|----------------------|-------|
| | Min | Max | Min | Max |
| A | 4.064 | 4.826 | 0.160 | 0.190 |
| A1 | 2.032 | 2.921 | 0.080 | 0.115 |
| b | 0.635 | 1.016 | 0.025 | 0.040 |
| b1 | 1.143 | 1.524 | 0.045 | 0.060 |
| b2 | 0.305 | 0.559 | 0.012 | 0.022 |
| C | 1.143 | 1.397 | 0.045 | 0.055 |
| D | 9.779 | 10.668 | 0.385 | 0.420 |
| E | 7.620 | 9.398 | 0.300 | 0.370 |
| e | 2.286 | 2.794 | 0.090 | 0.110 |
| E1 | 11.176 | 12.954 | 0.440 | 0.510 |
| F | 2.616 | 2.870 | 0.103 | 0.113 |
| L1 | 17.526 | 18.542 | 0.690 | 0.730 |
| L2 | 7.544 | 8.636 | 0.297 | 0.340 |
| M | 3.708 | 3.962 | 0.146 | 0.156 |

3-Lead TO- 220 Plastic Package

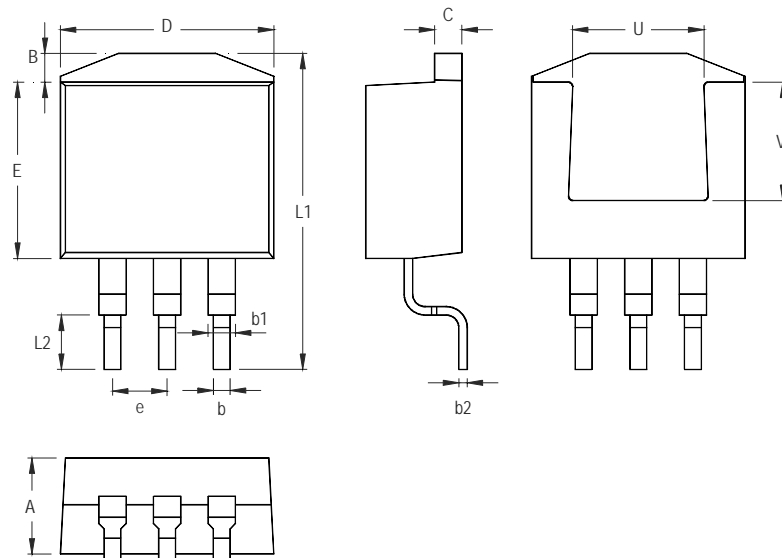

| Symbol | Dimensions In Millimeters | | Dimensions In Inches | |
|--------|---------------------------|--------|----------------------|-------|
| | Min | Max | Min | Max |
| A | 4.064 | 4.826 | 0.160 | 0.190 |
| B | 1.143 | 1.676 | 0.045 | 0.066 |
| b | 0.660 | 0.914 | 0.026 | 0.036 |
| b1 | 1.143 | 1.397 | 0.045 | 0.055 |
| b2 | 0.305 | 0.584 | 0.012 | 0.023 |
| C | 1.143 | 1.397 | 0.045 | 0.055 |
| D | 9.652 | 10.668 | 0.380 | 0.420 |
| E | 8.128 | 9.652 | 0.320 | 0.380 |
| e | 2.286 | 2.794 | 0.090 | 0.110 |
| L1 | 14.605 | 15.875 | 0.575 | 0.625 |
| L2 | 2.286 | 2.794 | 0.090 | 0.110 |
| U | 6.223 Ref. | | 0.245 Ref. | |
| V | 7.620 Ref. | | 0.300 Ref. | |

3-Lead TO- 263 Surface Mount

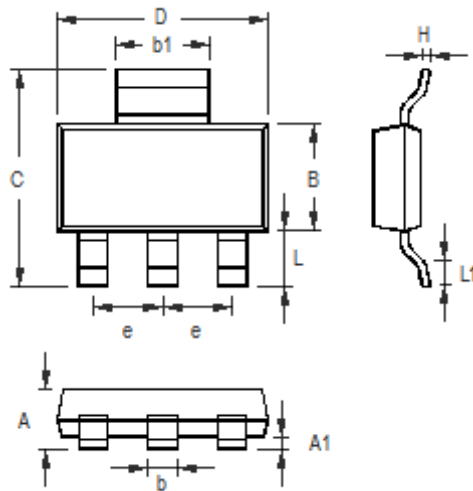

| Symbol | Dimensions In Millimeters | | Dimensions In Inches | |
|--------|---------------------------|-------|----------------------|-------|
| | Min | Max | Min | Max |
| A | 1.400 | 1.800 | 0.055 | 0.071 |
| A1 | 0.020 | 0.100 | 0.001 | 0.004 |
| b | 0.600 | 0.840 | 0.024 | 0.033 |
| B | 3.300 | 3.700 | 0.130 | 0.146 |
| C | 6.700 | 7.300 | 0.264 | 0.287 |
| D | 6.300 | 6.700 | 0.248 | 0.264 |
| b1 | 2.900 | 3.100 | 0.114 | 0.122 |
| e | 2.300 | | 0.091 | |
| H | 0.230 | 0.350 | 0.009 | 0.014 |
| L | 1.500 | 2.000 | 0.059 | 0.079 |
| L1 | 0.800 | 1.100 | 0.031 | 0.043 |

3-Lead SOT-223 Surface Mount Package

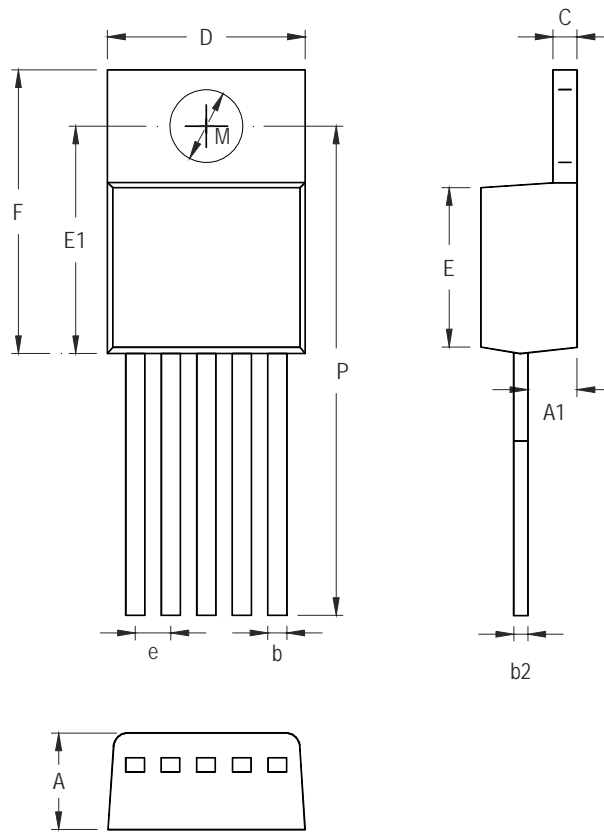

| Symbol | Dimensions In Millimeters | | Dimensions In Inches | |
|--------|---------------------------|--------|----------------------|-------|
| | Min | Max | Min | Max |
| A | 4.064 | 4.826 | 0.160 | 0.190 |
| A1 | 2.032 | 2.921 | 0.080 | 0.115 |
| b | 0.635 | 1.016 | 0.025 | 0.040 |
| b2 | 0.305 | 0.559 | 0.012 | 0.022 |
| C | 1.143 | 1.397 | 0.045 | 0.055 |
| e | 1.524 | 1.829 | 0.060 | 0.072 |
| D | 9.779 | 10.668 | 0.385 | 0.420 |
| E | 7.620 | 9.398 | 0.300 | 0.370 |
| E1 | 11.176 | 12.954 | 0.440 | 0.510 |
| F | 14.224 | 15.113 | 0.560 | 0.595 |
| M | 3.708 | 3.962 | 0.146 | 0.156 |
| P | 24.689 | 26.416 | 0.972 | 1.040 |

5-Lead TO-220 Plastic Package

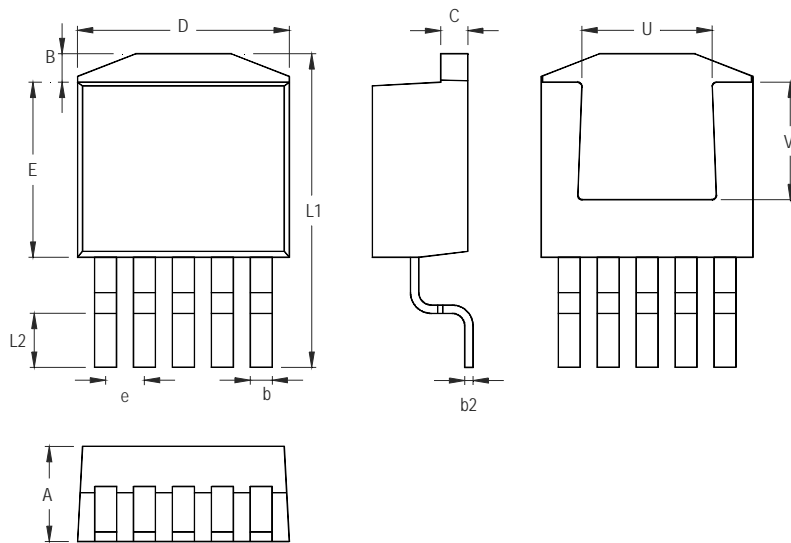

| Symbol | Dimensions In Millimeters | | Dimensions In Inches | |
|--------|---------------------------|--------|----------------------|-------|
| | Min | Max | Min | Max |
| A | 4.064 | 4.826 | 0.160 | 0.190 |
| B | 1.143 | 1.676 | 0.045 | 0.066 |
| b | 0.660 | 0.914 | 0.026 | 0.036 |
| b2 | 0.305 | 0.584 | 0.012 | 0.023 |
| C | 1.143 | 1.397 | 0.045 | 0.055 |
| D | 9.652 | 10.668 | 0.380 | 0.420 |
| E | 8.128 | 9.652 | 0.320 | 0.380 |
| e | 1.524 | 1.829 | 0.060 | 0.072 |
| L1 | 14.605 | 15.875 | 0.575 | 0.625 |
| L2 | 2.286 | 2.794 | 0.090 | 0.110 |
| U | 6.223 Ref. | | 0.245 Ref. | |
| V | 7.620 Ref. | | 0.300 Ref. | |

5-Lead TO-263 Plastic Surface Mount Package

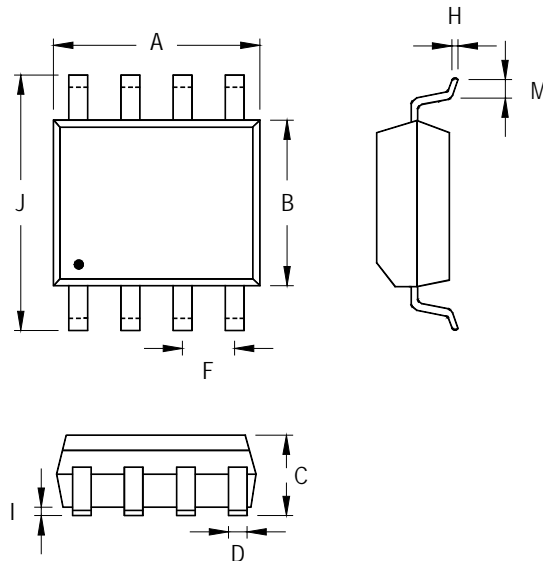

| Symbol | Dimensions In Millimeters | | Dimensions In Inches | |
|--------|---------------------------|-------|----------------------|-------|
| | Min | Max | Min | Max |
| A | 4.801 | 5.004 | 0.189 | 0.197 |
| B | 3.810 | 3.988 | 0.150 | 0.157 |
| C | 1.346 | 1.753 | 0.053 | 0.069 |
| D | 0.330 | 0.508 | 0.013 | 0.020 |
| F | 1.194 | 1.346 | 0.047 | 0.053 |
| H | 0.170 | 0.254 | 0.007 | 0.010 |
| I | 0.050 | 0.254 | 0.002 | 0.010 |
| J | 5.791 | 6.200 | 0.228 | 0.244 |
| M | 0.400 | 1.270 | 0.016 | 0.050 |

8-Lead SOP Plastic Package

Richtek Technology Corporation

Headquarter
 5F, No. 20, Taiyuen Street, Chupei City
 Hsinchu, Taiwan, R.O.C.
 Tel: (8863)5526789 Fax: (8863)5526611

Richtek Technology Corporation

Taipei Office (Marketing)
 5F, No. 95, Minchiuan Road, Hsintien City
 Taipei County, Taiwan, R.O.C.
 Tel: (8862)86672399 Fax: (8862)86672377
 Email: marketing@richtek.com

Information that is provided by Richtek Technology Corporation is believed to be accurate and reliable. Richtek reserves the right to make any change in circuit design, specification or other related things if necessary without notice at any time. No third party intellectual property infringement of the applications should be guaranteed by users when integrating Richtek products into any application. No legal responsibility for any said applications is assumed by Richtek.