

# DATA SHEET

## **74ALVC244**

### **Octal buffer/line driver; 3-state**

Product specification  
Supersedes data of 2003 Aug 11

2003 Sep 08

## Octal buffer/line driver; 3-state

## 74ALVC244

## FEATURES

- Wide supply voltage range from 1.65 to 3.6 V
- 3.6 V tolerant inputs/outputs
- CMOS low power consumption
- Direct interface with TTL levels (2.7 to 3.6 V)
- Power-down mode
- Latch-up performance exceeds 250 mA
- Complies with JEDEC standard:  
JESD8-7 (1.65 to 1.95 V)  
JESD8-5 (2.3 to 2.7 V)  
JESD8B/JESD36 (2.7 to 3.6 V)
- ESD protection:  
HBM EIA/JESD22-A114-A exceeds 2000 V  
MM EIA/JESD22-A115-A exceeds 200 V.

## DESCRIPTION

The 74ALVC244 is a high-performance, low-power, low-voltage, Si-gate CMOS device and superior to most advanced CMOS compatible TTL families.

The 74ALVC244 is an octal non-inverting buffer/line driver with 3-state outputs. The 3-state outputs are controlled by the output enable inputs  $1\overline{OE}$  and  $2\overline{OE}$ . A HIGH on  $n\overline{OE}$  causes the outputs to assume a high-impedance OFF-state. Schmitt-trigger action at all inputs makes the circuit highly tolerant for slower input rise and fall times.

## QUICK REFERENCE DATA

GND = 0 V;  $T_{amb} = 25\text{ }^{\circ}\text{C}$ .

SYMBOL	PARAMETER	CONDITIONS	TYPICAL	UNIT
$t_{PHL}/t_{PLH}$	propagation delay nAn to nYn	$V_{CC} = 1.8\text{ V}; C_L = 30\text{ pF}; R_L = 1\text{ k}\Omega$	2.7	ns
		$V_{CC} = 2.5\text{ V}; C_L = 30\text{ pF}; R_L = 500\text{ }\Omega$	2.0	ns
		$V_{CC} = 2.7\text{ V}; C_L = 50\text{ pF}; R_L = 500\text{ }\Omega$	2.3	ns
		$V_{CC} = 3.3\text{ V}; C_L = 50\text{ pF}; R_L = 500\text{ }\Omega$	2.2	ns
$C_I$	input capacitance		3.5	pF
$C_{PD}$	power dissipation capacitance per buffer	$V_{CC} = 3.3\text{ V}$ ; notes 1 and 2	20	pF

## Notes

1.  $C_{PD}$  is used to determine the dynamic power dissipation ( $P_D$  in  $\mu\text{W}$ ).

$$P_D = C_{PD} \times V_{CC}^2 \times f_i \times N + \Sigma(C_L \times V_{CC}^2 \times f_o) \text{ where:}$$

$f_i$  = input frequency in MHz;

$f_o$  = output frequency in MHz;

$C_L$  = output load capacitance in pF;

$V_{CC}$  = supply voltage in Volts;

$N$  = total load switching outputs;

$\Sigma(C_L \times V_{CC}^2 \times f_o)$  = sum of the outputs.

2. The condition is  $V_I = \text{GND to } V_{CC}$ .

## Octal buffer/line driver; 3-state

74ALVC244

## FUNCTION TABLE

See note 1.

INPUT		OUTPUT
$\overline{\text{nOE}}$	nAn	nYn
L	L	L
L	H	H
H	X	Z

## Note

1. H = HIGH voltage level;  
L = LOW voltage level;  
X = don't care;  
Z = high-impedance OFF-state.

## ORDERING INFORMATION

TYPE NUMBER	PACKAGE				
	TEMPERATURE RANGE	PINS	PACKAGE	MATERIAL	CODE
74ALVC244D	-40 to +85 °C	20	SO20	plastic	SOT163-1
74ALVC244PW	-40 to +85 °C	20	TSSOP20	plastic	SOT360-1
74ALVC244BQ	-40 to +85 °C	20	DHVQFN20	plastic	SOT764-1

## PINNING

PIN	SYMBOL	DESCRIPTION
1	$\overline{1OE}$	output enable input (active LOW)
2	1A0	data input
3	2Y0	bus output
4	1A1	data input
5	2Y1	bus output
6	1A2	data input
7	2Y2	bus output
8	1A3	data input
9	2Y3	bus output
10	GND	ground (0 V)

PIN	SYMBOL	DESCRIPTION
11	2A3	data input
12	1Y3	bus output
13	2A2	data input
14	1Y2	bus output
15	2A1	data input
16	1Y1	bus output
17	2A0	data input
18	1Y0	bus output
19	$\overline{2OE}$	output enable input (active LOW)
20	V <sub>CC</sub>	supply voltage

Octal buffer/line driver; 3-state

74ALVC244

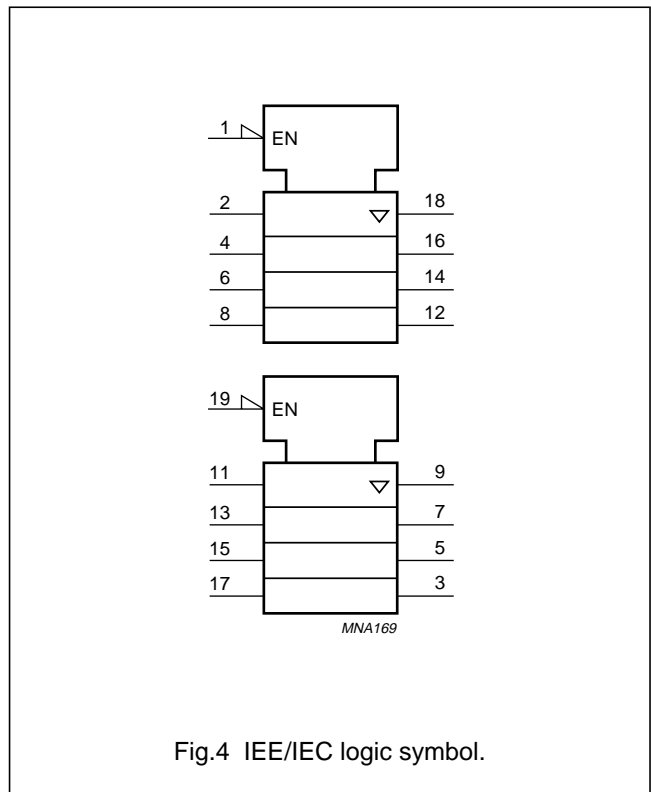
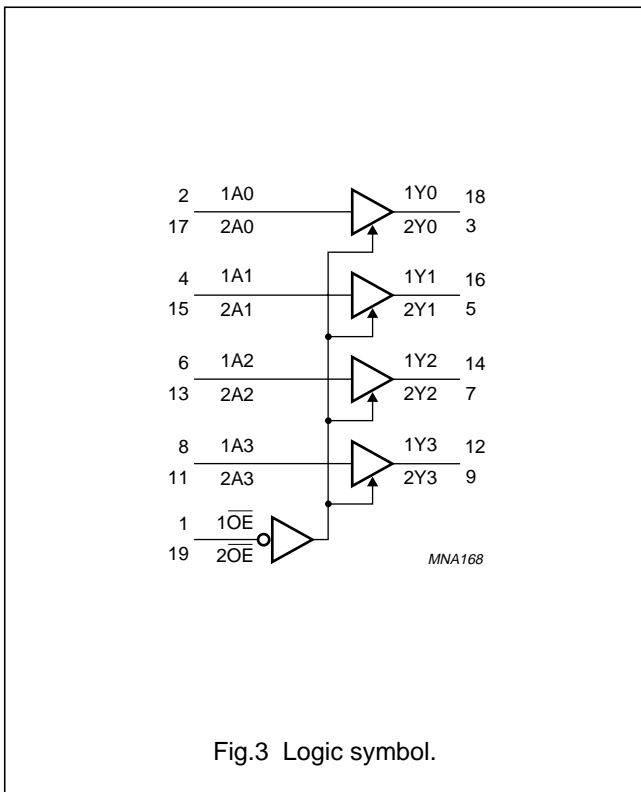
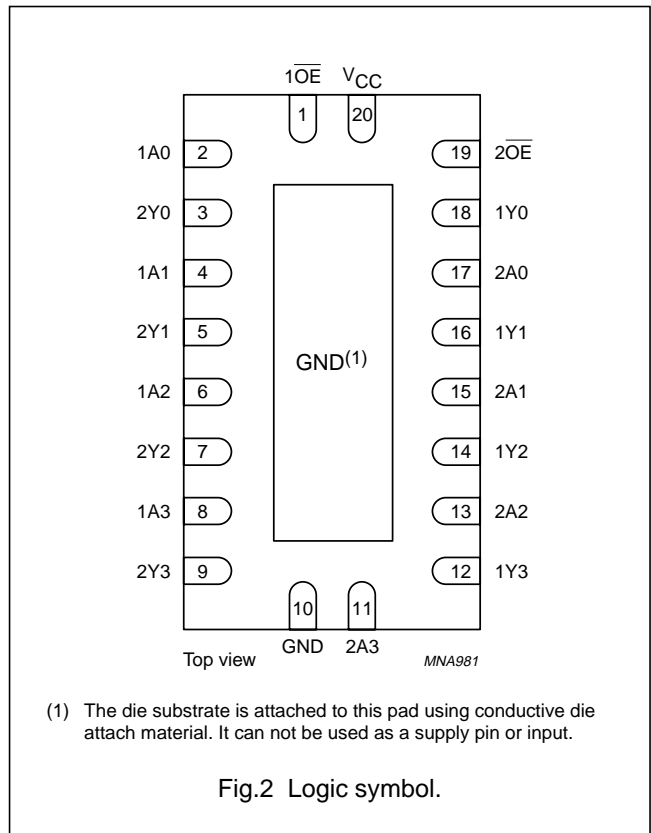
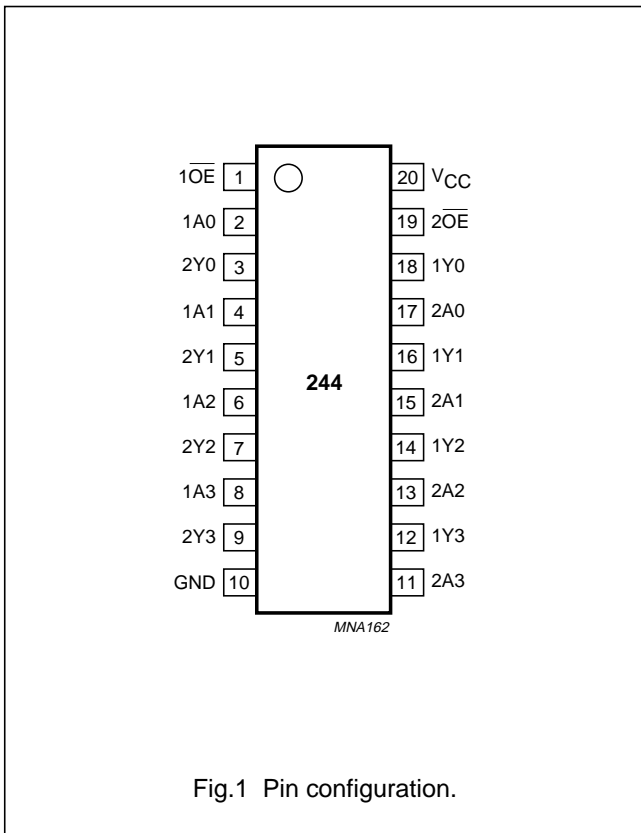

Octal buffer/line driver; 3-state

74ALVC244

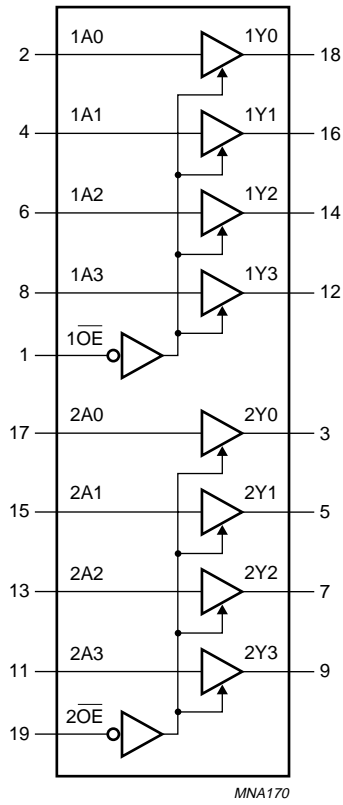

Fig.5 Logic diagram.

## Octal buffer/line driver; 3-state

74ALVC244

## RECOMMENDED OPERATING CONDITIONS

SYMBOL	PARAMETER	CONDITIONS	MIN.	MAX.	UNIT
$V_{CC}$	supply voltage		1.65	3.6	V
$V_I$	input voltage		0	3.6	V
$V_O$	output voltage	$V_{CC} = 1.65$ to $3.6$ V; enable mode	0	$V_{CC}$	V
		$V_{CC} = 1.65$ to $3.6$ V; disable mode	0	3.6	V
		$V_{CC} = 0$ V; Power-down mode	0	3.6	V
$T_{amb}$	operating ambient temperature		-40	+85	°C
$t_r, t_f$	input rise and fall times	$V_{CC} = 1.65$ to $2.7$ V	0	20	ns/V
		$V_{CC} = 2.7$ to $3.6$ V	0	10	ns/V

## LIMITING VALUES

In accordance with the Absolute Maximum Rating System (IEC 60134); voltages are referenced to GND (ground = 0 V).

SYMBOL	PARAMETER	CONDITIONS	MIN.	MAX.	UNIT
$V_{CC}$	supply voltage		-0.5	+4.6	V
$I_{IK}$	input diode current	$V_I < 0$	-	-50	mA
$V_I$	input voltage		-0.5	+4.6	V
$I_{OK}$	output diode current	$V_O > V_{CC}$ or $V_O < 0$	-	$\pm 50$	mA
$V_O$	output voltage	enable mode; notes 1 and 2	-0.5	$V_{CC} + 0.5$	V
		disable mode	-0.5	+4.6	V
		Power-down mode; note 2	-0.5	+4.6	V
$I_O$	output source or sink current	$V_O = 0$ to $V_{CC}$	-	$\pm 50$	mA
$I_{GND}, I_{CC}$	$V_{CC}$ or GND current		-	$\pm 100$	mA
$T_{stg}$	storage temperature		-65	+150	°C
$P_{tot}$	power dissipation	$T_{amb} = -40$ to $+85$ °C; note 3	-	500	mW

## Notes

- The input and output voltage ratings may be exceeded if the input and output current ratings are observed.
- When  $V_{CC} = 0$  V (Power-down mode), the output voltage can be 3.6 V in normal operation.
- For SO20 packages: above 70 °C derate linearly with 8 mW/K.  
For TSSOP20 packages: above 60 °C derate linearly with 5.5 mW/K.  
For DHVQFN20 packages: above 60 °C derate linearly with 4.5 mW/K.

## Octal buffer/line driver; 3-state

## 74ALVC244

## DC CHARACTERISTICS

At recommended operating conditions; voltages are referenced to GND (ground = 0 V).

SYMBOL	PARAMETER	TEST CONDITIONS		MIN.	TYP. <sup>(1)</sup>	MAX.	UNIT
		OTHER	V <sub>CC</sub> (V)				
<b>T<sub>amb</sub> = -40 to +85 °C</b>							
V <sub>IH</sub>	HIGH-level input voltage		1.65 to 1.95	0.65 × V <sub>CC</sub>	–	–	V
			2.3 to 2.7	1.7	–	–	V
			2.7 to 3.6	2	–	–	V
V <sub>IL</sub>	LOW-level input voltage		1.65 to 1.95	–	–	0.35 × V <sub>CC</sub>	V
			2.3 to 2.7	–	–	0.7	V
			2.7 to 3.6	–	–	0.8	V
V <sub>OL</sub>	LOW-level output voltage	V <sub>I</sub> = V <sub>IH</sub> or V <sub>IL</sub>	1.65 to 3.6	–	–	0.2	V
		I <sub>O</sub> = 100 μA	1.65	–	–	0.3	V
		I <sub>O</sub> = 6 mA	2.3	–	–	0.4	V
		I <sub>O</sub> = 12 mA	2.3	–	–	0.6	V
		I <sub>O</sub> = 18 mA	2.7	–	–	0.4	V
		I <sub>O</sub> = 18 mA	3.0	–	–	0.4	V
		I <sub>O</sub> = 24 mA	3.0	–	–	0.55	V
V <sub>OH</sub>	HIGH-level output voltage	V <sub>I</sub> = V <sub>IH</sub> or V <sub>IL</sub>	1.65 to 3.6	V <sub>CC</sub> – 0.2	–	–	V
		I <sub>O</sub> = –100 μA	1.65	1.25	–	–	V
		I <sub>O</sub> = –6 mA	2.3	1.8	–	–	V
		I <sub>O</sub> = –12 mA	2.3	1.7	–	–	V
		I <sub>O</sub> = –18 mA	2.7	2.2	–	–	V
		I <sub>O</sub> = –18 mA	3.0	2.4	–	–	V
		I <sub>O</sub> = –24 mA	3.0	2.2	–	–	V
I <sub>LI</sub>	input leakage current	V <sub>I</sub> = 3.6 V or GND	3.6	–	±0.1	±5	μA
I <sub>OZ</sub>	3-state output OFF-state current	V <sub>I</sub> = V <sub>IH</sub> or V <sub>IL</sub> ; V <sub>O</sub> = 3.6 V or GND; note 2	3.6	–	0.1	±10	μA
I <sub>off</sub>	power OFF leakage current	V <sub>I</sub> or V <sub>O</sub> = 3.6 V	0.0	–	±0.1	±10	μA
I <sub>CC</sub>	quiescent supply current	V <sub>I</sub> = V <sub>CC</sub> or GND; I <sub>O</sub> = 0	3.6	–	0.2	20	μA
ΔI <sub>CC</sub>	additional quiescent supply current per input pin	V <sub>I</sub> = V <sub>CC</sub> – 0.6 V; I <sub>O</sub> = 0	3.0 to 3.6	–	5	750	μA

## Notes

1. All typical values are measured at T<sub>amb</sub> = 25 °C.
2. For transceivers, the parameters I<sub>OZ</sub> includes the input leakage current.

Octal buffer/line driver; 3-state

74ALVC244

AC CHARACTERISTICS

SYMBOL	PARAMETER	TEST CONDITIONS		MIN.	TYP. <sup>(1)</sup>	MAX.	UNIT
		WAVEFORMS	V <sub>CC</sub> (V)				
<b>T<sub>amb</sub> = -40 to +85 °C</b>							
t <sub>PHL</sub> /t <sub>PLH</sub>	propagation delay nAn to nYn	see Figs 6 and 8	1.65 to 1.95	1.0	2.7	4.4	ns
			2.3 to 2.7	1.0	2.0	3.1	ns
			2.7	1.0	2.3	3.1	ns
			3.0 to 3.6	1.0	2.2	2.8	ns
t <sub>PZH</sub> /t <sub>PZL</sub>	3-state output enable time n $\overline{OE}$ to nYn	see Figs 7 and 8	1.65 to 1.95	1.0	3.4	6.9	ns
			2.3 to 2.7	1.0	2.6	5.4	ns
			2.7	1.0	3.2	5.3	ns
			3.0 to 3.6	1.0	2.5	4.5	ns
t <sub>PHZ</sub> /t <sub>PLZ</sub>	3-state output disable time n $\overline{OE}$ to nYn	see Figs 7 and 8	1.65 to 1.95	1.0	3.8	5.9	ns
			2.3 to 2.7	1.0	2.2	4.1	ns
			2.7	1.0	3.0	4.4	ns
			3.0 to 3.6	1.0	2.9	4.2	ns

Note

1. All typical values are measured at T<sub>amb</sub> = 25 °C.

AC WAVEFORMS

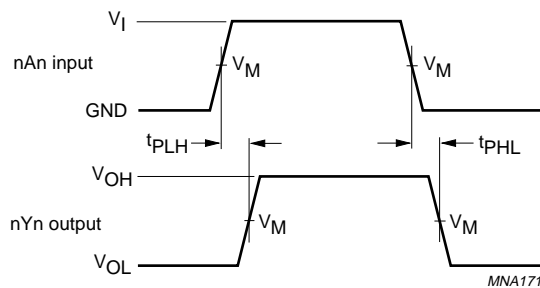

V <sub>CC</sub>	V <sub>M</sub>	INPUT	
		V <sub>I</sub>	t <sub>r</sub> = t <sub>f</sub>
1.65 to 1.95 V	0.5 × V <sub>CC</sub>	V <sub>CC</sub>	≤ 2.0 ns
2.3 to 2.7 V	0.5 × V <sub>CC</sub>	V <sub>CC</sub>	≤ 2.0 ns
2.7 V	1.5 V	2.7 V	≤ 2.5 ns
3.0 to 3.6 V	1.5 V	2.7 V	≤ 2.5 ns

Fig.6 Input nAn to output nYn propagation delay times.



Octal buffer/line driver; 3-state

74ALVC244

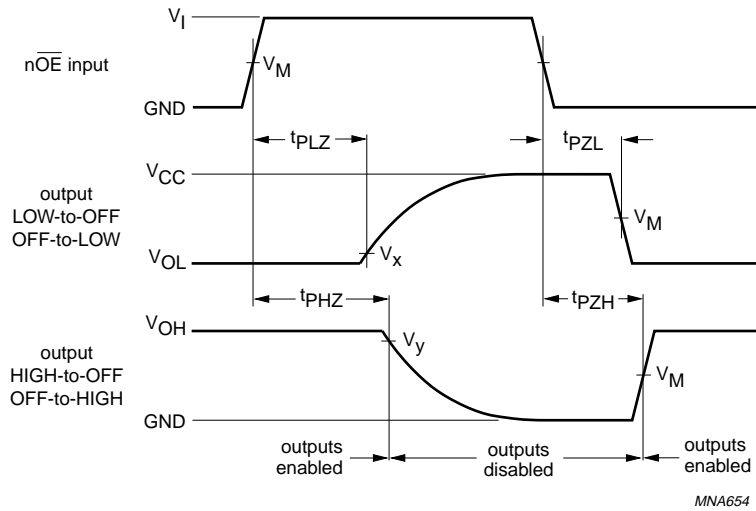

MNA654

V <sub>CC</sub>	V <sub>M</sub>	INPUT	
		V <sub>I</sub>	t <sub>r</sub> = t <sub>f</sub>
1.65 to 1.95 V	0.5 × V <sub>CC</sub>	V <sub>CC</sub>	≤ 2.0 ns
2.3 to 2.7 V	0.5 × V <sub>CC</sub>	V <sub>CC</sub>	≤ 2.0 ns
2.7 V	1.5 V	2.7 V	≤ 2.5 ns
3.0 to 3.6 V	1.5 V	2.7 V	≤ 2.5 ns

V<sub>x</sub> = V<sub>OL</sub> + 0.3 V at V<sub>CC</sub> ≥ 2.7 V;  
 V<sub>x</sub> = V<sub>OL</sub> + 0.15 V at V<sub>CC</sub> < 2.7 V;  
 V<sub>y</sub> = V<sub>OH</sub> - 0.3 V at V<sub>CC</sub> ≥ 2.7 V;  
 V<sub>y</sub> = V<sub>OH</sub> - 0.15 V at V<sub>CC</sub> < 2.7 V.

V<sub>OL</sub> and V<sub>OH</sub> are typical output voltage drop that occur with the output load.

Fig.7 3-state enable and disable times.

Octal buffer/line driver; 3-state

74ALVC244

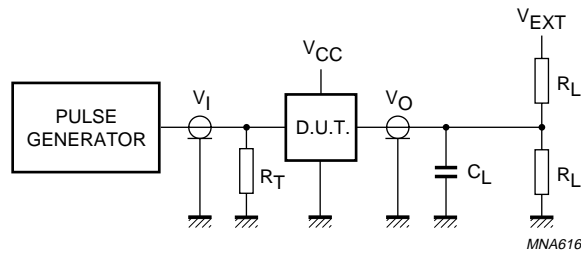

V <sub>CC</sub>	V <sub>I</sub>	C <sub>L</sub>	R <sub>L</sub>	V <sub>EXT</sub>		
				t <sub>PLH</sub> /t <sub>PHL</sub>	t <sub>PZH</sub> /t <sub>PHZ</sub>	t <sub>PZL</sub> /t <sub>PLZ</sub>
1.65 to 1.95 V	V <sub>CC</sub>	30 pF	1 kΩ	open	GND	2 × V <sub>CC</sub>
2.3 to 2.7 V	V <sub>CC</sub>	30 pF	500 Ω	open	GND	2 × V <sub>CC</sub>
2.7 V	2.7 V	50 pF	500 Ω	open	GND	6 V
3.0 to 3.6 V	2.7 V	50 pF	500 Ω	open	GND	6 V

Definitions for test circuit:

R<sub>L</sub> = Load resistor.

C<sub>L</sub> = Load capacitance including jig and probe capacitance.

R<sub>T</sub> = Termination resistance should be equal to the output impedance Z<sub>o</sub> of the pulse generator.

Fig.8 Load circuitry for switching times.

Octal buffer/line driver; 3-state

74ALVC244

PACKAGE OUTLINES

SO20: plastic small outline package; 20 leads; body width 7.5 mm

SOT163-1

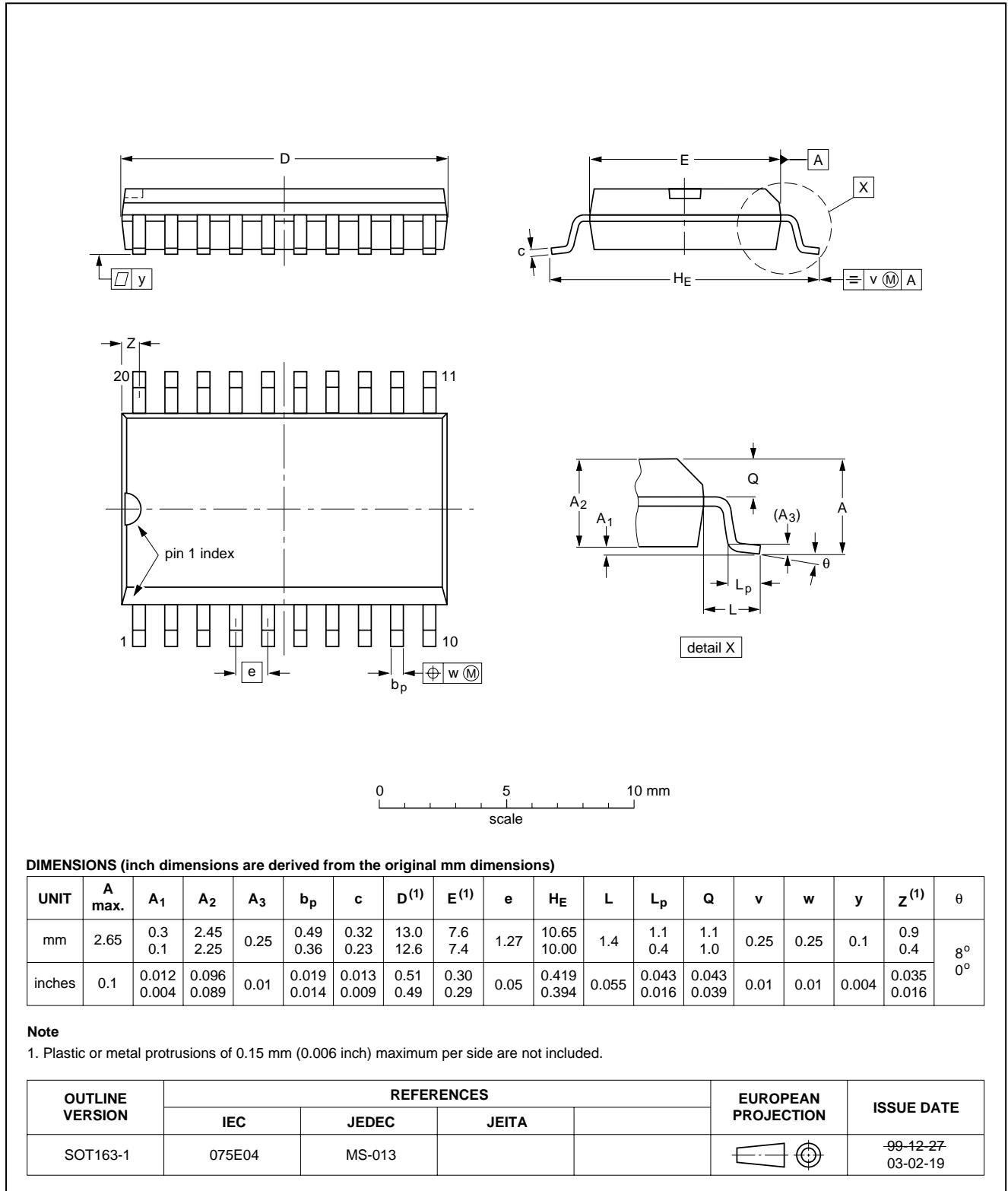

Octal buffer/line driver; 3-state

74ALVC244

TSSOP20: plastic thin shrink small outline package; 20 leads; body width 4.4 mm

SOT360-1

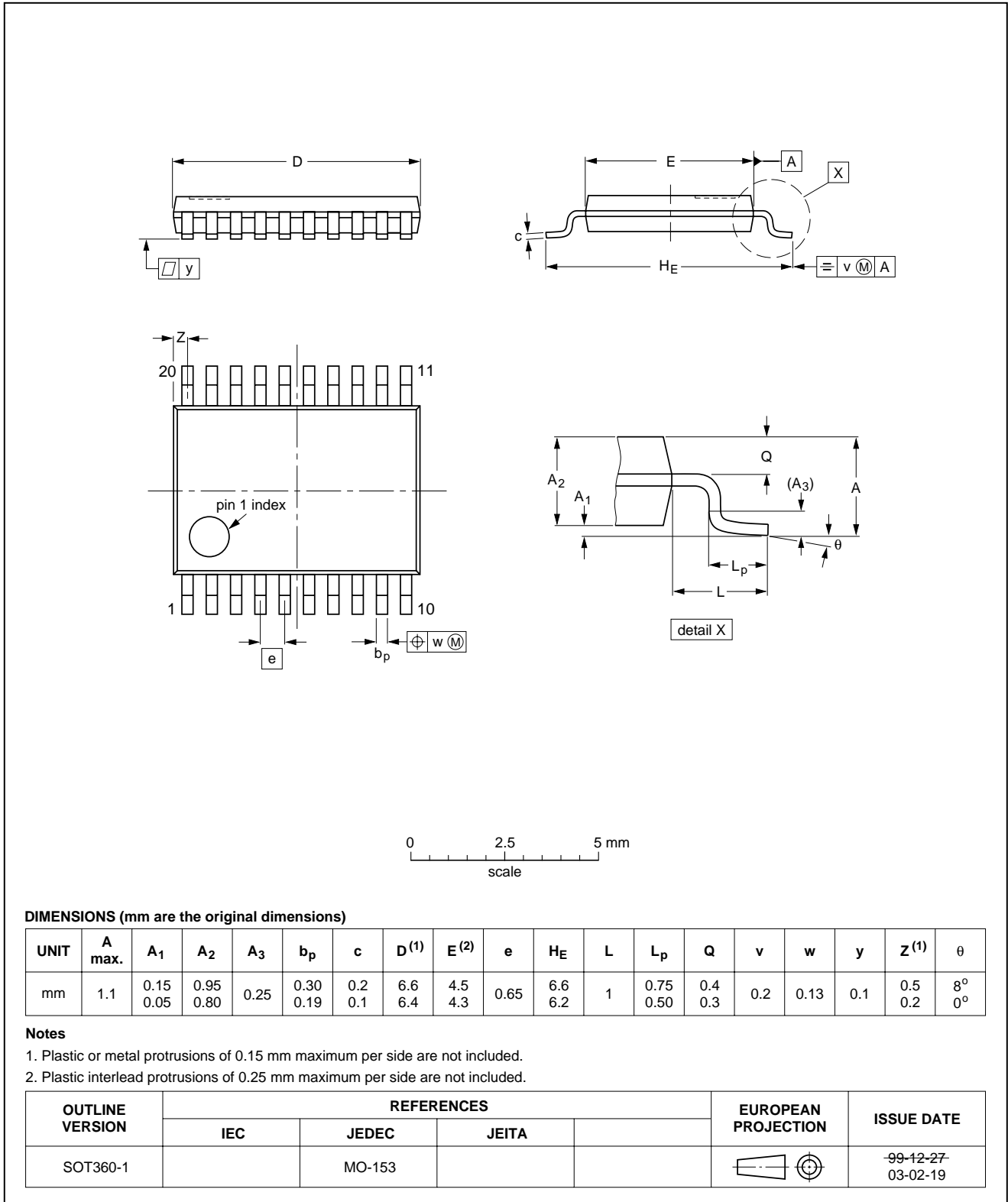

Octal buffer/line driver; 3-state

74ALVC244

DHVQFN20: plastic dual in-line compatible thermal enhanced very thin quad flat package; no leads; 20 terminals; body 2.5 x 4.5 x 0.85 mm

SOT764-1

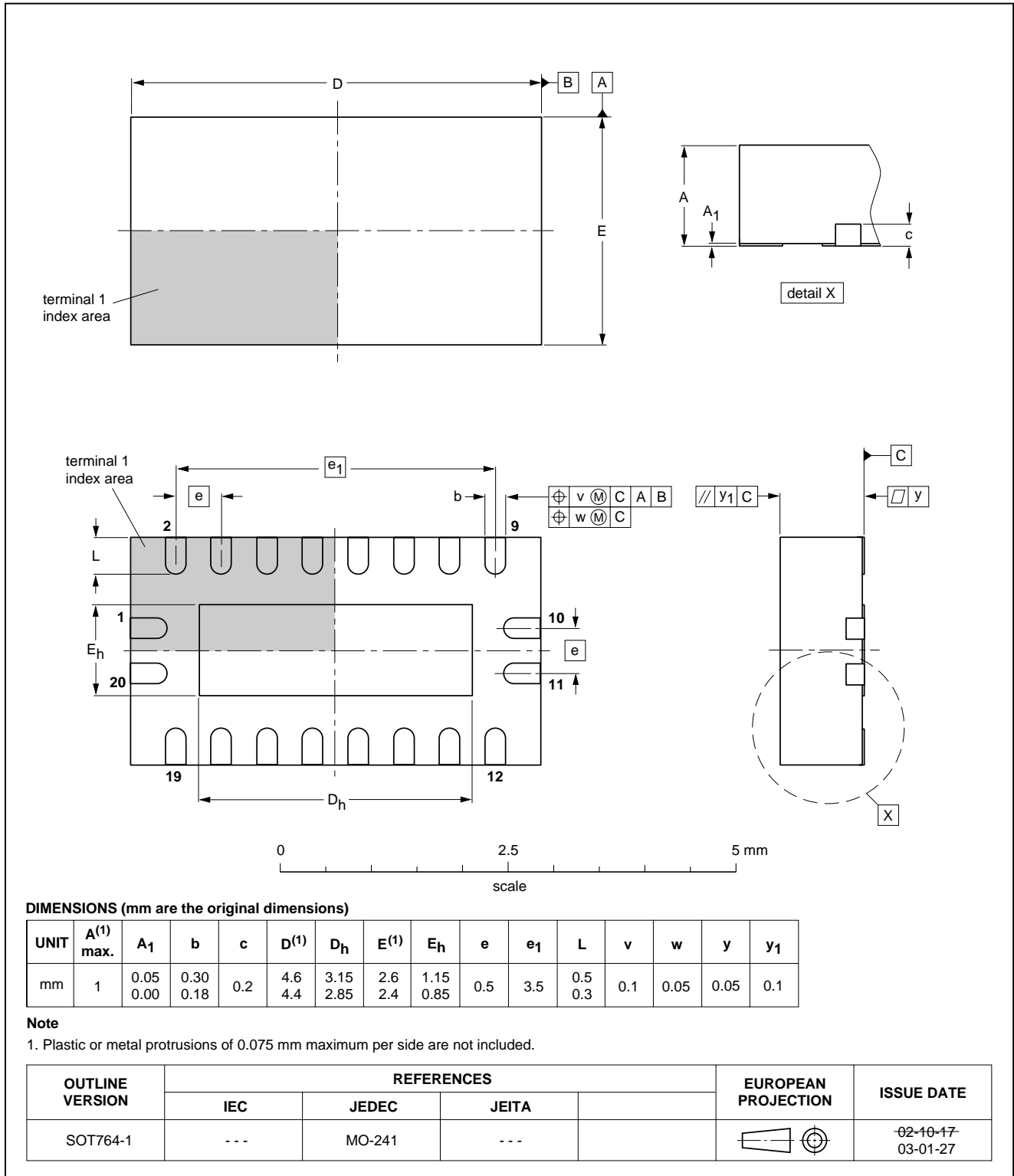

## Octal buffer/line driver; 3-state

74ALVC244

## DATA SHEET STATUS

LEVEL	DATA SHEET STATUS <sup>(1)</sup>	PRODUCT STATUS <sup>(2)(3)</sup>	DEFINITION
I	Objective data	Development	This data sheet contains data from the objective specification for product development. Philips Semiconductors reserves the right to change the specification in any manner without notice.
II	Preliminary data	Qualification	This data sheet contains data from the preliminary specification. Supplementary data will be published at a later date. Philips Semiconductors reserves the right to change the specification without notice, in order to improve the design and supply the best possible product.
III	Product data	Production	This data sheet contains data from the product specification. Philips Semiconductors reserves the right to make changes at any time in order to improve the design, manufacturing and supply. Relevant changes will be communicated via a Customer Product/Process Change Notification (CPCN).

## Notes

1. Please consult the most recently issued data sheet before initiating or completing a design.
2. The product status of the device(s) described in this data sheet may have changed since this data sheet was published. The latest information is available on the Internet at URL <http://www.semiconductors.philips.com>.
3. For data sheets describing multiple type numbers, the highest-level product status determines the data sheet status.

## DEFINITIONS

**Short-form specification** — The data in a short-form specification is extracted from a full data sheet with the same type number and title. For detailed information see the relevant data sheet or data handbook.

**Limiting values definition** — Limiting values given are in accordance with the Absolute Maximum Rating System (IEC 60134). Stress above one or more of the limiting values may cause permanent damage to the device. These are stress ratings only and operation of the device at these or at any other conditions above those given in the Characteristics sections of the specification is not implied. Exposure to limiting values for extended periods may affect device reliability.

**Application information** — Applications that are described herein for any of these products are for illustrative purposes only. Philips Semiconductors make no representation or warranty that such applications will be suitable for the specified use without further testing or modification.

## DISCLAIMERS

**Life support applications** — These products are not designed for use in life support appliances, devices, or systems where malfunction of these products can reasonably be expected to result in personal injury. Philips Semiconductors customers using or selling these products for use in such applications do so at their own risk and agree to fully indemnify Philips Semiconductors for any damages resulting from such application.

**Right to make changes** — Philips Semiconductors reserves the right to make changes in the products - including circuits, standard cells, and/or software - described or contained herein in order to improve design and/or performance. When the product is in full production (status 'Production'), relevant changes will be communicated via a Customer Product/Process Change Notification (CPCN). Philips Semiconductors assumes no responsibility or liability for the use of any of these products, conveys no licence or title under any patent, copyright, or mask work right to these products, and makes no representations or warranties that these products are free from patent, copyright, or mask work right infringement, unless otherwise specified.

# ***Philips Semiconductors – a worldwide company***

## **Contact information**

For additional information please visit <http://www.semiconductors.philips.com>. Fax: +31 40 27 24825

For sales offices addresses send e-mail to: [sales.addresses@www.semiconductors.philips.com](mailto:sales.addresses@www.semiconductors.philips.com).

© Koninklijke Philips Electronics N.V. 2003

SCA75

All rights are reserved. Reproduction in whole or in part is prohibited without the prior written consent of the copyright owner.

The information presented in this document does not form part of any quotation or contract, is believed to be accurate and reliable and may be changed without notice. No liability will be accepted by the publisher for any consequence of its use. Publication thereof does not convey nor imply any license under patent- or other industrial or intellectual property rights.

Printed in The Netherlands

R20/03/pp15

Date of release: 2003 Sep 08

Document order number: 9397 750 12018

*Let's make things better.*

**Philips  
Semiconductors**



**PHILIPS**

# Mouser Electronics

Authorized Distributor

Click to View Pricing, Inventory, Delivery & Lifecycle Information:

[NXP:](#)

[74ALVC244BQ-G](#) [74ALVC244D](#) [74ALVC244D-T](#) [74ALVC244PW](#) [74ALVC244PW-T](#)