

## Description

The AL5802 combines a high gain NPN transistor with a pre-biased NPN transistor to make a simple small footprint LED driver.

The LED current is set by an external resistor connected from REXT pin (6) to GND pin (4), the internal high gain transistor develops approximately 0.6V across the external resistor.

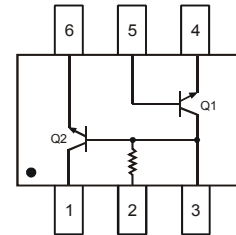
The AL5802 open-collector output can operate from 0.8V to 30V enabling it to operate from 5V to 24V power supplies without additional components.

PWM dimming of the LED current can be achieved by either driving the BIAS pin (2) with a low impedance voltage source, or driving the EN pin (3) with an external open-collector NPN transistor or open-drain N-channel MOSFET.

The AL5802 is available in a SOT26 package and is ideal for driving 20mA to 120mA LED currents.

## Pin Assignments

(Top View)



**SOT26**

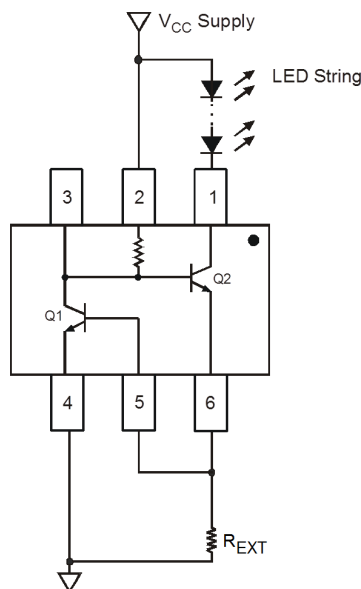
## Features

- Reference voltage VRSET = 0.65V
- -40 to +125°C temperature range
- 0.8V to 30V open-collector output
- Negative temperature co-efficient – automatically reduces the LED current at high temperatures
- Low thermal impedance SOT26 with copper leadframe
- **Totally Lead-Free & Fully RoHS Compliant (Notes 1 & 2)**
- **Halogen and Antimony Free. "Green" Device (Note 3)**
- **Qualified to AEC-Q101 Standards for High Reliability**

## Applications

- Linear LED driver
- LED signs
- Offline LED luminaries

## Typical Application Circuit

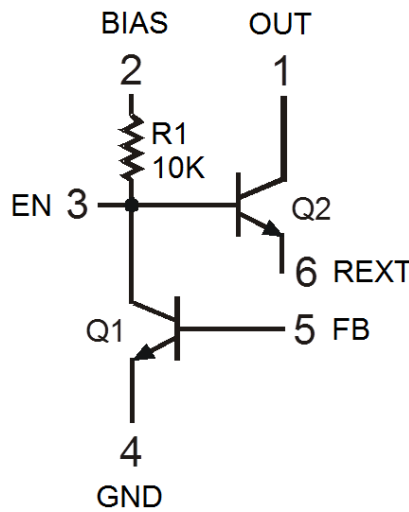


- Notes:
1. No purposely added lead. Fully EU Directive 2002/95/EC (RoHS) & 2011/65/EU (RoHS 2) compliant.
  2. See [http://www.diodes.com/quality/lead\\_free.html](http://www.diodes.com/quality/lead_free.html) for more information about Diodes Incorporated's definitions of Halogen- and Antimony-free, "Green" and Lead-free.
  3. Halogen- and Antimony-free "Green" products are defined as those which contain <900ppm bromine, <900ppm chlorine (<1500ppm total Br + Cl) and <1000ppm antimony compounds.

**Pin Descriptions**

Pin Number	Name	Function
1	OUT	Open-collector LED driver output
2	BIAS	Biases the open collector output transistor
3	EN	Enable pin for PWM dimming. Provides access to the base of Q2 and collector of Q1
4	GND	Ground reference point for setting LED current
5	FB	Feedback pin. Should be connected to pin 6.
6	REXT	Current sense pin. LED current sensing resistor should be connected from here to GND.

**Functional Block Diagram**



**Fig. 1 Block Diagram**

**Absolute Maximum Ratings**

Symbol	Characteristics	Values	Unit
$V_{OUT}$	Output voltage relative to GND	30	V
$V_{BIAS}$	BIAS voltage relative to GND (Note 4)	30	V
$V_{FB}$	LED voltage relative to GND	6	V
$V_{EN}$	EN voltage relative to GND	6	V
$V_{REXT}$	REXT voltage relative to GND	6	V
$I_{OUT}$	Output current	150	mA
$T_J$	Operating junction temperature	-40 to +150	°C
$T_{ST}$	Storage temperature	-55 to +150	°C

These are stress ratings only. Operation outside the absolute maximum ratings may cause device failure. Operation at the absolute maximum rating for extended periods may reduce device reliability.

Note: 4. With pins 5 and 6 connected together.

## Package Thermal Data

Characteristic	Symbol	Value	Unit
Power Dissipation (Note 5) @ $T_A = +25^\circ\text{C}$	$P_D$	0.37	W
Power Dissipation (Note 6) @ $T_A = +25^\circ\text{C}$		0.87	
Power Dissipation (Note 7) @ $T_A = +25^\circ\text{C}$		1	
Thermal Resistance, Junction to Ambient Air (Note 5) @ $T_A = +25^\circ\text{C}$	$R_{\theta JA}$	335	$^\circ\text{C/W}$
Thermal Resistance, Junction to Ambient Air (Note 6) @ $T_A = +25^\circ\text{C}$		143	
Thermal Resistance, Junction to Ambient Air (Note 7) @ $T_A = +25^\circ\text{C}$		120	

- Notes:
5. Device mounted on FR-4 PCB, 2oz with minimum recommended pad layout.
  6. Device mounted on 25mm x 25mm 2oz copper board.
  7. Device mounted on 50mm x 50mm 2oz copper board.

## Recommended Operating Conditions

Symbol	Parameter	Min	Max	Unit
$V_{BIAS}$	Supply voltage range	4.5	30	V
$V_{OUT}$	OUT voltage range	0.8	30	
$I_{LED}$	LED pin current (Note 8)	10	120	mA
$T_A$	Operating ambient temperature range	-40	+125	$^\circ\text{C}$

- Note: 8. Subject to ambient temperature, power dissipation and PCB.

## Electrical Characteristics – NPN Transistor – Q1 (@ $T_A = +25^\circ\text{C}$ , unless otherwise specified.)

Symbol	Characteristic	Test Condition	Min	Typ	Max	Unit
$V_{(BR)CEO}$	Collector-Emitter Breakdown Voltage (Note 9)	$I_C = 1.0\text{mA}, I_B = 0$	40	—	—	V
$V_{(BR)EBO}$	Emitter-Base Breakdown Voltage	$I_E = 10\mu\text{A}, I_C = 0$	6.0	—	—	V
$I_{CEX}$	Collector Cutoff Current	$V_{CE} = 30\text{V}, V_{EB(OFF)} = 3.0\text{V}$	—	—	50	nA
$I_{BL}$	Base Cutoff Current	$V_{CE} = 30\text{V}, V_{EB(OFF)} = 3.0\text{V}$	—	—	50	nA
$h_{FE}$	DC Current Gain	$I_C = 100\mu\text{A}, V_{CE} = 1.0\text{V}$	40	—	—	—
		$I_C = 1.0\text{mA}, V_{CE} = 1.0\text{V}$	70	—	—	
		$I_C = 10\text{mA}, V_{CE} = 1.0\text{V}$	100	—	300	
$V_{CE(SAT)}$	Collector-Emitter Saturation Voltage (Note 9)	$I_C = 10\text{mA}, I_B = 1.0\text{mA}$	—	—	0.20	V
$V_{BE(SAT)}$	Base-Emitter Saturation Voltage	$I_C = 10\text{mA}, I_B = 1.0\text{mA}$	0.65	—	0.85	V

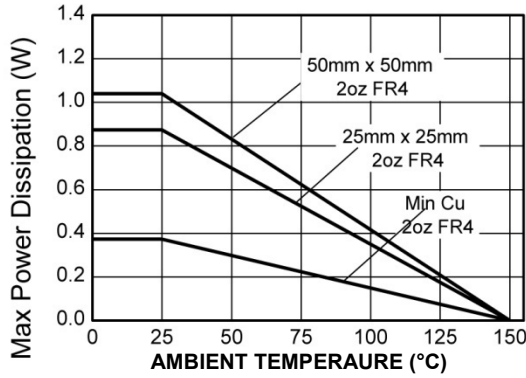
## Electrical Characteristics – NPN Pre-biased Transistor – Q2 (@ $T_A = +25^\circ\text{C}$ , unless otherwise specified.)

Symbol	Characteristic	Test Condition	Min	Typ	Max	Unit
$V_{(BR)CBO}$	Collector-Base Breakdown Voltage	$I_C = 50\mu\text{A}, I_E = 0$	30	—	—	V
$V_{(BR)CEO}$	Collector-Emitter Breakdown Voltage (Note 9)	$I_C = 1\text{mA}, I_B = 0$	30	—	—	V
$V_{(BR)EBO}$	Emitter-Base Breakdown Voltage	$I_E = 50\mu\text{A}, I_C = 0$	5.0	—	—	V
$I_{CBO}$	Collector Cut-Off Current	$V_{CB} = 30\text{V}, I_E = 0$	—	—	0.5	$\mu\text{A}$
$I_{EBO}$	Emitter Cut-Off Current	$V_{EB} = 4\text{V}, I_C = 0$	—	—	0.5	$\mu\text{A}$
$V_{CE(SAT)}$	Collector-Emitter Saturation Voltage (Note 9)	$I_C = 10\text{mA}, I_B = 1\text{mA}$	—	—	0.3	V
$h_{FE}$	DC Current Gain (Note 9)	$V_{CE} = 5\text{V}, I_C = 150\text{mA}$	100	—	—	—
$R_1$	Input Resistance	—	7	10	13	k $\Omega$

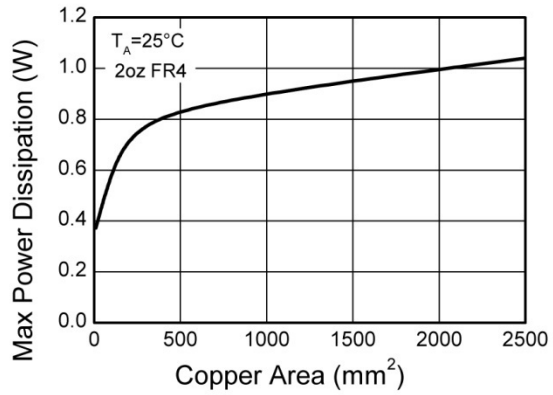
\*Characteristics of transistor only.

- Note: 9. Short duration pulse test used to minimize self-heating effect.

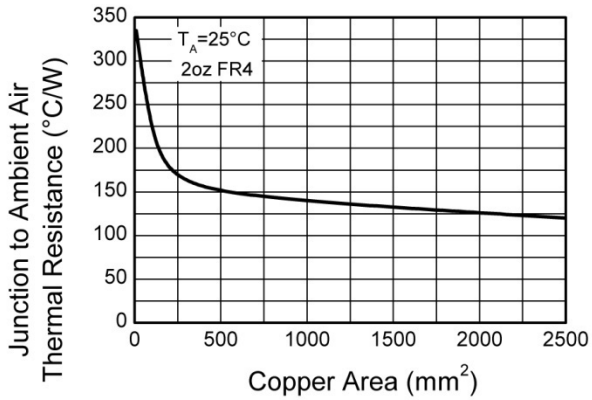
**Thermal Characteristics**



**Fig. 2 Derating Curve**

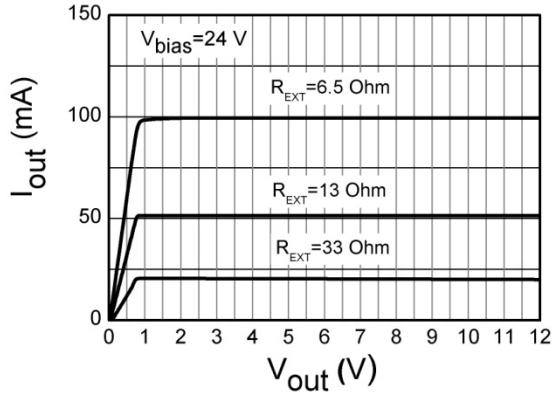


**Fig. 3 Max Power vs. Area**

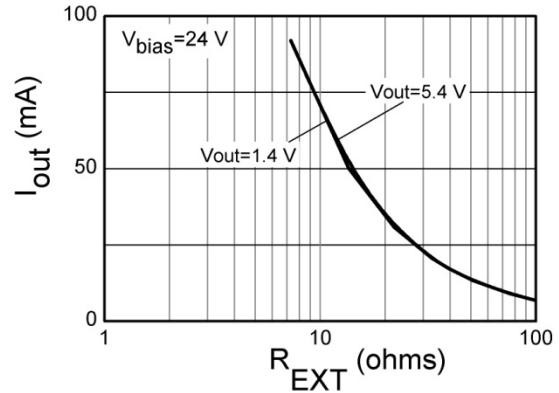


**Fig. 4 Thermal Resistance vs. Area**

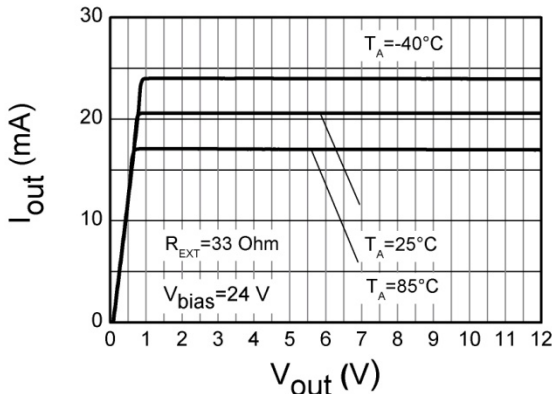
**Typical Performance Characteristics**



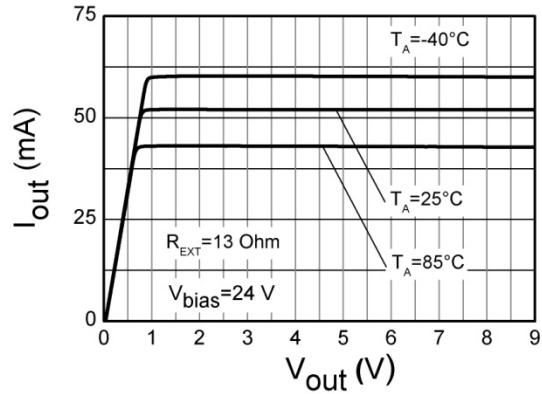
**Fig. 5 Output Current vs.  $V_{out}$**



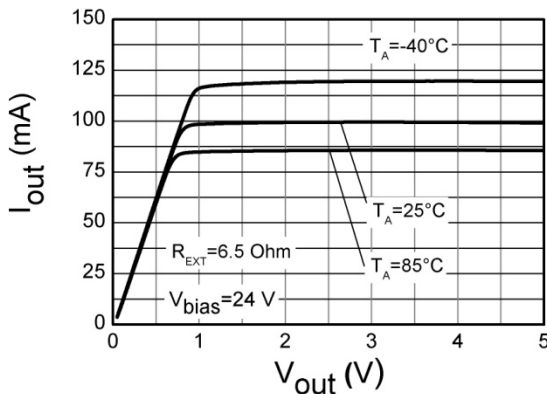
**Fig. 6 Output Current vs.  $R_{EXT}$**



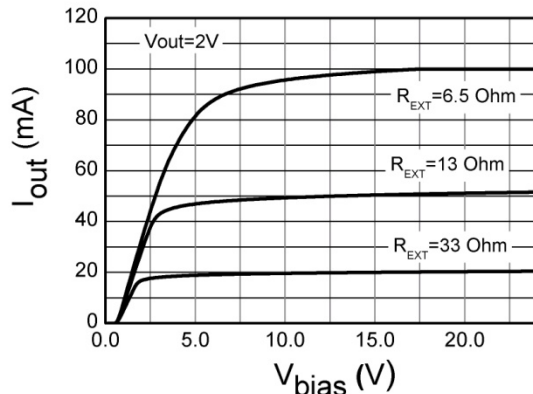
**Fig. 7 Output Current vs.  $V_{out}$**



**Fig. 8 Output Current vs.  $V_{out}$**



**Fig. 9 Output Current vs.  $V_{out}$**



**Fig. 10 Output Current vs.  $V_{bias}$**

Note: 10.  $V_{out}$  in the "Output current Vs  $V_{out}$ " graphs limited by power dissipation in the device.

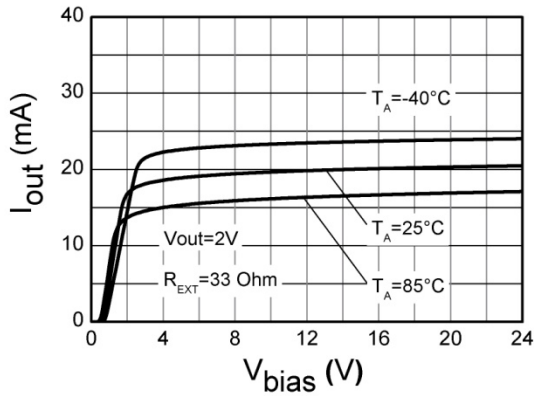


Fig. 11 Output Current vs. V<sub>bias</sub>

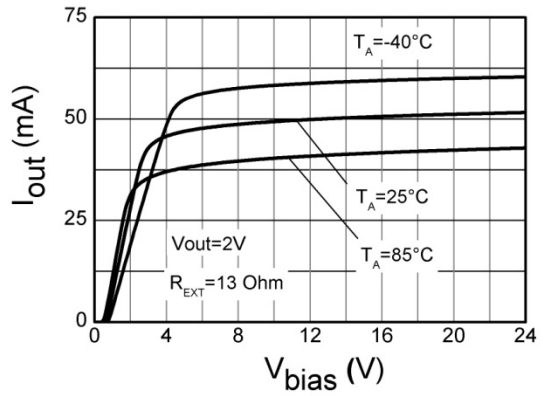


Fig. 12 Output Current vs. V<sub>bias</sub>

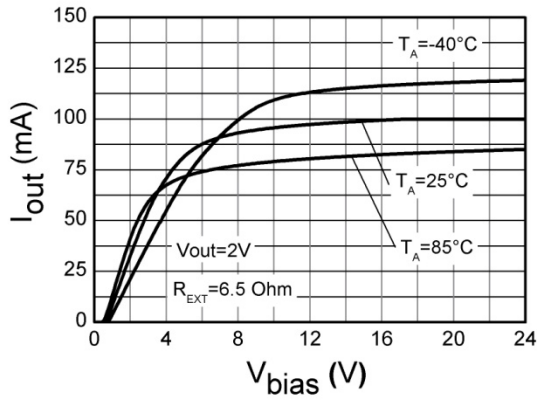


Fig. 13 Output Current vs. V<sub>bias</sub>

**Application Information**

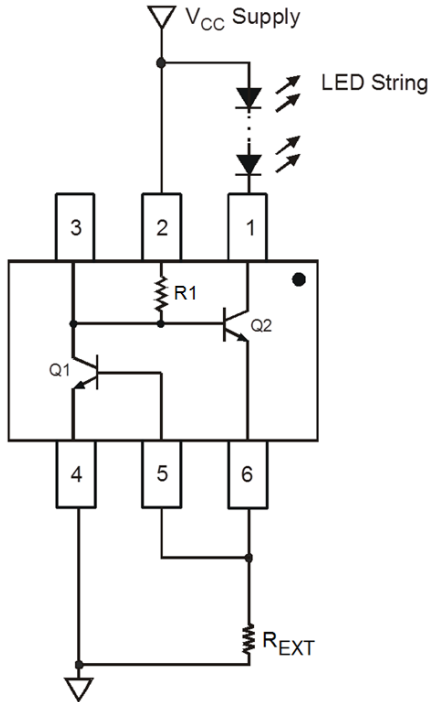


Fig. 14 Typical Application Circuit for Linear Mode Current Sink LED Driver

The AL5802 has been designed for driving low current LEDs with typical LED current of 20mA to 100mA. It provides a cost effective way for driving low current LEDs compared with more complex switching regulator solutions. Furthermore, it reduces the PCB board area of the solution as there is no need for external components like inductors, capacitors and switching diodes.

Figure 14 shows a typical application circuit diagram for driving an LED or string of LEDs. The NPN transistor Q1 measures the LED current by sensing the voltage across an external resistor  $R_{EXT}$ . Q1 uses its  $V_{BE}$  as reference to set the voltage across  $R_{EXT}$  and controls the base current into Q2. Q2 operates in linear mode to regulate the LED current. The LED current is

$$I_{LED} = V_{BE(Q1)} / R_{EXT}$$

From this, for any required LED current the necessary external resistor  $R_{EXT}$  can be calculated from

$$R_{EXT} = V_{BE(Q1)} / I_{LED}$$

Two or more AL5802 can be connected in parallel to construct higher current LED strings as shown in Figure 15.

Consideration of the expected linear mode power dissipation must be factored into the design, with respect to the AL5802's thermal resistance. The maximum voltage across the device can be calculated by taking the maximum supply voltage less the voltage across the LED string.

$$V_{CE(Q2)} = V_{CC} - V_{LED} - V_{BE(Q1)}$$

$$P_D = V_{CE(Q2)} * I_{LED} + (V_{CC} - V_{BE(Q2)} - V_{BE(Q1)})^2 / R_1$$

As the output current of AL5802 increases, it is necessary to provide appropriate thermal relief to the device. The power dissipation supported by the device is dependent upon the PCB board material, the copper area and the ambient temperature. The maximum dissipation the device can handle is given by:

$$P_D = (T_{J(MAX)} - T_A) / R_{\theta JA}$$

Refer to the thermal characteristic graphs on page 4 for selecting the appropriate PCB copper area.

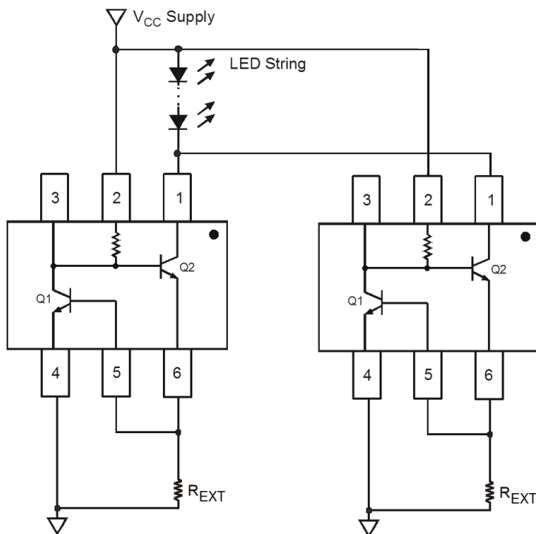


Fig. 15 Application Circuit for Increasing LED Current

PWM dimming can be achieved by driving the EN pin. An external open-collector NPN transistor or open-drain N-channel MOSFET can be used to drive the EN pin as shown in Figure 16. Dimming is achieved by turning the LEDs ON and OFF for a portion of a single cycle. The PWM signal can be provided by a micro-controller or analog circuitry. Figure 17 is a typical response of LED current vs. PWM duty cycle on the EN pin.

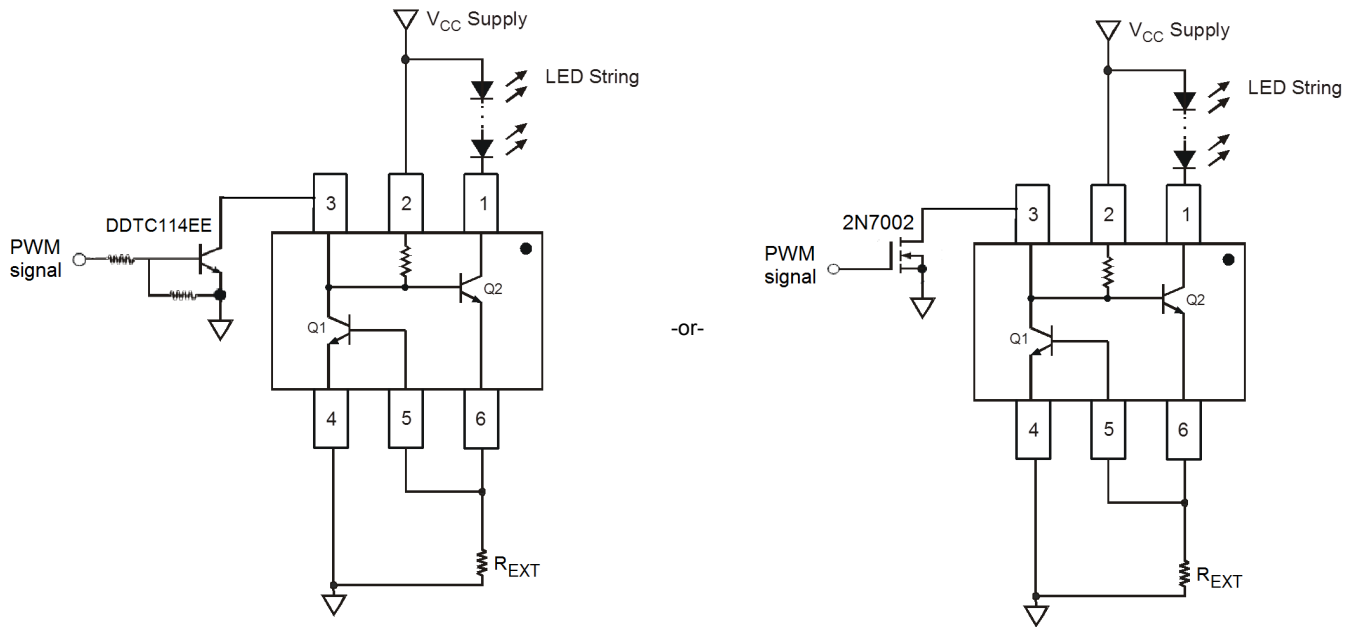


Fig. 16 Application Circuits for LED Driver with PWM Dimming Functionality

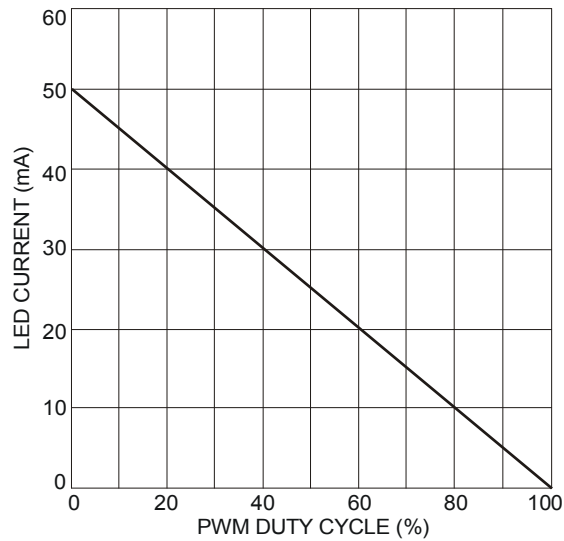


Fig. 17 Typical LED current response vs. PWM duty cycle for  $R_{EXT} = 13\Omega$  at 400Hz PWM frequency



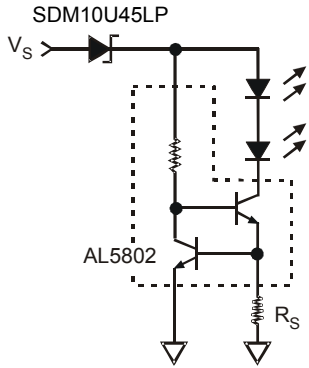


Fig. 18 Application circuit for LED driver with reverse polarity protection

To remove the potential of incorrect connection of the power supply damaging the lamp's LEDs, many systems use some form of reverse polarity protection.

One solution for reverse input polarity protection is to simply use a diode with a low  $V_F$  in-line with the driver/LED combination. The low  $V_F$  increases the available voltage to the LED stack and dissipates less power. A circuit example is presented in Fig. 18 using Diodes Inc. SBR® (Super Barrier Rectifier) technology. An SDM10U45LP (0.1A/45V) is shown, providing exceptionally low  $V_F$  for its package size of 1mm x 0.6mm, equivalent to an 0402 chip style package. Other reverse voltage ratings are also available in Diodes' website such as the SBR02U100LP (0.2A/100V) or SBR0220LP (0.2A/20V).

Automotive applications commonly use this method for reverse battery protection.

A second approach, shown in Fig. 19, improves upon the method shown in Fig. 18. Whereas the method in Fig. 18 protects the light engine, it will not function until the problem has been diagnosed and corrected.

The method shown in Fig. 19 not only provides reverse polarity protection, it also corrects the reversed polarity, allowing the light engine to function.

The BAS40BRW incorporates four low  $V_F$ , Schottky diodes into a single package and allows more voltage available for the LED stack and dissipates less power than standard rectifier bridges.

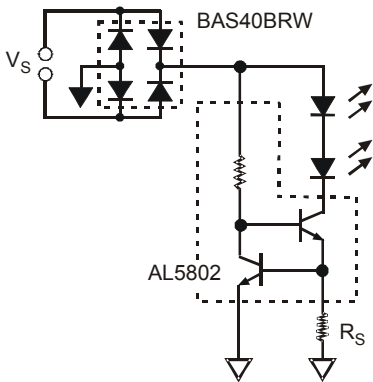


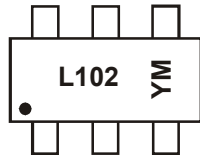
Fig. 19 Application circuit for LED driver with assured operation regardless of polarity

**Ordering Information** (Note 11)

Device	Qualification	Packaging	Tape and Reel	
			Quantity	Part Number Suffix
AL5802	Commercial	SOT26	3,000/Tape & Reel	-7
AL5802	Commercial	SOT26	10,000/Tape & Reel	-13

Note: 11. For packaging details, go to our website at <http://www.diodes.com/products/packages.html>.

**Marking Information**



L102 = Product Type Marking Code  
 YM = Date Code Marking  
 Y = Year (ex: B = 2014)  
 M = Month (ex: 9 = September)

Date Code Key

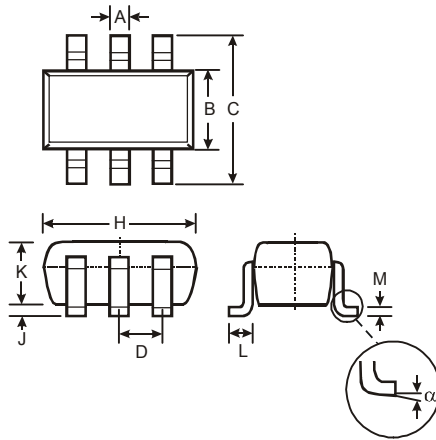
Year	2011	2012	2013	2014	2015	2016	2017	2018	2019
Code	Y	Z	A	B	C	D	E	F	G

Month	Jan	Feb	Mar	Apr	May	Jun	Jul	Aug	Sep	Oct	Nov	Dec
Code	1	2	3	4	5	6	7	8	9	O	N	D

**Package Outline Dimensions**

Please see AP02002 at <http://www.diodes.com/datasheets/ap02002.pdf> for latest version.

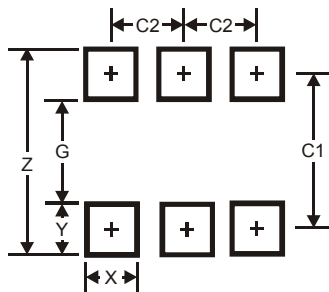


SOT26			
Dim	Min	Max	Typ
A	0.35	0.50	0.38
B	1.50	1.70	1.60
C	2.70	3.00	2.80
D	—	—	0.95
H	2.90	3.10	3.00
J	0.013	0.10	0.05
K	1.00	1.30	1.10
L	0.35	0.55	0.40
M	0.10	0.20	0.15
α	0°	8°	—

All Dimensions in mm

**Suggested Pad Layout**

Please see AP02001 at <http://www.diodes.com/datasheets/ap02001.pdf> for the latest version.



Dimensions	Value (in mm)
Z	3.20
G	1.60
X	0.55
Y	0.80
C1	2.40
C2	0.95

### IMPORTANT NOTICE

DIODES INCORPORATED MAKES NO WARRANTY OF ANY KIND, EXPRESS OR IMPLIED, WITH REGARDS TO THIS DOCUMENT, INCLUDING, BUT NOT LIMITED TO, THE IMPLIED WARRANTIES OF MERCHANTABILITY AND FITNESS FOR A PARTICULAR PURPOSE (AND THEIR EQUIVALENTS UNDER THE LAWS OF ANY JURISDICTION).

Diodes Incorporated and its subsidiaries reserve the right to make modifications, enhancements, improvements, corrections or other changes without further notice to this document and any product described herein. Diodes Incorporated does not assume any liability arising out of the application or use of this document or any product described herein; neither does Diodes Incorporated convey any license under its patent or trademark rights, nor the rights of others. Any Customer or user of this document or products described herein in such applications shall assume all risks of such use and will agree to hold Diodes Incorporated and all the companies whose products are represented on Diodes Incorporated website, harmless against all damages.

Diodes Incorporated does not warrant or accept any liability whatsoever in respect of any products purchased through unauthorized sales channel.

Should Customers purchase or use Diodes Incorporated products for any unintended or unauthorized application, Customers shall indemnify and hold Diodes Incorporated and its representatives harmless against all claims, damages, expenses, and attorney fees arising out of, directly or indirectly, any claim of personal injury or death associated with such unintended or unauthorized application.

Products described herein may be covered by one or more United States, international or foreign patents pending. Product names and markings noted herein may also be covered by one or more United States, international or foreign trademarks.

This document is written in English but may be translated into multiple languages for reference. Only the English version of this document is the final and determinative format released by Diodes Incorporated.

### LIFE SUPPORT

Diodes Incorporated products are specifically not authorized for use as critical components in life support devices or systems without the express written approval of the Chief Executive Officer of Diodes Incorporated. As used herein:

A. Life support devices or systems are devices or systems which:

1. are intended to implant into the body, or
2. support or sustain life and whose failure to perform when properly used in accordance with instructions for use provided in the labeling can be reasonably expected to result in significant injury to the user.

B. A critical component is any component in a life support device or system whose failure to perform can be reasonably expected to cause the failure of the life support device or to affect its safety or effectiveness.

Customers represent that they have all necessary expertise in the safety and regulatory ramifications of their life support devices or systems, and acknowledge and agree that they are solely responsible for all legal, regulatory and safety-related requirements concerning their products and any use of Diodes Incorporated products in such safety-critical, life support devices or systems, notwithstanding any devices- or systems-related information or support that may be provided by Diodes Incorporated. Further, Customers must fully indemnify Diodes Incorporated and its representatives against any damages arising out of the use of Diodes Incorporated products in such safety-critical, life support devices or systems.

Copyright © 2014, Diodes Incorporated

[www.diodes.com](http://www.diodes.com)