

Diode Power Module

- Inside fast free-wheeling diode
- Package with insulated metal base plate
- Diode especially for brake choppers
- matched with BSM 300 GA 170 DN 2

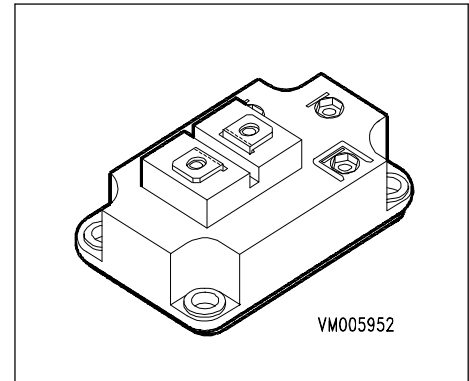

Type	V_{R25}	I_{FDC}	Package	Ordering Code
BYM 300 A 170 DN2	1700V	380A	SINGLE DIODE 1	C67070-A2901-A67

Maximum Ratings

Parameter	Symbol	Values	Unit
Diode reverse voltage $T_j = 25\text{ °C}$	V_{R25}	1700	V
DC current $T_C = 25\text{ °C}$ $T_C = 80\text{ °C}$	I_{FDC}	380 250	A
Pulsed diode current, $t_p = 1\text{ ms}$ $T_C = 25\text{ °C}$ $T_C = 80\text{ °C}$	I_{Fpuls}	760 500	
$i^2 t$ -value, Diode, $t_p = 10\text{ ms}$, $T_j = 150\text{ °C}$	$\dot{a}^2 t$	42050	A ² s
Power dissipation per Diode	P_D	830	W
Chip temperature	T_j	+ 150	°C
Storage temperature	T_{stg}	-40 ... + 125	
Thermal resistance, chip case	R_{thJC}	≤ 0.17	K/W
Insulation test voltage, $t = 1\text{ min.}$	V_{is}	4000	Vac
Creepage distance	-	20	mm
Clearance	-	11	
DIN humidity category, DIN 40 040	-	F	sec
IEC climatic category, DIN IEC 68-1	-	40 / 125 / 56	

Electrical Characteristics, at $T_j = 25\text{ °C}$, unless otherwise specified

Parameter	Symbol	Values			Unit
		min.	typ.	max.	
Free-Wheel Diodes					
Diode forward voltage $I_F = 300\text{ A}$, $V_{GE} = 0\text{ V}$, $T_j = 25\text{ °C}$ $I_F = 300\text{ A}$, $V_{GE} = 0\text{ V}$, $T_j = 125\text{ °C}$	V_F	-	2.3 2.1	2.8 -	V
Reverse current $V_{CA} = 1700\text{ V}$, $T_j = 25\text{ °C}$ $V_{CA} = 1700\text{ V}$, $T_j = 125\text{ °C}$	I_R	-	0.5 2	0.8 -	mA
Reverse recovery time $I_F = 300\text{ A}$, $V_R = -1200\text{ V}$, $V_{GE} = 0\text{ V}$ $di_F/dt = -1500\text{ A}/\mu\text{s}$, $T_j = 125\text{ °C}$	t_{rr}	-	1	-	μs
Reverse recovery charge $I_F = 300\text{ A}$, $V_R = -1200\text{ V}$, $V_{GE} = 0\text{ V}$ $di_F/dt = -1500\text{ A}/\mu\text{s}$ $T_j = 25\text{ °C}$ $T_j = 125\text{ °C}$	Q_{rr}	-	22 70	- -	μC

Power dissipation

$P_{tot} = f(T_C)$

parameter: $T_j \leq 150\text{ }^\circ\text{C}$

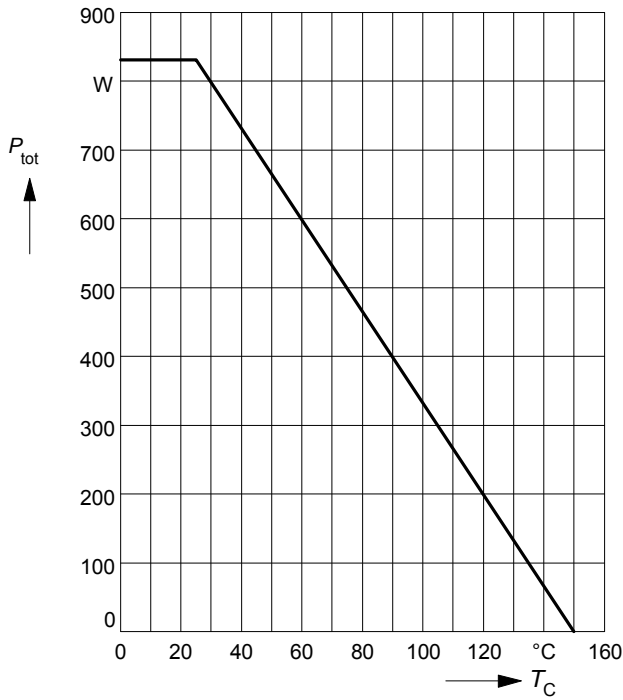

Transient thermal impedance Diode

$Z_{thJC} = f(t_p)$

parameter: $D = t_p / T$

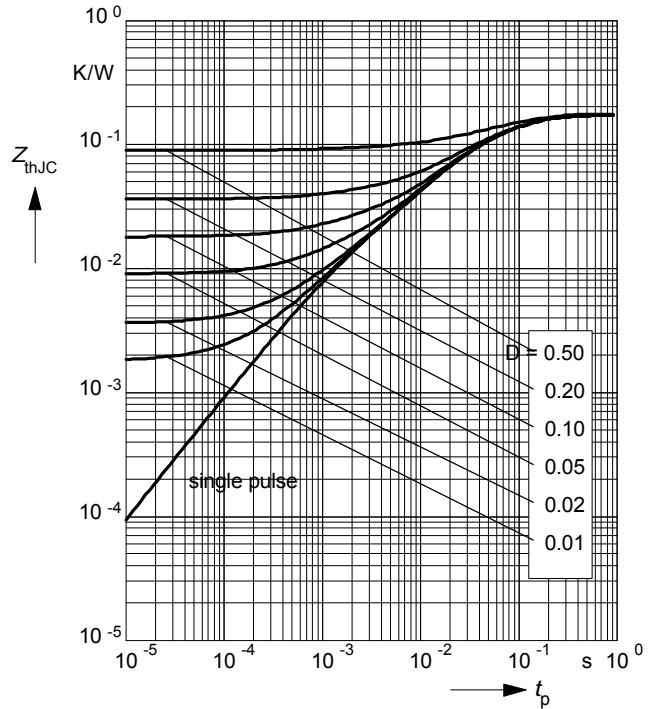

Forward characteristics of fast recovery reverse diode $I_F = f(V_F)$

parameter: T_j

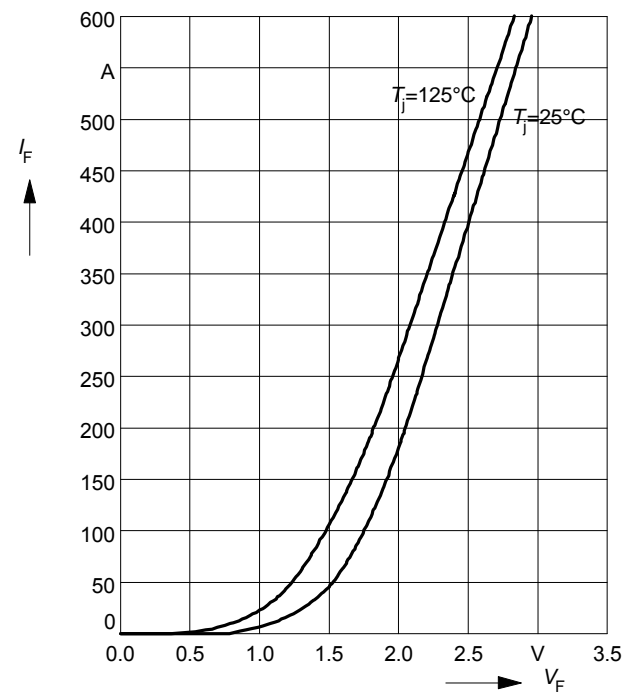

Circuit Diagram

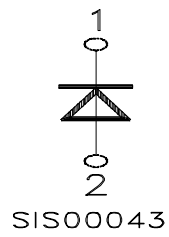

Package Outlines

Dimensions in mm

Weight: 420 g

