

NOIS1SM0250A

STAR250 250K Pixel Radiation Tolerant CMOS Image Sensor

Features

- 512 x 512 Active Pixels
- 25 μm Pixel Size
- 1 inch Optical Format
- Up to 30 Frames per Second (fps) at Full Resolution
- 8 MHz Maximum Data Rate/Master Clock
- 3340 $\text{V}\cdot\text{m}^2/\text{W}\cdot\text{s}$ Sensitivity
- 74 dB (5000:1) Dynamic Range
- 76 e^- kTC Noise
- 4750 e^-/s at RT Dark Current
- 5 V Supply Voltage
- Operating Temperature Range
 - ◆ -40°C to $+85^\circ\text{C}$
- Gamma Total Dose Radiation Tolerance:
 - ◆ Increase in Average Dark Current $< 1 \text{ nA}/\text{cm}^2$ after 3 MRad
 - ◆ Image Operation with Dark Signal $< 1 \text{ V}/s$ after 10 Mrad Demonstrated (Co60)
- Proton Radiation Tolerance:
 - ◆ 1% of Pixels has an Increase in Dark Current $> 1 \text{ nA}/\text{cm}^2$ after $3 \cdot 10^{10}$ Protons at 11.7 MeV
- SEL Threshold $> 80 \text{ MeV cm}^3 \text{ mg}^{-1}$
- Less than 350 mW Power Consumption
- These Devices are Pb-Free and are RoHS Compliant

Overview

The STAR250 sensor is a CMOS active pixel sensor featuring 512 x 512 pixels on a 25 mm pitch, on chip fixed pattern noise (FPN) correction, a programmable gain amplifier, and a 10-bit ADC. Flexible operating (multiple windowing, sub-sampling) is possible by direct addressable X and Y registers.

The sensor has an outstanding radiation tolerance that is observed using proprietary technology modifications and design techniques. The STAR250 utilizes a BK7G18 glass lid with anti reflective coating. The cavity is filled with N_2 increasing the temperature operating range.

ORDERING INFORMATION

| Marketing Part Number | Description | Package |
|-----------------------|------------------------|------------------------|
| NOIS1SM0250A-HHC | Mono with BK7G18 glass | 84-pin JLCC case 114AK |
| NOIS1SM0250A-WWC | Mono wafer | Wafer Sales |

NOTE: Refer to Ordering Code Definition on page 2 for more information.



ON Semiconductor®

www.onsemi.com

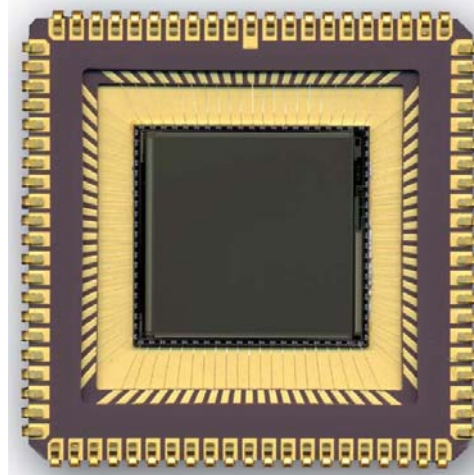

Figure 1. STAR250 Photograph

JLCC84
CASE 114AK

Applications

- Applications Requiring Higher Pixel Pitch
- Scientific Applications Requiring Radiation Tolerance
- Nuclear Inspection

NOIS1SM0250A

ORDERING CODE DEFINITION

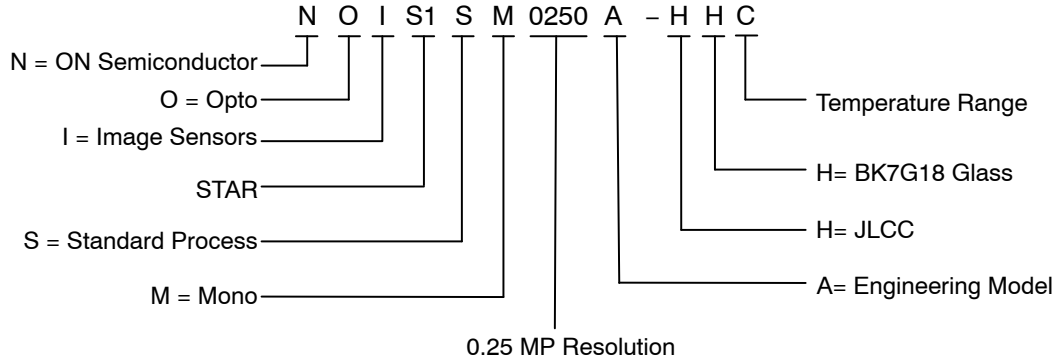

Marking

The marking shall consist of a lead identification and traceability information.

Lead Identification

An index to pin 1 shall be located on the top of the package as shown in section Package Dimensions on page 21. The pin numbering is counter clock-wise, when looking at the top-side of the component.

Traceability Information Tests

Each component shall be marked such that complete traceability can be maintained.

The component shall bear a number that is constituted as follows:

| Orderable Part Number | Package Mark: Line 1 | Package Mark: Line 2 | Package Mark: Line 3 |
|--|----------------------|----------------------|----------------------|
| NOIS1SM0250A-HHC | NOIS1SM0250A | -HHC_NNNN | AWLYYWW |
| where NNNN- serialized number controlled manually by ON Semiconductor, BELGIUM | | | |
| where AWLYYWW represents the lot assembly date | | | |

MARKING DIAGRAM

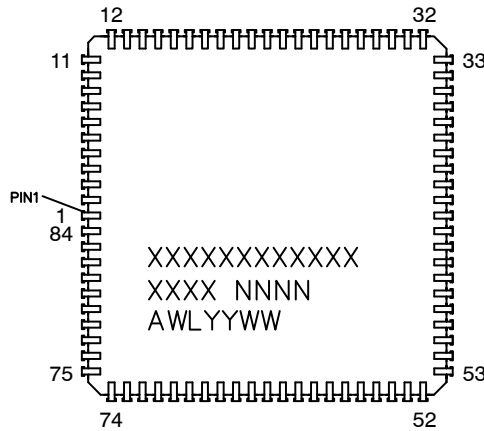

XXXXX = Specific Device Code
 A = Assembly Location
 WL = Wafer Lot
 YY = Year
 WW = Work Week
 NNNN = Serial Number

NOIS1SM0250A

SPECIFICATIONS

Table 1. GENERAL SPECIFICATIONS

| Parameter | Specification | Remarks |
|-------------------------------|---|---|
| Pixel architecture | 3 transistor active pixel 4 diodes per pixel | Radiation-tolerant pixel design 4 photodiodes for improved MTF |
| Pixel size | 25 x 25 μm^2 | |
| Resolution | 512 x 512 pixels | |
| Pixel rate | 8 Mps | |
| Shutter type | Electronic | Integration time is variable, steps equal to the row readout time |
| Frame rate | 29 full frames/second | |
| Extended dynamic range | Double slope | |
| Programmable gain | Programmable between x1, x2, x4, x8 | Selectable through pins G0 and G1 |
| Supply voltage V_{DD} | 5 V | |
| Operational temperature range | -40°C to +85°C | Nitrogen in cavity |
| Package | 84-pin JLCC | |

Table 2. ELECTRO-OPTICAL SPECIFICATIONS

| Parameter | Specification (Typical) | Comment |
|-------------------------------------|--|--|
| Detector technology | CMOS active pixel sensor | |
| Pixel structure | 3-transistor active pixel 4 diodes per pixel | Radiation-tolerant pixel design 4 photodiodes for improved MTF |
| Photodiode | High fill factor photodiode | |
| Sensitive area format | 512 by 512 pixels | |
| Pixel size | 25 μm^2 x 25 μm^2 | |
| Spectral range | 200 nm to 1000 nm | See Figure 2 and Figure 3 |
| Quantum efficiency x fill factor | Maximum 35% | Above 20% between 450 nm and 750 nm (Metal FillFactor (MFF) is 63%) |
| Full well capacity | 311K electrons | When output amplifier gain = 1 |
| Linear range within +1% | 128K electrons | When output amplifier gain = 1 |
| Output signal swing | 1.68 V | When output amplifier gain = 1 |
| Conversion gain | 5.7 $\mu\text{V}/e^-$ | When output amplifier gain = 1 near dark |
| Temporal noise | 76 e^- | Dominated by kTC |
| Dynamic range | 74 dB (5000:1) | At the analog output |
| FPN | 1 < 0.1% of full well (typical) | Measured local, on central image area 50% of pixels in the dark |
| PRNU (photo response nonuniformity) | Local: 1 = 0.39% of response Global: 1 = 1.3% of response | Measured in central image area 50% of pixels, at Qsat/2 |
| Average dark current signal | 4750 e^-/s | At RT |
| DSNU (dark signal nonuniformity) | 3805 e^-/s RMS | At RT, scale linearly with integration time |
| MTF | Horizontal: 0.36 Vertical: 0.39 | at 600 nm. |
| Optical cross talk | 5% to nearest neighbor if central pixel is homogeneously illuminated | |

NOIS1SM0250A

Table 2. ELECTRO-OPTICAL SPECIFICATIONS

| Parameter | Specification (Typical) | Comment |
|--------------------------|--|--|
| Antiblooming capacity | x 1000 to x 100 000 | |
| Output amplifier gain | 1, 2, 4, or 8 | Controlled by two bits |
| Windowing | X and Y 9-bit programmable shift registers | Indicate upper left pixel of each window |
| Electronic shutter range | 1: 512 | Integration time is variable in time steps equal to the row readout time |
| ADC | 10-bit | |
| ADC linearity | ±3.5 counts | INL |
| Missing codes | none | |
| ADC setup time | 310 ns | To reach 99% of final value |
| ADC delay time | 125 ns | |
| Power dissipation | < 350 mW | Average at 8 MHz pixel rate |

Spectral Response Curve

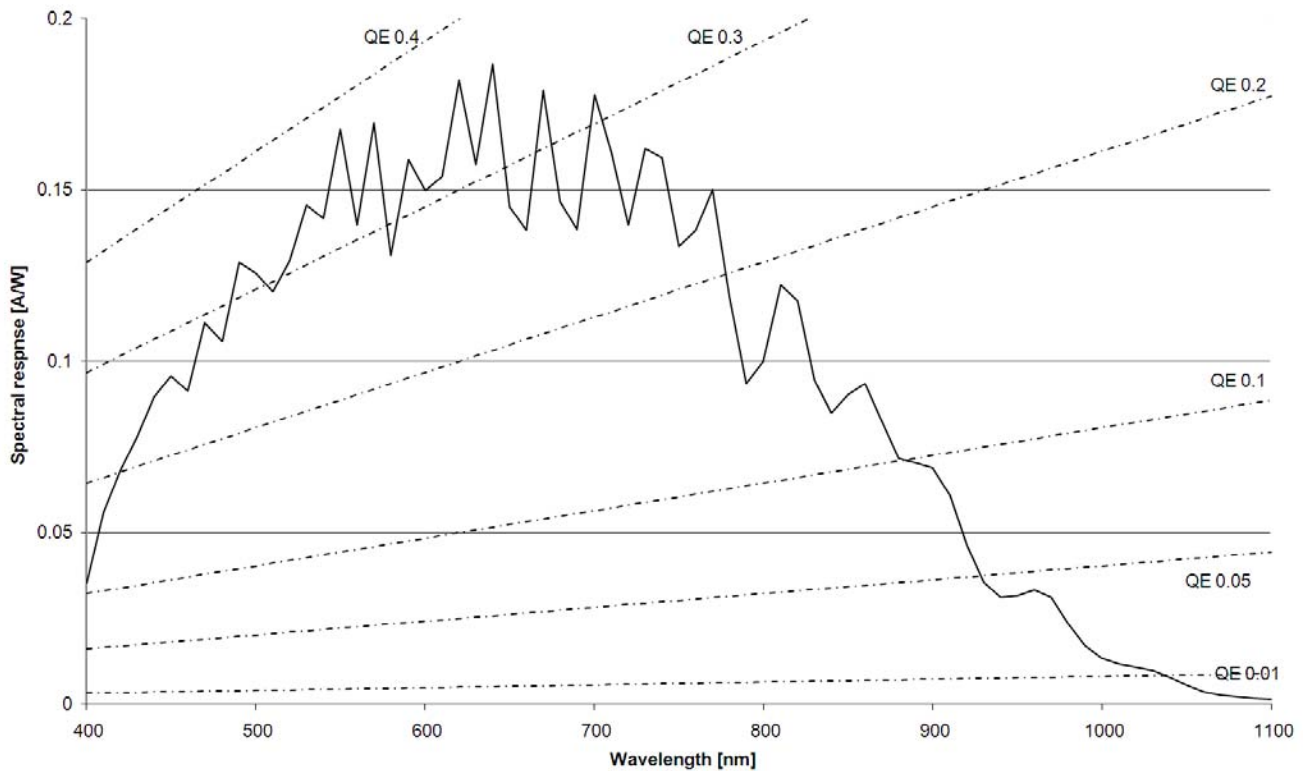

Figure 2. Spectral Response Curve

NOIS1SM0250A

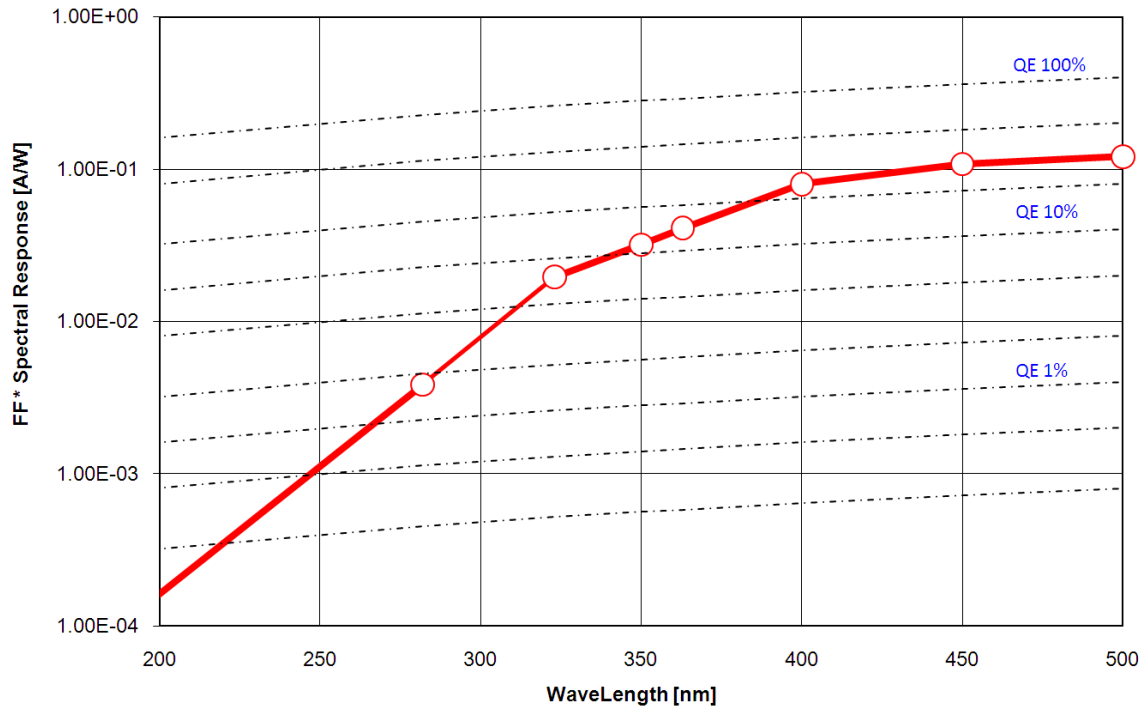

Figure 3. UV Region Spectral Response Curve

Pixel Profile

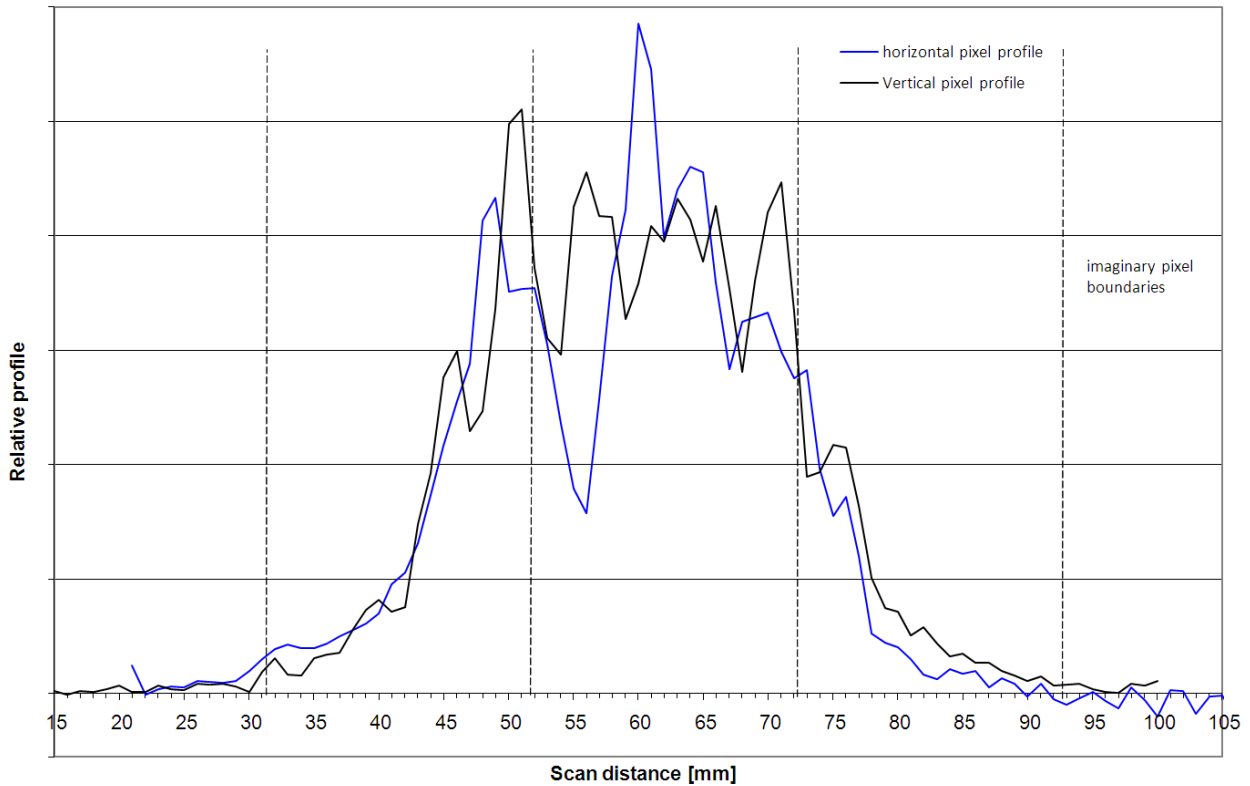

Figure 4. Pixel Profile

The pixel profile is measured using the ‘knife edge’ method: the image of a target containing a black to white transition is scanned over a certain pixel with subpixel resolution steps. The sensor settings and illumination

conditions are adjusted such that the transition covers 50% of the output range. The scan is performed both horizontal and vertical.

NOIS1SM0250A

Electrical Specifications

Absolute Maximum Ratings

Absolute ratings are those values beyond which damage to the device may occur.

Table 3. ABSOLUTE MAXIMUM RATINGS STAR250BK7

| Characteristics | Limits | | Units | Remarks |
|-------------------------------|--------|----------------|-------|--|
| | Min | Max | | |
| Any supply voltage | -0.5 | +7 | V | |
| Voltage on any input terminal | -0.5 | $V_{DD} + 0.5$ | V | |
| Storage temperature | -40 | +85 | °C | |
| | -40 | +120 | °C | Maximum 1 hour |
| Sensor soldering temperature | NA | 125 | °C | Hand soldering only. The sensor's temperature during soldering should not exceed this limit. |

Stresses exceeding those listed in the Maximum Ratings table may damage the device. If any of these limits are exceeded, device functionality should not be assumed, damage may occur and reliability may be affected.

Table 4. RADIATION TOLERANCE

| Parameter | Criterion | Qualification level |
|--------------------------------------|--|-----------------------------|
| Gamma total dose radiation tolerance | Increase in average dark current < 1 nA/cm ² after 3 MRad | See Figure 5 |
| | Image operation with dark signal < 1V/s | 10 Mrad demonstrated (Co60) |
| | Single (test) pixel operation with dark signal < 1V/s | 24 Mrad demonstrated (Co60) |
| Proton radiation tolerance | 1% of pixels has an increase in dark current > 1 nA/cm ² after 3×10^{10} protons at 11.7 MeV | See Figure 5 |
| SEL threshold | > 80 MeV cm ³ mg ⁻¹ | To be confirmed |

NOIS1SM0250A

Figure 5 shows the increase in dark current under total dose irradiation. This curve is measured when the radiation is at high dose rate. Annealing results in a significant dark current decrease.

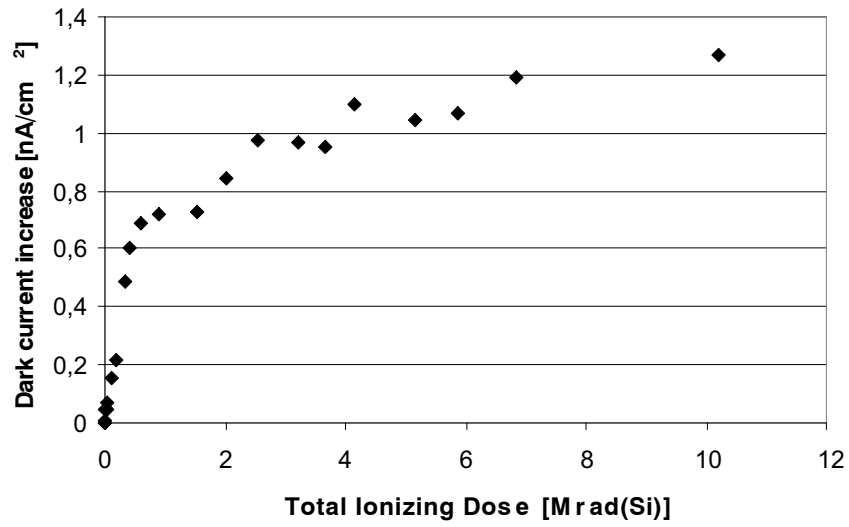

Figure 5. Dark Current Increase

Figure 6 shows the percentage of pixels with a dark current increase under 11.7 MeV radiation with protons.

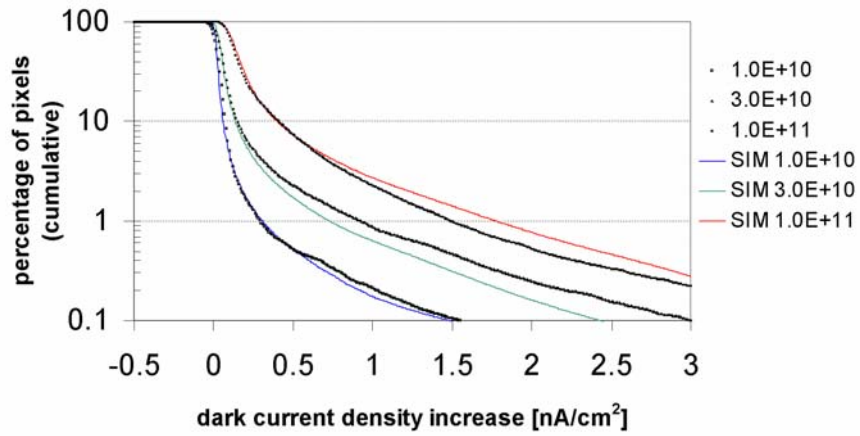

Figure 6. Percentage of Pixels with Dark Current Increase

NOIS1SM0250A

DC Operating Conditions

Table 5. DC SPECIFICATIONS

| Symbol | Parameter (Notes 1, 2 and 3) | Min | Typ | Max | Units |
|-------------------------------|--|------|----------|-----------------|-------|
| V _{DD_ANA} | Analog supply voltage to imager part | – | 5 | – | V |
| V _{DD_DIG} | Digital supply voltage to imager part | – | 5 | – | V |
| V _{DD_ADC_ANA} | Analog supply voltage to ADC | – | 5 | – | V |
| V _{DD_ADC_DIG} | Digital supply voltage to ADC | – | 5 | – | V |
| V _{DD_ADC_DIG_3.3/5} | Supply voltage of ADC output stage | – | 3.3 to 5 | – | V |
| V _{IH} | Logical '1' input voltage | 2.3 | – | V _{DD} | V |
| V _{IL} | Logical '0' input voltage | 0 | – | 1 | V |
| V _{OH} | Logical '1' output voltage | 4.25 | 4.5 | – | V |
| V _{OL} | Logical '0' output voltage | – | 0.1 | 1 | V |
| V _{DD_PIX} | Pixel array power supply (default 5 V, the device is then in 'soft reset'. To avoid the image lag associated with soft reset, reduce this voltage to 3–3.5 V 'hard reset') | – | 5 | – | V |
| V _{DD_RESL} | Reset power supply | – | 5 | – | V |

1. All parameters are characterized for DC conditions after establishing thermal equilibrium.
2. Unused inputs must always be tied to an appropriate logic level, for example, either V_{DD} or GND.
3. This device contains circuitry to protect the inputs against damage due to high static voltages or electric fields. Take normal precautions to avoid applying any voltages higher than the maximum rated voltages to this high impedance circuit.

NOIS1SM0250A

SENSOR ARCHITECTURE

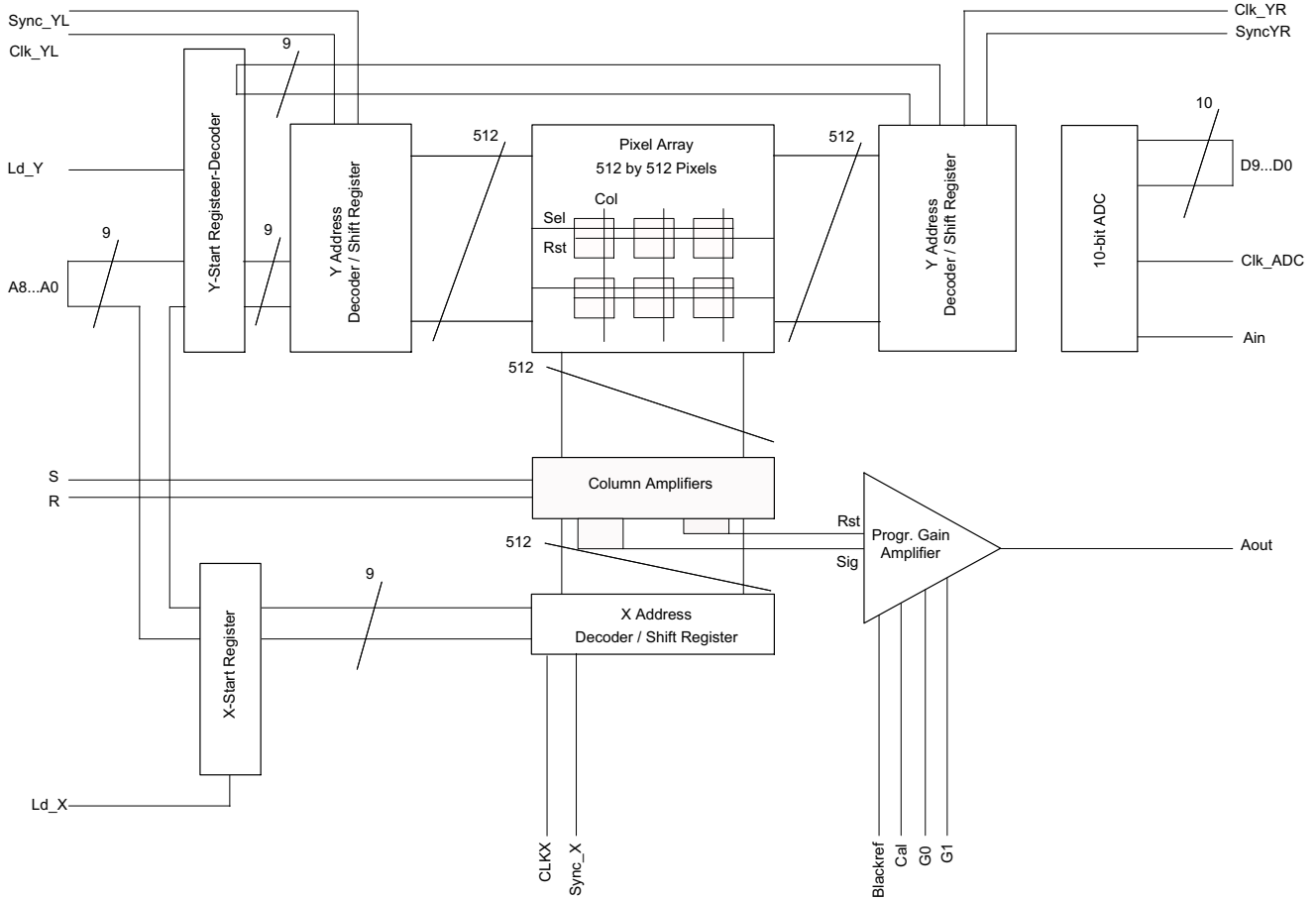

Figure 7. STAR250 Schematic

The base line of the STAR250 sensor design consists of an imager with a 512 by 512 array of active pixels at 25 μm pitch. The detector contains on-chip correction for FPN in the column amplifiers, a programmable gain output amplifier, and a 10-bit ADC. Through additional preset registers, the start position of a window can be programmed to enable fast read out of only part of the detector array.

Pixel Structure

The image sensor consists of several building blocks as outlined in Figure 7. The central element is a 512 by 512 pixel array with square pixels at 25 μm pitch. Unlike classical designs, the pixels of this sensor contain four photodiodes. This configuration enhances the MTF and reduces the PRNU. Figure 8 shows an electrical diagram of the pixel structure. The four photodiodes are connected in parallel to the reset transistor (T1). Transistor T2 converts the charge, collected on the photo diode node, to a voltage

signal that is connected to the column bus by T3. The reset and read entrance of the pixel are connected to one of the Y shift registers.

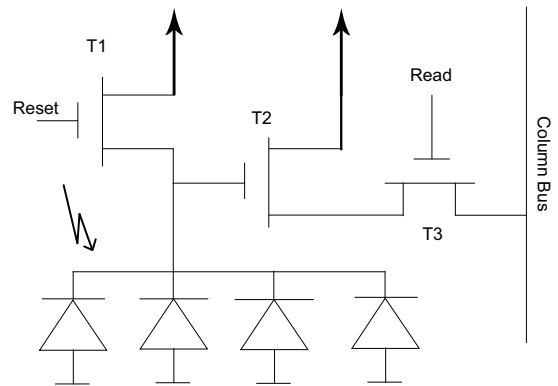

Figure 8. STAR250 Pixel Structure

Shift Registers

The shift registers are located next to the pixel array and contain equal number of outputs and pixel array rows. They are designed as “1-hot” registers, (YL and YR shift register) each allowing selection of one row of pixels at a time. A clock pulse moves the pointer one position down the register resulting in the selection of every individual row for either reset or readout. The spatial offset between the two selected rows determines the integration time. A synchronization pulse to the shift registers loads the value from a preset register into the shift register forcing the pointer to a predetermined position. Windowing in the vertical (Y) direction is achieved by presetting the registers to a row that is not the first row and by clocking out only the required number of rows.

Column Amplifiers

All outputs from the pixels in a column are connected in parallel to a column amplifier. This amplifier samples the output voltage and the reset level of the pixel whose row is selected at that moment and presents these voltage levels to the output amplifier. As a result, the pixels are always reset immediately after readout as part of the sample procedure and the maximum integration time of a pixel is the time between two read cycles.

Electronic Shutter

In a linescan integrating imager with electronic shutter, there are two continuous processes of image gathering.

The first process resets lines in a progressive scan. At line reset, all the pixels in a line are drained from any photo charges collected since their last reset or readout. After reset, a new exposure cycle starts for that particular line.

The second process is the actual readout, which also happens in an equally fast linewise progressive scan.

During readout, the photo charges collected since the previous reset are converted into an output voltage. This is then passed on pixel by pixel to the imager’s pixel serial output and ADC. Readout is destructive, meaning the accumulation of charges from successive exposure phases is not possible in the present architecture.

The STAR250 has two Y shift registers; YL and YR. One is used to read out a line (YL) and the other is used to reset a line (YR). The integration time is equal to the time between the last reset and readout of that line, see Figure 9. The integration time is calculated as follows:

Integration time = (Nr. Lines * (RBT + pixel period * Nr. Pixels)) with:

- Nr. Lines: Number of lines between readout and reset (Y).
- Nr. Pixels: Number of pixels read out each line (X).
- RBT: Row Blanking Time = 3.2 μs (typical).
- Pixel period: 1/8 MHz = 125 ns (typical).

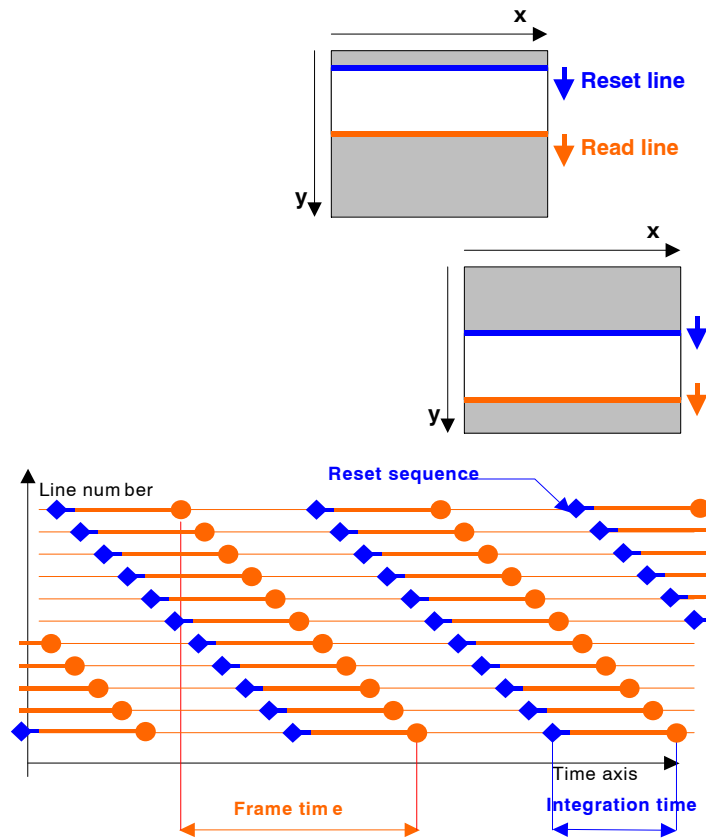

Figure 9. Electronic Shutter

Programmable Gain Amplifier

The signal from the column amplifiers is fed to an output amplifier with four presettable gains (adjustable with pins G0 and G1). The offset correction of this amplifier is done through a black reference procedure. The signal from the output amplifier is externally available on the analog output terminator of the device.

Analog-to-Digital Converter

The on-chip 10-bit ADC is electrically separated from the other circuits of the device. The ADC conversion range is set by the voltages on VLOW_ADC (pin 47) and VHIGH_ADC (pin 70). Make voltages on these pins equal to about 2 V on VLOW_ADC and 4 V on VHIGH_ADC. The voltages are set by connecting VLOW with 1.2 kΩ to GND and VHIGH_ADC with 560 Ω to V_{DD}. This way, a resistor ladder is created as shown in Figure 10.

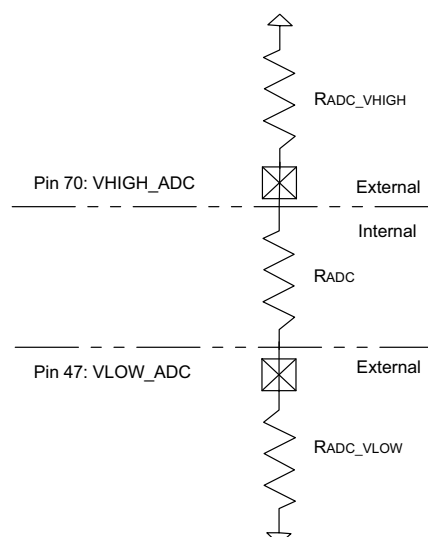

Figure 10. ADC Resistor Ladder

The internal ADC resistance varies according to temperature. The resistance value increases approximately 4.4 Ω/°C with increasing temperature. If the ADC range is set externally with resistors, the conversion range may vary with temperature. This effect is cancelled out by not making use of resistors but directly applying voltages on VLOW_ADC and VHIGH_ADC.

TIMING AND READOUT OF IMAGE SENSOR

Image Readout Procedure

A preamble or initialization phase is irrelevant. The sensor is read out continuously. The first frame is generally saturated and useless because there is no preceding reset of each pixel.

Image Readout

In an infinite uninterrupted loop, follow these steps for every line:

1. Synchronize the read (YL) and/or reset (YR) registers:
 - ◆ SYNC_YL - to reinitiate the readout sequence to row position Y1
 - ◆ SYNC_YR - to reinitiate the reset pointer to row position Y1

For all other lines do not pulse one of these SYNC_Y signals.

2. Operate the double sampling column amplifiers with two RESETs. Apply one to reset the line that is currently selected to produce the reset reference level for the double sampling column amplifiers. Apply the other reset to another line depending on the required integration time reduction.
3. Perform a line readout:
 - ◆ Reset the X read address shift register to the value in its shadow register (X1).
 - ◆ Perform a pixel readout operation, operating the track/hold and the ADC.

- ◆ Shift the X read address shift register one position further.
- ◆ Shift the Y read and reset address shift registers one position further. If either of Y read or reset address shift register comes to the end of the pixel array (or the ROI), wrap it around to the start position by pulsing SYNC_YL.

Readout Timing

The actual line readout process starts with addressing the line to read. This is done either by initializing the YL pointer with a new value or by shifting it one position beyond its previous value. (Addressing the line has reset, YR is done in an analogous fashion). During the “blanking time”, after the new line is addressed on the sensor, the built-in column-parallel double sampling amplifiers are operated. This renders offset-corrected values of the line under readout.

After the blanking time, the pixels of the row addressed by YL are read by multiplexing all the pixels one by one to the serial output chain. The pixel is selected by the X pointer and that pointer is either initialized with a new value or an increment of the previous position.

The time between row resets and their corresponding row readouts is the effective exposure time (or integration time). This time is proportional to the number of lines (DelayLines) between the line currently under reset and the line currently under readout: DelayLines = (YR - YL+1).

NOIS1SM0250A

This time is also equal to the delay between the SYNC_YR pulse and the subsequent SYNC_YR.

The effective integration time tint is calculated as delaylines x line time. The line time is a function of four

terms: the time to output the desired number of pixels in the line (Wframe) and the overhead (“blanking”) time needed to select a new line and perform the double sampling and reset operations.

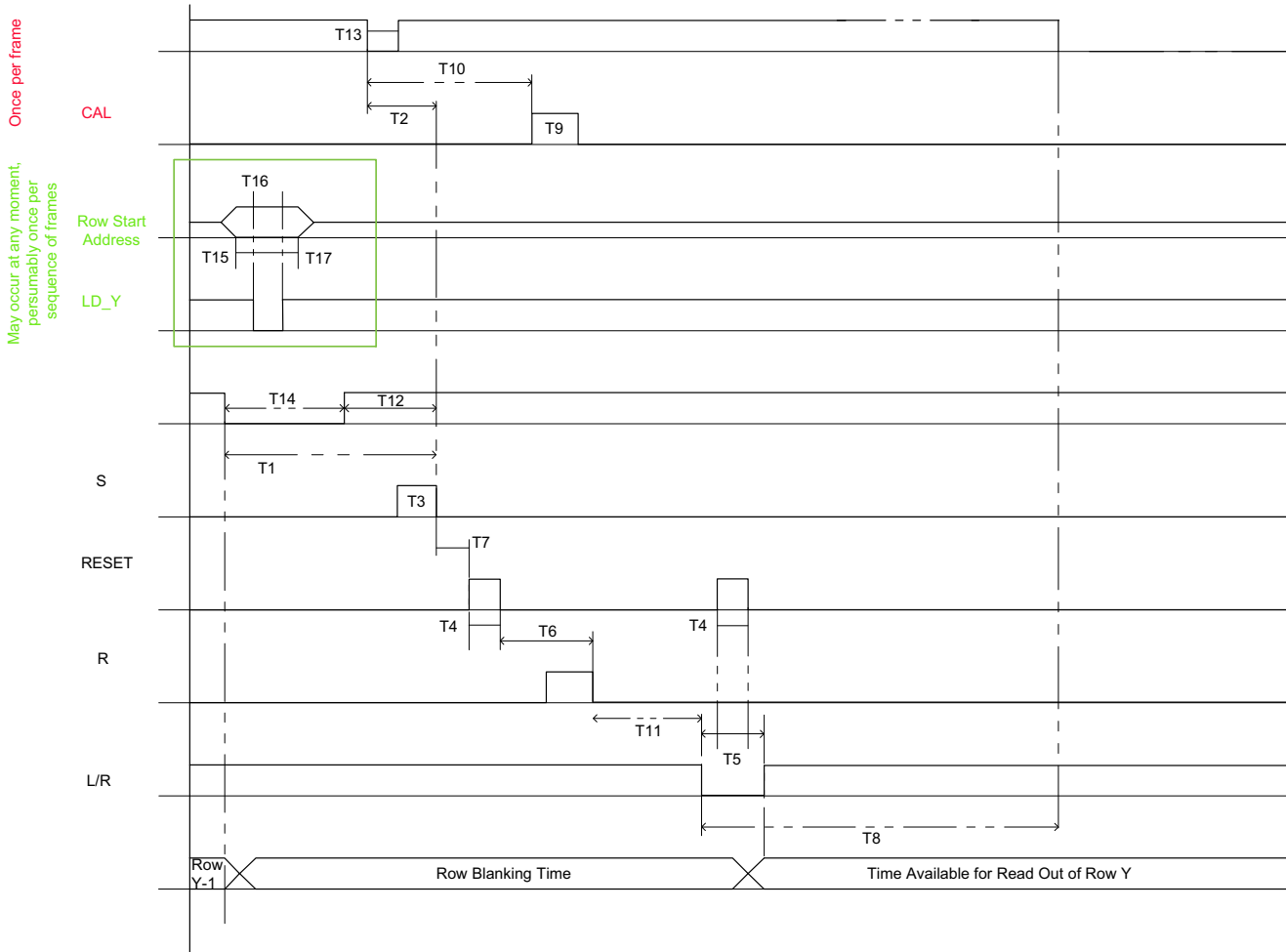

Figure 11. Basic Readout Timing

SYNC_YR is not identical to SYNC_YL. SYNC_YR is used in electronic shutter operation. The CLK_YR is driven identical to CLK_YL, but the SYNC_YR pulse leads the SYNC_YL pulse by a certain number of rows. This lead time is the effective integration (electronic shutter ~) time. Relative to the row timing, both SYNC pulses are given at the same time position, once for each frame, but during different rows.

SYNC_YL is pulsed when the first row is read out and SYNC_YR is pulsed for the electronic shutter to start for this

first row. CAL is pulsed on the first row too, 2 μs later than SYNC_YL.

The minimal idle time is 1.4 μs (before starting reading pixels). However, do not read out pixels during the complete row initialization process (in between the rising edge on S and the falling edge on L/R). In this case, the total idle time is minimal. This timing assumes that the Y start register was loaded in advance, which can occur at any time but before the pulse on SYNC_YL or SYNC_YR.

NOIS1SM0250A

Table 6. READOUT TIMING SPECIFICATIONS

| Symbol | Min | Typ | Description |
|--------|-------------|-------------|---|
| T1 | 1.8 μ s | – | Delay between selection of new row by falling edge on CLK_YL and falling edge on S. Minimal value. Normally, CLK_YR is low already at the end of the previous sequence. |
| T2 | 1.8 μ s | – | Delay between selection of new a row by SYNC_YL and falling edge on S. |
| T3 | 0.4 μ s | – | Duration of S and R pulse. |
| T4 | 0.1 μ s | – | Duration of RESET pulse. |
| T5 | T4 + 40 ns | 0.3 μ s | L/R pulse must overlap second RESET pulse at both sides. |
| T6 | 0.8 μ s | – | Delay between falling edge on RESET and falling edge on R. |
| T7 | 20 ns | 0.1 μ s | Delay between falling edge on S and rising edge on RESET. |
| T8 | 0 | 1 μ s | Delay between falling edge on L/R and falling edge on CLK_Y. |
| T9 | 100 ns | 1 μ s | Duration of cal pulse. The CAL pulse is given once each frame. |
| T10 | 0 | 2 μ s | Delay between falling edge of SYNC_YL and rising edge of CAL pulse. |
| T11 | 40 ns | 0.1 μ s | Delay between falling edge on R and rising edge on L/R. |
| T12 | 0.1 μ s | 1 μ s | Delay between rising edge of CLK_Y and falling edge on S. |
| T13 | – | 0.5 μ s | Pulse width SYNC_YL/YR. |
| T14 | – | 0.5 μ s | Pulse width CLK_YL/YR. |
| T15 | 10 ns | – | Address setup time. |
| T16 | 20 ns | – | Load X/Y start register value. |
| T17 | 10 ns | – | Address stable after load. |
| T18 | 10 ns | – | |
| T19 | 20 ns | – | SYNC_X pulse width. SYNC_X while CLK_X is high. |
| T20 | 10 ns | – | |
| T21 | – | 40 ns | Analog output is stable during CLK_X low. |
| T22 | – | 40 ns | CLK_X pulse width: During this clock phase the analog output ramps to the next pixel level. |
| T23 | – | 125 ns | ADC digital output stable after falling edge of CLK_ADC. |

Loading the X and Y Start Positions

The start positions (start addresses) for region of interest (ROI) are preloaded in the X or Y start register. They become effective by the application of the SYNC_X, SYNC_YL and/or SYNC_YR. The start X or Y address must be applied to their common address bus and the corresponding LD_X or LD_Y pin must be pulsed.

On each falling edge of CLK_X, a new pixel of the same row (line) is accessed. The output stage is in hold when CLK_X is low and starts generating a new output after a rising edge on CLK_X.

The following timing constraints apply:

Load the X or Y start addresses in advance, before the X or Y shift registers are preset by a SYNC pulse. However, if necessary, they can be loaded just before the SYNC_X or SYNC_Y pulse as shown in Figure 12.

For example, the X start register can be loaded during the row idle time. The Y start register can be loaded during readout of the last row of the previous frame.

If the X or Y start address does not change for later frames, it does not need to be reloaded in the register.

NOIS1SM0250A

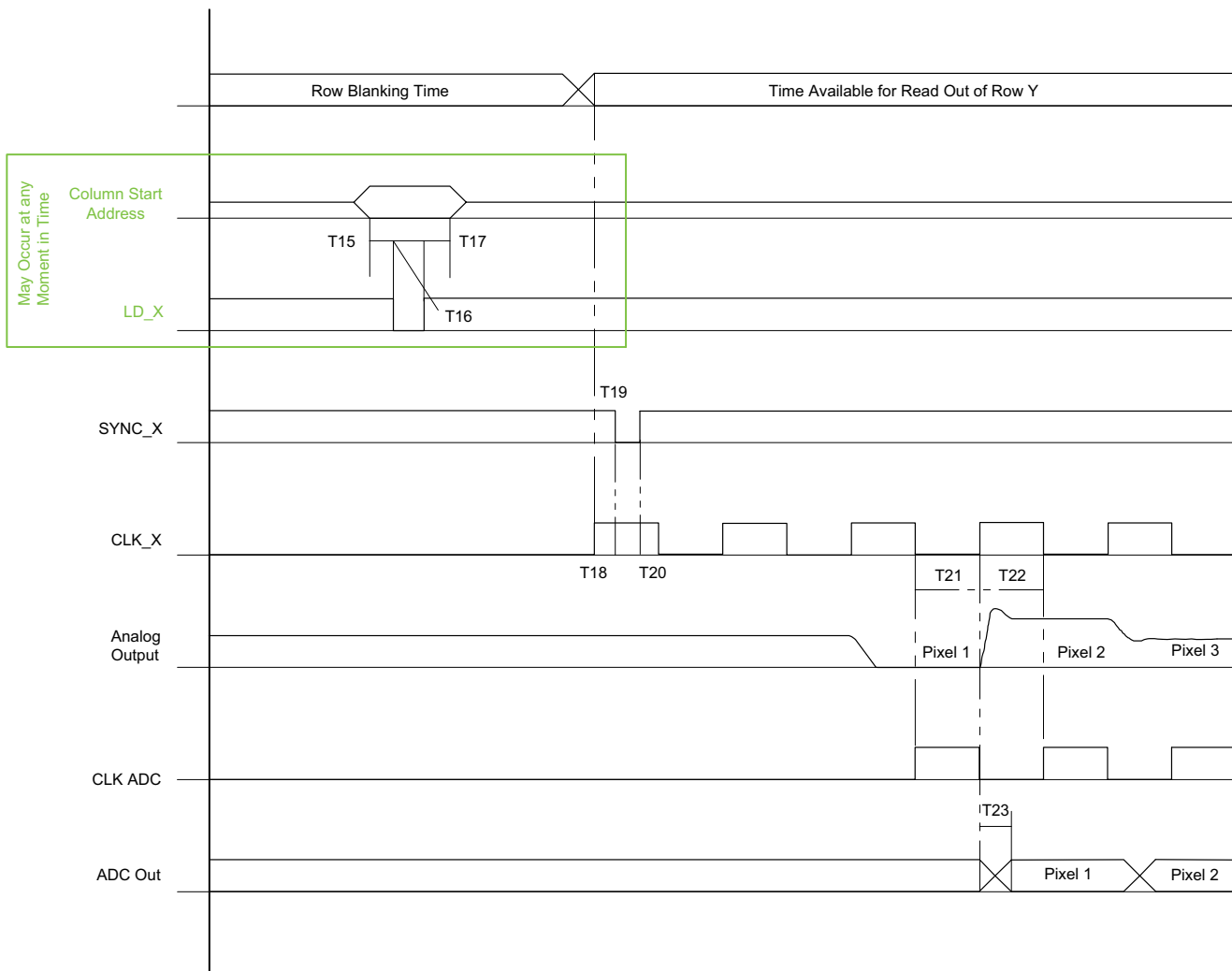

Figure 12. Timing to Load X and Y Registers

Other Signals

Tie SELECT signal to V_{DD} for normal operation. This signal is added for diagnostic reasons and inhibits the pixel array operation when held low.

The CAL signal sets the output amplifier DC offset level. When this signal is active (high) the pixel array is internally disconnected from the output amplifier, its gain is set to unity and its input signal is connected to the BLACK_REF input. Perform this action at least once for each frame.

EOS_X, EOS_YL, and EOS_YR produce a pulse when the respective shift register comes at its end. These outputs are used mainly during testing to verify proper operation of the shift registers.

TESTDIODE and TESTPIXEL_ARRAY are connections to optical test structures that are used for electro optical evaluation. TESTDIODE is a plain photodiode with an area of 14 x 5 pixels. TESTPIXEL_ARRAY is an array (14 x 5) of pixels where the photodiodes are connected in parallel. These structures measure the photocurrent of the diodes directly.

TESTPIXEL_RESET and TESTPIXEL-OUT are connections to a single pixel that are used for testing.

NOIS1SM0250A

PIN LIST

Table 7. POWER SUPPLY CONNECTIONS

| Pin | Pin Name | Pin Description |
|----------|-------------------------------|---|
| 10 | V _{DD_ANA} | Analog power supply 5 V |
| 11 | V _{DD_DIG} | Digital power supply 5 V |
| 31 | V _{DD_AMP} | Power supply of output amplifier 5 V |
| 33 | V _{DD_DIG} | Digital power supply 5 V |
| 34 | V _{DD_ANA} | Analog power supply 5 V |
| 49 | V _{DD_RESR} | Reset power supply 5 V |
| 50 | V _{DD_DIG} | Digital power supply 5 V |
| 53 | V _{DD_ADC_ANA} | ADC analog power supply 5 V |
| 66 | V _{DD_ADC_ANA} | ADC analog power supply 5 V |
| 67 | V _{DD_ADC_DIG} | ADC digital power supply 5 V |
| 69 | V _{DD_ADC_DIG_3.3/5} | ADC 3.3 V power supply for digital output of ADC For interface with 5 V external system: connect to V _{DD_ADC_DIG} For interface with 3.3 V external system: connect to 3.3 V power supply |
| 52 76 | V _{DD_PIX} | Pixel array power supply [default: 5 V, the device is then in 'soft reset'. To avoid the image lag associated with soft reset, reduce this voltage to 3...3.5 V 'hard reset'] |
| 78 | V _{DD_DIG} | Digital power supply 5 V |
| 79 | V _{DD_RESL} | Reset power supply 5 V |

Table 8. GROUND CONNECTIONS

| Pin | Pin Name | Pin Description |
|-----|-------------|----------------------------|
| 9 | GND_ANA | Analog ground |
| 12 | GND_DIG | Digital ground |
| 30 | GND_AMP | Ground of output amplifier |
| 32 | GND_DIG | Digital ground |
| 35 | GND_ANA | Analog ground |
| 51 | GND_DIG | Digital ground |
| 54 | GND_ADC_ANA | ADC analog ground |
| 65 | GND_ADC_ANA | ADC analog ground |
| 68 | GND_ADC_DIG | ADC digital ground |
| 77 | GND_DIG | Digital ground |

Table 9. DIGITAL INPUT SIGNALS

| Pin | Pin Name | Pin Description |
|-----|----------|--|
| 1 | S | Control signal for column amplifier Apply pulse pattern; see Figure 11. |
| 2 | R | Control signal for column amplifier Apply pulse pattern; see Figure 11. |
| 3 | RESET | Resets row indicated by left/right shift register high active (1= reset row) Apply pulse pattern; see Figure 11. |
| 4 | SELECT | Selects row indicated by left/right shift register high active (1=select row) Apply 5 V DC for normal operation |

NOIS1SM0250A

Table 9. DIGITAL INPUT SIGNALS

| Pin | Pin Name | Pin Description |
|-----|-----------|--|
| 5 | L/R | Use left or right shift register for SELECT and RESET 1 = left / 0 = right; see Figure 11. |
| 6 | A0 | Start address for X and Y pointers (LSB) |
| 7 | A1 | Start address for X and Y pointers |
| 8 | A2 | Start address for X and Y pointers |
| 13 | A3 | Start address for X and Y pointers |
| 14 | A4 | Start address for X and Y pointers |
| 15 | A5 | Start address for X and Y pointers |
| 16 | A6 | Start address for X and Y pointers |
| 17 | A7 | Start address for X and Y pointers |
| 18 | A8 | Start address for X and Y pointers (MSB) |
| 19 | LD_Y | Latch address (A0...A8) to Y start register (0 = track, 1 = hold) |
| 20 | LD_X | Latch address (A0...A8) to X start register (0 = track, 1 = hold) |
| 21 | CLK_YL | Clock YL shift register (shifts on falling edge) |
| 22 | SYNC_YL | Sets YL shift register to location preloaded in Y start register Low active (0=sync) Apply SYNC_YL when CLK_YL is high |
| 24 | CLK_X | Clock X shift register (output valid and s when CLK_X is low) |
| 25 | SYNC_X | Sets X shift register to location preloaded in X start register Low active (0=sync) Apply SYNC_X when CLK_X is high After SYNC_X, apply falling edge on CLK_X, and rising edge on CLK_X |
| 27 | CLK_YR | Clock YR shift register (shifts on falling edge) |
| 28 | SYNC_YR | Sets YR shift register to location preloaded in Y start register Low active (0=sync) Apply SYNC_YR when CLK_YR is high |
| 36 | CAL | Initialize output amplifier Output amplifier will output BLACKREF in unity gain mode when CAL is high (1) Apply pulse pattern (one pulse per frame); see Figure 11. |
| 37 | G0 | Select output amplifier gain value: G0 = LSB; G1 = MSB 00 = unity gain; 01 = x2; 10 = x4; 11 = x8 |
| 38 | G1 | idem |
| 71 | CLK_ADC | ADC clock ADC converts on falling edge |
| 75 | BITINVERT | 1 = invert output bits 0 = no inversion of output bits |
| 80 | TRI_ADC | Tristate control of digital ADC outputs 1 = tristate; 0 = output |

NOIS1SM0250A

Table 10. DIGITAL OUTPUT SIGNALS

| Pin | Pin Name | Pin Description |
|-----|----------|---|
| 23 | EOS_YL | End-of-scan of YL shift register Low first clock period after last row (low active) |
| 26 | EOS_X | End-of-scan of X shift register Low first clock period after last active column (low active) |
| 29 | EOS_YR | End-of-scan of YR shift register Low first clock period after last row (low active) |
| 55 | D0 | ADC output bit (LSB) |
| 56 | D1 | ADC output bit |
| 57 | D2 | ADC output bit |
| 58 | D3 | ADC output bit |
| 59 | D4 | ADC output bit |
| 60 | D5 | ADC output bit |
| 61 | D6 | ADC output bit |
| 62 | D7 | ADC output bit |
| 63 | D8 | ADC output bit |
| 64 | D9 | ADC output bit (MSB) |

Table 11. ANALOG INPUT SIGNALS

| Pin | Pin Name | Pin Description |
|----------|-----------------------------------|---|
| 39 | NBIASARR | Connect with 470 k to V_{DD} and decouple to ground with a 100 nF capacitor. |
| 40 | PBIAS | Connect with 39 k to ground and decouple to V_{DD} with a 100 nF capacitor for 8 MHz pixel rate. (Lower resistor values yield higher maximal pixel rates at the cost of extra power dissipation). |
| 41 | NBIAS_AMP | Output amplifier speed/power control. Connect with 51 k Ω to V_{DD} and decouple with 100 nF to GND for 8 MHz output rate (Lower resistor values yield higher maximal pixel rates at the cost of extra power dissipation). |
| 42 | BLACKREF | Control voltage for output signal offset level. Buffered on-chip, the reference level can be generated by a 100 k Ω resistive divider. Connect to ± 2 V DC for use with on-chip ADC. |
| 44 | IN_ADC | Input, connect to sensor output. Input range is between 2 and 4 V (V_{LOW_ADC} and V_{HIGH_ADC}). |
| 45 | NBIASANA2 | Connect with 100 k to V_{DD} and decouple to GND. |
| 46 | NBIASANA | Connect with 100 k to V_{DD} and decouple to GND. |
| 47 70 | V_{LOW_ADC} V_{HIGH_ADC} | Low reference and high reference voltages of ADC should be about 2 V and 4 V. The required voltage settings on V_{LOW_ADC} and V_{HIGH_ADC} can be approximated by tying V_{LOW_ADC} with 1.2 k Ω to GND and V_{HIGH_ADC} with 560 Ω to V_{DD} . |
| 48 | G_AB | Antiblooming drain control voltage: Default: connect to ground. The antiblooming is operational but not maximal. Apply 1 V DC for improved antiblooming. |
| 72 | PBIASDIG2 | Connect with 100 K to GND and decouple to V_{DD} . |
| 73 | PBIASENCLOAD | Connect with 100 K to GND and decouple to V_{DD} . |
| 74 | PBIASDIG1 | Connect with 47 K to GND and decouple to V_{DD} . |

Table 12. ANALOG OUTPUT SIGNALS

| Pin | Pin Name | Pin Description |
|-----|----------|--|
| 43 | OUT | Analog output signal are connected to the analog input of the ADC. |

NOIS1SM0250A

Table 13. TEST STRUCTURES

| Pin | Pin Name | Pin Description |
|-----|------------------|--|
| 81 | TESTDIODE | Plain photo diode, size: 14 x 25 pixels. Must be left open for normal operation. |
| 82 | TESTPIX ARRAY | Array of test pixels, connected in parallel (14 x 25 pixels). Must be left open for normal operation. |
| 83 | TESTPIXEL_RESET | Reset input of single test pixel. Must be tied to GND for normal operation. |
| 84 | TESTPIXEL_OUT | Output of single test pixel. Must be left open for normal operation. |

Glass Lid Specifications

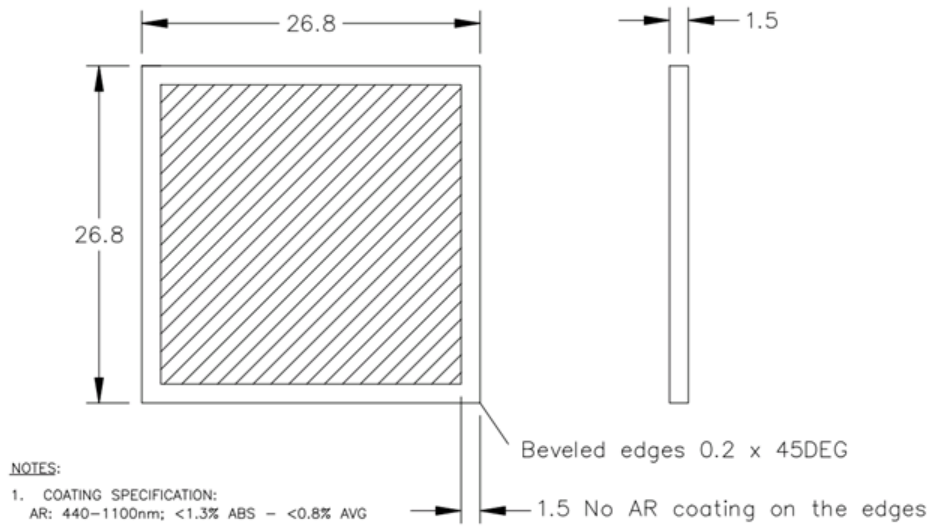
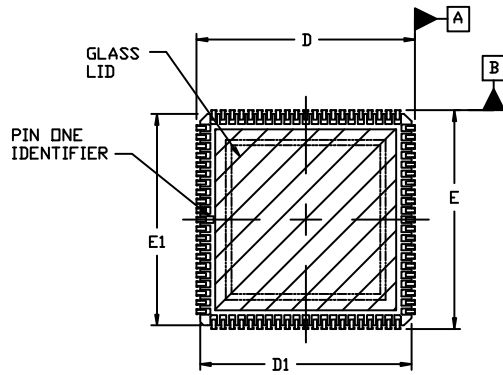

Figure 13. Geometrical Characteristics (in mm)

NOIS1SM0250A

PACKAGE DIMENSIONS

JLDCC84
CASE 114AK
ISSUE A



TOP VIEW

NOTES:

1. DIMENSIONING AND TOLERANCING PER ASME Y14.5M, 1994.
2. CONTROLLING DIMENSION: MILLIMETERS
3. DATUMS A, B, AND D ARE DETERMINED AT DATUM C. POSITION OF THE LEADS IS DETERMINED AT DATUM C.
4. COPLANARITY APPLIES TO THE LOWEST PART OF THE LEAD.

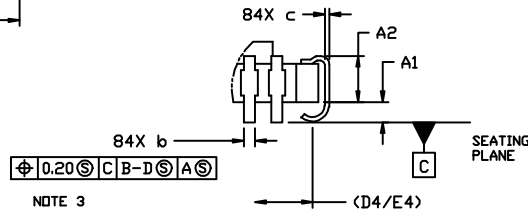

DETAIL A

| DIM | MILLIMETERS | |
|-----|-------------|-------|
| | MIN. | MAX. |
| A | 3.77 | 4.57 |
| A1 | 0.51 | --- |
| A2 | 2.16 | REF |
| b | 0.46 | 0.56 |
| c | --- | 0.20 |
| D | 30.08 | 30.38 |
| D1 | 28.96 | 29.46 |
| D4 | 28.70 | BSC |
| E | 30.08 | 30.38 |
| E1 | 28.96 | 29.46 |
| E4 | 28.70 | BSC |
| e | 1.27 | BSC |
| h | 0.90 | 1.15 |

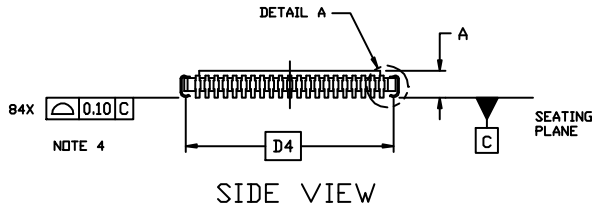

SIDE VIEW

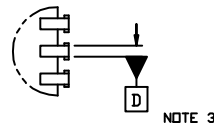

DETAIL B

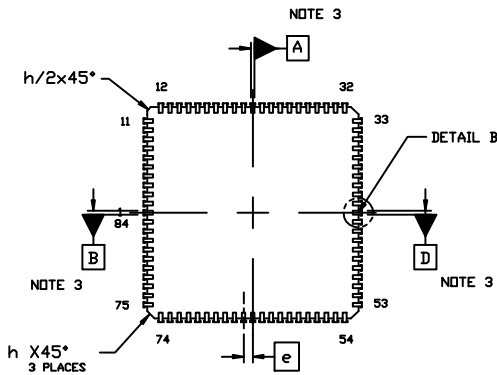

BOTTOM VIEW

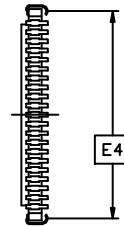

END VIEW

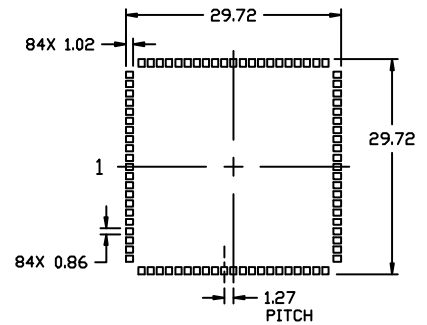

RECOMMENDED MOUNTING FOOTPRINT

Table 14. PACKAGE SPECIFICATIONS

| Type | JLCC-84 |
|-------------------------------|-------------------------|
| Material | Black Alumina BA-914 |
| Thermal expansion coefficient | $7.6 \times 10^{-6} /K$ |

Table 15. MECHANICAL SPECIFICATIONS

| Characteristics | Limits | | | Units |
|-------------------------|--------|-----|-------|-------|
| | Min | Typ | Max | |
| Package tolerance | - | - | 0.15 | mm |
| Die position, X offset | -0.05 | 0 | 0.05 | mm |
| Die position, Y offset | -0.018 | - | 0.118 | mm |
| Die position, planarity | -0.05 | 0 | 0.05 | mm |
| Die position, Y tilt | -0.05 | 0 | 0.05 | mm |

NOTE: Min and Max limits are not measured on every unit, but guaranteed by assembly process.

Die Alignment

The die is aligned manually in the package to a tolerance of $\pm 50 \mu\text{m}$ and the alignment is verified after hardening the die adhesive. All dimensions in Figure 14 are in mm.

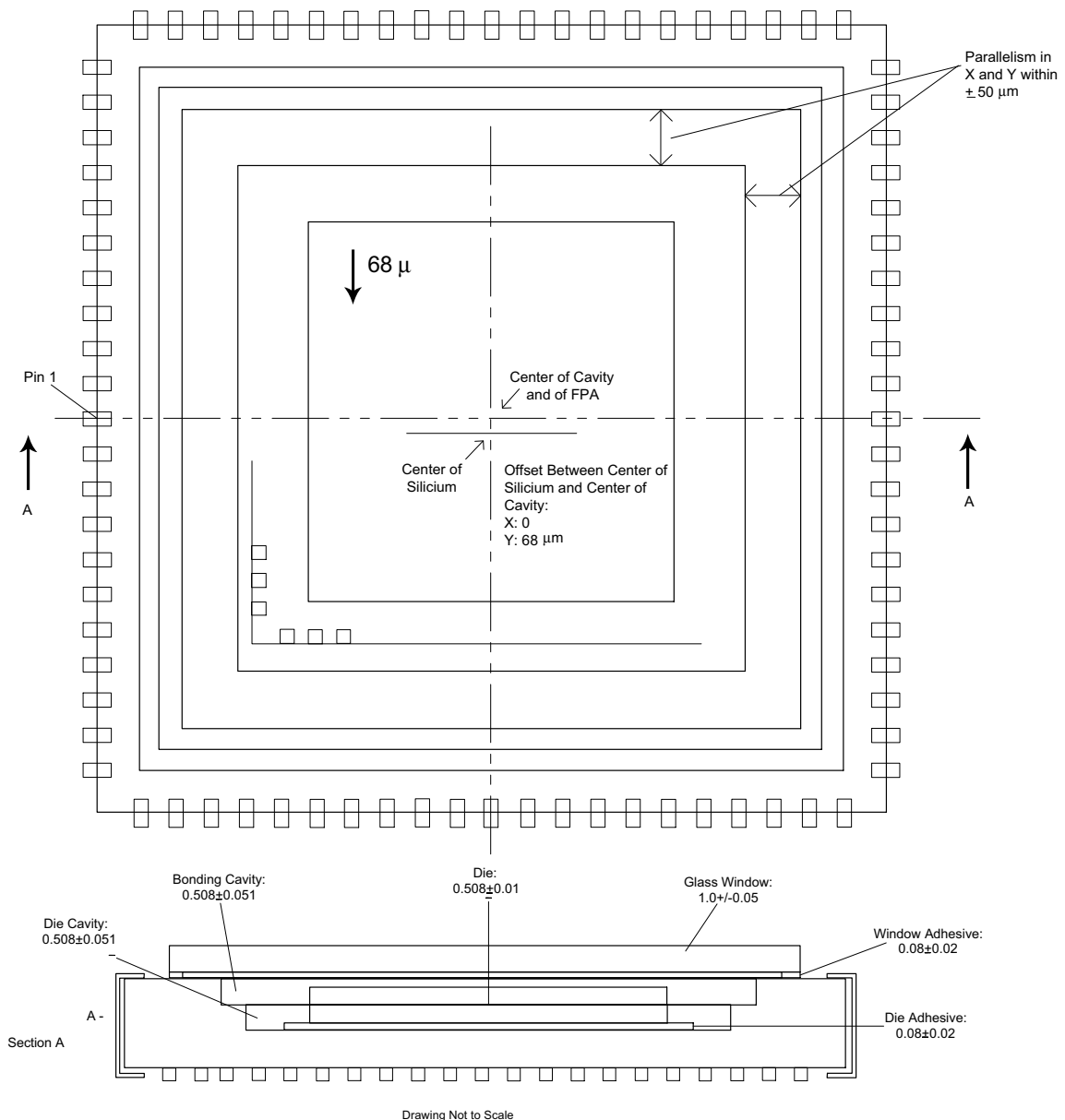

Figure 14. Die Alignment

ADDITIONAL REFERENCES AND RESOURCES

Application Notes and other resources can be found linked to the product web page at www.onsemi.com. Additional information on this device may also be available in the [Image Sensor Portal](#), accessible within the MyON section of www.onsemi.com. A signed NDA is required to access the Image Sensor Portal – please see your ON Semiconductor sales representative for more information.

For information on ESD and cover glass care and cleanliness, please download the Application Note *Image Sensor Handling and Best Practices* (AN52561/D) from www.onsemi.com.

For quality and reliability information, please download the *Quality & Reliability Handbook* (HBD851/D) from www.onsemi.com.

For information on Standard terms and Conditions of Sale, please download [Terms and Conditions](#) document from www.onsemi.com.

For information on Return Material Authorization procedures, please refer to the [RMA Policy Procedure](#) document from www.onsemi.com.

The Product Acceptance Criteria document, which lists criteria to which this device is tested prior to shipment, is available upon request.

NOIS1SM0250A

ACRONYMS

| Acronym | Definition |
|---------|---|
| ADC | analog to digital convertor |
| CIS | CMOS image sensor |
| CMOS | complementary metal oxide semiconductor |
| CY | Cypress |
| DC | dark current |
| DNL | differential nonlinearity |
| DS | double sampling |
| DSNU | dark signal nonuniformity |
| ESD | electrostatic discharge |
| FF | fill factor |
| FPN | fixed pattern noise |
| FPS | frames per second |
| FS | frame start |
| fs | full scale |
| I/O | input/output |
| IMG | image |
| INL | integral nonlinearity |
| IP | intellectual property |
| LDO | low drop-out |
| LSB | least significant bit |
| LVDS | low voltage differential signaling |
| MBS | mixed boundary scan |

| Acronym | Definition |
|---------|------------------------------------|
| MBPS | megabit per second |
| MCIS | multifield point CMOS image sensor |
| MFF | metal fill factor |
| MIM | metal-insulator-metal |
| MP | megapixel |
| Mrad | megaradiation |
| MSB | most significant bit |
| MSPS | megasamples per second |
| MTF | modulation transfer function |
| MUX | multiplexer |
| PCB | printed circuit board |
| PLL | phase-locked loop |
| PLS | parasitic light sensitivity |
| PRBS | pseudo random bit stream |
| PRNU | photo response nonuniformity |
| PSN | photon shot noise |
| PSNL | pixel storage node leakage |
| QC | quantum conversion |
| QE | quantum efficiency |
| QFW | pixel full-well charge |
| RMS | root mean square |
| ROI | region of interest |

NOIS1SM0250A

GLOSSARY

| | |
|-------------------|--|
| conversion gain | A constant that converts the number of electrons collected by a pixel into the voltage swing of the pixel. Conversion gain = q/C where q is the charge of an electron (1.602E 19 Coulomb) and C is the capacitance of the photodiode or sense node. |
| DNL | Differential nonlinearity (for ADCs) |
| DSNU | Dark signal nonuniformity. This parameter characterizes the degree of nonuniformity in dark leakage currents, which can be a major source of fixed pattern noise. |
| fill-factor | A parameter that characterizes the optically active percentage of a pixel. In theory, it is the ratio of the actual QE of a pixel divided by the QE of a photodiode of equal area. In practice, it is never measured. |
| INL | Integral nonlinearity (for ADCs) |
| IR | Infrared. IR light has wavelengths in the approximate range 750 nm to 1 mm. |
| Lux | Photometric unit of luminance (at 550 nm, 1lux = 1 lumen/m ² = 1/683 W/m ²) |
| pixel noise | Variation of pixel signals within a region of interest (ROI). The ROI typically is a rectangular portion of the pixel array and may be limited to a single color plane. |
| photometric units | Units for light measurement that take into account human physiology. |
| PLS | Parasitic light sensitivity. Parasitic discharge of sampled information in pixels that have storage nodes. |
| PRNU | Photo-response nonuniformity. This parameter characterizes the spread in response of pixels, which is a source of FPN under illumination. |
| QE | Quantum efficiency. This parameter characterizes the effectiveness of a pixel in capturing photons and converting them into electrons. It is photon wavelength and pixel color dependent. |
| read noise | Noise associated with all circuitry that measures and converts the voltage on a sense node or photodiode into an output signal. |
| reset | The process by which a pixel photodiode or sense node is cleared of electrons. "Soft" reset occurs when the reset transistor is operated below the threshold. "Hard" reset occurs when the reset transistor is operated above threshold. |
| reset noise | Noise due to variation in the reset level of a pixel. In 3T pixel designs, this noise has a component (in units of volts) proportionality constant depending on how the pixel is reset (such as hard and soft). In 4T pixel designs, reset noise can be removed with CDS. |
| responsivity | The standard measure of photodiode performance (regardless of whether it is in an imager or not). Units are typically A/W and are dependent on the incident light wavelength. Note that responsivity and sensitivity are used interchangeably in image sensor characterization literature so it is best to check the units. |
| ROI | Region of interest. The area within a pixel array chosen to characterize noise, signal, crosstalk, and so on. The ROI can be the entire array or a small subsection; it can be confined to a single color plane. |
| sense node | In 4T pixel designs, a capacitor used to convert charge into voltage. In 3T pixel designs it is the photodiode itself. |
| sensitivity | A measure of pixel performance that characterizes the rise of the photodiode or sense node signal in Volts upon illumination with light. Units are typically V/(W/m ²)/sec and are dependent on the incident light wavelength. Sensitivity measurements are often taken with 550 nm incident light. At this wavelength, 1 683 lux is equal to 1 W/m ² ; the units of sensitivity are quoted in V/lux/sec. Note that responsivity and sensitivity are used interchangeably in image sensor characterization literature so it is best to check the units. |
| spectral response | The photon wavelength dependence of sensitivity or responsivity. |
| SNR | Signal-to-noise ratio. This number characterizes the ratio of the fundamental signal to the noise spectrum up to half the Nyquist frequency. |
| temporal noise | Noise that varies from frame to frame. In a video stream, temporal noise is visible as twinkling pixels. |

ON Semiconductor and  are trademarks of Semiconductor Components Industries, LLC dba ON Semiconductor or its subsidiaries in the United States and/or other countries. ON Semiconductor owns the rights to a number of patents, trademarks, copyrights, trade secrets, and other intellectual property. A listing of ON Semiconductor's product/patent coverage may be accessed at www.onsemi.com/site/pdf/Patent-Marking.pdf. ON Semiconductor reserves the right to make changes without further notice to any products herein. ON Semiconductor makes no warranty, representation or guarantee regarding the suitability of its products for any particular purpose, nor does ON Semiconductor assume any liability arising out of the application or use of any product or circuit, and specifically disclaims any and all liability, including without limitation special, consequential or incidental damages. Buyer is responsible for its products and applications using ON Semiconductor products, including compliance with all laws, regulations and safety requirements or standards, regardless of any support or applications information provided by ON Semiconductor. "Typical" parameters which may be provided in ON Semiconductor data sheets and/or specifications can and do vary in different applications and actual performance may vary over time. All operating parameters, including "Typicals" must be validated for each customer application by customer's technical experts. ON Semiconductor does not convey any license under its patent rights nor the rights of others. ON Semiconductor products are not designed, intended, or authorized for use as a critical component in life support systems or any FDA Class 3 medical devices or medical devices with a same or similar classification in a foreign jurisdiction or any devices intended for implantation in the human body. Should Buyer purchase or use ON Semiconductor products for any such unintended or unauthorized application, Buyer shall indemnify and hold ON Semiconductor and its officers, employees, subsidiaries, affiliates, and distributors harmless against all claims, costs, damages, and expenses, and reasonable attorney fees arising out of, directly or indirectly, any claim of personal injury or death associated with such unintended or unauthorized use, even if such claim alleges that ON Semiconductor was negligent regarding the design or manufacture of the part. ON Semiconductor is an Equal Opportunity/Affirmative Action Employer. This literature is subject to all applicable copyright laws and is not for resale in any manner.

PUBLICATION ORDERING INFORMATION

LITERATURE FULFILLMENT:

Literature Distribution Center for ON Semiconductor
19521 E. 32nd Pkwy, Aurora, Colorado 80011 USA
Phone: 303-675-2175 or 800-344-3860 Toll Free USA/Canada
Fax: 303-675-2176 or 800-344-3867 Toll Free USA/Canada
Email: orderlit@onsemi.com

N. American Technical Support: 800-282-9855 Toll Free
USA/Canada
Europe, Middle East and Africa Technical Support:
Phone: 421 33 790 2910
Japan Customer Focus Center
Phone: 81-3-5817-1050

ON Semiconductor Website: www.onsemi.com
Order Literature: <http://www.onsemi.com/orderlit>
For additional information, please contact your local
Sales Representative