

DMOS Microstepping Driver with Translator and Overcurrent Protection

FEATURES AND BENEFITS

- Drop-in replacement for A4984
- Proprietary Adaptive Percent Fast Decay option
- Low $R_{DS(on)}$ outputs
- Single supply
- Microstepping up to 32 microsteps per full step
- Full torque step modes
- Short-to-ground protection
- Shorted load protection
- Short-to-battery protection
- Fault output
- Low current Sleep mode, $< 10 \mu A$
- No smoke no fire (NSNF) compliance (ET package)
- Thin profile QFN and TSSOP packages
- Thermal shutdown circuitry
- Synchronous rectification for low power dissipation
- Internal UVLO
- Crossover-current protection

APPLICATIONS

- Video Security Cameras
- Printers
- Scanners
- Robotics
- ATM
- POS

DESCRIPTION

The A5984 is a complete microstepping motor driver with built-in translator for easy operation. It is designed to operate bipolar stepper motors from full-step up to 1/32 step modes. Step modes are selectable by MSx logic inputs. It has an output drive capacity of up to 40 V and $\pm 2 A$.

A5984 introduces a proprietary Adaptive Percent Fast Decay (APFD) algorithm to optimize the current waveform over a wide range of stepper speeds and stepper motor characteristics. APFD adjusts on-the-fly the amount of fast decay during a PWM cycle to keep current ripple at a low level over the various operating conditions. This adaptive feature improves performance of the system resulting in reduced audible motor noise, reduced vibration, and increased step accuracy.

The translator is the key to the easy implementation of the A5984. Simply inputting one pulse on the STEP input drives the motor one microstep. There are no phase sequence tables, high frequency control lines, or complex interfaces to program. The A5984 interface is an ideal fit for applications where a complex microprocessor is unavailable or is overburdened.

The ET package meets customer requirements for no smoke no fire (NSNF) designs by adding no-connect pins between critical output, sense, and supply pins. So, in the case of a pin-to-adjacent-pin short, the device does not cause smoke or fire. Additionally, the device does not cause smoke or fire when any pin is shorted to ground or left open.

Continued on the next page...

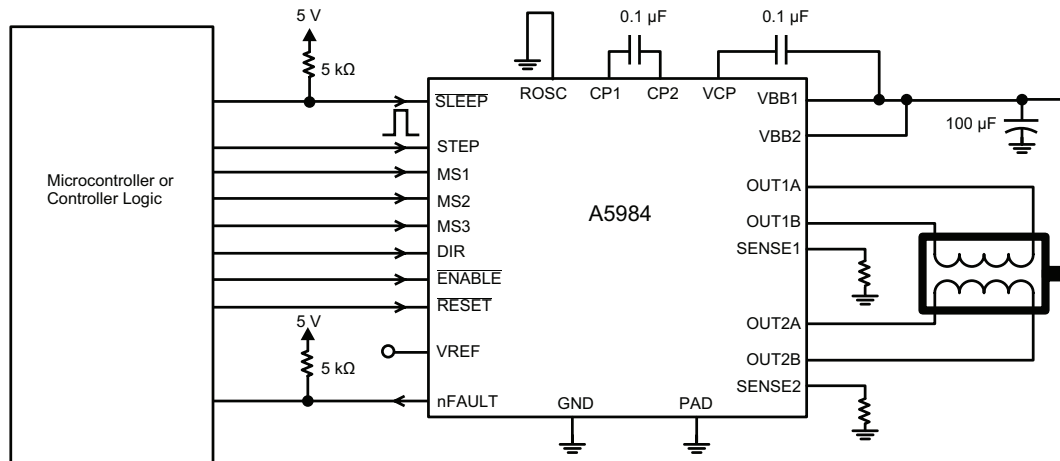

Typical Application Diagram

PACKAGES:

24-contact QFN
with exposed thermal pad
4 mm × 4 mm × 0.75 mm
(ES package)

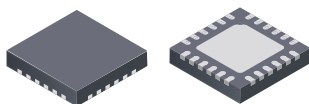

32-contact QFN
with exposed thermal pad
5 mm × 5 mm × 0.90 mm
(ET package)

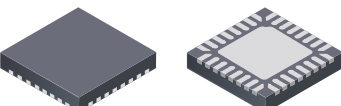

24-pin TSSOP
with exposed thermal pad
(LP Package)

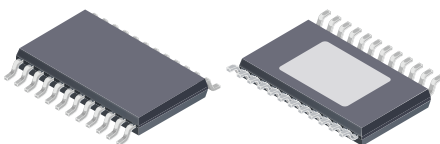

DESCRIPTION (continued)

Internal synchronous rectification control circuitry is provided to improve power dissipation during PWM operation. Internal circuit protection includes: thermal shutdown with hysteresis, undervoltage lockout (UVLO), and crossover-current protection. Special power-on sequencing is not required.

The A5984 is supplied in three surface mount packages: two QFN packages, the 4 mm × 4 mm, 0.75 mm nominal overall height ES package, and the 5 mm × 5 mm × 0.90 mm ET package. The LP package is a 24-pin TSSOP. All three packages have exposed pads for enhanced thermal dissipation, and are lead (Pb) free (suffix -T), with 100% matte-tin-plated leadframes.

SPECIFICATIONS

SELECTION GUIDE

Part Number	Package	Packing
A5984GESTR-T	24-pin QFN with exposed thermal pad	1500 pieces per 7-in. reel
A5984GETTR-T*	32-pin QFN with exposed thermal pad	1500 pieces per 7-in. reel
A5984GLPTR-T	24-pin TSSOP with exposed thermal pad	4000 pieces per 13-in. reel

* Contact marketing for availability.

ABSOLUTE MAXIMUM RATINGS

Characteristic	Symbol	Notes	Rating	Units
Load Supply Voltage	V_{BB}		40	V
Output Current	I_{OUT}		±2	A
Logic Input Voltage	V_{IN}		-0.3 to 6	V
Motor Outputs Voltage			-2.0 to $V_{BB} + 2 V$	V
Sense Voltage	V_{SENSE}		-0.5 to 0.5	V
Reference Voltage	V_{REF}		5.5	V
Operating Ambient Temperature	T_A	Range G	-40 to 105	°C
Maximum Junction	$T_J(max)$		150	°C
Storage Temperature	T_{stg}		-55 to 150	°C

Table of Contents

Specifications	2	Protection Functions	13
Functional Block Diagram	4	Fault Output (nFAULT)	13
Pinout Diagrams and Terminal List Table	5	Thermal or Undervoltage Fault Shutdown	13
Electrical Characteristics	6	Overcurrent Protection	13
Thermal Characteristics	7	Application Information	14
Logic Interface	8	Layout	14
Functional Description	9	Pin Circuit Diagrams	15
Device Operation	9	Phase Current Diagrams	16
Stepping Current Control	9	Full Step (100% Torque)	16
100 Percent Torque Operation	9	Half Step (100% Torque)	16
Microstep Select (MSx)	9	Sixteenth Step	17
Reset Input (RESET)	9	Thirty-Secondth Step	17
Step Input (STEP)	12	Full Step (Modified)	18
Direction Input (DIR)	12	Half Step (Modified)	18
Internal PWM Current Control	12	Eighth Step	19
Blanking	12	Quarter Step	19
ROSC	12	Stepping Phase Tables	20
Charge Pump (CP1 and CP2)	12	Full Torque Modes	20
Enable Input (ENABLE)	12	Common Modes	21
Sleep Mode (SLEEP)	13	Package Outline Drawings	25
Synchronous Rectification	13		

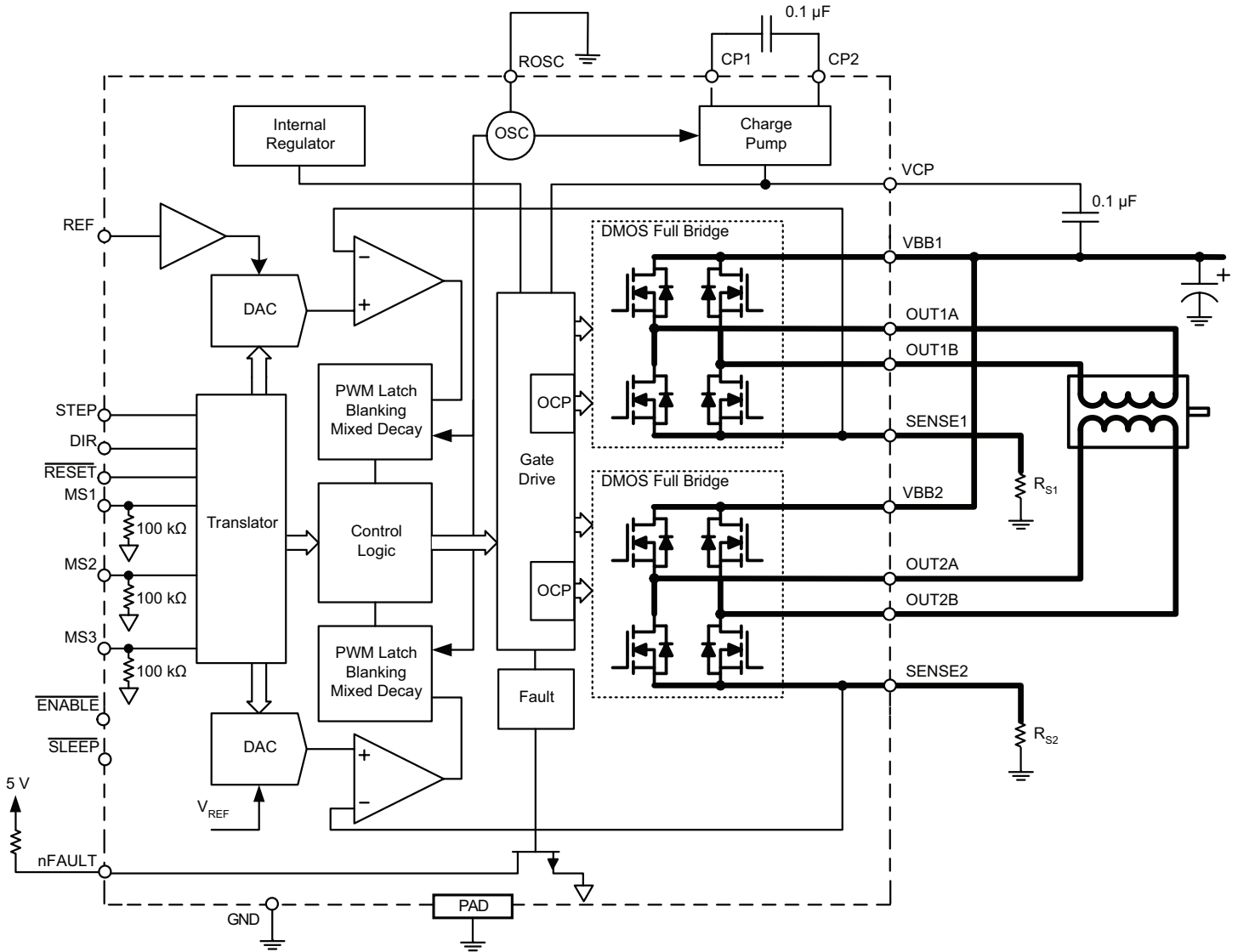

Functional Block Diagram

Pinout Diagrams and Terminal List Table

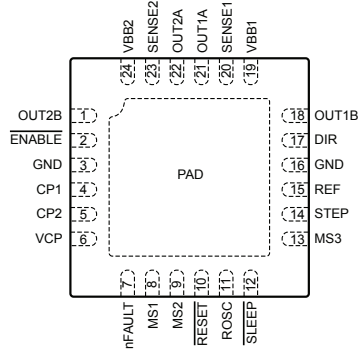

ES Package Pinouts

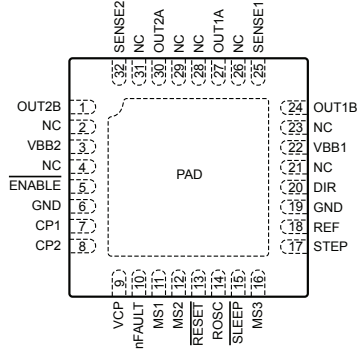

ET Package Pinouts

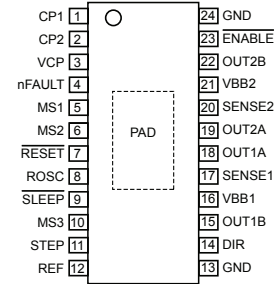

LP Package Pinouts

Terminal List Table

Name	Number			Description
	ES	ET*	LP	
CP1	4	7	1	Charge pump capacitor terminal
CP2	5	8	2	Charge pump capacitor terminal
DIR	17	20	14	Logic input
ENABLE	2	5	23	Logic input
nFAULT	7	10	4	Fault output, active low
GND	3, 16	6, 19	13, 24	Ground
MS1	8	11	5	Logic input
MS2	9	12	6	Logic input
MS3	13	16	10	Logic input
NC	-	2, 4, 21, 23, 26, 28, 29, 31	-	No connection
OUT1A	21	27	18	DMOS Full Bridge 1 Output A
OUT1B	18	24	15	DMOS Full Bridge 1 Output B
OUT2A	22	30	19	DMOS Full Bridge 2 Output A
OUT2B	1	1	22	DMOS Full Bridge 2 Output B
REF	15	18	12	G _m reference voltage input
RESET	10	13	7	Logic input
ROSC	11	14	8	Timing set
SENSE1	20	25	17	Sense resistor terminal for Bridge 1
SENSE2	23	32	20	Sense resistor terminal for Bridge 2
SLEEP	12	15	9	Logic input
STEP	14	17	11	Logic input
VBB1	19	22	16	Load supply
VBB2	24	3	21	Load supply
VCP	6	9	3	Reservoir capacitor terminal
PAD	-	-	-	Exposed pad for enhanced thermal dissipation*

*The GND pins must be tied together externally by connecting to the PAD ground plane under the device.

ELECTRICAL CHARACTERISTICS [1] valid at $T_A = 25^\circ\text{C}$, $V_{BB} = 40\text{ V}$ (unless otherwise noted)

Characteristics	Symbol	Test Conditions	Min.	Typ. [2]	Max.	Units
OUTPUT DRIVERS						
Load Supply Voltage Range	V_{BB}	Operating	8	–	40	V
		During Sleep Mode	0	–	40	V
Output On Resistance	$R_{DS(on)}$	Source + Sink Driver, $I_{OUT} = -2\text{ A}$, $T_A = 25^\circ\text{C}$	–	640	860	m Ω
Body Diode Forward Voltage	V_F	Source Diode, $I_F = -2\text{ A}$	–	–	1.4	V
		Sink Diode, $I_F = 2\text{ A}$	–	–	1.4	V
Output Driver Slew Rate	SR_{OUT}	10% to 90%	50	100	150	ns
Motor Supply Current	I_{BB}	$f_{PWM} < 50\text{ kHz}$	–	7.5	10	mA
		Operating, outputs disabled	–	6.5	8	mA
		Sleep Mode	–	–	10	μA
CONTROL LOGIC						
Logic Input Voltage	$V_{IN(1)}$		2	–	–	V
	$V_{IN(0)}$		–	–	0.8	V
	$V_{IN(SLEEP)}$		–	–	0.4	V
Logic Input Current	$I_{IN(1)}$		–20	<1.0	20	μA
	$I_{IN(0)}$		–20	<1.0	20	μA
Microstep Select Pins Internal Pull-Down Resistance	R_{MSx}	MS1, MS2, or MS3 pin	–	100	–	k Ω
Logic Input Hysteresis	$V_{HYS(IN)}$		200	–	550	mV
Blank Time	t_{BLANK}		0.7	1	1.3	μs
Fixed Off-Time	t_{OFF}	ROSC = 5 V	20	30	40	μs
		ROSC = GND	13	16	19	μs
		$R_{OSC} = 25\text{ k}\Omega$	23	30	37	μs
Reference Input Voltage Range	V_{REF}		0	–	4	V
Reference Input Current	I_{REF}		–3	0	3	μA
Current Trip-Level Error [3]	err_I	$V_{REF} = 2\text{ V}$, $\%I_{TripMAX} = 38.27\%$	–	–	± 15	%
		$V_{REF} = 2\text{ V}$, $\%I_{TripMAX} = 70.71\%$	–	–	± 5	%
		$V_{REF} = 2\text{ V}$, $\%I_{TripMAX} = 100.00\%$	–	–	± 5	%
Crossover Dead Time	t_{DT}		100	475	800	ns
Fault Output Voltage	V_{RST}	nFAULT pin, $I_{OUT} = 1\text{ mA}$	–	–	0.5	V
Fault Output Leakage Current	I_{LK}	nFAULT pin, no fault, pull-up to 5 V	–	–	1	μA
PROTECTION						
Overcurrent Protection Threshold [4]	I_{OCPST}		2.6	–	–	A
VBB UVLO	V_{BBUVLO}	V_{BB} rising	6.3	–	6.85	V
VBB UVLO Hysteresis	V_{BBHYS}		–	300	–	mV
Thermal Shutdown Temperature	T_{TSD}		–	165	–	$^\circ\text{C}$
Thermal Shutdown Hysteresis	T_{TSDHYS}		–	20	–	$^\circ\text{C}$

¹ For input and output current specifications, negative current is defined as coming out of (sourcing) the specified device pin.

² Typical data are for initial design estimations only, and assume optimum manufacturing and application conditions. Performance may vary for individual units, within the specified maximum and minimum limits.

³ $V_{ERR} = [(V_{REF}/8) - V_{SENSE}] / (V_{REF}/8)$.

⁴ Overcurrent protection (OCP) is tested at $T_A = 25^\circ\text{C}$ in a restricted range and guaranteed by characterization.

THERMAL CHARACTERISTICS may require derating at maximum conditions

Characteristic	Symbol	Test Conditions*	Value	Units
Package Thermal Resistance	$R_{\theta JA}$	ES package; estimated, on 4-layer PCB, based on JEDEC standard	37	°C/W
		ET package; estimated, on 4-layer PCB, based on JEDEC standard	32	°C/W
		LP package; on 4-layer PCB, based on JEDEC standard	28	°C/W

*In still air. Additional thermal information available on Allegro website.

Maximum Power Dissipation, $P_D(\max)$

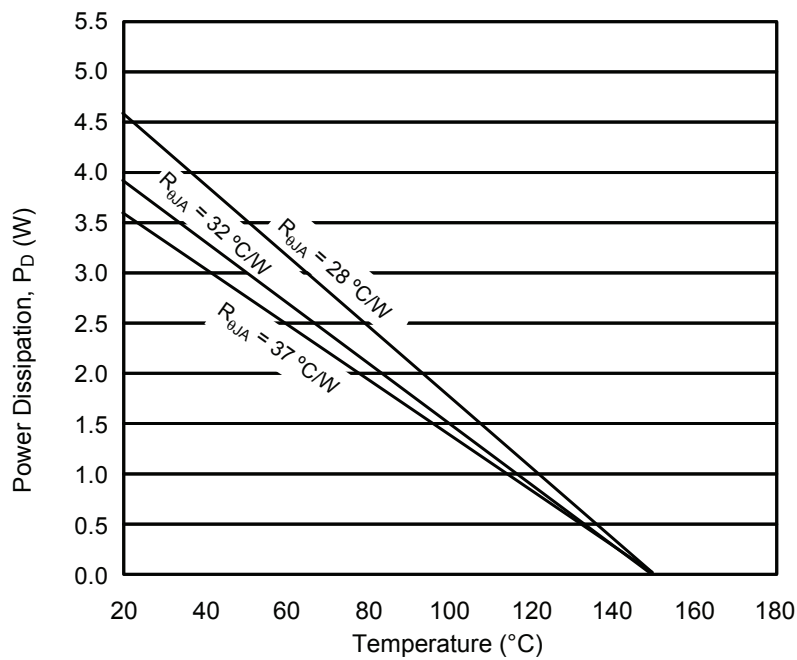

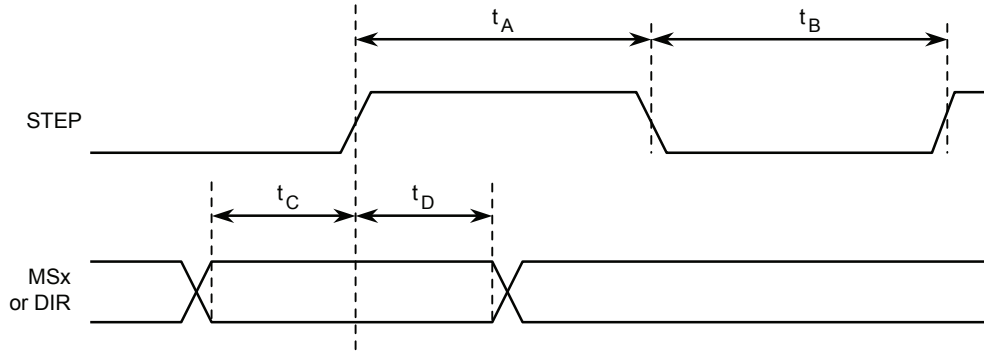

Time Duration	Symbol	Typ.	Unit
STEP minimum, HIGH pulse width	t_A	1	μs
STEP minimum, LOW pulse width	t_B	1	μs
Setup time, input change to STEP	t_C	400	ns
Hold time, input change to STEP	t_D	400	ns

Figure 1: Logic Interface Timing Diagram

Table 1: Microstep Resolution Truth Table

MS3	MS2	MS1	Microstep Resolution
0	0	0	Full step (100% torque)
0	0	1	Half step (100% torque)
0	1	0	Sixteenth step
0	1	1	Thirty-secondth step
1	0	0	Full step (modified)
1	0	1	Half step (modified)
1	1	0	Quarter step
1	1	1	Eighth step

FUNCTIONAL DESCRIPTION

Device Operation

The A5984 is a complete microstepping motor driver with a built-in translator for easy operation with minimal control lines. It is designed to operate bipolar stepper motors in full, half, quarter, eighth, sixteenth, or thirty-secondth step modes. The currents in each of the two output full-bridges and all of the N-channel DMOS FETs are regulated with fixed off-time PWM (pulse width modulated) control circuitry. At each step, the current for each full-bridge is set by the value of its external current-sense resistor (R_{S1} and R_{S2}), a reference voltage (V_{REF}), and the output voltage of its DAC (which in turn is controlled by the output of the translator).

At power-on or reset, the translator sets the DACs and the phase current polarity to the initial Home state (shown in the Phase Current Diagrams section), and the current regulator to Mixed Decay Mode for both phases. When a step command signal occurs on the STEP input, the translator automatically sequences the DACs to the next level and current polarity. (See Table 2 for the current-level sequence.) The microstep resolution is set by the combined effect of the MSx inputs, as shown in Table 1.

Stepping Current Control

The A5984 has two methods of current control. The first method of current control is called Adaptive Percent Fast Decay (APFD). APFD is selected by connecting pin ROSC to GND. Essentially, the IC determines the proper amount of fast decay on both rising and falling currents. By only adding fast decay when needed, the output current more accurately tracks the input command from the D-to-A converter and solves the basic problem of current discontinuity through zero when stepping at slow speeds (see Figure 4). This will result in a performance advantage for slow-speed high-resolution stepping such as with security camera applications. An additional benefit of APFD is reduced current ripple across the various operating conditions and motor characteristics.

The other method of current control utilizes slow decay mode when current is rising and mixed decay mode (31.25%) when current is falling. This method is exactly the same as A4984 series of stepper motor drivers. This method may be desired for drop-in applications to A4984 series. The current waveform and motor performance should be identical to A4984. The mixed decay waveforms for this method are shown in Figure 2. This form of current control is selected by connecting pin ROSC to greater than 3 V or by connecting a resistor from ROSC to GND. The Resistor option is used to adjust the off-time as desired (see ROSC section).

100 Percent Torque Operation

In full- and half-step modes, the device can be programmed so both phases are at $\pm 100\%$ current levels for full step mode, and either $\pm 100\%$ or 0% for half step mode.

Microstep Select (MSx)

The microstep resolution is set by the voltage on logic inputs MSx, as shown in Table 1. Each MSx pin has an internal 100 k Ω pull-down resistance. When changing the step mode the change does not take effect until the next STEP rising edge.

If the step mode is changed without a translator reset, and absolute position must be maintained, it is important to change the step mode at a step position that is common to both step modes in order to avoid missing steps. When the device is powered down, or reset due to TSD or an over current event the translator is set to the home position which is by default common to all step modes.

Reset Input ($\overline{\text{RESET}}$)

The $\overline{\text{RESET}}$ input sets the translator to a predefined Home state (shown in Phase Current Diagrams section), and turns off all of the FET outputs. All STEP inputs are ignored until the $\overline{\text{RESET}}$ input is set to high.

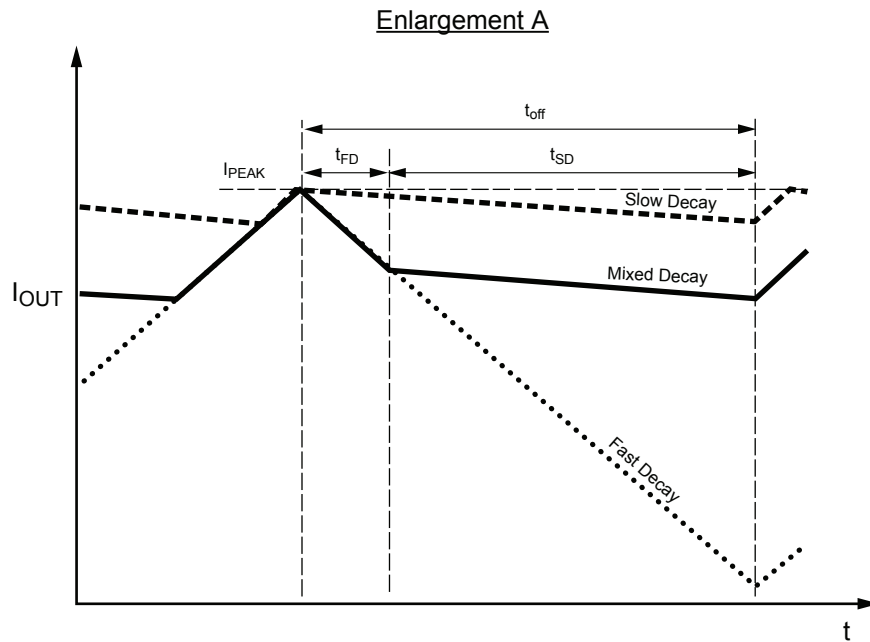
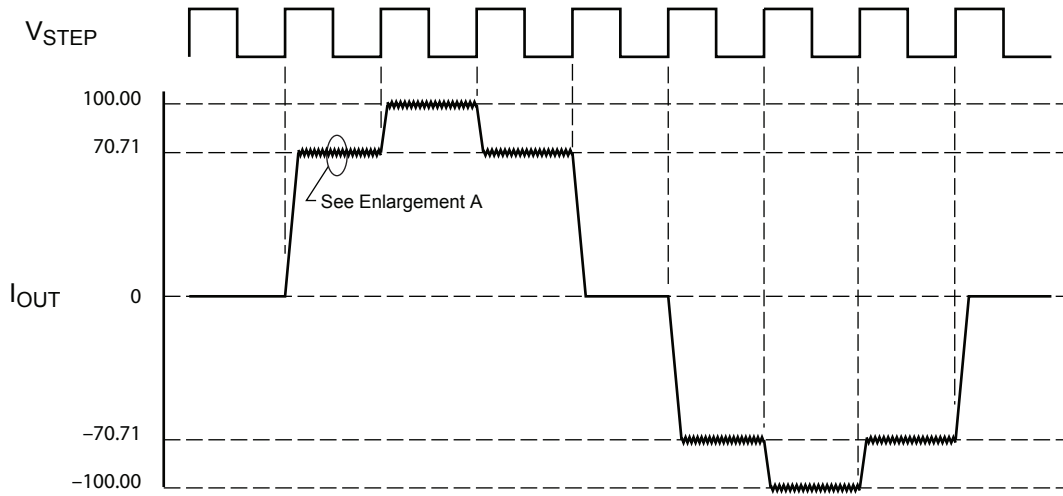

Symbol	Characteristic
t_{off}	Device fixed off-time
I_{PEAK}	Maximum output current
t_{SD}	Slow decay interval
t_{FD}	Fast decay interval
I_{OUT}	Device output current

Figure 2: Current Decay Modes Timing Chart

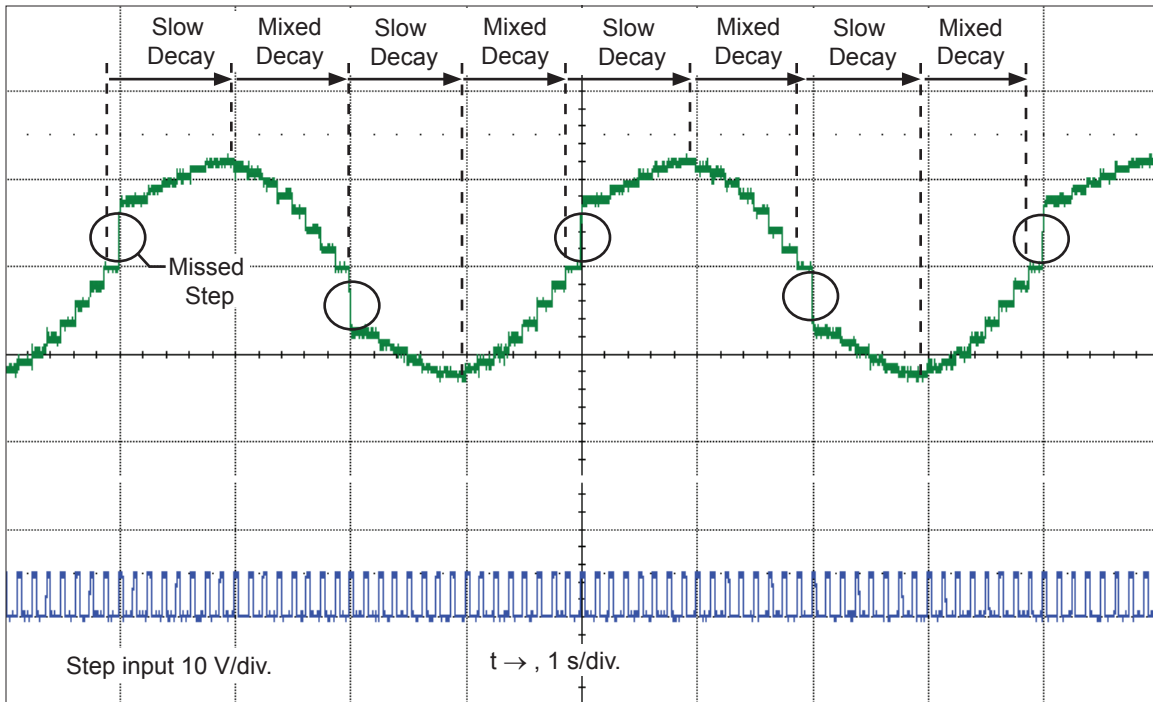

Figure 3: Missed Steps in Low-Speed Microstepping

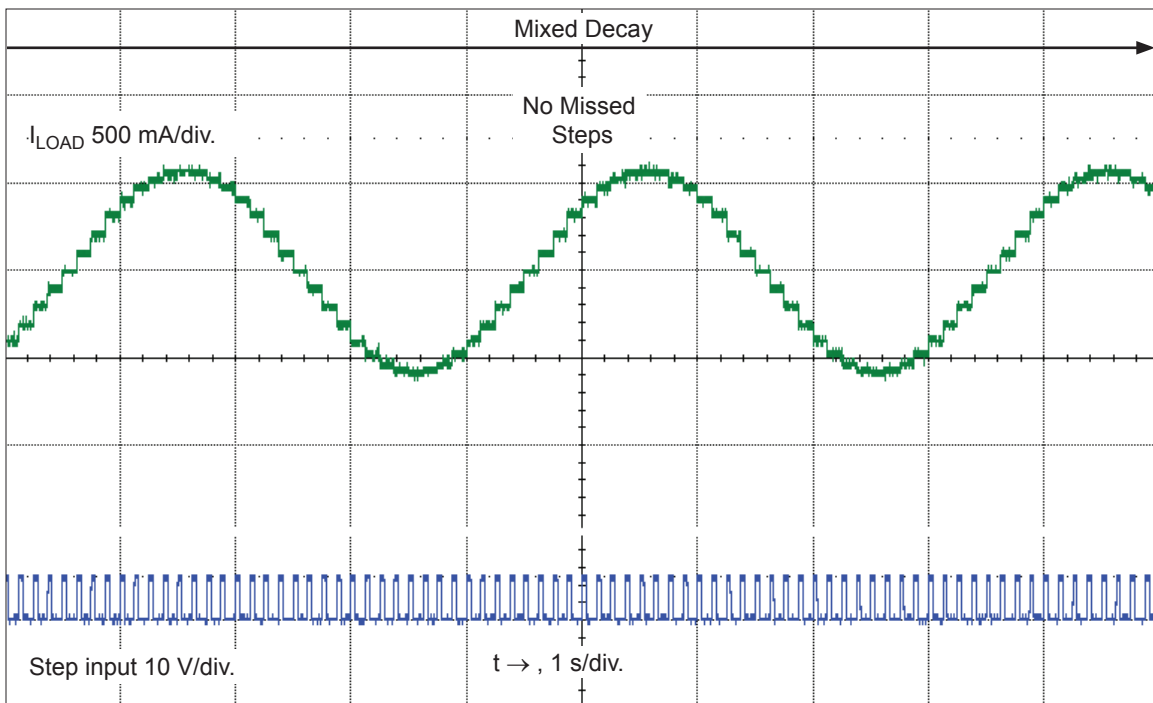

Figure 4: Continuous Stepping Using APFD (ROSC Pin Grounded)

Step Input (STEP)

A low-to-high transition on the STEP input sequences the translator and advances the motor one increment. The translator controls the input to the DACs and the direction of current flow in each winding. The size of the increment is determined by the combined state of the MSx inputs.

Direction Input (DIR)

This determines the direction of rotation of the motor. Setting to logic high and logic low set opposite rotational directions. Changes to this input do not take effect until the next STEP input rising edge. Refer to Phase Current diagrams (Figures 10 to 17). For DIR = LOW, currents change sequentially clockwise around the circle. For DIR = HIGH, counterclockwise.

Internal PWM Current Control

Each full-bridge is controlled by a fixed off-time PWM current control circuit that limits the load current to a desired value, I_{TRIP} . Initially, a diagonal pair of source and sink FET outputs are enabled and current flows through the motor winding and the current sense resistor, R_{Sx} . When the voltage across R_{Sx} equals the DAC output voltage, the current sense comparator resets the PWM latch. The latch then turns off either the source FET (when in Slow decay mode) or the sink and source FETs (when in Mixed decay mode).

The maximum value of current limiting is set by the selection of R_{Sx} and the voltage at the VREF pin. The transconductance function is approximated by the maximum value of current limiting, $I_{TripMAX}$ (A), which is set by

$$I_{TripMAX} = V_{REF} / (8 \times R_S)$$

where R_S is the resistance of the sense resistor (Ω) and V_{REF} is the input voltage on the REF pin (V).

The DAC output reduces the V_{REF} output to the current sense comparator in precise steps, such that

$$I_{trip} = (\%I_{TripMAX} / 100) \times I_{TripMAX}$$

(See table 2 for $\%I_{TripMAX}$ at each step.)

It is critical that the maximum rating (0.5 V) on the SENSE1 and SENSE2 pins is not exceeded.

Blanking

This function blanks the output of the current sense comparators when the outputs are switched by the internal current control circuitry. The comparator outputs are blanked to prevent false overcurrent detection due to reverse recovery currents of the clamp diodes, and switching transients related to the capacitance of the load. The blank time, t_{BLANK} (μ s), is approximately

$$t_{BLANK} \approx 1 \mu s$$

ROSC

The configuration of the ROSC terminal determines both the method of current control as well as the fixed off-time (t_{OFF}).

ROSC	Decay Mode	t_{OFF}
GND	APFD (Adaptive Percent Fast Decay Mode)	16 μ s
Resistor to GND	Slow Decay Rising Current Steps Mixed Decay Falling Current Steps	ROSC/825 (μ s)
Pulled Up to > 3 V Supply	Slow Decay Rising Current Steps Mixed Decay Falling Current Steps	30 μ s

Charge Pump (CP1 and CP2)

The charge pump is used to generate a gate supply greater than that of VBB for driving the source-side FET gates. A 0.1 μ F ceramic capacitor, should be connected between CP1 and CP2. In addition, a 0.1 μ F ceramic capacitor is required between VCP and VBB, to act as a reservoir for operating the high-side FET gates.

Capacitor values should be Class 2 dielectric $\pm 15\%$ maximum, or tolerance R, according to EIA (Electronic Industries Alliance) specifications.

Enable Input (\overline{ENABLE})

This input turns on or off all of the FET outputs. When set to a logic high, the outputs are disabled. When set to a logic low, the internal control enables the outputs as required. The translator inputs STEP, DIR, and MSx, as well as the internal sequencing logic, all remain active, independent of the \overline{ENABLE} input state.

Sleep Mode (\overline{SLEEP})

To minimize power consumption when the motor is not in use, SLEEP disables much of the internal circuitry including the

output FETs, current regulator, and charge pump. A logic low on the $\overline{\text{SLEEP}}$ pin puts the A5984 into Sleep mode. A logic high allows normal operation, as well as start-up (at which time the A5984 drives the motor to the Home microstep position). When emerging from Sleep mode, in order to allow the charge pump to stabilize, provide a delay of 1 ms before issuing a Step command.

Synchronous Rectification

When a PWM-off cycle is triggered by an internal fixed-off time cycle, load current recirculates according to the decay mode selected by the control logic. This synchronous rectification feature turns on the appropriate FETs during current decay, and effectively shorts out the body diodes with the low FET $R_{\text{DS(on)}}$. This reduces power dissipation significantly, and can eliminate the need for external Schottky diodes in many applications. Synchronous rectification turns off when the load current approaches zero (0 A), preventing reversal of the load current.

Protection Functions

FAULT OUTPUT (nFAULT)

An open drain fault output is provided to notify the user if the IC has been disabled due to an OCP event. If an OCP event is triggered the device will be disabled and the outputs will be latched off. The active low nFAULT output will be enabled. The latch can be reset by commanding $\overline{\text{SLEEP}}$ or $\overline{\text{RESET}}$ low, or by bringing VBB below its UVLO threshold.

THERMAL OR UNDERVOLTAGE FAULT SHUTDOWN

In the event of a fault, overtemperature (excess T_j) or an undervoltage (on VCP), the FET outputs of the A5984 are disabled until the fault condition is removed. At power-on, the UVLO (undervoltage lockout) circuit disables the FET outputs and resets the translator to the Home state.

OVERCURRENT PROTECTION

A current monitor will protect the IC from damage due to output shorts. If a short is detected, the IC will latch the fault and disable the outputs. The fault latch can only be cleared by coming out of Sleep mode or by cycling the power to VBB. During OCP events, Absolute Maximum Ratings may be exceeded for a short period of time before the device latches (see Figure 5).

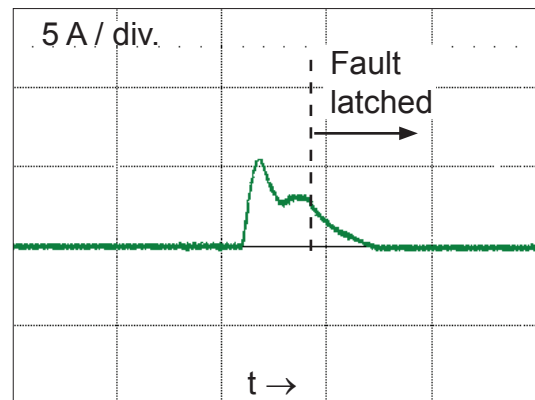

Figure 5: Overcurrent Event

APPLICATION INFORMATION

Layout

The printed circuit board should use a heavy groundplane. For optimum electrical and thermal performance, the A5984 must be soldered directly onto the board. On the underside of the A5984 package is an exposed pad, which provides a path for enhanced thermal dissipation. The thermal pad should be soldered directly to an exposed surface on the PCB. Thermal vias are used to transfer heat to other layers of the PCB (see Figure 6).

In order to minimize the effects of ground bounce and offset issues, it is important to have a low-impedance single-point ground, known as a *star ground*, located very close to the device. By making the connection between the pad and the ground plane directly under the A5984, that area becomes an ideal location for a star ground point. A low-impedance ground will prevent ground bounce during high-current operation and ensure that the supply voltage remains stable at the input terminal.

The two input capacitors should be placed in parallel, and as close to the device supply pins as possible (see Figure 8). The ceramic capacitor (C7) should be closer to the pins than the bulk capacitor (C2). This is necessary because the ceramic capacitor will be responsible for delivering the high-frequency current components.

The sense resistors, RSx, should have a very low-impedance path to ground, because they must carry a large current while supporting very accurate voltage measurements by the current sense comparators. Long ground traces will cause additional voltage drops, adversely affecting the ability of the comparators to accurately measure the current in the windings. The SENSEx pins have very short traces to the RSx resistors and very thick, low-impedance traces directly to the star ground underneath the device. If possible, there should be no other components on the sense circuits.

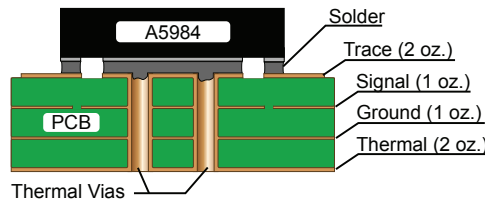

Figure 6: Soldering Cross-Section

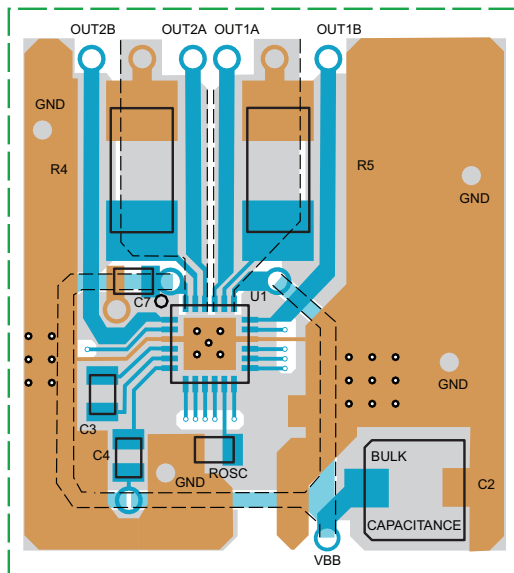

Figure 7: ES Package Circuit Layout

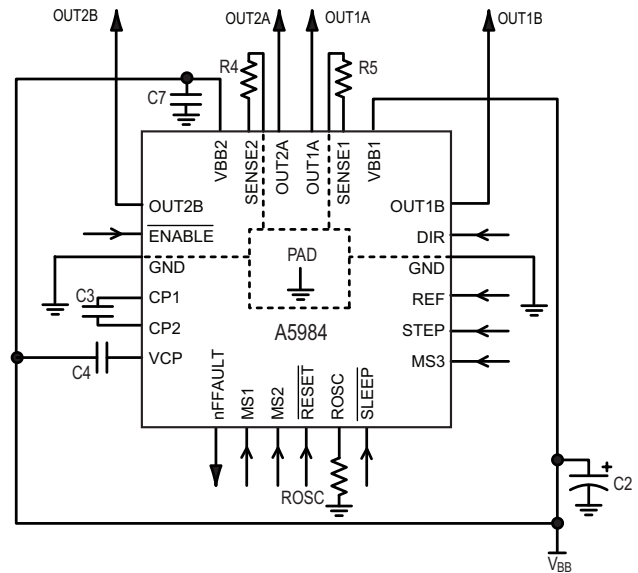

Figure 8: ES Package Typical Application

Pin Circuit Diagrams

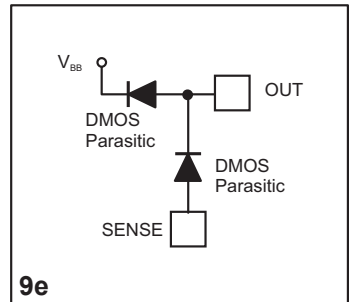
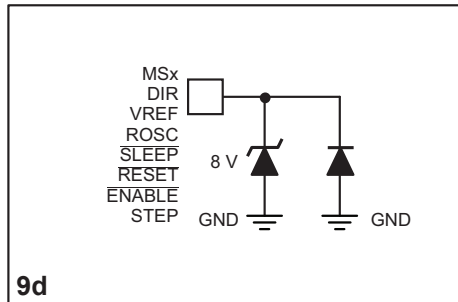
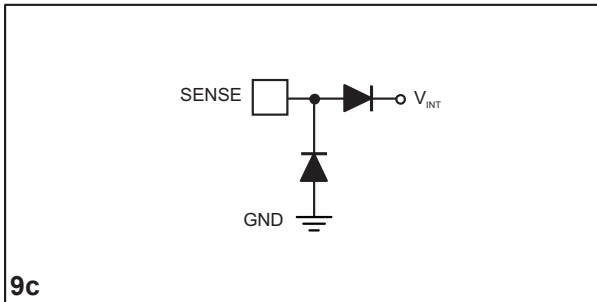
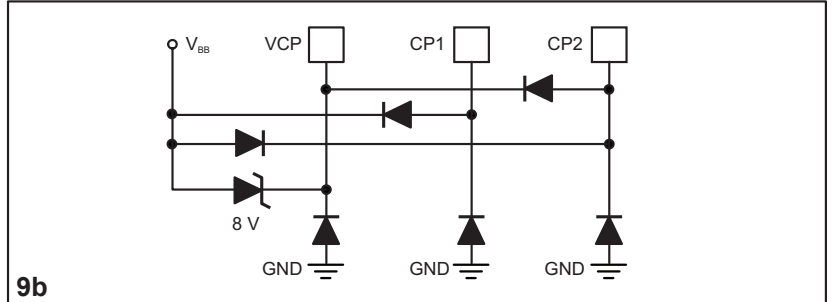
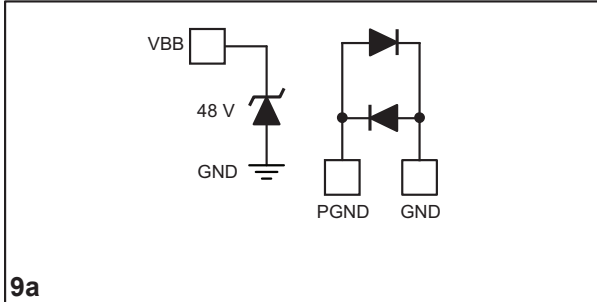

Figure 9: Pin Circuit Diagrams

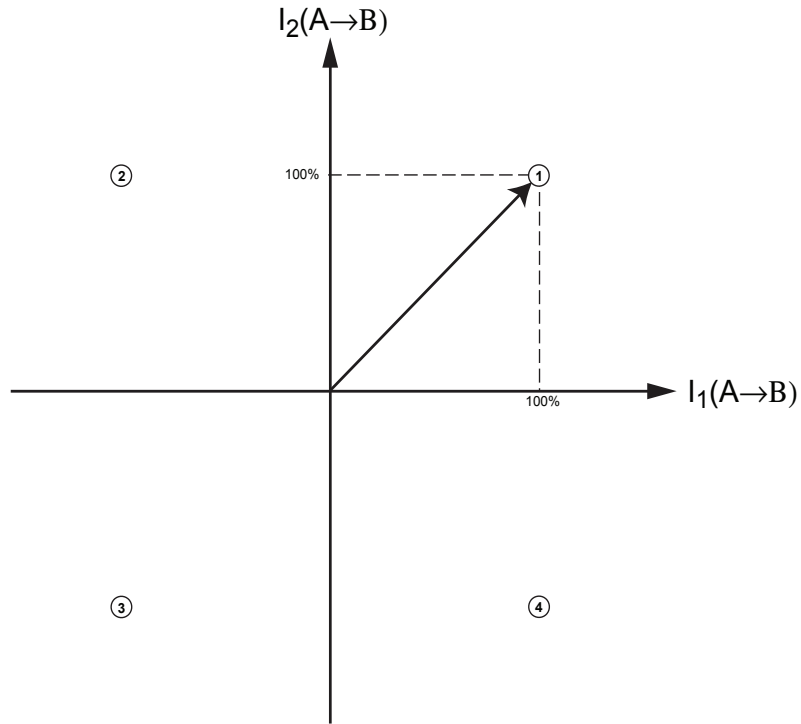

Figure 10: Full Step (100% Torque)
 MSX pins = 000. See Table 2 for step number detail

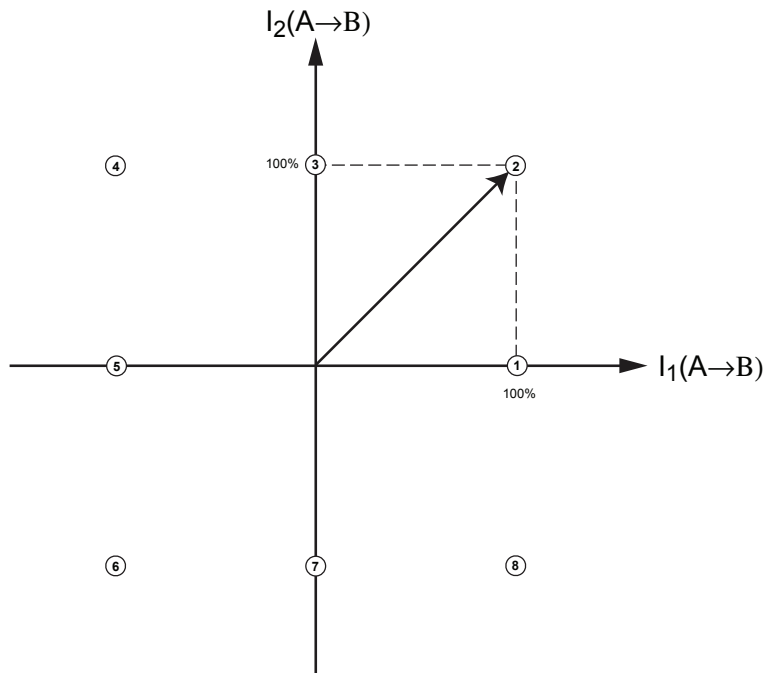

Figure 11: Half Step (100% Torque)
 MSX pins = 001. See Table 2 for step number detail

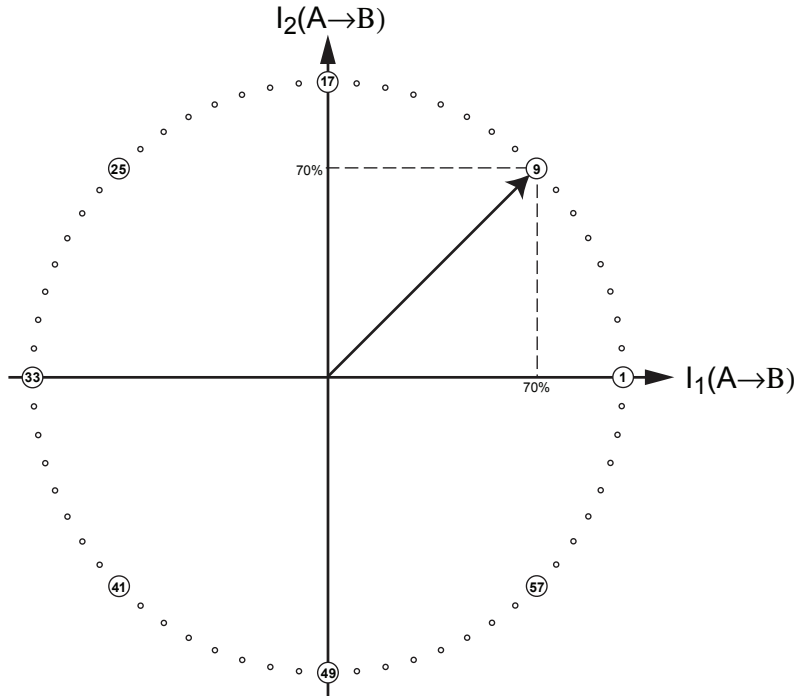

Figure 12: Sixteenth Step
MSX pins = 010. See Table 3 for step number detail

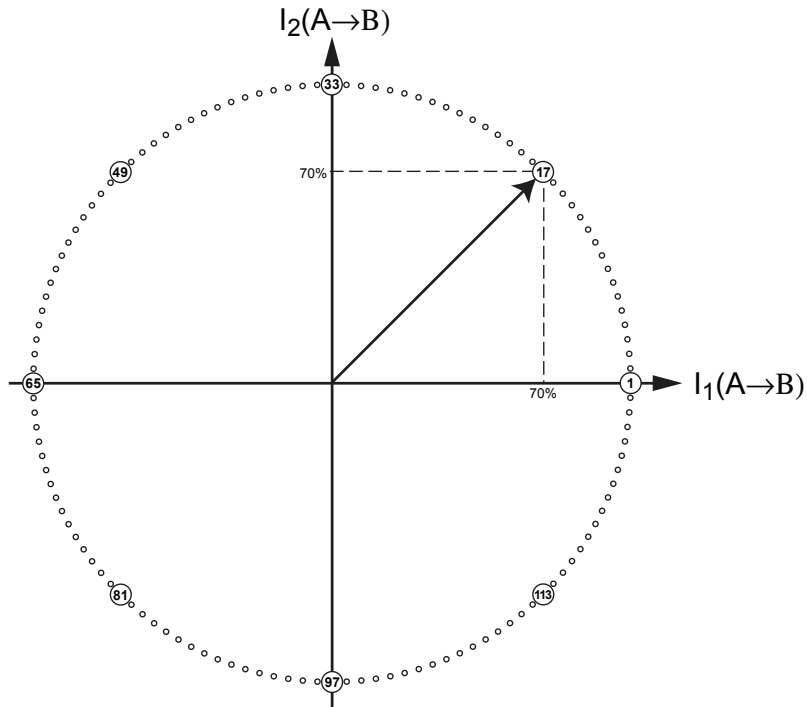

Figure 13: Thirty-Second Step
MSX pins = 011. See Table 3 for step number detail

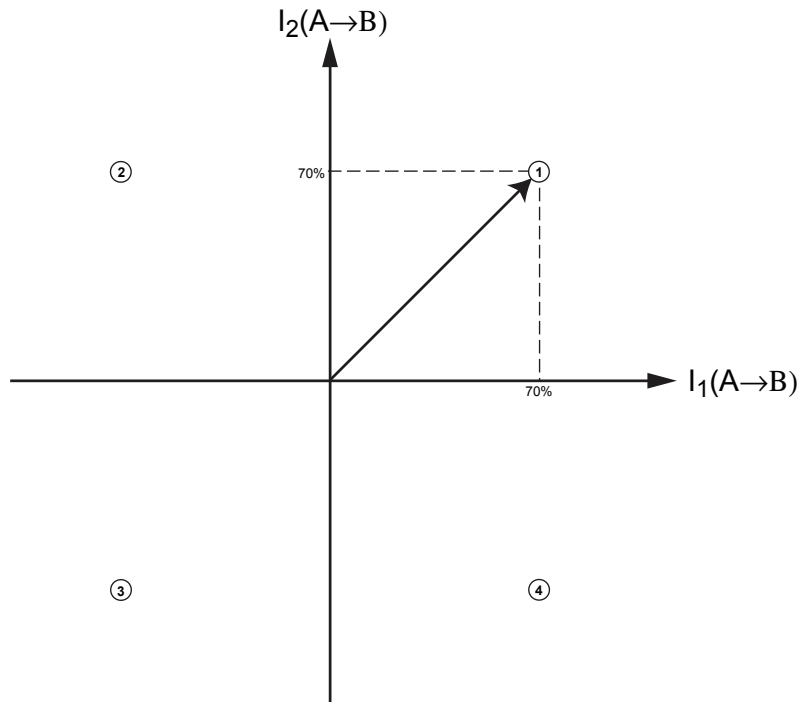

Figure 14: Full Step (70% Torque)
MSX pins = 100. See Table 3 for step number detail

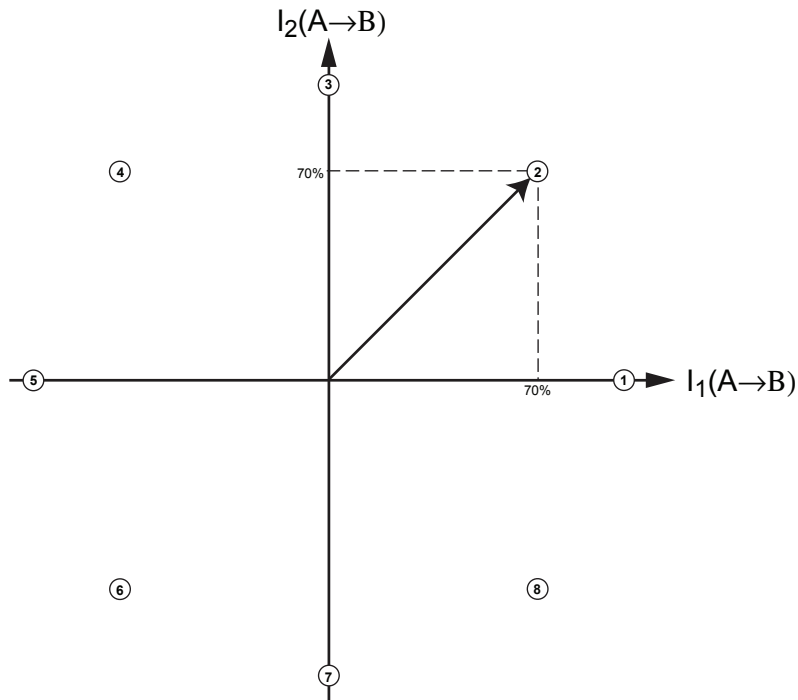

Figure 15: Half Step (70% Torque)
MSX pins = 101. See Table 3 for step number detail

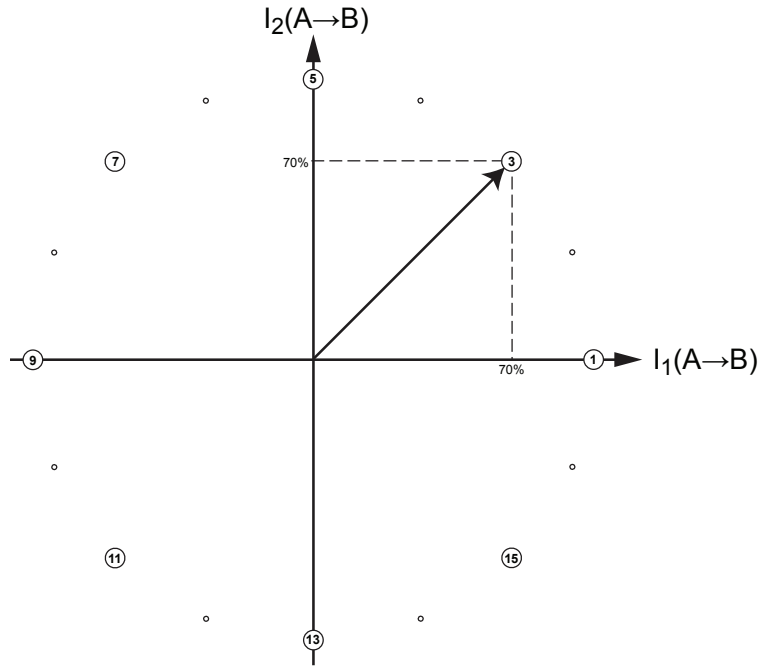

Figure 16: Quarter Step
 MSX pins = 110. See Table 3 for step number detail

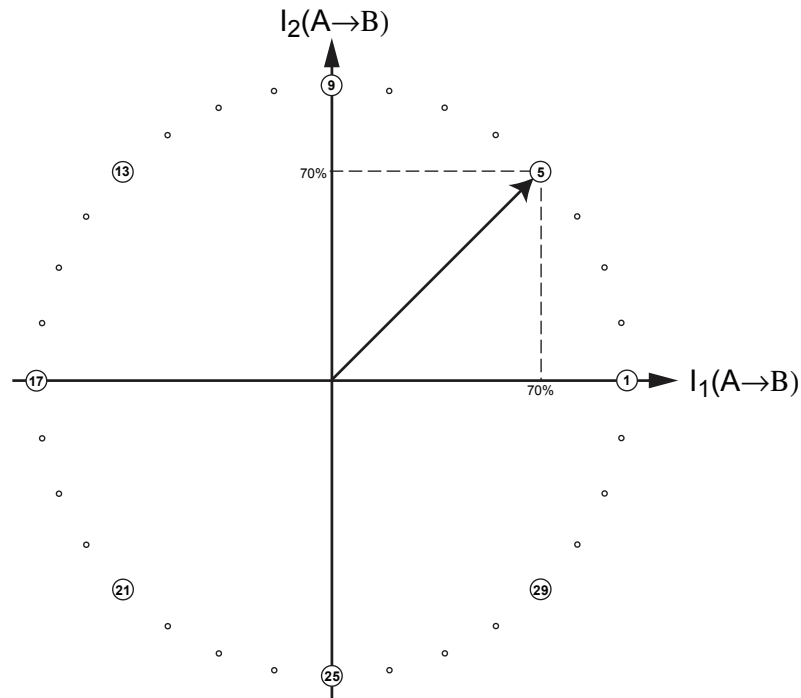

Figure 17: Eighth Step
 MSX pins = 111. See Table 3 for step number detail

Stepping Phase Tables**Table 2: Stepping Phase Table, Full Torque Modes**

Full (100%)	Half Step (100%)	Angle	Winding Current 1 (%)	Winding Current 2 (%)
	1	0	100	0
1	2	45	100	100
	3	90	0	100
2	4	135	-100	100
	5	180	-100	0
3	6	225	-100	-100
	7	270	0	-100
4	8	315	100	-100

Table 3: Stepping Phase Table, Common Modes

Full (70%)	Half (70%)	1/4 Step	1/8 Step	1/16 Step	1/32 Step	Angle	Winding Current 1 (%)	Winding Current 2 (%)
	1	1	1	1	1	0	100	0
					2	2.8	100	5
				2	3	5.6	100	10
					4	8.4	99	15
			2	3	5	11.3	98	20
					6	14.1	97	24
				4	7	16.9	96	29
					8	19.7	94	34
		2	3	5	9	22.5	92	38
					10	25.3	90	43
				6	11	28.1	88	47
			4	7	13	33.8	83	56
					14	36.6	80	60
				8	15	39.4	77	63
					16	42.2	74	67
1	2	3	5	9	17	45	71	71
					18	47.8	67	74
				10	19	50.6	63	77
					20	53.4	60	80
			6	11	21	56.3	55	83
					22	59.1	51	86
				12	23	61.9	47	88
					24	64.7	43	90
		4	7	13	25	67.5	38	92
					26	70.3	34	94
				14	27	73.1	29	96
					28	75.9	24	97
			8	15	29	78.8	19	98
					30	81.6	15	99
				16	31	84.4	10	100
					32	87.2	5	100
	3	5	9	17	33	90	0	100

Continued on the next page...

Stepping Phase Table, Common Modes (continued)

Full (70%)	Half (70%)	1/4 Step	1/8 Step	1/16 Step	1/32 Step	Angle	Winding Current 1 (%)	Winding Current 2 (%)
					34	92.8	-5	100
				18	35	95.6	-10	100
					36	98.4	-15	99
			10	19	37	101.3	-20	98
					38	104.1	-24	97
				20	39	106.9	-29	96
					40	109.7	-34	94
		6	11	21	41	112.5	-38	92
					42	115.3	-43	90
				22	43	118.1	-47	88
					44	120.9	-51	86
			12	23	45	123.8	-56	83
					46	126.6	-60	80
				24	47	129.4	-63	77
					48	132.2	-67	74
2	4	7	13	25	49	135	-71	71
					50	137.8	-74	67
				26	51	140.6	-77	63
					52	143.4	-80	60
			14	27	53	146.3	-83	55
					54	149.1	-86	51
				28	55	151.9	-88	47
					56	154.7	-90	43
		8	15	29	57	157.5	-92	38
					58	160.3	-94	34
				30	59	163.1	-96	29
					60	165.9	-97	24
			16	31	61	168.8	-98	19
					62	171.6	-99	15
				32	63	174.4	-100	10
					64	177.2	-100	5
	5	9	17	33	65	180	-100	0
					66	182.8	-100	-5

Continued on the next page...

Stepping Phase Table, Common Modes (continued)

Full (70%)	Half (70%)	1/4 Step	1/8 Step	1/16 Step	1/32 Step	Angle	Winding Current 1 (%)	Winding Current 2 (%)
				34	67	185.6	-100	-10
					68	188.4	-99	-15
			18	35	69	191.3	-98	-20
					70	194.1	-97	-24
				36	71	196.9	-96	-29
					72	199.7	-94	-34
		10	19	37	73	202.5	-92	-38
					74	205.3	-90	-43
				38	75	208.1	-88	-47
					76	210.9	-86	-51
			20	39	77	213.8	-83	-56
					78	216.6	-80	-60
				40	79	219.4	-77	-63
					80	222.2	-74	-67
3	6	11	21	41	81	225	-71	-71
					82	227.8	-67	-74
				42	83	230.6	-63	-77
					84	233.4	-60	-80
			22	43	85	236.3	-55	-83
					86	239.1	-51	-86
				44	87	241.9	-47	-88
					88	244.7	-43	-90
		12	23	45	89	247.5	-38	-92
					90	250.3	-34	-94
				46	91	253.1	-29	-96
					92	255.9	-24	-97
			24	47	93	258.8	-19	-98
					94	261.6	-15	-99
				48	95	264.4	-10	-100
					96	267.2	-5	-100
	7	13	25	49	97	270	0	-100
					98	272.8	5	-100

Continued on the next page...

Stepping Phase Table, Common Modes (continued)

Full (70%)	Half (70%)	1/4 Step	1/8 Step	1/16 Step	1/32 Step	Angle	Winding Current 1 (%)	Winding Current 2 (%)
				50	99	275.6	10	-100
					100	278.4	15	-99
			26	51	101	281.3	20	-98
					102	284.1	24	-97
				52	103	286.9	29	-96
					104	289.7	34	-94
		14	27	53	105	292.5	38	-92
					106	295.3	43	-90
				54	107	298.1	47	-88
					108	300.9	51	-86
			28	55	109	303.8	56	-83
					110	306.6	60	-80
				56	111	309.4	63	-77
					112	312.2	67	-74
4	8	15	29	57	113	315	71	-71
					114	317.8	74	-67
				58	115	320.6	77	-63
					116	323.4	80	-60
			30	59	117	326.3	83	-55
					118	329.1	86	-51
				60	119	331.9	88	-47
					120	334.7	90	-43
		16	31	61	121	337.5	92	-38
					122	340.3	94	-34
				62	123	343.1	96	-29
					124	345.9	97	-24
			32	63	125	348.8	98	-19
					126	351.6	99	-15
				64	127	354.4	100	-10
					128	357.2	100	-5

PACKAGE OUTLINE DRAWINGS

For Reference Only – Not for Tooling Use

(Reference JEDEC MO-220WGGD)

Dimensions in millimeters – NOT TO SCALE

Exact case and lead configuration at supplier discretion within limits shown

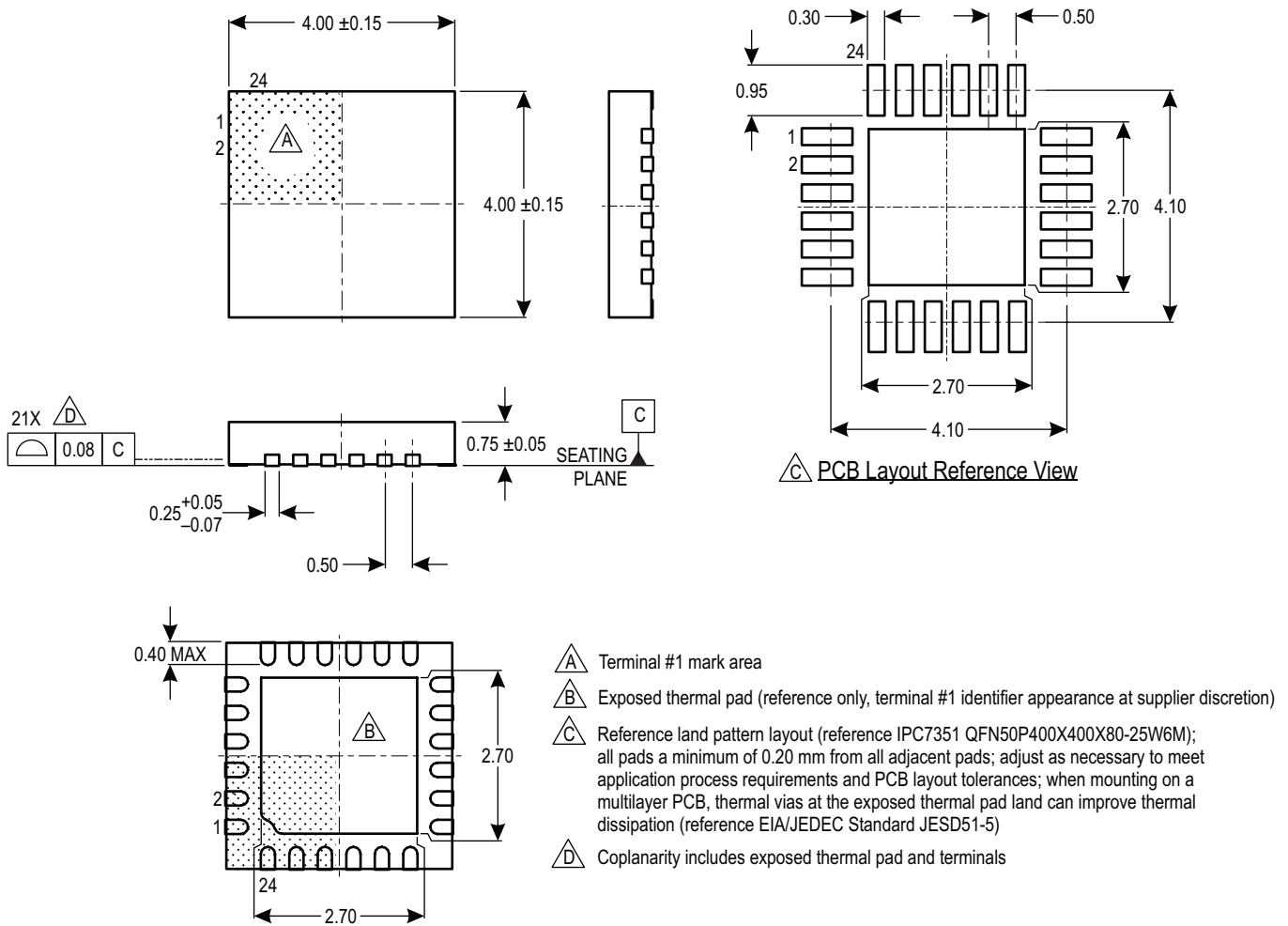

Figure 18: ES Package, 24-Pin QFN with Exposed Thermal Pad

For Reference Only – Not for Tooling Use

(Reference JEDEC MO-220VHHD-5)
 Dimensions in millimeters – NOT TO SCALE
 Exact case and lead configuration at supplier discretion within limits shown

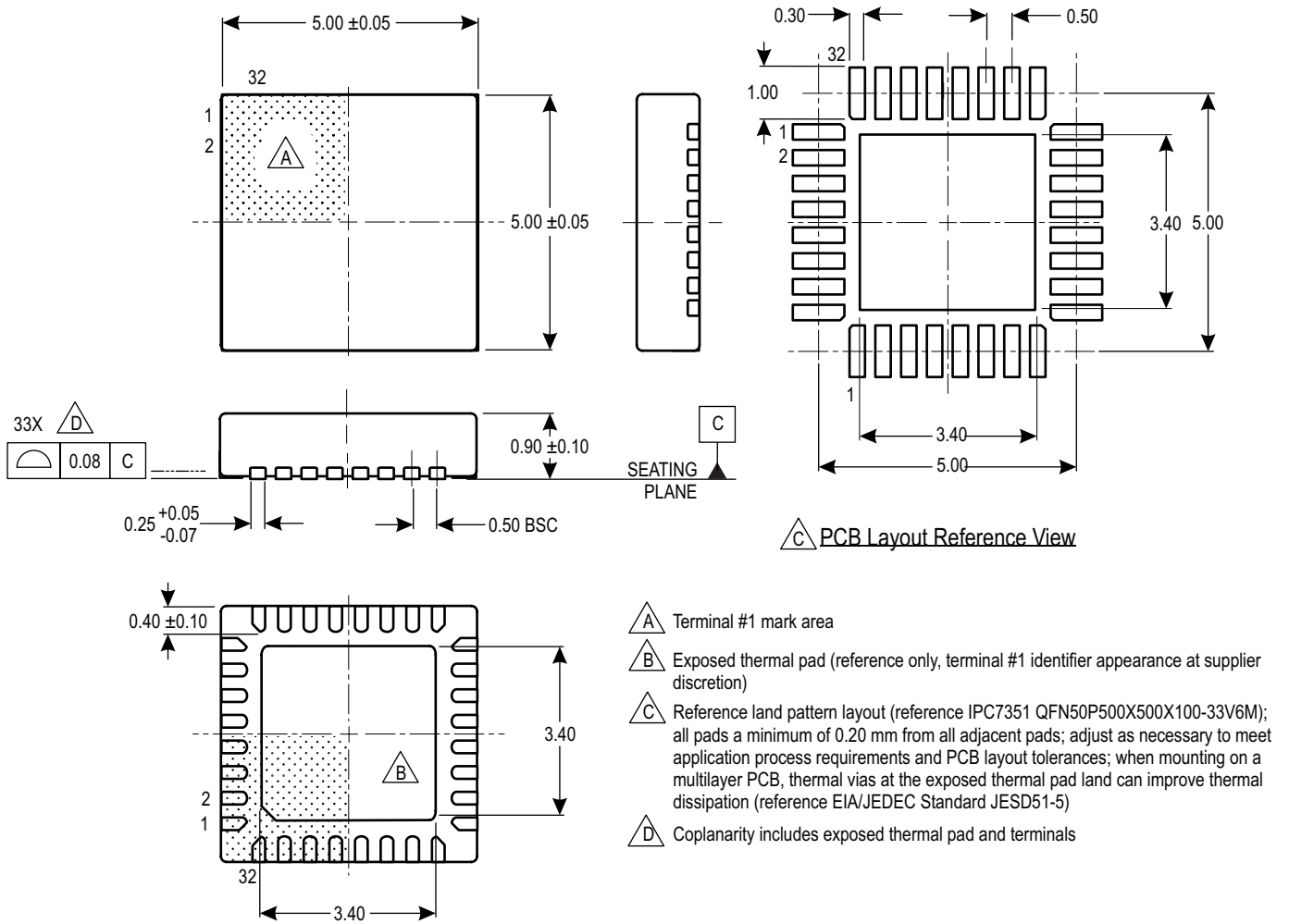

Figure 19: ET Package, 32-Pin QFN with Exposed Thermal Pad

For Reference Only – Not for Tooling Use

(Reference MO-153 ADT)

NOT TO SCALE

Dimensions in millimeters

Dimensions exclusive of mold flash, gate burrs, and dambar protrusions
Exact case and lead configuration at supplier discretion within limits shown

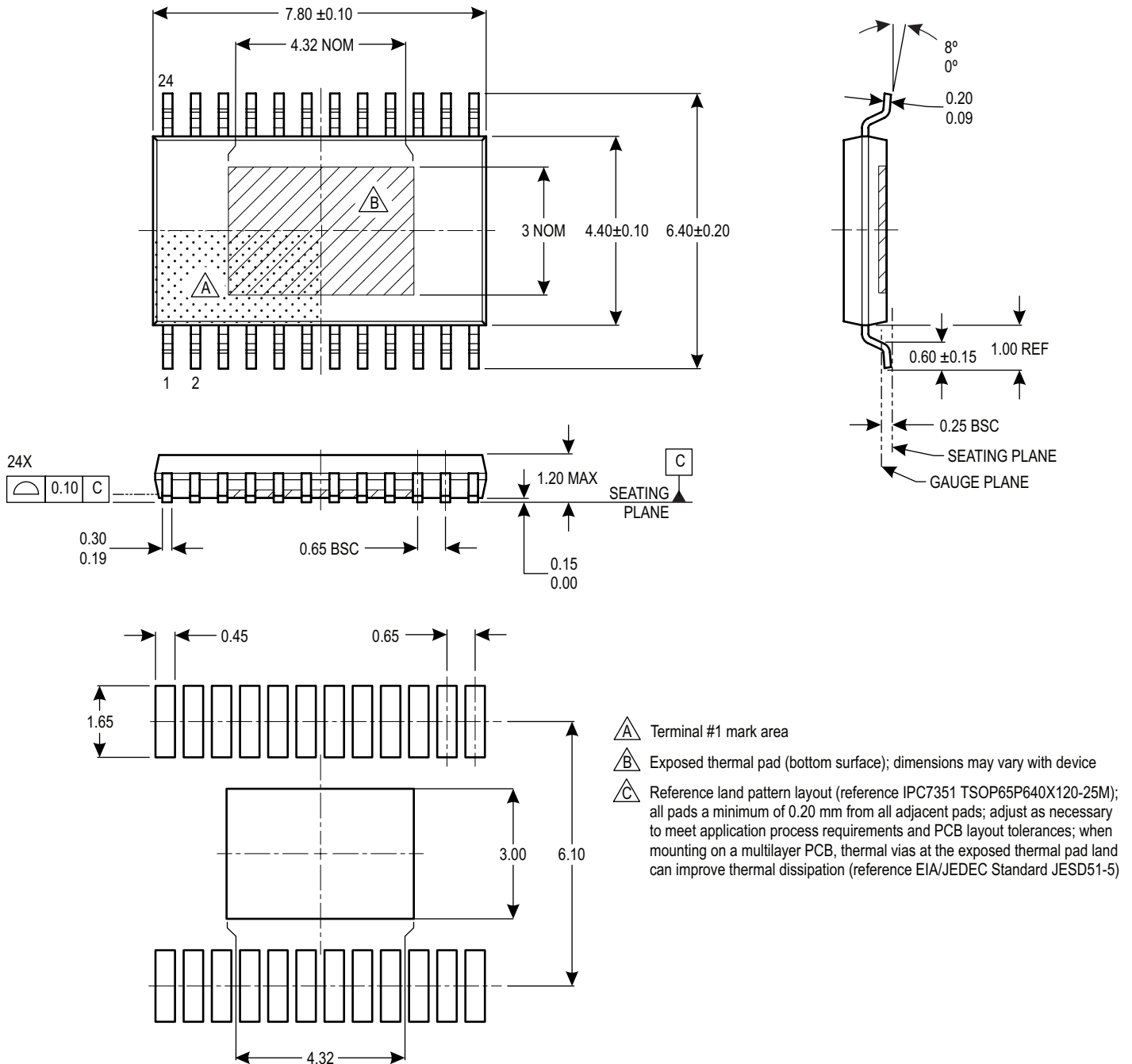

Figure 20: LP Package, 24-Pin TSSOP with Exposed Thermal Pad

REVISION HISTORY

Number	Date	Description
–	January 19, 2016	Initial release
1	April 26, 2016	Updated Pin Circuit Diagrams 9c and 9e on page 15
2	January 3, 2017	Added VBB UVLO and VBB UVLO Hysteresis characteristics to page 6

Copyright ©2017, Allegro MicroSystems, LLC

Allegro MicroSystems, LLC reserves the right to make, from time to time, such departures from the detail specifications as may be required to permit improvements in the performance, reliability, or manufacturability of its products. Before placing an order, the user is cautioned to verify that the information being relied upon is current.

Allegro's products are not to be used in any devices or systems, including but not limited to life support devices or systems, in which a failure of Allegro's product can reasonably be expected to cause bodily harm.

The information included herein is believed to be accurate and reliable. However, Allegro MicroSystems, LLC assumes no responsibility for its use; nor for any infringement of patents or other rights of third parties which may result from its use.

For the latest version of this document, visit our website:

www.allegromicro.com

