

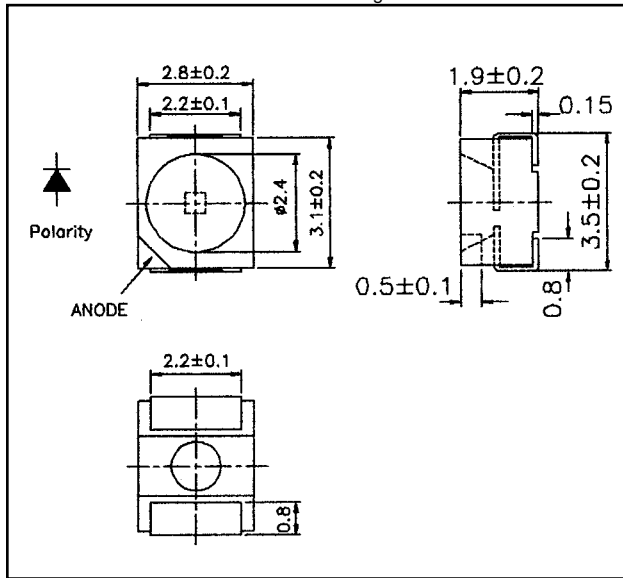

Weight: 2.0 Unit: mm



AND6BB

InGaN Ultra Bright Blue Light Emission Surface Mount Package

Features

- P-LCC-2 package with optical indicator
- Wide viewing angle
- Suitable for vapor-phase reflow, infrared reflow and wave solder processes
- Low current operation: 2 mA
- Ideal for (LCD) backlight & light pipe applications
- Compatible with automatic placement equipment

Maximum Ratings ($T_a = 25^\circ\text{C}$)

Characteristics	Symbol	Rating	Unit
Forward Current	I_F	30	mA
Reverse Voltage	V_R	5	V
Power Dissipation	P_D	120	mW
Operating Temperature Range	T_{Opr}	-45 to 85	$^\circ\text{C}$
Storage Temperature Range	T_{Stg}	-40 to 90	$^\circ\text{C}$

Product specifications contained herein may be changed without prior notice. It is therefore advisable to contact Purdy Electronics before proceeding with the design of equipment incorporating this product.

Electro-Optical Characteristics ($T_a = 25^\circ\text{C}$)

Characteristics	Symbol	Test Condition	Minimum	Typical	Maximum	Unit
Forward Voltage	V_F	$I_F = 20$ mA	–	3.5	4.3	V
Reverse Current	I_R	$V_R = 5$ V	–	–	10	μA
Luminous Intensity	I_V	$I_F = 20$ mA	25	37	–	mcd
Peak Emission Wavelength	I_P	$I_F = 20$ mA	–	468	–	nm
Spectral Line Half Width	$\Delta\lambda$	$I_F = 20$ mA	–	26	–	nm
Dominant Wavelength	λ_d	$I_F = 20$ mA	–	470	–	nm
Full Viewing Angle	2θ	$I_F = 20$ mA	–	120	–	degree

Precaution

Please be careful of the following:

1. Manual soldering: maximum temperature of iron tip: 260°C max.
Soldering time: within 5 sec. per solder-land
Soldering portion of lead: up to 1.6 mm from the body of the device
2. Reflow solder: recommended condition is as follows:

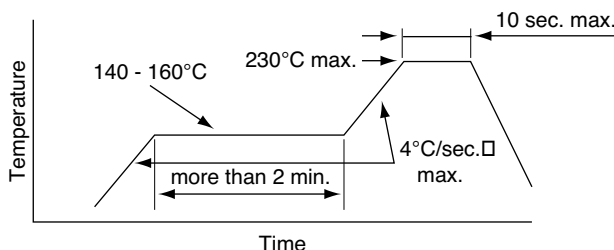

For reflow soldering

