

**BOA Shown Installed
In Line Between Two Patchcords and an Adapter**

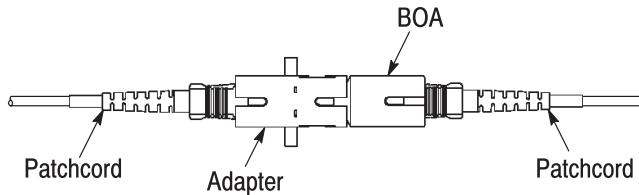

Figure 1

1. INTRODUCTION

Fiber optic BOAs are used to control power levels in fiber optic cable (or lines) used in telecommunication and CATV applications.

For application requirements for the BOAs, refer to Application Specification 114-1129.

NOTE All numerical values on this instruction sheet are in metric units [with U.S. customary units in brackets].

2. DESCRIPTION

Configured as a connector with a plug (or ferrule) at one end and a receptacle at the other end, the BOA can be installed at a distribution patch panel, in line between two patchcords and an adapter (shown in Figure 1), or directly at the receiver interface. BOAs, like patchcords, are available with ends that thread, snap, or twist to fully connect.

3. INSTALLATION

The following steps describe installation of the BOA in line between two patchcords and an adapter; basically, the same steps apply to installation at a distribution patch panel and installation directly at the receiver interface.

DANGER Never look into the end of a patchcord or BOA when the connecting ends of the fiber optic cable are attached to an optical power source. Infrared light is invisible but can damage eye tissue.

1. Identify the line to be attenuated. Disconnect the patchcord from the adapter.
2. Remove the protective cover from the plug end of the BOA.
3. Inspect and, *if necessary*, clean the end face of the BOA and the end face of the patchcord according to Section 4.

CAUTION IT IS EXTREMELY IMPORTANT that ALL end faces are clean BEFORE mating.

4. Align the plug end of the BOA with one end of the adapter, and insert the BOA into the adapter. Refer to Figure 2, Detail A. Make sure that the BOA is fully connected. For a BOA with threaded ends, finger-tighten the BOA to a torque of approximately 0.23 N-m [2 in.-lb].

NOTE For BOAs with a key, make sure that the key is aligned with the key slot of the adapter.

CAUTION To avoid damage to the adapter, patchcord, or BOA, DO NOT use any tools to tighten the BOA.

5. Remove the protective cover from the receptacle end of the BOA.
6. Inspect and, *if necessary*, clean the end face of the BOA and the end face of the patchcord according to Section 4.

CAUTION IT IS EXTREMELY IMPORTANT that ALL end faces are clean BEFORE mating.

7. Align the end face of the patchcord with the receptacle end of the BOA, and insert the patchcord into the BOA. Refer to Figure 2, Detail B. Make sure that the patchcord is fully connected. For a patchcord with threaded ends, finger-tighten the patchcord to a torque of approximately 0.23 N-m [2 in.-lb].

NOTE For BOAs with a key slot, make sure that the key of the patchcord is aligned with the key slot of the BOA.

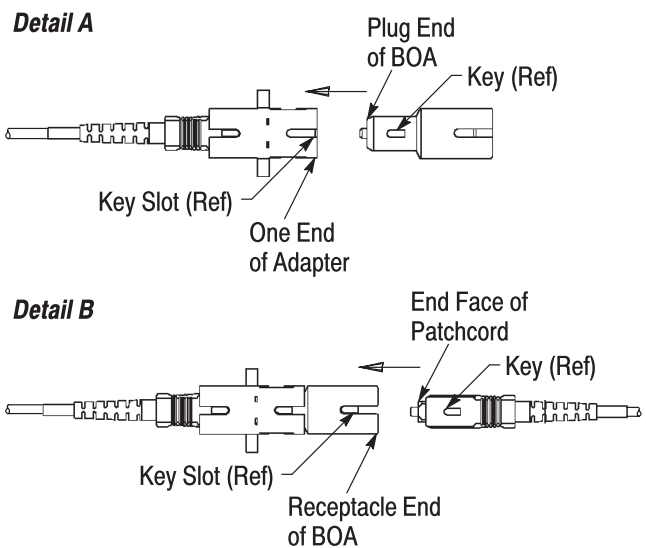

Figure 2

4. INSPECTION AND CLEANING

Cleanliness of the fiber optic interface is extremely important for system performance. It is recommended that all end faces be inspected and clean BEFORE installing (or mating) the BOA according to the following procedure.

The following tools and materials are necessary for inspection and cleaning the end faces of the BOA and any mating connectors. Follow the operating instructions packaged with the tools and safety guidelines packaged with the materials.

— TEXWIPE TX604 TechniCloth™ wipers or dry, lint-free cloths

— fiber optic reel cleaner with cassette

NOTE

In some cases, static charge from wipers or cloths attracts dust particles and prevents the end face from becoming clean. The fiber optic reel cleaner will eliminate static buildup while cleaning the end face.

— TEXWIPE TX759B MicroAbsorbant™ swabs or equivalent

— isopropyl alcohol (99% reagent grade) or equivalent alcohol fiber wipes

— fiber optic inspection microscope with magnification of 200×, probe, and probe tip appropriate for application (SC, FC, ST, or D4)

— clean dry air (filtered laboratory or canned)

4.1. Plug End of BOA and Mating Connector (If Able to Be Disconnected)

1. Using the microscope, inspect each end face for contamination. If contamination is not present on either of the end faces, mate the BOA and the mating connector immediately to prevent contamination. If contamination is present, proceed with the following steps for each contaminated end face.

2. Place a wiper (or dry, lint-free cloth) on a smooth, flat, hard surface.

3. Holding the plug end of the BOA or connector perpendicular (with end face facing down) to the wiper, wipe the end face across the wiper using a short, quick motion.

NOTE

Wiping too delicately will not adequately clean the end face.

4. Blow clean dry air over the end face.

5. Using the microscope, inspect the end face again to make sure that all contamination is removed. If not:

a. Moisten a wiper (or dry, lint-free cloth) with the isopropyl alcohol (or use an alcohol fiber wipe), and wipe the end face using a back-and-forth motion.

b. Wipe the end face with a wiper (or dry, lint-free cloth) to remove any alcohol residue. If the wiper is not effective, use the reel cleaner.

c. Blow clean dry air over the end face.

6. Repeat these steps, as necessary, until the end face is clean.

CAUTION

IT IS EXTREMELY IMPORTANT that ALL end faces are clean BEFORE mating.

4.2. Receptacle End of BOA and Mating Connector (If Not Able to Be Disconnected)

1. Using the microscope with the probe and appropriate probe tip installed, inspect each end face for contamination. If contamination is not present on either of the end faces, mate the BOA and mating connector immediately to prevent contamination. If contamination is present, proceed with the following for each contaminated end face:

2. Insert a swab into the receptacle end of the BOA or into the connector until it touches the end face.

3. Carefully rotate the swab in one direction, sweep it back and forth, then pull it out. Discard the swab.

CAUTION

DO NOT RE-USE A SWAB. A used swab can contaminate the end face.

4. Repeat these steps, as necessary, until the end face is clean.

CAUTION

IT IS EXTREMELY IMPORTANT that ALL end faces are clean BEFORE mating.

5. REVISION SUMMARY

- Updated document to incorporate requirements
- Deleted part number in Section 1, INTRODUCTION