

High Brightness LED Driver IC

FEATURES

- Battery operation : 3 V to 15 V
- Output current range : 0 A to a few Amperes depending on rating of external NMOS and mode of operation
- Current mode control architecture
- LED dimming function available by using PWM signal
- 32 mV / 202 mV reference voltage
- Low standby current
- Configurable as either Boost / Buck-Boost / Buck mode converter
- Built-in various protection circuit : Under voltage lock out
Over voltage protection
Soft start function
- 16 pin Plastic Quad Flat Non-leaded Package (QFN Type)

DESCRIPTION

AN30888B is a Boost / Buck-Boost / Buck DCDC controller that drives an external power NMOS switch. It is suitable for driving high brightness LED for LED lighting applications.

APPLICATIONS

- LED lighting module
- LED lantern applications
- White LED backlighting for LCD panel
- White LED flash light driving applications
- General LED back lighting

TYPICAL APPLICATION

Buck-Boost Mode

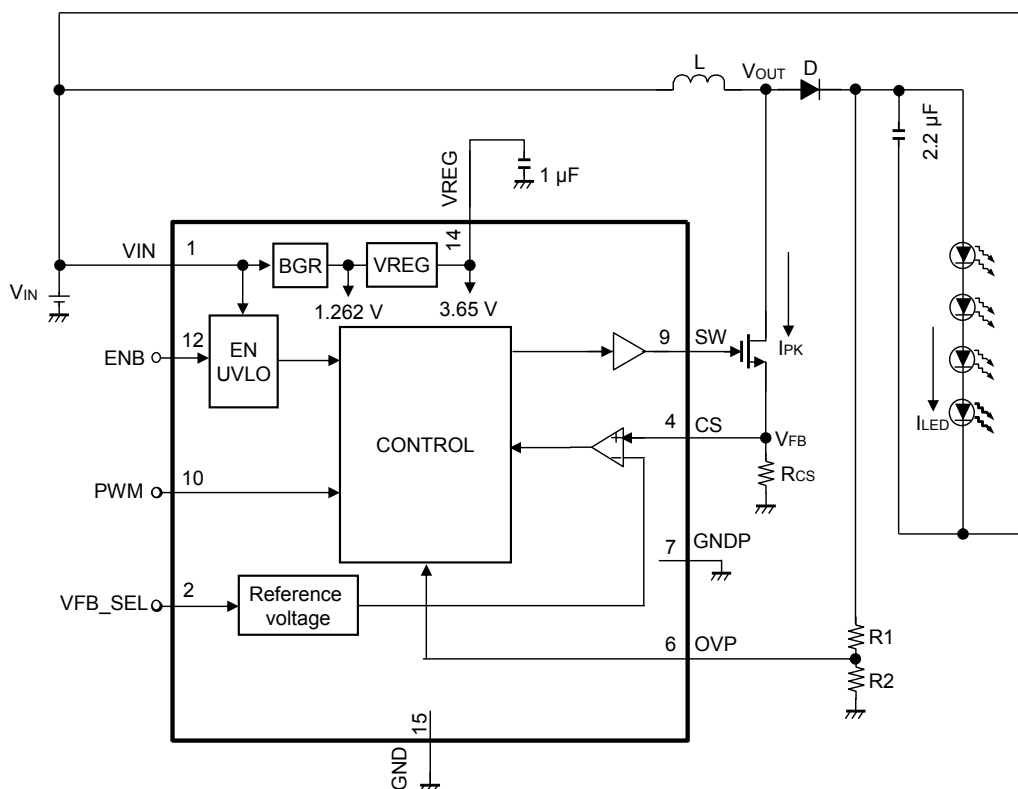

Notes : This application circuit is an example. The operation of the mass production set is not guaranteed. Customers shall perform enough evaluation and verification on the design of mass production set. Customers shall be fully responsible for the incorporation of the above application circuit and information in the design of the equipment.

TYPICAL APPLICATION (Continued)

Boost Mode

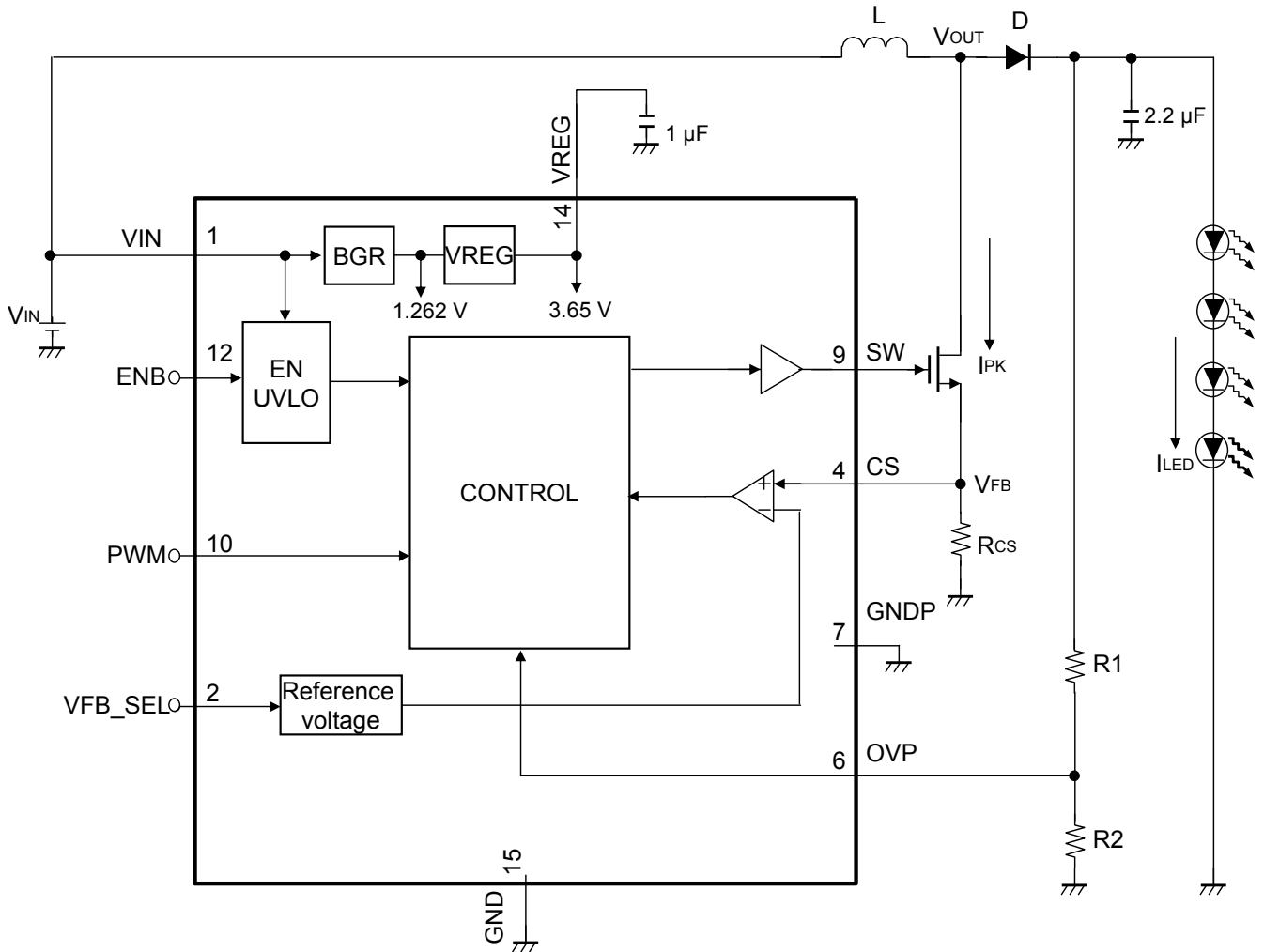

Note)

This application circuit is an example. The operation of the mass production set is not guaranteed. Customers shall perform enough evaluation and verification on the design of mass production set. Customers shall be fully responsible for the incorporation of the above application circuit and information in the design of the equipment.

TYPICAL APPLICATION (Continued)

Buck Mode

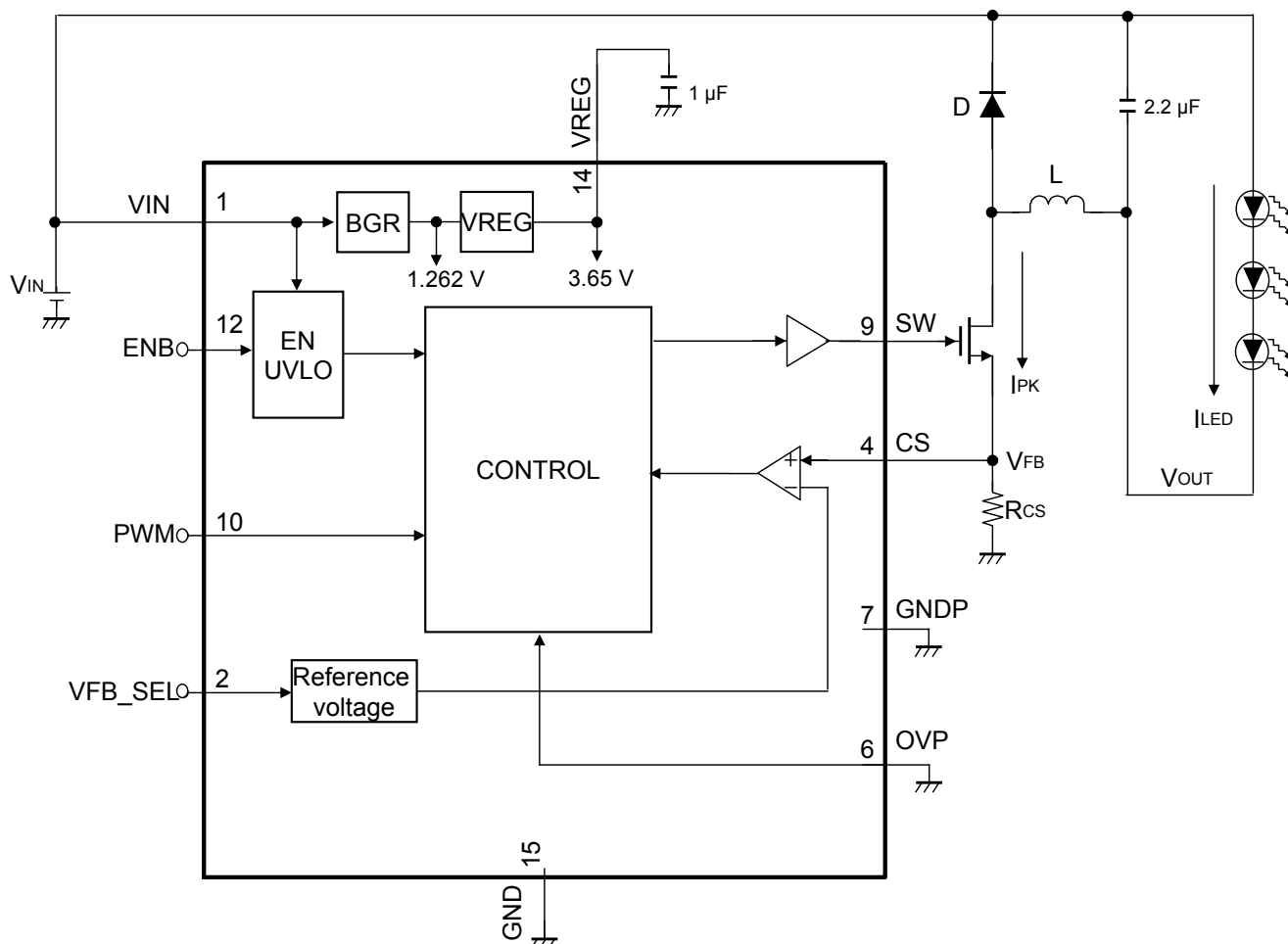

Note)

This application circuit is an example. The operation of the mass production set is not guaranteed. Customers shall perform enough evaluation and verification on the design of mass production set. Customers shall be fully responsible for the incorporation of the above application circuit and information in the design of the equipment.

ABSOLUTE MAXIMUM RATINGS

Parameter	Symbol	Rating	Unit	Note
Supply voltage	V_{IN}	15.5	V	*1
Output Current	I_{OUT}	—	mA	*1
Operating ambience temperature	T_{opr}	- 25 to + 85	°C	*2
Operating junction temperature	T_j	- 25 to + 125	°C	*2
Storage temperature	T_{stg}	- 55 to + 125	°C	*2
Input Voltage Range	V_{CS}, V_{OVP}	- 0.3 to 4.3	V	—
	V_{FB_SEL}, V_{PWM}	- 0.3 to 5.5	V	—
	V_{ENB}	- 0.3 to 15.5	V	—
Output Voltage Range	V_{SW}, V_{REG}	- 0.3 to 4.3	V	—
ESD	HBM	1.5 to 2.0	kV	—

Note) This product may sustain permanent damage if subjected to conditions higher than the above stated absolute maximum rating. This rating is the maximum rating and device operating at this range is not guaranteeable as it is higher than our stated recommended operating range. When subjected under the absolute maximum rating for a long time, the reliability of the product may be affected.

*1: $V_{IN} = VIN$.

The values under the condition not exceeding the above absolute maximum ratings and the power dissipation.

*2: Except for the power dissipation, operating ambient temperature, and storage temperature, all ratings are for $T_a = 25^\circ\text{C}$.

POWER DISSIPATION RATING

PACKAGE	θ_{JA}	PD (Ta=25 °C)	PD (Ta=85 °C)
16 pin Plastic Quad Flat Non-leaded Package (QFN Type)	189.2 °C / W	0.529 W	0.212 W

Note) For the actual usage, please refer to the P_D - T_a characteristics diagram in the package specification, supply voltage, load and ambient temperature conditions to ensure that there is enough margin follow the power and the thermal design does not exceed the allowable value.



CAUTION

Although this LSI has built-in ESD protection circuit, it may still sustain permanent damage if not handled properly. Therefore, proper ESD precautions are recommended to avoid electrostatic damage to the MOS gates.

RECOMMENDED OPERATING CONDITIONS

Parameter	Symbol	Min.	Typ.	Max.	Unit	Note
Supply voltage range	VIN1 (Boost Mode / Buck – Boost Mode)	3	6	12	V	*1
	VIN2 (Buck Mode)	3	6	15	V	*1
Input Voltage Range	V _{CS} , V _{OVP}	- 0.3	—	VREG	V	*2
	VFB_SEL, V _{PWM}	- 0.3	—	5.2	V	—
	V _{ENB}	- 0.3	—	VIN1 or VIN2	V	*2
Output Voltage Range	V _{SW}	- 0.3	—	5.2	V	—
	VREG	- 0.3	—	4.0	V	—

Note) *1: The values under the condition not exceeding the above absolute maximum ratings and the power dissipation.

Do not apply external currents and voltages to any pin not specifically mentioned.

Voltage values, unless otherwise specified, are with respect to GND. GND is voltage for GND and GNDP.

VIN1 and VIN2 are voltage for VIN.

*2: VREG V must not be exceeded 4.3 V. VIN1 V and VIN2 V must not be exceeded 15.5 V.

ELECTRICAL CHARACTERISTICS

$V_{IN} = 6\text{ V}$, $ENB = 6\text{ V}$, $PWM = V_{REG}$

Note) $T_a = 25\text{ }^\circ\text{C} \pm 2\text{ }^\circ\text{C}$ unless otherwise specified.

Parameter	Symbol	Condition	Limits			Unit	Note
			Min	Typ	Max		
Circuit Current Consumption							
Standby Current	I_{STB}	$ENB = 0\text{ V}$	—	—	10	μA	—
Operating Quiescent Current	I_{CC}	$ENB = V_{IN}$ No load condition	—	—	1	mA	—
ENABLE (ENB), VFB_SEL, ENABLE (ENB), VFB_SEL and PWM Control Function							
ENB High Input Logic	V_{ENBH}	—	3	—	V_{IN}	V	—
ENB Low Input Logic	V_{ENBL}	—	0	—	0.3	V	—
VFB_SEL High Input Logic	$V_{VFBSELH}$	—	$0.7 \times V_{REG}$	—	5	V	—
VFB_SEL Low Input Logic	$V_{VFBSELL}$	—	0	—	$0.3 \times V_{REG}$	V	—
PWM High input Logic	V_{PWMH}	—	$0.7 \times V_{REG}$	—	5	V	—
PWM Low input Logic	V_{PWML}	—	0	—	$0.3 \times V_{REG}$	V	—
Input Pin Current Consumption							
Enable Pin Current	I_{ENB}	$ENB = 6\text{ V}$	—	—	25	μA	—
Output Driver							
SW High Output Logic	V_{SWH}	SW output High logic; MOSFET ON condition	$0.7 \times V_{REG}$	—	$V_{REG} + 0.2$	V	—
SW Low Output Logic	V_{SWL}	SW output Low logic; MOSFET OFF condition	-0.2	—	0.2	V	—
Under Voltage Lock Out (UVLO)							
Under Voltage protection on value	V_{UVLOON}	V_{IN} Falling SW OFF; $V_{REG} = \text{no load}$	1.9	2.1	2.3	V	—
Under voltage protection Hysteresis	$V_{UVLOHYS}$	V_{IN} Rising SW ON , V_{IN} Falling SW OFF; $V_{REG} = \text{no load}$	0.1	0.3	0.5	V	—

ELECTRICAL CHARACTERISTICS

$V_{IN} = 6\text{ V}$, $ENB = 6\text{ V}$, $PWM = V_{REG}$

Note) $T_a = 25\text{ °C} \pm 2\text{ °C}$ unless otherwise specified.

Parameter	Symbol	Condition	Limits			Unit	Note
			Min	Typ	Max		
Reference Voltage Control							
VFB Reference Voltage 1	V_{VFB1}	VFB_SEL = High OVP = 0 V Buck mode)	—	202	—	mV	*1
VFB Reference Voltage 2	V_{VFB2}	VFB_SEL = Low OVP = 0 V (Buck mode)	—	32	—	mV	*1
Over Voltage Protection (Boost Mode , Buck-Boost mode Only)							
Over Voltage Protection Threshold	V_{OVP}	$R1 = 470\text{ k}\Omega$, $R2 = 30\text{ k}\Omega$	—	21	—	V	*1 *2
Output Driver							
Driver Off Time	T_{OFF}	Fix off time at SW pin	0.5	1	2	μs	—
Maximum Operating Frequency	F_{Max}	—	—	1.2	—	MHz	*1
Regulator Voltage (VREG)							
VREG Output Voltage	V_{REG}	$4\text{ V} \leq V_{IN} \leq 20\text{ V}$ No Load Condition, $CVREG = 1\text{ }\mu\text{F}$	—	3.65	—	V	*1
Efficiency							
Efficiency	Eff	$V_{IN} = 6\text{ V}$ 1 LED of $V_F = 3.7\text{ V}$ $I_{LED} = 400\text{ mA}$ VFB_SEL = High OVP = 0 V (Buck mode)	—	90	—	%	*1

Note) *1 : Typical design value

*2 : See OPERATION (Functions and properties descriptions) (9) Over Voltage Protection (OVP)

PIN CONFIGURATION

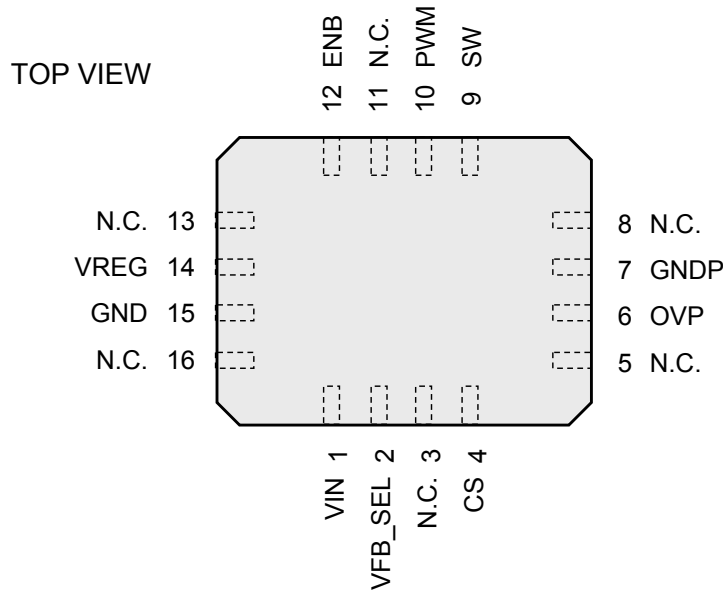

PIN FUNCTIONS

Pin No.	Pin name	Type	Description
1	VIN	Power Supply	Power Supply of LSI
2	VFB_SEL	Input	Feedback voltage select pin. Connect VFB_SEL to VREG pin for operation in 202 mV mode. Connect VFB_SEL to GND for operation in 32 mV mode
4	CS	Input	Current Sense pin. Connect a resistor to this pin to set the required LED current
6	OVP	Input	Over Voltage Protection input pin for Boost mode Connect to GND for Buck mode
7	GNDP	Ground	Power Ground
9	SW	Output	External NMOS Transistor Gate Drive
10	PWM	Input	PWM Dimming Control. Input clock pulse of high level = VREG and low level = GND LED current can be reduced according to the duty of this clock pulse to create dimming effect
12	ENB	Input	Standby On/Off Control. Connect ENB pin to VIN for Standby off Connect ENB pin to GND for Standby on
14	VREG	Output	Regulated Output voltage. This is internal driver voltage. Connect a 1 uF capacitor to this pin for regulator stability
15	GND	Ground	Ground
3,5,8,11,13,16	N.C.	—	—

FUNCTIONAL BLOCK DIAGRAM

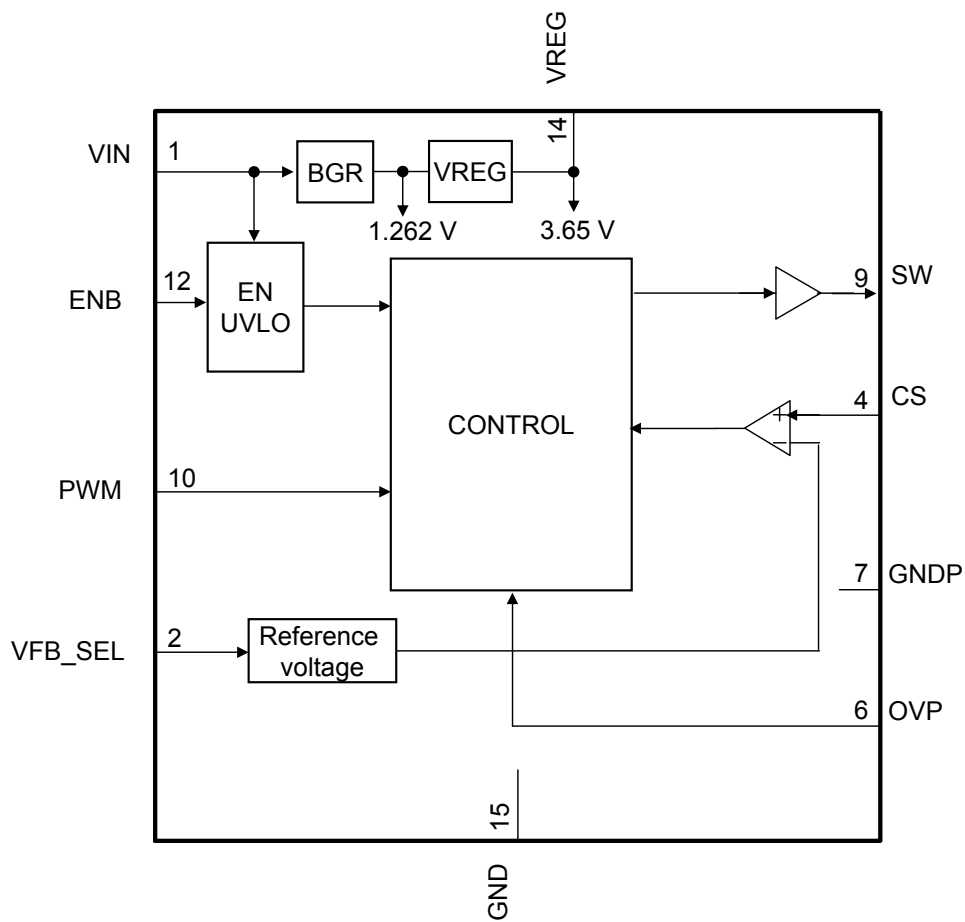

Notes: This block diagram is for explaining functions. Part of the block diagram may be omitted, or it may be simplified.

OPERATION

Functions and properties descriptions

(1) Overview

AN30888B is a constant current LED driver. The LSI works as a Boost /Buck-Boost/ Buck mode DCDC controller with external MOSFET.

Operating input voltages ranges from 3 V to 15 V. The mode of operation depends on the number of LEDs to be driven and the supply voltage level.

In general, please adhere to the following:

If total LED voltage drop is more than supply voltage, boost mode is adopted. If LED voltage drop is less than the supply voltage, buck mode is adopted. If supply voltage is close to the total LED voltage drop, the Buck-Boost mode can be used. Please note that the different mode of operation should be manually configured.

Output LED current can be designed ranges from 0 A and to a few amperes depending on the mode of operation, the external MOSFET characteristic and feasible R_{CS} value used. The control architecture uses current mode fix off time control. The V_{FB} reference voltage determines LED current by setting VFB_SEL pin with values of 32 mV or 202 mV under buck mode. By applying V_{FB} voltage of 32 mV, user can achieve higher efficiency with lower power dissipation in R_{CS} resistor. Applying 202 mV V_{FB} voltage achieves better LED current accuracy.

(2) Standby enable function

AN30888B enters standby mode when ENB pin is pulled low. During standby, the LSI draws a small current of value less than 10 μ A from the power supply. This helps to achieve longer battery usage time. During Boost mode operation, although external MOSFET cannot be turned on at standby condition, there is still a DC current path between the input and the LEDs through the inductor and schottky diode. Thus it is important to make sure that during boost mode, the minimum forward voltage of the LED array must exceed the maximum input voltage to ensure the LEDs remain off during standby mode.

OPERATION (continued)

Functions and properties descriptions (continued)

(3) Internal regulator

An internal 3.65 V regulator is used as the power supply for internal core circuit of this LSI.

This regulated voltage, V_{REG} will be provided when V_{IN} is approximately in the range of 4 V to 15V. For V_{IN} lower than 4 V, regulator will act as a V_{IN} voltage follower, with output voltage close to V_{IN} . The amount of drop voltage from V_{IN} during V_{IN} follower mode depends on load current of the regulator and also tolerance of the LSI. In general, the regulator output voltage will be approximately 0.3 V lower than V_{IN} during this mode of operation.

This regulator requires a capacitor of 1 μ F to be connected to VREG pin. This capacitor helps to provide a stable regulated voltage to the LSI. The regulator has a current ability of approximately 15 mA. However, it is not designed to provide as external power supply voltage. Hence an external load exceeding approximately 0.5 mA to the VREG pin is not allowed.

(4) Output setting consideration

The output voltage, V_{OUT} is set using the following equations for both boost and buck mode:

$$V_{OUT} = (V_F \times N_{LEDs} + V_D) \dots\dots\dots \text{Eq[1]} \quad (\text{Boost mode})$$

$$V_{OUT} = (V_{IN} - V_F \times N_{LEDs}) \dots\dots\dots \text{Eq[2]} \quad (\text{Buck mode})$$

$$V_{OUT} = (V_F \times N_{LEDs} + V_D + V_{IN}) \dots\dots\dots \text{Eq[3]} \quad (\text{Buck-Boost mode})$$

- V_{IN} : Battery or Input power supply voltage
- V_F : LED forward drop voltage
- N_{LEDs} : Number of LEDs stacked in series
- V_D : Schottky diode forward drop voltage

For Boost mode or Buck-Boost mode operation, V_{OUT} setting should be lesser than Drain–Source breakdown voltage of external MOSFET as mention in (11). Also V_{OUT} should be lesser than OVP protection threshold as mentioned in (9).

For Buck mode operation, V_{OUT} setting should give sufficient voltage for external MOSFET to operate properly at the required output current setting.

OPERATION (continued)

Functions and properties descriptions (continued)

(5) Feedback voltage V_{FB} at CS pin

The V_{FB} voltage is generated internally in the LSI and output at CS pin. This voltage allows users to fix the input peak current, I_{PK} as well as the LED output current, I_{LED} . This voltage will change according to the setting at VFB_SEL pin.

For operation in boost mode/buck-boost mode, V_{FB} will be inversely proportionally to supply voltage, V_{IN} . When input supply voltage decreases, V_{FB} will increase. This ensure LED current remain accurate as supply voltage decreases.

When operating in buck mode, V_{FB} voltage will remain at 202 mV or 32 mV depending on whether VFB_SEL pin is high or low.

The following are some figures of V_{FB} voltage with respect to V_{IN} . For detail information, please refer to graph and data table information as the following.

For Boost mode and Buck-Boost mode :

$V_{FB} = 116 \text{ mV}$	(When VFB_SEL = High ; $V_{IN} = 6 \text{ V}$)
$V_{FB} = 50 \text{ mV}$	(When VFB_SEL = Low ; $V_{IN} = 6 \text{ V}$)
$V_{FB} = 198.3 \text{ mV}$	(When VFB_SEL = Low ; $V_{IN} = 3 \text{ V}$)
$V_{FB} = 88 \text{ mV}$	(When VFB_SEL = Low ; $V_{IN} = 3 \text{ V}$)

For Buck mode :

$V_{FB} = 202 \text{ mV}$	(When VFB_SEL = High, for all V_{IN} level)
$V_{FB} = 32 \text{ mV}$	(When VFB_SEL = Low, for all V_{IN} level)

To improve overall efficiency V_{FB} voltage can be set lower by switching VFB_SEL = Low. On the other hand accuracy can be improved by using VFB_SEL = High mode.

OPERATION (continued)

Functions and properties descriptions (continued)

(5) Feedback voltage V_{FB} at CS pin (continued)

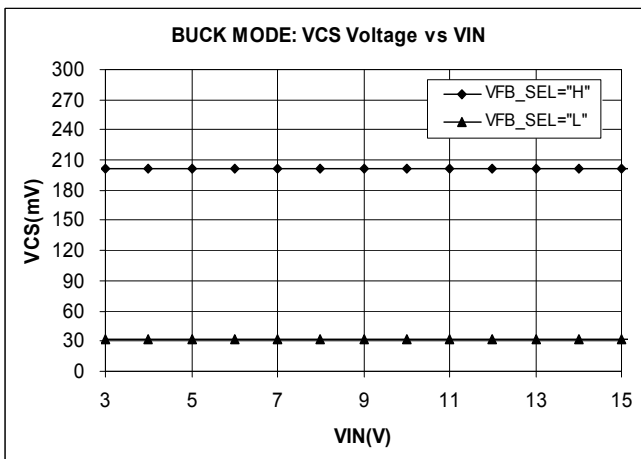
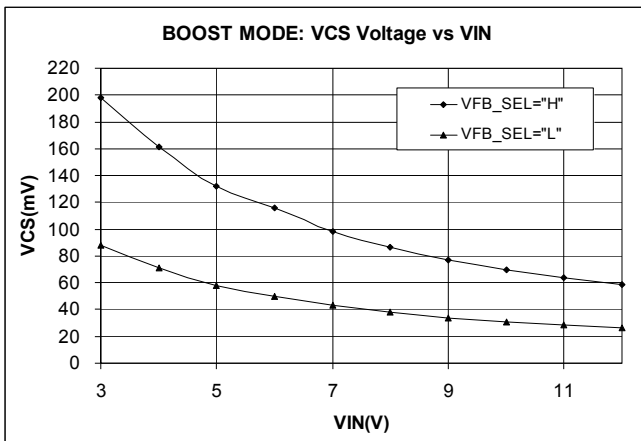

V_{IN} (V)	Boost mode Buck-Boost mode		Buck mode	
	VFB_SEL = High	VFB_SEL = Low	VFB_SEL = High	VFB_SEL = Low
	V_{FB} (mV)	V_{FB} (mV)	V_{FB} (mV)	V_{FB} (mV)
3	198.3	88.0	202	32
4	161.0	71.0	202	32
5	132.3	57.7	202	32
6	116.0	50.0	202	32
7	98.3	43.0	202	32
8	86.3	38.0	202	32
9	77.3	34.0	202	32
10	70.0	31.0	202	32
11	64.0	28.3	202	32
12	59.0	26.3	202	32
13	N.A	N.A	202	32
14	N.A	N.A	202	32
15	N.A	N.A	202	32

OPERATION (continued)

Functions and properties descriptions (continued)

(6) Inductor selection

Inductor value, L is set by the required inductor ripple current desired.

The general trend for lower inductor value is a smaller inductor physical size, but a larger input ripple current.

Similarly, an increase in inductor value will decrease input ripple current.

Users are advice to choose an inductor that can handle the peak current I_{PK} , flowing across it without saturating.

In addition, inductor with lower series resistance are preferred to provide better operating efficiency.

The following equation gives a general guideline in selection inductor value based on 30 % peak to peak ripple current across the inductor.

$$L = \frac{(V_{OUT} - V_{IN}) \times T_{OFF}}{0.3 \times I_{IN}} \dots\dots\dots \text{Eq[4]} \quad (\text{Boost mode, Buck-Boost mode})$$

$$L = \frac{(V_{IN} - V_{OUT}) \times T_{OFF}}{0.3 \times I_{LED}} \dots\dots\dots \text{Eq[5]} \quad (\text{Buck mode})$$

V_{OUT} = Output voltage

V_{IN} = Input supply voltage

T_{OFF} = Fixed off time design at 1 μ s

I_{LED} = LED output current

I_{IN} = Input current from supply voltage

Please note that the 0.3 factor can be altered if 30 % peak to peak current is changed.

i.e, if percentage of peak to peak current needed is 40 %, this factor will be 0.4.

OPERATION (continued)

Functions and properties descriptions (continued)

(7) Setting output LED current and choosing current sense resistor R_{CS}

The LED current in this LSI can be set easily by selecting the appropriate R_{CS} resistor to be used at CS pin of this chip.

For Boost Mode and Buck-Boost mode :

R_{CS} resistor can be set in the following way :

First is to calculate input current I_{IN} at the required operating condition :

$$I_{IN} = (V_{OUT} + V_D) \times (I_{LED} / V_{IN}) \dots\dots\dots \text{Eq[6]} \quad (\text{Boost mode, Buck-Boost mode})$$

- V_{OUT} = Output voltage
- V_D = Schottky diode forward drop voltage
- I_{LED} = Required LED current
- V_{IN} = Input supply voltage

After which the peak input current, I_{PK} can be determine by adding I_{IN} with half the peak to peak ripple current at the inductor.

$$I_{PK} = I_{IN} + \frac{(V_{OUT} - V_{IN}) \times T_{OFF}}{2L} \dots\dots\dots \text{Eq[7]} \quad (\text{Boost mode, Buck-Boost mode})$$

- T_{OFF} = Fixed off time = 1 μ s
- L = Inductor value found in part (6) inductor selection
- V_{OUT} = Output voltage
- V_{IN} = Input supply voltage
- I_{IN} = Input current found in Eq[6]

Lastly, R_{CS} resistor can be determine by using :

$$R_{CS} = \frac{V_{FB}}{I_{PK}} \dots\dots\dots \text{Eq[8]} \quad (\text{Boost mode, Buck-Boost mode})$$

- V_{FB} = Voltage at CS pin. Refer to data graphs for the V_{FB} voltage at different input voltage condition.
- I_{PK} = Peak current found in Eq[7]

Using numeric example of operating condition :

$$V_{IN} = 6 \text{ V}, V_{OUT} = 10 \text{ V}, I_{LED} = 500 \text{ mA}, T_{OFF} = 1 \mu\text{s}, L = 16 \mu\text{H}, V_D = 0.4 \text{ V}, V_{FB} = 0.1 \text{ V}@V_{IN} = 6 \text{ V}$$

$$\text{From Eq[6]} : I_{IN} = (10 + 0.4) \times (0.5 / 6) = 0.8667 \text{ A}$$

$$\text{From Eq[7]} : I_{PK} = 0.8667 + \frac{(10 - 6) \times 1 \mu}{2 \times 16 \mu} = 0.9971 \text{ A}$$

$$\text{From Eq[8]} : R_{CS} = \frac{0.1}{0.9917} = 100.8 \text{ m}\Omega$$

OPERATION (continued)

Functions and properties descriptions (continued)

(7) Setting output LED current and choosing current sense resistor R_{CS} (continued)

For Buck Mode :

R_{CS} resistor can be set in the following way :

First is to calculate the peak current I_{PK} using Eq[9]. During buck mode, peak current sense correspond to the average output LED current plus half of actual current ripple through the inductor.

$$I_{PK} = I_{LED} + \frac{(V_{IN} - V_{OUT}) \times T_{OFF}}{2L} \dots\dots\dots \text{Eq[9]} \quad (\text{Buck mode})$$

- V_{OUT} = Output voltage
- V_{IN} = Input supply voltage
- T_{OFF} = Fixed off time design at 1 μ s
- I_{LED} = LED output current
- L = Inductor value found in part (6) inductor selection

Lastly, R_{CS} resistor can be determine by using :

$$R_{CS} = \frac{V_{FB}}{I_{PK}} \dots\dots\dots \text{Eq[10]} \quad (\text{Buck mode})$$

- V_{FB} = Voltage at CS pin. Refer to data graphs for the V_{FB} voltage at different input voltage condition.
- I_{PK} = Peak current found in Eq[9] .

Using numeric example of operating condition :

$$V_{IN} = 12 \text{ V}, V_{OUT} = 2 \text{ V}, I_{LED} = 500 \text{ mA}, T_{OFF} = 1 \mu\text{s}, L = 66 \mu\text{H}, V_{FB} = 0.2 \text{ V}$$

$$\text{From Eq[9]} : I_{PK} = 0.5 + \frac{(12 - 2) \times 1 \mu}{2 \times 66 \mu} = 0.575 \text{ A}$$

$$\text{From Eq[10]} : R_{CS} = \frac{0.2}{0.575} = 348 \text{ m}\Omega$$

Please note that for component deviation such as inductor, diodes, etc, these deviation can cause the designed I_{PK} to be higher or lower than the calculated value.

Users may need to fine tune the value of R_{CS} from the calculated values in order to obtain accurate I_{LED} measurement.

Please take note of total impedance including parasitic impedance of PCB trace at CS pin to ground when designing the required R_{CS} value. This is especially important if the designed I_{LED} is high as R_{CS} value will be small and in turn making parasitic impedance significant to the total impedance seen at CS pin.

OPERATION (continued)

Functions and properties descriptions (continued)

(8) Soft start

Soft start circuit is incorporated into this LSI to avoid high in-rush current during start-up. After the device is enabled (ENB = High), the output inductor current and output voltage will rise slowly from initial condition. This slow start-up time ensure smooth start-up as well as minimize in-rush current.

(9) Over Voltage Protection (OVP)

When operating in Boost mode or Buck-Boost mode, over voltage protection is needed to prevent damages to LSI or external component damages in cases of open LED condition.

OVP switches off external power MOSFET to prevent output from rising over a designed OVP voltage. Output voltage should be limited to the rating of external component used. (for example Drain Source voltage rating of the external MOSFET or the output capacitor)

OVP compares the internal reference voltage of 1.26 V with output voltage through resistor network.

OVP threshold is set using the following equation:

$$V_{OVP} = \frac{1.262 \text{ V} \times (R1 + R2)}{R2} \dots\dots\dots \text{Eq}[11] \quad (\text{Boost mode, Buck-Boost mode})$$

If R1 = 470 kΩ, R2 = 30 kΩ, OVP threshold will be designed at around 21 V.

When OVP is triggered, output voltage will be clamped at this threshold voltage (with hysteresis of around 1 V to 2 V) until the fault (e.g open LED condition) has been removed.

When operating in buck mode, the OVP pin must be short to ground to disable this function as OVP function is not necessary in this mode.

OPERATION (continued)

Functions and properties descriptions (continued)

(10) Under Voltage Lock Out (UVLO)

Under Voltage lock out prevents LSI from operation at supply voltage lower than 2.1 V.

This function prevent LSI from abnormal operation when supply voltage V_{IN} drops below our recommended input range. When input voltage is lower than this lock out value of 2.1 V, external MOSFET will be switched off. When input voltage rises to 2.4 V or more, device operation starts again. This means a hysteresis voltage of about 0.3 V.

(11) Power MOSFET consideration

When selecting the power MOSFET, it is important to consider parameters such as gate-source, drain-source breakdown voltage, total gate capacitance, ON resistance and the drain current rating.

When power is turned on for LSI operating in boost mode, output voltage needed to drive LED will be reflected to Drain-Source voltage of the power MOSFET. Thus it is recommended to select a MOSFET that can handle this output voltage. Alternatively, output and Drain-Source voltage can be protected and clamped by OVP circuit as mentioned in point (9).

Gate capacitance of the MOSFET chosen should ideally to be smaller than 3 nF.

(12) PWM operation

PWM signal can be generated externally and input into PWM pin of this LSI. This PWM signal will turn on and off the output driver, giving an average output LED current that is proportional to the duty cycle of the PWM signal.

$$I_{LED(avg.)} = I_{LED} \times Duty \dots\dots\dots Eq[12] \quad (\text{Boost / Buck-Boost / Buck mode})$$

$I_{LED(avg.)}$ = The average output LED current after PWM is input

I_{LED} = The nominal LED current set in part (7)

Duty = The ratio of on pulse time compared to total period time of the PWM signal.

A PWM frequency of 1 kHz or lower is recommended to minimize error due to rise and fall time of the converter output.

OPERATION (continued)

Functions and properties descriptions (continued)

(13) Maximum duty operation

Maximum Duty limitation is needed when operating in Boost or Buck- Boost mode. This prevents the output voltage from having abnormal operation. For Buck mode, there is no need for maximum duty limit as SW pin is able to switch to 100% duty.

Please refer to the graph below for maximum duty vs V_{IN} data for Boost and Buck-Boost mode operation.

Boost/Buck-boost mode	
V_{IN} (V)	Duty Limit (%)
3.0	88.73
3.5	87.09
4.0	85.27
4.5	83.58
5.0	81.99
5.5	79.79
6.0	78.40
6.5	77.38
7.0	76.25
7.5	75.19
8.0	73.92
8.5	72.89
9.0	71.78
9.5	70.83
10.0	69.91
10.5	68.90
11.0	67.97
11.5	67.09
12.0	66.33

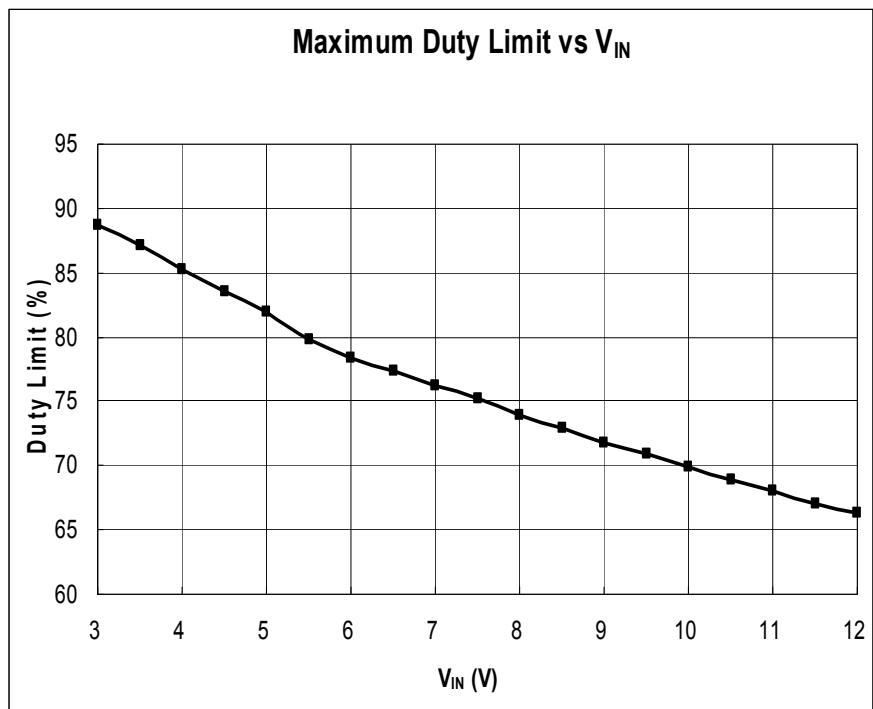

(14) Minimum duty operation

Parasitic circuit capacitance, inductance and external MOSFET gate drive current can create spike in the current sense, CS pin voltage at the point when external MOSFET is switched on. In order to prevent this spike to terminate the ON time prematurely, an internal filter of time constant, 100 ns is designed in chip. This time constant of 100 ns translates to a minimum duty of around 9% for all modes of operation. To further reduce the spike in the CS voltage especially when operating in low I_{LED} condition (example: R_{CS} is more than 0.8 Ω or more), external RC filter can be used in between V_{FB} node to CS pin which act as a low pass filter to filter spike noise from entering CS pin. This RC filter time constant should be long enough to reduce the parasitic spike without significantly affecting the shape of CS voltage.

The recommended RC value range from : $R = 10 \Omega$ to 1 k Ω and $C = 100 \text{ pF}$ to 500 pF depending on mode of operation and spike level.

PACKAGE INFORMATION (Reference Data)

Package Code: *QFN016-P-0304B

unit:mm

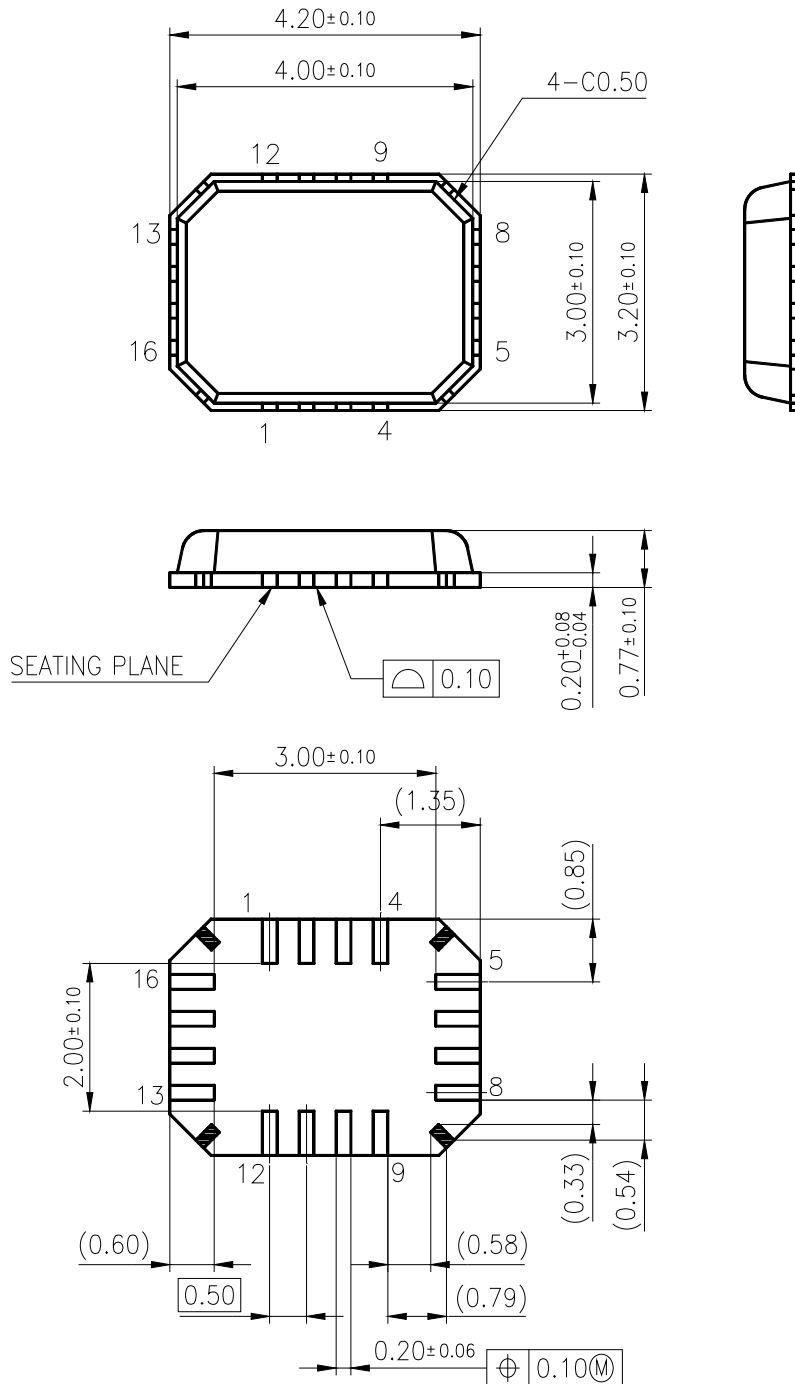

Body Material	: Epoxy Resin
Lead Material	: Cu Alloy
Bump	: Pd Plating

IMPORTANT NOTICE

1. When using the LSI for new models, verify the safety including the long-term reliability for each product.
2. When the application system is designed by using this LSI, please confirm the notes in this book.
Please read the notes to descriptions and the usage notes in the book.
3. Please use this product in compliance with all applicable laws and regulations that regulate the inclusion or use of controlled substances, including without limitation, the EU RoHS Directive. Our company shall not be held responsible for any damage incurred as a result of our LSI being used by our customers, not complying with the applicable laws and regulations.
4. Pay attention to the direction of LSI. When mounting it in the wrong direction onto the PCB (printed-circuit-board), it might emit smoke or ignite.
5. Pay attention in the PCB (printed-circuit-board) pattern layout in order to prevent damage due to short circuit between pins. In addition, refer to the Pin Description for the pin configuration.
6. Perform a visual inspection on the PCB before applying power, otherwise damage might happen due to problems such as a solder-bridge between the pins of the semiconductor device. Also, perform a full technical verification on the assembly quality, because the same damage possibly can happen due to conductive substances, such as solder ball, that adhere to the LSI during transportation.
7. Take notice in the use of this product that it might be damaged or occasionally emit smoke when an abnormal state occurs such as output pin-VCC short (Power supply fault), output pin-GND short (Ground fault), or output-to-output-pin short (load short). Safety measures such as an installation of fuses are recommended because the extent of the above-mentioned damage and smoke emission will depend on the current capability of the power supply..
8. This LSI is intended to be used for general electronic equipment.
Consult our sales staff in advance for information on the following applications: Special applications in which exceptional quality and reliability are required, or if the failure or malfunction of this LSI may directly jeopardize life or harm the human body.
Any applications other than the standard applications intended.
 - (1) Space appliance (such as artificial satellite, and rocket)
 - (2) Traffic control equipment (such as for automobile, airplane, train, and ship)
 - (3) Medical equipment for life support
 - (4) Submarine transponder
 - (5) Control equipment for power plant
 - (6) Disaster prevention and security device
 - (7) Weapon
 - (8) Others : Applications of which reliability equivalent to (1) to (7) is requiredOur company shall not be held responsible for any damage incurred as a result of or in connection with the LSI being used for any special application, unless our company agrees to the use of such special application.
9. This LSI is neither designed nor intended for use in automotive applications or environments unless the specific product is designated by our company as compliant with the ISO/TS 16949 requirements.
Our company shall not be held responsible for any damage incurred by customers or any third party as a result of or in connection with the LSI being used in automotive application, unless our company agrees to such application in this book.
10. The protection circuit is for maintaining safety against abnormal operation. Therefore, the protection circuit should not work during normal operation.
Especially for the thermal protection circuit, if the area of safe operation or the absolute maximum rating is momentarily exceeded due to output pin to VCC short (Power supply fault), or output pin to GND short (Ground fault), the LSI might be damaged before the thermal protection circuit could operate.
11. Unless specified in the product specifications, make sure that negative voltage or excessive voltage are not applied to the pins because the device might be damaged, which could happen due to negative voltage or excessive voltage generated during the ON and OFF timing when the inductive load of a motor coil or actuator coils of optical pick-up is being driven.
12. Product which has specified ASO (Area of Safe Operation) should be operated in ASO
13. Verify the risks which might be caused by the malfunctions of external components.

Request for your special attention and precautions in using the technical information and semiconductors described in this book

- (1) If any of the products or technical information described in this book is to be exported or provided to non-residents, the laws and regulations of the exporting country, especially, those with regard to security export control, must be observed.
- (2) The technical information described in this book is intended only to show the main characteristics and application circuit examples of the products. No license is granted in and to any intellectual property right or other right owned by Panasonic Corporation or any other company. Therefore, no responsibility is assumed by our company as to the infringement upon any such right owned by any other company which may arise as a result of the use of technical information described in this book.
- (3) The products described in this book are intended to be used for general applications (such as office equipment, communications equipment, measuring instruments and household appliances), or for specific applications as expressly stated in this book.
Consult our sales staff in advance for information on the following applications:
 - Special applications (such as for airplanes, aerospace, automotive equipment, traffic signaling equipment, combustion equipment, life support systems and safety devices) in which exceptional quality and reliability are required, or if the failure or malfunction of the products may directly jeopardize life or harm the human body.It is to be understood that our company shall not be held responsible for any damage incurred as a result of or in connection with your using the products described in this book for any special application, unless our company agrees to your using the products in this book for any special application.
- (4) The products and product specifications described in this book are subject to change without notice for modification and/or improvement. At the final stage of your design, purchasing, or use of the products, therefore, ask for the most up-to-date Product Standards in advance to make sure that the latest specifications satisfy your requirements.
- (5) When designing your equipment, comply with the range of absolute maximum rating and the guaranteed operating conditions (operating power supply voltage and operating environment etc.). Especially, please be careful not to exceed the range of absolute maximum rating on the transient state, such as power-on, power-off and mode-switching. Otherwise, we will not be liable for any defect which may arise later in your equipment.
Even when the products are used within the guaranteed values, take into the consideration of incidence of break down and failure mode, possible to occur to semiconductor products. Measures on the systems such as redundant design, arresting the spread of fire or preventing glitch are recommended in order to prevent physical injury, fire, social damages, for example, by using the products.
- (6) Comply with the instructions for use in order to prevent breakdown and characteristics change due to external factors (ESD, EOS, thermal stress and mechanical stress) at the time of handling, mounting or at customer's process. When using products for which damp-proof packing is required, satisfy the conditions, such as shelf life and the elapsed time since first opening the packages.
- (7) This book may be not reprinted or reproduced whether wholly or partially, without the prior written permission of our company.

Mouser Electronics

Authorized Distributor

Click to View Pricing, Inventory, Delivery & Lifecycle Information:

[Panasonic:](#)

[AN30888B-VB](#)