

FULL PAK™

High Voltage NPN Power Transistor

For Isolated Package Applications

The BUT11AF was designed for use in line operated switching power supplies in a wide range of end use applications. This device combines the latest state of the art bipolar fabrication techniques to provide excellent switching, high voltage capability and low saturation voltage.

- 1000 Volt V_{CES} Rating
- Low Base Drive Requirements
- Isolated Overmold Package
- Improved System Efficiency
- No Isolating Washers Required
- Reduced System Cost
- High Isolation Voltage Capability (4500 V_{RMS})

BUT11AF

POWER TRANSISTOR
5.0 AMPERES
450 VOLTS
40 WATTS

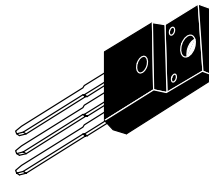

CASE 221D-02
TO-220 TYPE

MAXIMUM RATINGS

Rating	Symbol	Value	Unit
Collector–Emitter Sustaining Voltage	$V_{CEO(sus)}$	450	Vdc
Collector–Emitter Breakdown Voltage	V_{CES}	1000	Vdc
Emitter–Base Voltage	V_{EBO}	9.0	Vdc
RMS Isolation Voltage (For 1 sec, $T_A = 25^\circ\text{C}$, Rel. Humidity < 30%)	Per Figure 7 V_{ISOL1}	4500	V
	Per Figure 8 V_{ISOL2}	3500	
	Per Figure 9 V_{ISOL3}	2500	
Collector Current — Continuous — Pulsed (1)	I_C I_{CM}	5.0 10	Adc
Base Current — Continuous — Pulsed (1)	I_B I_{BM}	2.0 4.0	Adc
Total Power Dissipation @ $T_C = 25^\circ\text{C}$ * Derated above 25°C	P_D	40 0.32	Watts W/ $^\circ\text{C}$
Operating and Storage Temperature Range	T_J, T_{stg}	– 65 to +150	$^\circ\text{C}$

THERMAL CHARACTERISTICS

Thermal Resistance — Junction to Case*	$R_{\theta JC}$	3.125	$^\circ\text{C/W}$
Maximum Lead Temperature for soldering purposes 1/8" from case for 5 sec.	T_L	260	$^\circ\text{C}$

(1) Pulse Test: Pulse Width = 5.0 ms, Duty Cycle \leq 10%.

*Measurement made with thermocouple contacting the bottom insulated mounting surface of the package (in a location beneath the die), the device mounted on a heatsink, thermal grease applied, and a mounting torque of 6 to 8 in · lbs.

BUT11AF

ELECTRICAL CHARACTERISTICS ($T_C = 25^\circ\text{C}$ unless otherwise noted)

Characteristic	Symbol	Min	Typ	Max	Unit
----------------	--------	-----	-----	-----	------

OFF CHARACTERISTICS (1)

Collector-Emitter Sustaining Voltage (Figures 1 & 2) ($I_C = 100\text{ mA}$, $I_B = 0$, $L = 25\ \mu\text{H}$)	$V_{CE(sus)}$	450	–	–	Vdc
Collector Cutoff Current ($V_{CE} = 1000\text{ Vdc}$, $V_{BE} = 0$) ($V_{CE} = 1000\text{ Vdc}$, $V_{BE} = 0$, $T_J = 125^\circ\text{C}$)	I_{CES}	–	–	1.0 2.0	mAdc
Emitter-Base Leakage ($V_{EB} = 9.0\text{ Vdc}$, $I_C = 0$)	I_{EBO}	–	–	10	mAdc

ON CHARACTERISTICS (1)

Collector-Emitter Saturation Voltage ($I_C = 2.5\text{ Adc}$, $I_B = 0.5\text{ Adc}$)	$V_{CE(sat)}$	–	–	1.5	Vdc
Base-Emitter Saturation Voltage ($I_C = 2.5\text{ Adc}$, $I_B = 0.5\text{ Adc}$)	$V_{BE(sat)}$	–	–	1.5	Vdc
DC Current Gain ($I_C = 5.0\text{ mAdc}$, $V_{CE} = 5.0\text{ Vdc}$)	h_{FE}	10	–	–	–

DYNAMIC CHARACTERISTICS

Insulation Capacitance (Collector to External Heatsink)	C_{c-hs}	–	15	–	pF
---	------------	---	----	---	----

SWITCHING CHARACTERISTICS

Inductive Load (Figures 3 & 4)							
Storage	$I_C = 2.5\text{ Adc}$, $I_{B1} = 0.5\text{ Adc}$	$T_J = 25^\circ\text{C}$	t_s	–	1100	1400	ns
Fall Time			t_{fi}	–	80	150	
Storage		$T_J = 100^\circ\text{C}$	t_s	–	1200	1500	ns
Fall Time			t_{fi}	–	140	300	
Resistive Load (Figures 5 & 6)							
Turn-On Time	$I_C = 2.5\text{ Adc}$, $I_{B1} = I_{B2} = 0.5\text{ Adc}$	t_{on}	–	–	1000	ns	
Storage Time		t_s	–	–	4000		
Fall Time		t_f	–	–	800		

(1) Pulse Test: Pulse Width = 300 μs , Duty Cycle $\leq 2.0\%$.

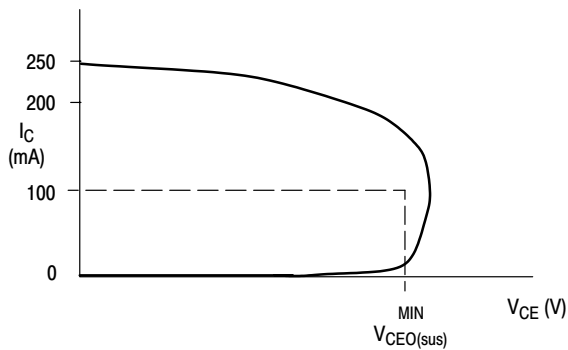

Figure 1. Oscilloscope Display for Sustaining Voltage

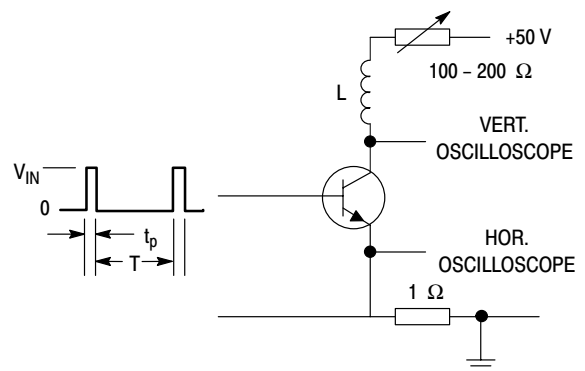

Figure 2. Test Circuit for $V_{CE(sus)}$

BUT11AF

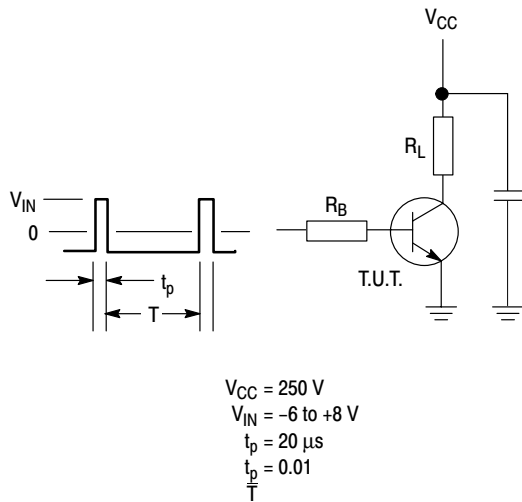

Figure 3. Test Circuit Resistive Load

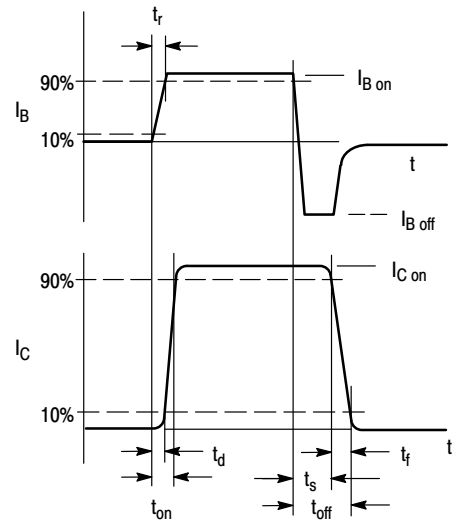

Figure 4. Switching Times Waveforms with Resistive Load

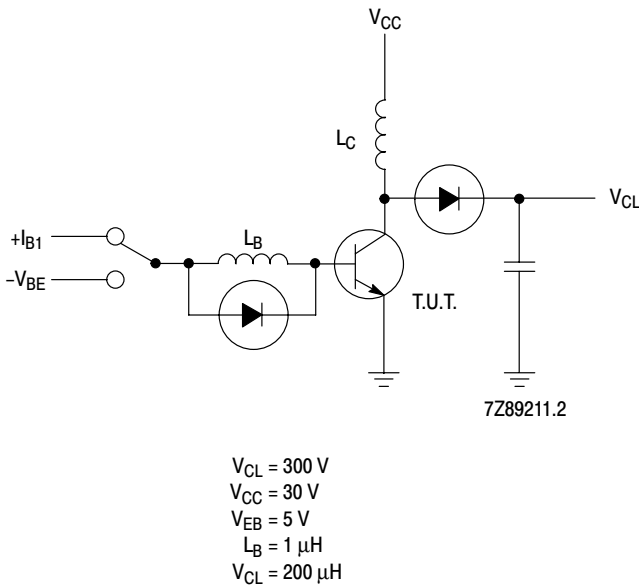

Figure 5. Test Circuit Inductive Load

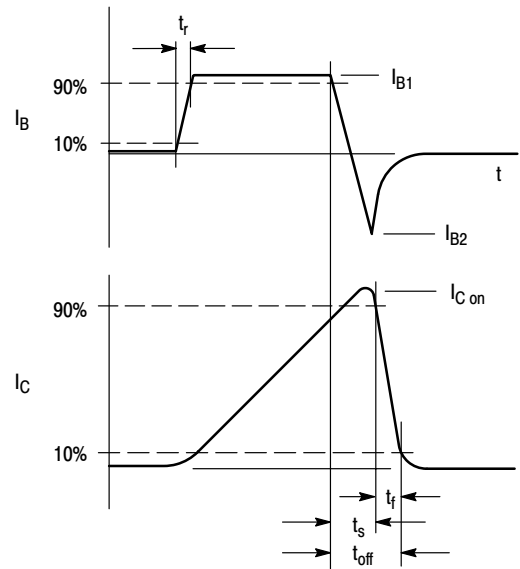

Figure 6. Switching Times Waveforms with Inductive Load

BUT11AF

TEST CONDITIONS FOR ISOLATION TESTS*

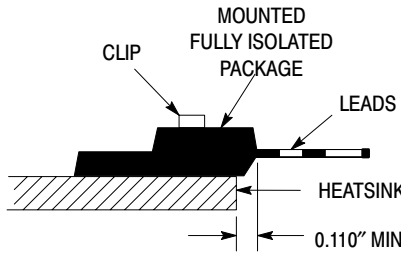

Figure 7. Screw or Clip Mounting Position for Isolation Test Number 1

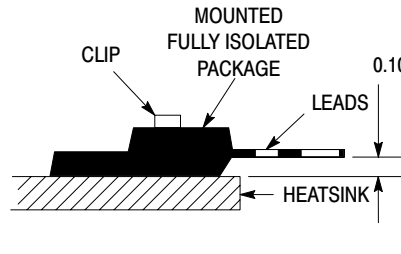

Figure 8. Clip Mounting Position for Isolation Test Number 2

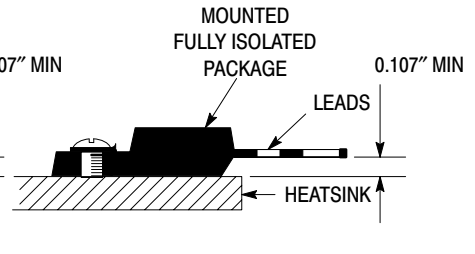

Figure 9. Screw Mounting Position for Isolation Test Number 3

*Measurement made between leads and heatsink with all leads shorted together.

MOUNTING INFORMATION

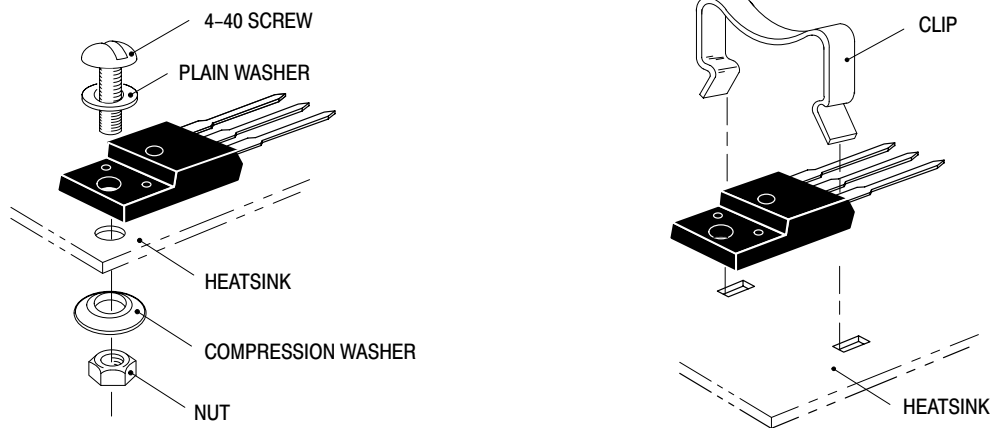

Figure 10. Typical Mounting Techniques for Isolated Package

Laboratory tests on a limited number of samples indicate, when using the screw and compression washer mounting technique, a screw torque of 6 to 8 in · lbs is sufficient to provide maximum power dissipation capability. The compression washer helps to maintain a constant pressure on the package over time and during large temperature excursions.

Destructive laboratory tests show that using a hex head 4–40 screw, without washers, and applying a torque in excess of 20 in · lbs will cause the plastic to crack around the mounting hole, resulting in a loss of isolation capability.

Additional tests on slotted 4–40 screws indicate that the screw slot fails between 15 to 20 in · lbs without adversely affecting the package. However, in order to positively ensure the package integrity of the fully isolated device, ON Semiconductor does not recommend exceeding 10 in · lbs of mounting torque under any mounting conditions.

BUT11AF

PACKAGE DIMENSIONS

TO-220 FULLPAK CASE 221D-02 ISSUE D

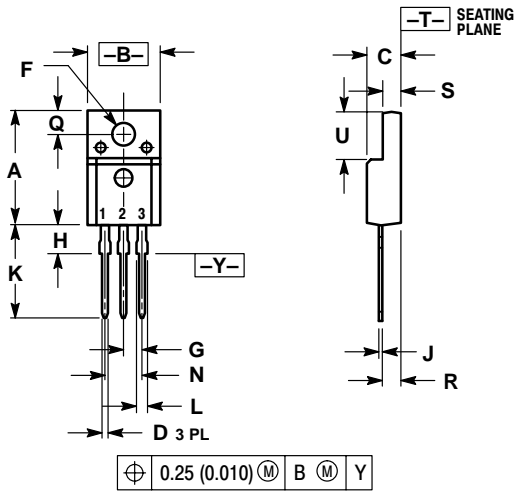

- NOTES:
 1. DIMENSIONING AND TOLERANCING PER ANSI Y14.5M, 1982.
 2. CONTROLLING DIMENSION: INCH.

DIM	INCHES		MILLIMETERS	
	MIN	MAX	MIN	MAX
A	0.621	0.629	15.78	15.97
B	0.394	0.402	10.01	10.21
C	0.181	0.189	4.60	4.80
D	0.026	0.034	0.67	0.86
F	0.121	0.129	3.08	3.27
G	0.100 BSC		2.54 BSC	
H	0.123	0.129	3.13	3.27
J	0.018	0.025	0.46	0.64
K	0.500	0.562	12.70	14.27
L	0.045	0.060	1.14	1.52
N	0.200 BSC		5.08 BSC	
Q	0.126	0.134	3.21	3.40
R	0.107	0.111	2.72	2.81
S	0.096	0.104	2.44	2.64
U	0.259	0.267	6.58	6.78

Notes

Notes

BUT11AF

SWITCHMODE a registered trademark of Semiconductor Components Industries, LLC (SCILLC)

ON Semiconductor and  are trademarks of Semiconductor Components Industries, LLC (SCILLC). SCILLC reserves the right to make changes without further notice to any products herein. SCILLC makes no warranty, representation or guarantee regarding the suitability of its products for any particular purpose, nor does SCILLC assume any liability arising out of the application or use of any product or circuit, and specifically disclaims any and all liability, including without limitation special, consequential or incidental damages. "Typical" parameters which may be provided in SCILLC data sheets and/or specifications can and do vary in different applications and actual performance may vary over time. All operating parameters, including "Typicals" must be validated for each customer application by customer's technical experts. SCILLC does not convey any license under its patent rights nor the rights of others. SCILLC products are not designed, intended, or authorized for use as components in systems intended for surgical implant into the body, or other applications intended to support or sustain life, or for any other application in which the failure of the SCILLC product could create a situation where personal injury or death may occur. Should Buyer purchase or use SCILLC products for any such unintended or unauthorized application, Buyer shall indemnify and hold SCILLC and its officers, employees, subsidiaries, affiliates, and distributors harmless against all claims, costs, damages, and expenses, and reasonable attorney fees arising out of, directly or indirectly, any claim of personal injury or death associated with such unintended or unauthorized use, even if such claim alleges that SCILLC was negligent regarding the design or manufacture of the part. SCILLC is an Equal Opportunity/Affirmative Action Employer.

PUBLICATION ORDERING INFORMATION

NORTH AMERICA Literature Fulfillment:

Literature Distribution Center for ON Semiconductor
P.O. Box 5163, Denver, Colorado 80217 USA
Phone: 303-675-2175 or 800-344-3860 Toll Free USA/Canada
Fax: 303-675-2176 or 800-344-3867 Toll Free USA/Canada
Email: ONlit@hibbertco.com
Fax Response Line: 303-675-2167 or 800-344-3810 Toll Free USA/Canada

N. American Technical Support: 800-282-9855 Toll Free USA/Canada

EUROPE: LDC for ON Semiconductor – European Support

German Phone: (+1) 303-308-7140 (Mon-Fri 2:30pm to 7:00pm CET)
Email: ONlit-german@hibbertco.com
French Phone: (+1) 303-308-7141 (Mon-Fri 2:00pm to 7:00pm CET)
Email: ONlit-french@hibbertco.com
English Phone: (+1) 303-308-7142 (Mon-Fri 12:00pm to 5:00pm GMT)
Email: ONlit@hibbertco.com

EUROPEAN TOLL-FREE ACCESS*: 00-800-4422-3781

*Available from Germany, France, Italy, UK, Ireland

CENTRAL/SOUTH AMERICA:

Spanish Phone: 303-308-7143 (Mon-Fri 8:00am to 5:00pm MST)
Email: ONlit-spanish@hibbertco.com
Toll-Free from Mexico: Dial 01-800-288-2872 for Access –
then Dial 866-297-9322

ASIA/PACIFIC: LDC for ON Semiconductor – Asia Support

Phone: 1-303-675-2121 (Tue-Fri 9:00am to 1:00pm, Hong Kong Time)
Toll Free from Hong Kong & Singapore:
001-800-4422-3781
Email: ONlit-asia@hibbertco.com

JAPAN: ON Semiconductor, Japan Customer Focus Center

4-32-1 Nishi-Gotanda, Shinagawa-ku, Tokyo, Japan 141-0031
Phone: 81-3-5740-2700
Email: r14525@onsemi.com

ON Semiconductor Website: <http://onsemi.com>

For additional information, please contact your local Sales Representative.