

DRAWING MADE IN AMERICAN PROJECTION

©1971 BY AMP INCORPORATED. ALL RIGHTS RESERVED. AMP PRODUCTS COVERED BY PATENTS AND/OR PATENTS PENDING.

THIS PRODUCT DESIGNED AND BUILT BY AMP INCORPORATED. NO LICENSE TO USE THAT DESIGN IN MANUFACTURE, OR TO USE ANY ISSUED OR PENDING PATENTS WHICH ARE INVOLVED, IS IMPLIED.

REVISIONS				
ZONE	LTR	DESCRIPTION	DATE	APPROVED
-	-	WAS SK-33099	1/19/71	<i>NY</i>
	A	ECN L1355.	RPH 4-26-85	<i>m.s.</i>
✓	B	OBS -1, 4, 6, 7, 9, 10 ECN 53630	2-2-87	<i>IM</i>
	C	OBSOLETE -3, 5, -8, 11 ECN L1559	5-27-87	<i>RS</i>

PART NO.	"A"
859355-1	12.00
859355-2	6.00
859355-3	8.00
859355-4	16.00
859355-5	15.00
859355-6	7.00
859355-7	9.00
859355-8	10.00
859355-9	11.00
1-859355-0	13.00
1-859355-1	14.00

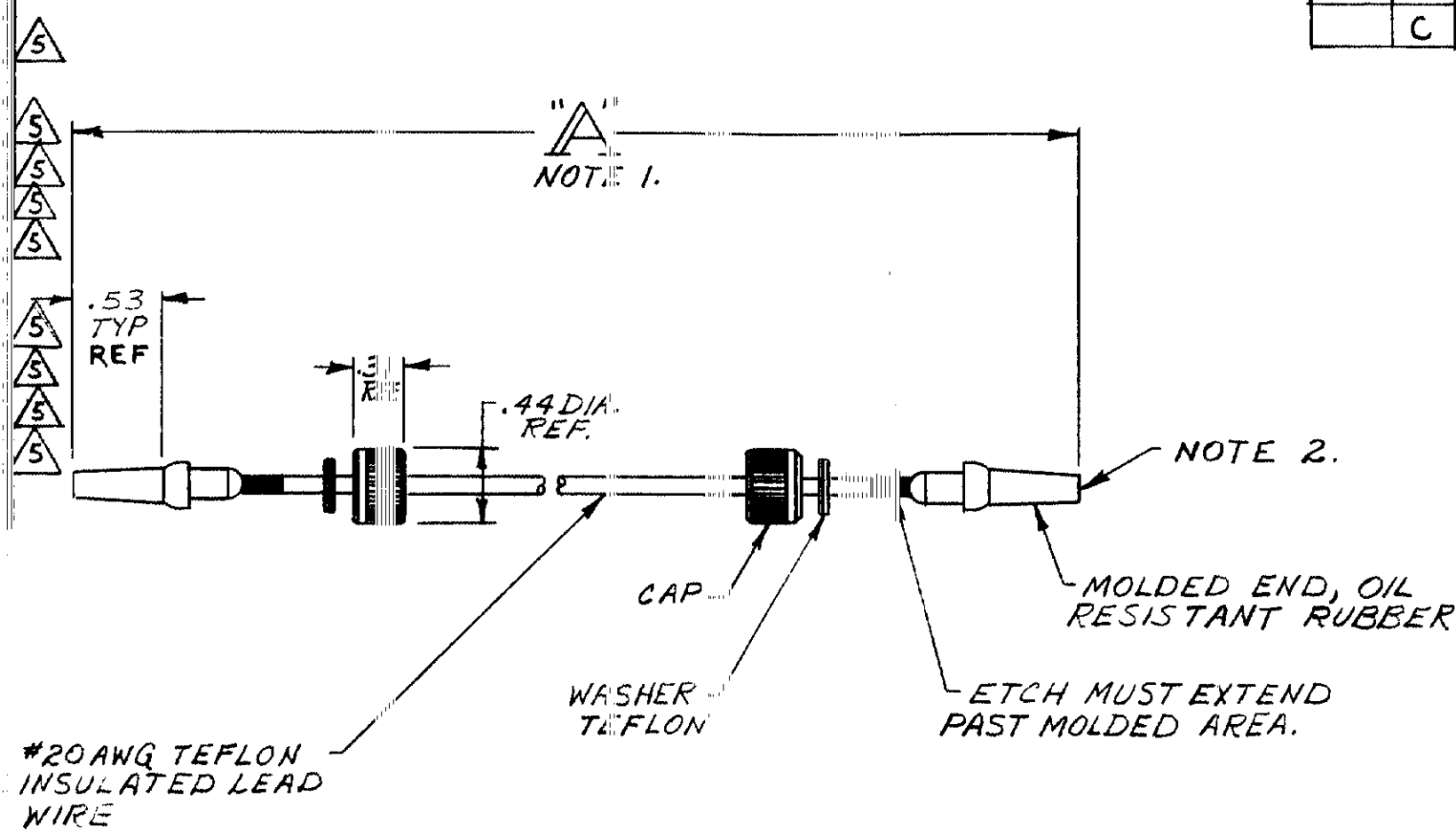

- NOTE:
1. TOLERANCE : UP TO 24" - ± .12  
24" & UP - ± 1%
  2. TO MATE WITH AMP LGH -1/2 RECEPTACLE WITH .53 BARREL DEPTH
  3. MARKED PER MIL-STD-130.
  4. COLOR OF LEAD WIRE WHITE.
- Ⓜ OBSOLETE PART NO.

QTY REQD	QTY REQD	ITEM NO.	DWG SIZE	PART OR IDENTIFYING NO.	NOMENCLATURE OR DESCRIPTION	SYMBOL
-2	-1					
PARTS LIST						
UNLESS OTHERWISE SPECIFIED: DIMENSIONS ARE IN INCHES TOLERANCES .00 ± .04 ANGLES .000 ± .015				CONTRACT NO. DR. <i>1-19-71</i>	 AMP INCORPORATED CAPITRON DIVISION ELIZABETHTOWN, PENNSYLVANIA NAME <b>SPECIAL LGH-1/2 DOUBLE MOLDED ENDS LEAD ASS'Y</b>	
MATERIAL:				CHK APPD. <i>M. Anderson 11/9/71</i> APPD.		
FINISH:				DSGN APPD	SIZE <b>B</b>	CODE IDENT NO. <b>89110</b>
NEXT ASSY				OTHER APPD	NUMBER <b>859355</b>	
QTY REQD	APPLICATION			SCALE <i>N.T.S.</i>	WT	SHEET 1 OF 1

PRINT DIST 2137