

THA-241

アートスリム取手

Flush Pulls



特長

パネル表面に出る部分ができるだけ薄くなるようにデザインされた取手です。他の色調も取り扱っています（特注対応）。

用途

事務机・整理庫の引出し・各種計測機等

注意事項

1. 取付穴はプレスによる打抜き加工とし、ダレ面が表側になるようにしてください。
2. エッジ部にバリがあるような時は、C0.3~C0.5程度の面取りを施してください。
3. 許容荷重は設定しておりませんが、取付穴寸法での取付けの場合、通常使用（人が行う一般的な作業条件において）で脱落することが無いことを確認しております。ご使用される取付条件（取付板の材質、加工法）によっては外れる場合がありますので、実装でご確認いただき、必要であれば接着剤の併用をご検討ください。

Characteristic

Pull with less extrusion on the installed surface.
Other colors are available as custom-made.

Application

Office desks/Closet drawers/Various types of measuring instruments, etc.

Note

1. The hole for installation shall be punched to have shear droop on the front side.
2. When fins are on the edge, C0.3toC0.5 beveling shall be processed.
3. There is no set allowable load, however, it is confirmed not to separate in the ordinary use in the case of installation of installed surface dimension. It might be come off depending on the condition installed such as material of installed board and adding. Please confirm with implementation and consider the use of adhesive if necessary.

材質と処理 Material & Finish

型番 Model No.	材質 Material	処理 Finish
THA-241-□	ABS	黒色 Black
THA-241-□A		アイボリー Ivory
THA-241-□W	AES	白色 White

寸法・仕様表 Size List & Specification

型番 Model No.	A	B	C	D	E	F	G	H	J	K	L	N	色調 Color	自重 (g) Net Weight (g)	価格 (円) Price (yen)												
THA-241-1	100	45	92	28.5	12	95.8	26	4	t0.8	(46)	96.3 ^{+0.2}	40 ^{+0.2}	黒色 Black	22.5	¥80												
THA-241-1-1.2									t1.2						¥85												
THA-241-1-1.6									t1.6						¥85												
THA-241-1A									70				38		61	21	65.5	21	4	t0.8	(38.5)	65.7 ^{+0.1}	32.6 ^{+0.1}	アイボリー Ivory	13	¥90	
THA-241-1A-1.2																				t1.2						¥95	
THA-241-1A-1.6																				t1.6						¥95	
THA-241-1W	100	25	93	17	5	97	3	t0.8	(27.5)	97.2 ^{+0.1}	21.6 ^{+0.1}	黒色 Black	12	¥70													
THA-241-1W-1.2								t1.2						¥130													
THA-241-1W-1.6								t1.6						¥130													
THA-241-2	100	25	93	17	5	97	20	3	t0.8	(27.5)	97.2 ^{+0.1}	21.6 ^{+0.1}		アイボリー Ivory	12	¥70											
THA-241-2-1.2									t1.2							¥70											
THA-241-2-1.6									t1.6							¥70											
THA-241-2A									100				25	93		17	5	97	20	3	t0.8	(27.5)	97.2 ^{+0.1}	21.6 ^{+0.1}	アイボリー Ivory	12	¥70
THA-241-2A-1.2																					t1.2						¥70
THA-241-2A-1.6																					t1.6						¥70
THA-241-2W	100	25	93	17	5	97	20	3	t0.8	(27.5)	97.2 ^{+0.1}	21.6 ^{+0.1}	白色 White	12	¥70												
THA-241-2W-1.2									t1.2						¥95												
THA-241-2W-1.6									t1.6						¥95												
THA-241-3-0.8	100	25	93	17	5	97	20	3	t0.8	(27.5)	97.2 ^{+0.1}	21.6 ^{+0.1}	黒色 Black		12	¥70											
THA-241-3-1.2									t1.2							¥70											
THA-241-3									t1.6							¥70											
THA-241-3A-0.8									100				25	93		17	5	97	20	3	t0.8	(27.5)	97.2 ^{+0.1}	21.6 ^{+0.1}	アイボリー Ivory	12	¥70
THA-241-3A-1.2																					t1.2						¥70
THA-241-3A																					t1.6						¥70
THA-241-3W-0.8	100	25	93	17	5	97	20	3	t0.8	(27.5)	97.2 ^{+0.1}	21.6 ^{+0.1}	白色 White	12	¥70												
THA-241-3W-1.2									t1.2						¥95												
THA-241-3W									t1.6						¥95												

特注品のご相談承ります Please contact us for custom-made.

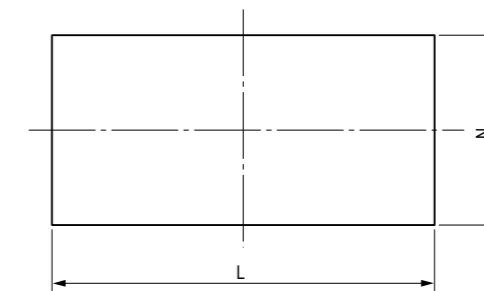
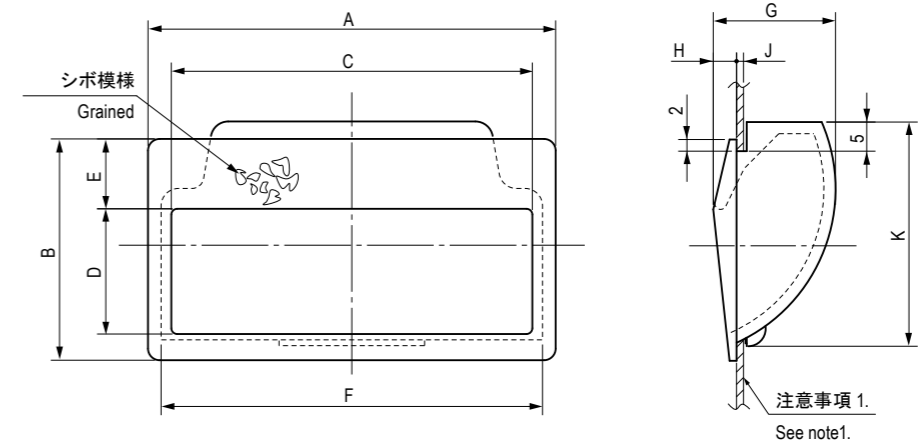

取付穴図
Hole for Installation

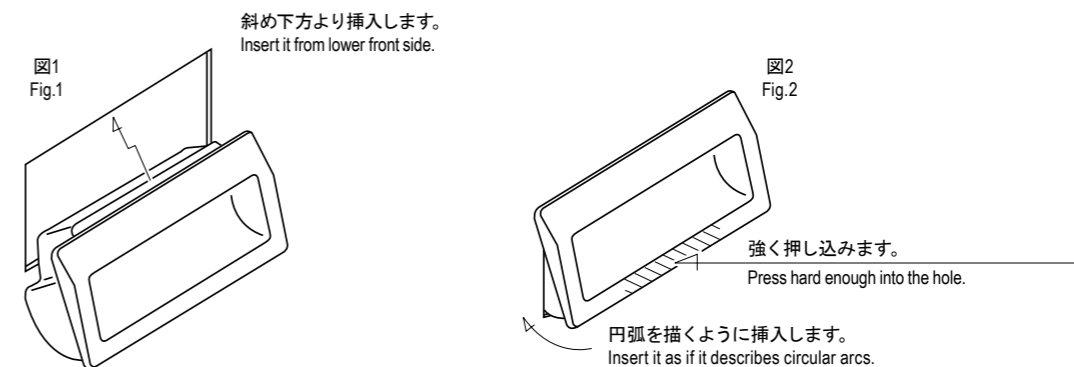

●取付方法

1. 取手を取付穴の斜め下方より挿入し、先の上側の溝にパネルをはめ込みます（図1）。
2. 取手下側の中央部（図2 斜線部）を指で強く押込んでください。

●Installation instruction

1. Insert the pull from lower front side of the panel making the upper slot of pull to fit the upper edge of the panel (Fig. 1).
2. Press lower center side of the pull hard enough into the hole by finger (Fig. 2)

特注品のご相談承ります Please contact us for custom-made.