

# DRV612EVM

This user's guide describes the operation of the DRV612 evaluation module. This document provides design information including a schematic, bill of materials, and printed circuit board (PCB) layout drawings.

## Contents

1	Overview .....	3
1.1	DRV612EVM Features .....	3
2	Quick Setup .....	4
2.1	Electrostatic Discharge Notice .....	4
2.2	Unpacking the EVM .....	4
2.3	Power Supply Setup .....	4
3	Component Selection .....	5
3.1	Charge Pump .....	5
3.2	Power-Supply Decoupling Capacitors .....	5
4	Layout Recommendations .....	5
4.1	PGND and GND Connections .....	5
5	Design Documentation .....	6
5.1	Schematic and PCB Layout .....	6
5.2	Parts List .....	7
5.3	PCB Specification .....	8
5.4	PCB Layers .....	8

## List of Figures

1	DRV612EVM - Top View.....	2
2	DRV612EVM - Bottom View.....	2
3	DRV612EVM Functional Block Diagram.....	3
4	Power-Up/-Down Sequence .....	5
5	DRV612EVM Schematic: DRV612 .....	6
6	DRV612EVM PCB Layout .....	7

## List of Tables

1	Key Parameters .....	4
2	Recommended Supply Voltage .....	4
3	Bill of Materials .....	7
4	PCB Specification.....	8

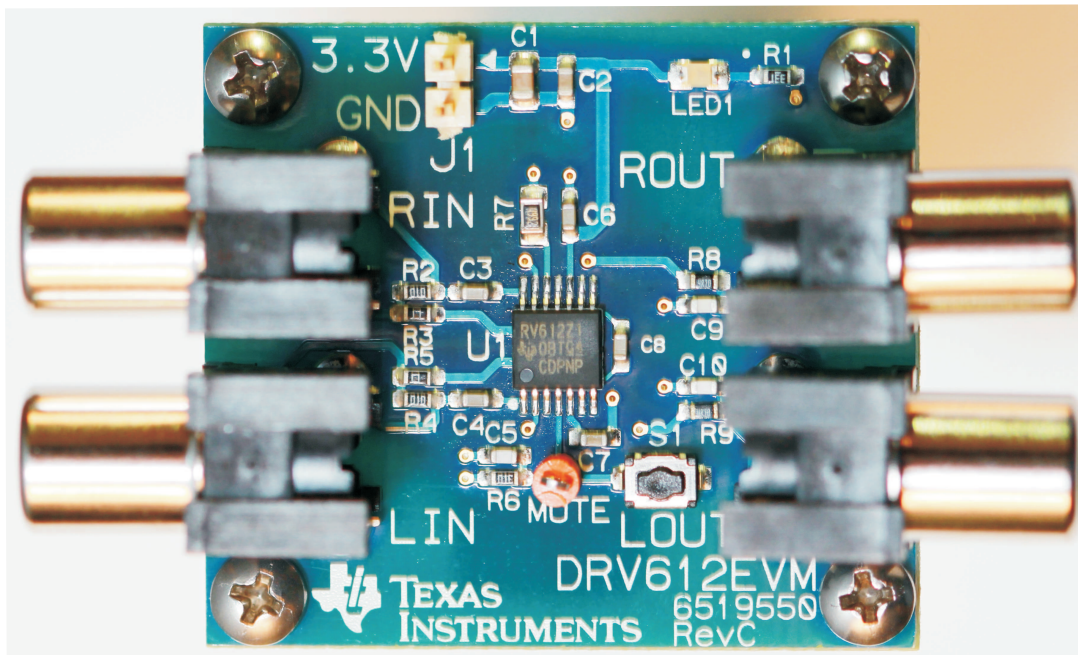

Figure 1. DRV612EVM - Top View

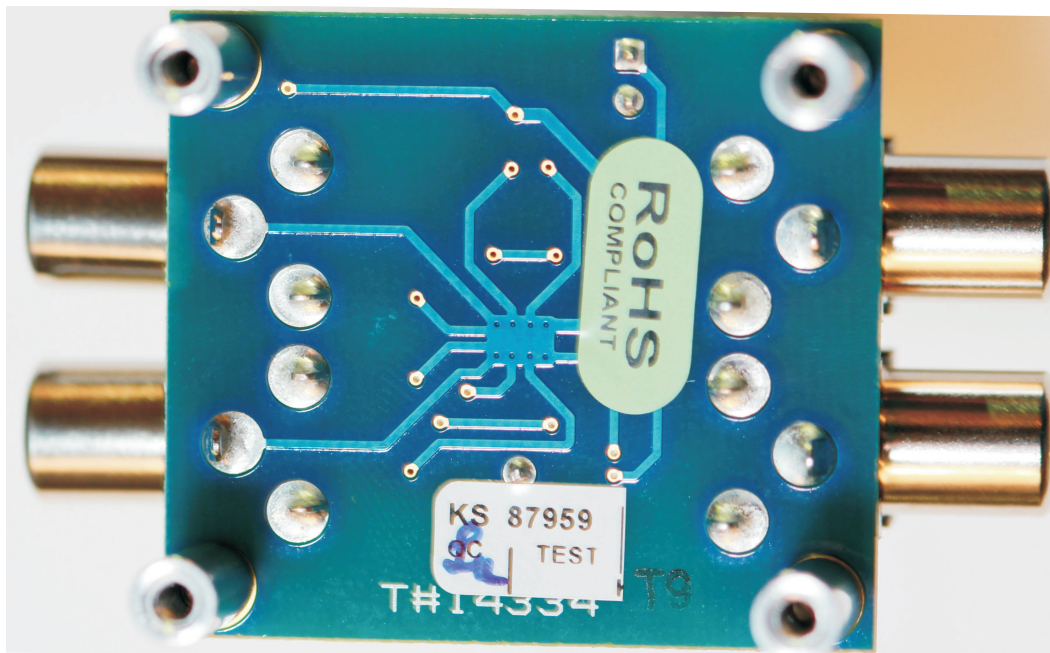

Figure 2. DRV612EVM - Bottom View

## 1 Overview

The DRV612EVM customer evaluation module (EVM) demonstrates the capabilities and operation of the DRV612 integrated circuit from Texas Instruments.

The DRV612 is a 2-VRMS pop-free stereo line driver designed to allow removal of the output dc-blocking capacitors and combined with the internal programmable gain resistors reduce component count and overall cost. The device is ideal for single-supply electronics where size and cost are critical design parameters.

Designed using TI's patented DirectPath™ technology, the DRV612 is capable of driving 2 VRMS into a 600Ω load. The device has fixed-gain single-ended inputs with a gain select pin. Line outputs have ±8kV HBM ESD protection enabling and a simple ESD protection circuit. The DRV612 has built-in active mode control with more than 80 dB attenuation for pop-free mute on/off control.

The DRV612 does not require a power supply greater than 3.3V to generate its 5.6Vpp output, nor does it require a split rail power supply. The DRV612 integrates its own charge pump to generate a negative supply rail that provides a clean, pop-free ground biased 2Vrms output.

The DRV612 is available in a 14-pin TSSOP package.

This EVM is configured with RCA stereo connectors for analog input and stereo output; The power supply is connected via a two-pin, 2.54-mm header.

This evaluation board is designed for testing applications such as set-top boxes, LCD/PDP TVs, Blu-ray Disc™ DVD players, DVD mini-component systems, home theater-in-a-box (HTIB) systems, or soundcards.

---

**NOTE:** This document presents EVM specifications, audio performance measurements graphs, and design documentation that includes complete circuit descriptions, schematic diagrams, a parts list, and PCB layout design. Gerber (layout) files are available from the TI web site at <http://www.ti.com>.

---

Throughout this document, the abbreviation EVM and the term evaluation module are synonymous with the DRV612EVM.

### 1.1 DRV612EVM Features

The DRV612EVM has these features:

- Two-channel evaluation module (double-sided, plated-through PCB layout)
- 2- $V_{RMS}$  stereo line output
- Single-ended analog inputs
- No output capacitor required
- Mute button

Figure 3 illustrates the functional diagram for the EVM. Table 1 summarizes the key parameters.

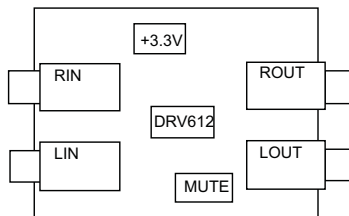

**Figure 3. DRV612EVM Functional Block Diagram**

**Table 1. Key Parameters**

Key Parameters	Specification/Unit
Supply Voltage	3.3 V
Number of channels	Two
Load Impedance	600 $\Omega$
Output Voltage	2 Vrms
Dynamic Range	105 dB

## 2 Quick Setup

This section describes the DRV612EVM board with regards to the power supply and system interfaces. It provides information about handling and unpacking the DRV612EVM, absolute operating conditions, and a description of the factory default configurations.

The following subsections provide a step-by-step guide to configuring the DRV612EVM for device evaluation.

### 2.1 Electrostatic Discharge Notice

#### CAUTION

Many of the components on the DRV612EVM are susceptible to damage by electrostatic discharge (ESD). Customers are advised to observe proper ESD handling precautions when unpacking and handling the EVM, including the use of a grounded wrist strap at an approved ESD workstation. Failure to observe proper ESD handling procedures may result in damage to EVM components.

### 2.2 Unpacking the EVM

Upon opening the DRV612EVM package, ensure that the following items are included:

- One DRV612EVM evaluation board, including:
  - One DRV612PW device

If either item is missing, please contact the Texas Instruments Product Information Center nearest you to inquire about a replacement.

### 2.3 Power Supply Setup

A single power supply is required to power up the EVM. The power supply is connected to the EVM board using a two-pin, 2.54-mm header (J1). [Table 2](#) lists the recommended supply voltage.

**Table 2. Recommended Supply Voltage**

Description	Voltage Limitations	Current Requirement	Cable
Power supply	3.3 V	0.10 A	—

#### CAUTION

Applying voltages above the limitations given in [Table 2](#) may cause permanent damage to your hardware.

### 2.3.1 Pop-Free Power Up

Pop-free power up is ensured by keeping the  $\overline{\text{MUTE}}$  low during power supply ramp up and down. The pins should be kept low until the input AC-coupling capacitors are fully charged before asserting the MUTE pin high, this way proper pre-charge of the ac-coupling is performed and pop-less power-up is achieved.

Figure 4 illustrates the preferred sequence.

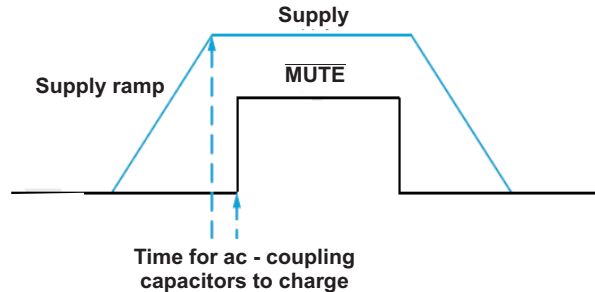

Figure 4. Power-Up/Down Sequence

## 3 Component Selection

### 3.1 Charge Pump

The charge pump flying capacitor, C6, serves to transfer charge during the generation of the negative supply voltage. The PVSS capacitor must be at least equal to the charge pump capacitor in order to allow a maximum charge transfer. Low equivalent series resistance (ESR) capacitors are an ideal selection, with a typical value of 1  $\mu\text{F}$ . Capacitor values less than 1  $\mu\text{F}$  can be used, but the maximum output can be reduced. It is therefore recommended to validate the design with thorough testing.

### 3.2 Power-Supply Decoupling Capacitors

The DRV612 is a DirectPath™ line driver amplifier that requires adequate power-supply decoupling to ensure that noise and total harmonic distortion (THD) are low. A good low ESR ceramic capacitor, C5 (1  $\mu\text{F}$  typical), placed as close as possible to the device P<sub>VDD</sub> leads is the best option. Placing this decoupling capacitor close to the DRV612 device is important for amplifier performance. For filtering lower-frequency noise signals, a 10- $\mu\text{F}$  or greater capacitor placed near the audio amplifier may also help, but is not required in most applications because of the high PSRR of the DRV612.

The charge pump circuit does apply ripple current on the P<sub>VDD</sub> line, and an LC or RC filter may be needed if noise-sensitive audio devices share the P<sub>VDD</sub> supply.

## 4 Layout Recommendations

### 4.1 PGND and GND Connections

The PGND and GND pins of the DRV612 must be routed separately back to the decoupling capacitor in order to facilitate proper device operation.

On the DRV612EVM, a star ground routing pattern is used; the star point is located directly below the DRV612 device itself.

5 Design Documentation

5.1 Schematic and PCB Layout

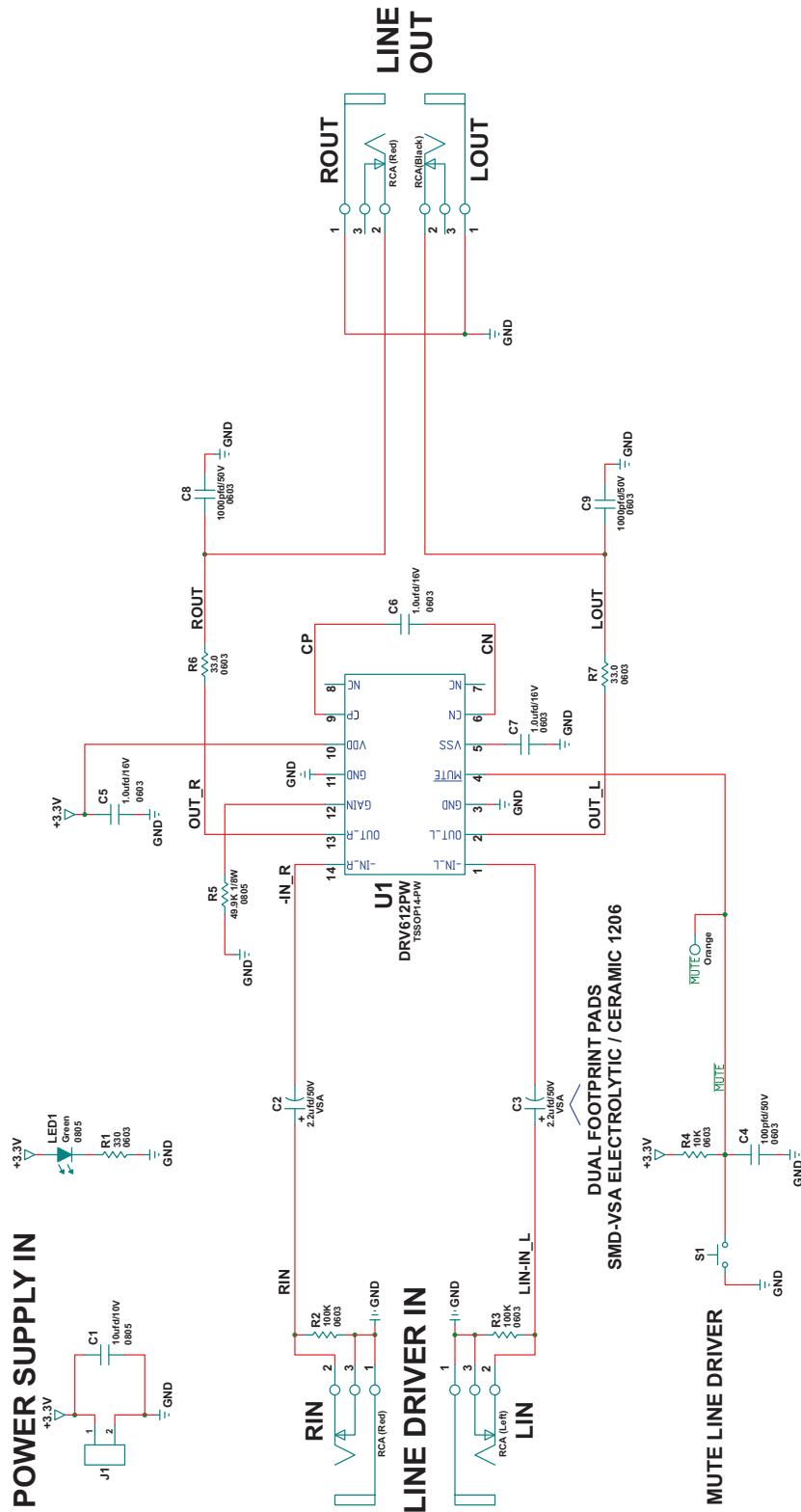
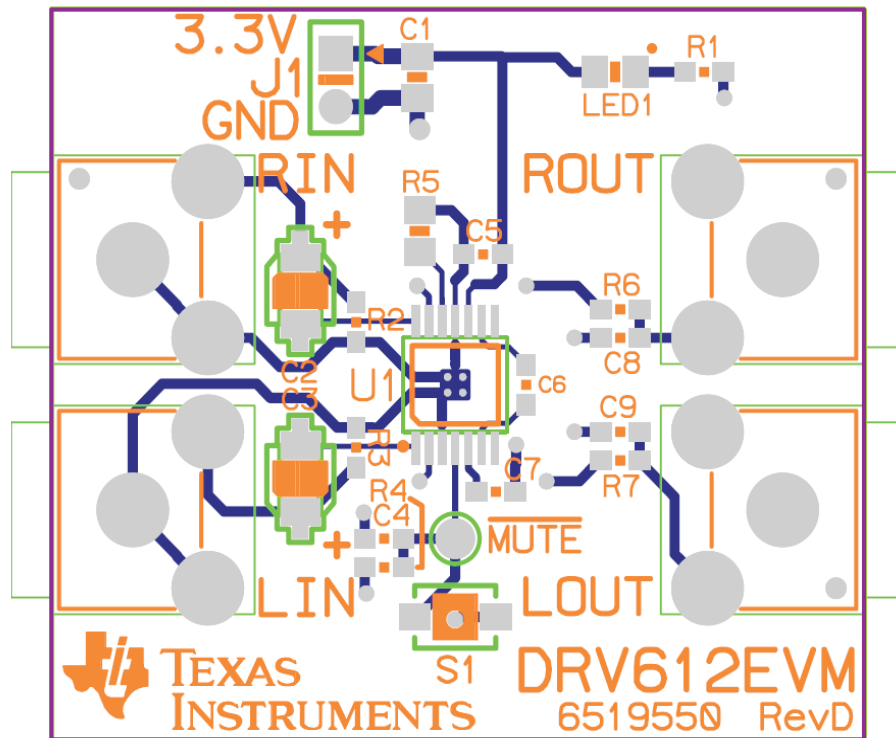

Figure 5. DRV612EV M Schematic: DRV612

**Figure 6. DRV612EVM PCB Layout**

## 5.2 Parts List

The bill of materials (BOM) for the DRV612EVM is listed in [Table 3](#).

**Table 3. Bill of Materials**

Qty	Part Reference	Description	Manufacturer	Mfr Part No
1	U1	DIRECTPATH 2V LINE DRIVER/ FIXED GAIN 14-pin HTSSOP PW ROHS	TEXAS INSTRUMENTS	DRV612PW
1	LED1	LED, GREEN 2.0V SMD0805 ROHS	LUMEX OPTO	SML-LXT0805GW-TR
2	C8, C9	CAP SMD0603 CERM 1000PFD 50V 5% COG ROHS	TDK CORP.	C1608C0G1H102J
1	C4	CAP SMD0603 CERM 100PFD 50V 5% COG ROHS	MURATA	GRM1885C1H101JA01D
2	C2, C3	CAP ALUM-ELECT SMD-VSA 2.2UF 50V 20% ROHS	PANASONIC	EEE-1HS2R2SR
3	C5, C6, C7	CAP SMD0603 CERM 1.0UF 16V 10% X7R ROHS	TDK	C1608X7R1C105K
1	C1	CAP SMD0805 CERM 10UF 10V10% X7R ROHS	MURATA	GRM21BR71A106KE51L
2	R6, R7	RESISTOR SMD0603 33.0 OHMS 1% 1/10W ROHS	PANASONIC	ERJ-3EKF33R0
1	R1	RESISTOR SMD0603 330 OHMS 5% 1/10W ROHS	PANASONIC	ERJ-3GEYJ331V
1	R4	RESISTOR SMD0603 10K 5% 1/10W ROHS	PANASONIC	ERJ-3GEYJ103V
1	R5	RESISTOR SMD0805 49.9K OHMS 1% 1/8W THICK FILM ROHS	VISHAY	CRCW080549K9FKEA
2	R2, R3	RESISTOR SMD0603 100K OHM 5% THICK FILM 1/10W ROHS	PANASONIC	CRCW06031K02FKTA-ND
1	J1	HEADER THRU MALE 2 PIN 100LS GOLD ROHS	SULLINS	PBC02SAAN
2	LIN, LOUT	JACK, RCA 3-PIN PCB-RA BLACK ROHS	SWITCHCRAFT	PJRAN1X1U01X
2	RIN, ROUT	JACK, RCA 3-PIN PCB-RA RED ROHS	SWITCHCRAFT	PJRAN1X1U03X
1	MUTE	PC TESTPOINT, ORANGE, ROHS	KEYSTONE ELECTRONICS	5003
1	S1	SWITCH, MOM, 160G SMT 4X3MM ROHS	E-SWITCH	TL1015AF160QG
4	NA	STANDOFF, 4-40, 0.5INx3/16IN, ALUM RND F-F	KEYSTONE ELECTRONICS	2027
4	NA	4-40 SCREW, STEEL 0.250 IN	BUILDING FASTENERS	PMS 440 0025 PH

### 5.3 PCB Specification

Table 4 summarizes the specifications for the evaluation board PCB.

**Table 4. PCB Specification**

Board Identification	A852-PCB-001 (2.00)
Board type	Double-sided plated-through board
Laminate type	FR4
Laminate thickness	1,0 mm
Copper thickness	35 µm (including plating exterior layers)
Copper plating of holes	>25 µm
Minimum hole diameter	0.3 mm
Silkscreen, component side	White; remove silkscreen from solder and pre-tinned areas
Silkscreen, component side	None
Soldermask, component side	Green
Soldermask, solder side	Green
Protective coating	Solder coating and chemical silver on free copper
Electrical test	PCB must be electrically tested
Manufactured to	PERFAG 2E ( <a href="http://www.perfag.dk">http://www.perfag.dk</a> )
Aperture table	PERFAG 10A ( <a href="http://www.perfag.dk">http://www.perfag.dk</a> )
Board dimensions	60 mm × 90 mm

### 5.4 PCB Layers

Gerber files are available for download at the DRV612EVM product folder page on the TI web site. Component placement and board layout are illustrated in Figure 6.

---

**NOTE:** Board layouts are not to scale. These figures are intended to show how the board is laid out; they are not intended to be used for manufacturing DRV612EVM PCBs.

---



## Evaluation Board/Kit Important Notice

Texas Instruments (TI) provides the enclosed product(s) under the following conditions:

This evaluation board/kit is intended for use for **ENGINEERING DEVELOPMENT, DEMONSTRATION, OR EVALUATION PURPOSES ONLY** and is not considered by TI to be a finished end-product fit for general consumer use. Persons handling the product(s) must have electronics training and observe good engineering practice standards. As such, the goods being provided are not intended to be complete in terms of required design-, marketing-, and/or manufacturing-related protective considerations, including product safety and environmental measures typically found in end products that incorporate such semiconductor components or circuit boards. This evaluation board/kit does not fall within the scope of the European Union directives regarding electromagnetic compatibility, restricted substances (RoHS), recycling (WEEE), FCC, CE or UL, and therefore may not meet the technical requirements of these directives or other related directives.

Should this evaluation board/kit not meet the specifications indicated in the User's Guide, the board/kit may be returned within 30 days from the date of delivery for a full refund. **THE FOREGOING WARRANTY IS THE EXCLUSIVE WARRANTY MADE BY SELLER TO BUYER AND IS IN LIEU OF ALL OTHER WARRANTIES, EXPRESSED, IMPLIED, OR STATUTORY, INCLUDING ANY WARRANTY OF MERCHANTABILITY OR FITNESS FOR ANY PARTICULAR PURPOSE.**

The user assumes all responsibility and liability for proper and safe handling of the goods. Further, the user indemnifies TI from all claims arising from the handling or use of the goods. Due to the open construction of the product, it is the user's responsibility to take any and all appropriate precautions with regard to electrostatic discharge.

**EXCEPT TO THE EXTENT OF THE INDEMNITY SET FORTH ABOVE, NEITHER PARTY SHALL BE LIABLE TO THE OTHER FOR ANY INDIRECT, SPECIAL, INCIDENTAL, OR CONSEQUENTIAL DAMAGES.**

TI currently deals with a variety of customers for products, and therefore our arrangement with the user **is not exclusive.**

TI assumes **no liability for applications assistance, customer product design, software performance, or infringement of patents or services described herein.**

Please read the User's Guide and, specifically, the Warnings and Restrictions notice in the User's Guide prior to handling the product. This notice contains important safety information about temperatures and voltages. For additional information on TI's environmental and/or safety programs, please contact the TI application engineer or visit [www.ti.com/esh](http://www.ti.com/esh).

No license is granted under any patent right or other intellectual property right of TI covering or relating to any machine, process, or combination in which such TI products or services might be or are used.

## FCC Warning

This evaluation board/kit is intended for use for **ENGINEERING DEVELOPMENT, DEMONSTRATION, OR EVALUATION PURPOSES ONLY** and is not considered by TI to be a finished end-product fit for general consumer use. It generates, uses, and can radiate radio frequency energy and has not been tested for compliance with the limits of computing devices pursuant to part 15 of FCC rules, which are designed to provide reasonable protection against radio frequency interference. Operation of this equipment in other environments may cause interference with radio communications, in which case the user at his own expense will be required to take whatever measures may be required to correct this interference.

## EVM Warnings and Restrictions

It is important to operate this EVM within the input voltage range of 0 V to 3 V and the output voltage range of 0 V to 3.3 V .

Exceeding the specified input range may cause unexpected operation and/or irreversible damage to the EVM. If there are questions concerning the input range, please contact a TI field representative prior to connecting the input power.

Applying loads outside of the specified output range may result in unintended operation and/or possible permanent damage to the EVM. Please consult the EVM User's Guide prior to connecting any load to the EVM output. If there is uncertainty as to the load specification, please contact a TI field representative.

During normal operation, some circuit components may have case temperatures greater than 60°C. The EVM is designed to operate properly with certain components above 40°C as long as the input and output ranges are maintained. These components include but are not limited to linear regulators, switching transistors, pass transistors, and current sense resistors. These types of devices can be identified using the EVM schematic located in the EVM User's Guide. When placing measurement probes near these devices during operation, please be aware that these devices may be very warm to the touch.

Mailing Address: Texas Instruments, Post Office Box 655303, Dallas, Texas 75265  
Copyright © 2011, Texas Instruments Incorporated

## IMPORTANT NOTICE

Texas Instruments Incorporated and its subsidiaries (TI) reserve the right to make corrections, modifications, enhancements, improvements, and other changes to its products and services at any time and to discontinue any product or service without notice. Customers should obtain the latest relevant information before placing orders and should verify that such information is current and complete. All products are sold subject to TI's terms and conditions of sale supplied at the time of order acknowledgment.

TI warrants performance of its hardware products to the specifications applicable at the time of sale in accordance with TI's standard warranty. Testing and other quality control techniques are used to the extent TI deems necessary to support this warranty. Except where mandated by government requirements, testing of all parameters of each product is not necessarily performed.

TI assumes no liability for applications assistance or customer product design. Customers are responsible for their products and applications using TI components. To minimize the risks associated with customer products and applications, customers should provide adequate design and operating safeguards.

TI does not warrant or represent that any license, either express or implied, is granted under any TI patent right, copyright, mask work right, or other TI intellectual property right relating to any combination, machine, or process in which TI products or services are used. Information published by TI regarding third-party products or services does not constitute a license from TI to use such products or services or a warranty or endorsement thereof. Use of such information may require a license from a third party under the patents or other intellectual property of the third party, or a license from TI under the patents or other intellectual property of TI.

Reproduction of TI information in TI data books or data sheets is permissible only if reproduction is without alteration and is accompanied by all associated warranties, conditions, limitations, and notices. Reproduction of this information with alteration is an unfair and deceptive business practice. TI is not responsible or liable for such altered documentation. Information of third parties may be subject to additional restrictions.

Resale of TI products or services with statements different from or beyond the parameters stated by TI for that product or service voids all express and any implied warranties for the associated TI product or service and is an unfair and deceptive business practice. TI is not responsible or liable for any such statements.

TI products are not authorized for use in safety-critical applications (such as life support) where a failure of the TI product would reasonably be expected to cause severe personal injury or death, unless officers of the parties have executed an agreement specifically governing such use. Buyers represent that they have all necessary expertise in the safety and regulatory ramifications of their applications, and acknowledge and agree that they are solely responsible for all legal, regulatory and safety-related requirements concerning their products and any use of TI products in such safety-critical applications, notwithstanding any applications-related information or support that may be provided by TI. Further, Buyers must fully indemnify TI and its representatives against any damages arising out of the use of TI products in such safety-critical applications.

TI products are neither designed nor intended for use in military/aerospace applications or environments unless the TI products are specifically designated by TI as military-grade or "enhanced plastic." Only products designated by TI as military-grade meet military specifications. Buyers acknowledge and agree that any such use of TI products which TI has not designated as military-grade is solely at the Buyer's risk, and that they are solely responsible for compliance with all legal and regulatory requirements in connection with such use.

TI products are neither designed nor intended for use in automotive applications or environments unless the specific TI products are designated by TI as compliant with ISO/TS 16949 requirements. Buyers acknowledge and agree that, if they use any non-designated products in automotive applications, TI will not be responsible for any failure to meet such requirements.

Following are URLs where you can obtain information on other Texas Instruments products and application solutions:

### Products

Audio	<a href="http://www.ti.com/audio">www.ti.com/audio</a>
Amplifiers	<a href="http://amplifier.ti.com">amplifier.ti.com</a>
Data Converters	<a href="http://dataconverter.ti.com">dataconverter.ti.com</a>
DLP® Products	<a href="http://www.dlp.com">www.dlp.com</a>
DSP	<a href="http://dsp.ti.com">dsp.ti.com</a>
Clocks and Timers	<a href="http://www.ti.com/clocks">www.ti.com/clocks</a>
Interface	<a href="http://interface.ti.com">interface.ti.com</a>
Logic	<a href="http://logic.ti.com">logic.ti.com</a>
Power Mgmt	<a href="http://power.ti.com">power.ti.com</a>
Microcontrollers	<a href="http://microcontroller.ti.com">microcontroller.ti.com</a>
RFID	<a href="http://www.ti-rfid.com">www.ti-rfid.com</a>
RF/IF and ZigBee® Solutions	<a href="http://www.ti.com/lprf">www.ti.com/lprf</a>

### Applications

Communications and Telecom	<a href="http://www.ti.com/communications">www.ti.com/communications</a>
Computers and Peripherals	<a href="http://www.ti.com/computers">www.ti.com/computers</a>
Consumer Electronics	<a href="http://www.ti.com/consumer-apps">www.ti.com/consumer-apps</a>
Energy and Lighting	<a href="http://www.ti.com/energy">www.ti.com/energy</a>
Industrial	<a href="http://www.ti.com/industrial">www.ti.com/industrial</a>
Medical	<a href="http://www.ti.com/medical">www.ti.com/medical</a>
Security	<a href="http://www.ti.com/security">www.ti.com/security</a>
Space, Avionics and Defense	<a href="http://www.ti.com/space-avionics-defense">www.ti.com/space-avionics-defense</a>
Transportation and Automotive	<a href="http://www.ti.com/automotive">www.ti.com/automotive</a>
Video and Imaging	<a href="http://www.ti.com/video">www.ti.com/video</a>
Wireless	<a href="http://www.ti.com/wireless-apps">www.ti.com/wireless-apps</a>

TI E2E Community Home Page

[e2e.ti.com](http://e2e.ti.com)

Mailing Address: Texas Instruments, Post Office Box 655303, Dallas, Texas 75265  
Copyright © 2011, Texas Instruments Incorporated