

# 30mm (1.2 ") 5x7 DOT MATRIX DISPLAY



# SUN LED

Email : sales@us.sunled.com

Web Site : www.sunled.com

XMURG30A-1B

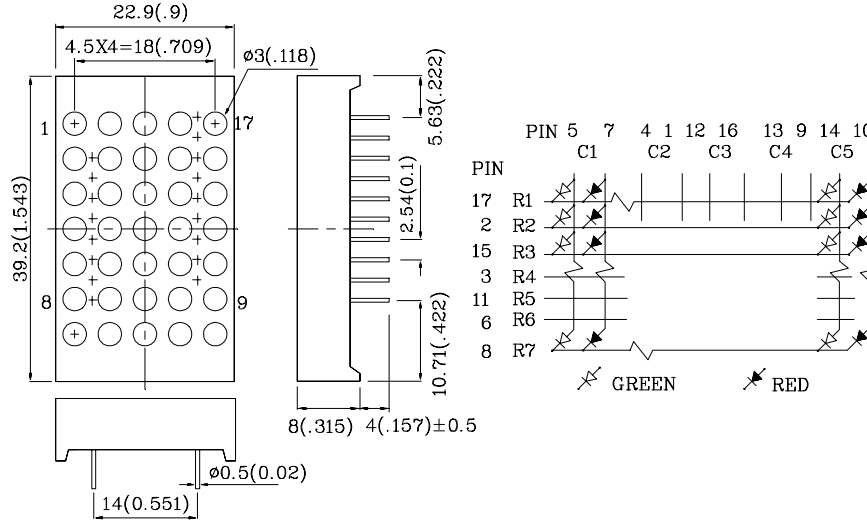

**Notes:**

1. All dimensions are in millimeters (inches).
2. Tolerance is ±0.25(0.01") unless otherwise noted.

Absolute maximum ratings (T <sub>A</sub> =25°C)		UR (GaAsP/GaP)	UG (GaP)	Unit
Reverse voltage	V <sub>R</sub>	5	5	V
Forward current	I <sub>F</sub>	30	25	mA
Forward current (peak) 1/10Duty cycle 0.1ms pulse width	i <sub>FS</sub>	160	140	mA
Power dissipation	P <sub>T</sub>	105	105	mW
Operating temperature	T <sub>A</sub>	-40 ~ +85	-40 ~ +85	°C
Storage temperature	T <sub>stg</sub>	-40 ~ +85	-40 ~ +85	
Lead solder temperature [2mm below package base]	260°C For 5 Seconds			

Operating Characteristics (T <sub>A</sub> =25°C)		UR (GaAsP/GaP)	UG (GaP)	Unit
Forward voltage (typ.) (I <sub>F</sub> =10mA)	V <sub>F</sub>	1.9	2.0	V
Forward voltage (max.) (I <sub>F</sub> =10mA)	V <sub>F</sub>	2.5	2.5	V
Reverse current (V <sub>R</sub> =5V)	I <sub>R</sub>	10	10	uA
Wavelength at peak emission (I <sub>F</sub> =10mA)	λ <sub>peak</sub>	627	565	nm
Wavelength at Dominate emission (I <sub>F</sub> =10mA)	λ <sub>D</sub>	625	568	nm
Spectral Line half-width (I <sub>F</sub> =10mA)	Δλ	45	30	nm
Capacitance (V <sub>F</sub> =0V, f=1MHz)	C	15	15	pF

Part Number	Emitting Color	Emitting Material	Luminous Intensity (I <sub>F</sub> =10mA) ucd		Wavelength nm λ <sub>P</sub>	Description
			min.	typ.		
XMURG30A-1B	Red	GaAsP/GaP	3000	7990	627	Column Anode
	Green	GaP	3000	10490	565	

**XMURG30A-1B**

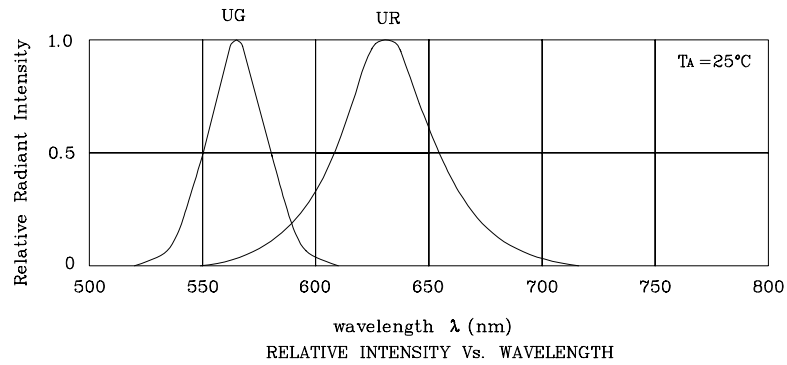

**◆UR**

