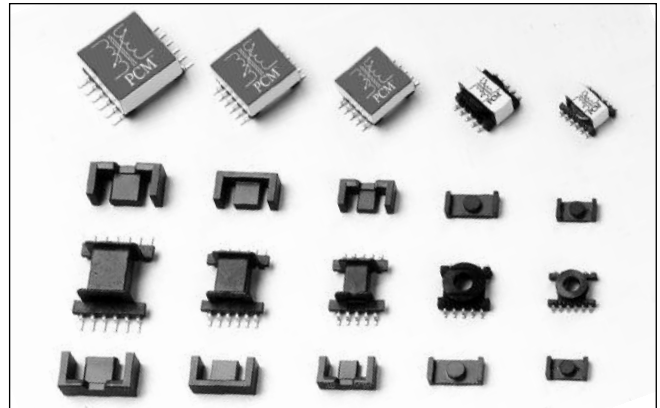

Description

- Six winding, surface mount devices that offer more than 500 usable inductor or transformer configurations
- High power density and low profile
- Low radiated noise and tightly coupled windings
- Power range from 1 Watt – 70 Watts
- Frequency range to over 1MHz
- 500 VAC Isolation
- Ferrite core material

Applications

- Inductors: buck, boost, coupled, choke, filter, resonant, noise filtering, differential, forward, common mode
- Transformers: flyback, feed forward, push-pull, multiple output, inverter, step-up, step-down, gate drive, base drive, wide band, pulse, control, impedance, isolation, bridging, ringer, converter, auto

Environmental Data

- Storage temperature range: -55°C to 125°C
- Operating ambient temperature range: -40°C to +85°C (range is application specific). The internal “hot spot” temperature defines the maximum allowable currents, which are limited to 130°C, including ambient
- Solder reflow temperature: +260°C max for 10 seconds max.

Packaging

- Supplied in tape and reel packaging, 600 (VP01), 300 (VP02), and 200 (VP03) per reel
- Supplied in bulk packaging (VP04 and VP05)
- VP04 & VP05 tape and reel packaging available. Please contact factory for details.

Part ⁽¹⁾ Number	L(BASE) μH (NOM) ⁽²⁾	ISAT(BASE) Amps (TYP) ⁽³⁾⁽⁴⁾	IRMS(BASE) Amps (TYP) ⁽³⁾⁽⁵⁾	R(BASE) Ohms (MAX) ⁽⁶⁾	Volt-μSEC(BASE) μVs (MAX) ⁽⁷⁾	EPEAK(BASE) μJ (TYP) ⁽⁸⁾	Leakage Inductance (BASE) μH (TYP)	Thermal Resistance °C/Watt (TYP) ⁽⁹⁾
VPH1-1400-R ⁽¹⁰⁾	201.6 +/-30%	0.04	0.55	0.344	32.9	0.11	0.212	60.7
VP1-1400-R ⁽¹⁰⁾	89.6 +/-30%	0.06	0.85	0.145	21.8	0.11	0.096	60.7
VPH1-0190-R	27.4 +/-20%	0.29	0.55	0.344	32.9	0.77	0.212	60.7
VP1-0190-R	12.2 +/-20%	0.43	0.85	0.145	21.8	0.77	0.096	60.7
VPH1-0102-R	14.7 +/-20%	0.53	0.55	0.344	32.9	1.45	0.212	60.7
VP1-0102-R	6.5 +/-20%	0.80	0.85	0.145	21.8	1.45	0.096	60.7
VPH1-0076-R	10.9 +/-20%	0.72	0.55	0.344	32.9	1.92	0.212	60.7
VP1-0076-R	4.9 +/-20%	1.06	0.85	0.145	21.8	1.92	0.096	60.7
VPH1-0059-R	8.5 +/-20%	0.92	0.55	0.344	32.9	2.48	0.212	60.7
VP1-0059-R	3.8 +/-20%	1.37	0.85	0.145	21.8	2.48	0.096	60.7
VPH2-1600-R ⁽¹⁰⁾	160 +/-30%	0.07	0.95	0.159	48.3	0.29	0.165	44.0
VP2-1600-R ⁽¹⁰⁾	78.4 +/-30%	0.10	1.26	0.090	33.7	0.29	0.083	44.0
VPH2-0216-R	21.6 +/-20%	0.53	0.95	0.159	48.3	2.11	0.165	44.0
VP2-0216-R	10.6 +/-20%	0.76	1.26	0.090	33.7	2.11	0.083	44.0
VPH2-0116-R	11.6 +/-20%	0.99	0.95	0.159	48.3	3.94	0.165	44.0
VP2-0116-R	5.7 +/-20%	1.41	1.26	0.090	33.7	3.94	0.083	44.0
VPH2-0083-R	8.3 +/-20%	1.39	0.95	0.159	48.3	5.47	0.165	44.0
VP2-0083-R	4.1 +/-20%	1.95	1.26	0.090	33.7	5.47	0.083	44.0
VPH2-0066-R	6.6 +/-20%	1.74	0.95	0.159	48.3	7.01	0.165	44.0
VP2-0066-R	3.2 +/-20%	2.50	1.26	0.090	33.7	7.01	0.083	44.0
VPH3-0780-R ⁽¹⁰⁾	132 +/-30%	0.07	0.97	0.14	39.8	0.24	0.125	43.4
VP3-0780-R ⁽¹⁰⁾	63.2 +/-30%	0.10	1.47	0.061	27.7	0.24	0.058	43.4
VPH3-0138-R	23.3 +/-20%	0.41	0.97	0.14	39.8	1.36	0.125	43.4
VP3-0138-R	11.2 +/-20%	0.59	1.47	0.061	27.7	1.36	0.058	43.4
VPH3-0084-R	14.2 +/-20%	0.67	0.97	0.14	39.8	2.23	0.125	43.4
VP3-0084-R	6.8 +/-20%	0.97	1.47	0.061	27.7	2.23	0.058	43.4
VPH3-0055-R	9.3 +/-20%	1.02	0.97	0.14	39.8	3.38	0.125	43.4
VP3-0055-R	4.5 +/-20%	1.46	1.47	0.061	27.7	3.38	0.058	43.4
VPH3-0047-R	7.94 +/-20%	1.19	0.97	0.14	39.8	4.00	0.125	43.4
VP3-0047-R	3.8 +/-20%	1.73	1.47	0.061	27.7	4.00	0.058	43.4

Part ⁽¹⁾ Number	L(BASE) μH (NOM) ⁽²⁾	ISAT(BASE) Amps (TYP) ⁽³⁾⁽⁴⁾	IRMS(BASE) Amps (TYP) ⁽³⁾⁽⁵⁾	R(BASE) Ohms (MAX) ⁽⁶⁾	Volt-μSEC(BASE) μVs (MAX) ⁽⁷⁾	EPEAK(BASE) μJ (TYP) ⁽⁸⁾	Leakage Inductance (BASE) μH (TYP)	Thermal Resistance °C/Watt (TYP) ⁽⁹⁾
VPH4-0860-R ⁽¹⁰⁾	159.65 +/-30%	0.11	1.41	0.0828	64.6	0.57	0.156	39.4
VP4-0860-R ⁽¹⁰⁾	87.0 +/-30%	0.15	1.70	0.057	44.7	0.57	0.075	39.4
VPH4-0140-R	23.7 +/-20%	0.65	1.41	0.0828	64.6	3.54	0.156	39.4
VP4-0140-R	11.3 +/-20%	0.95	1.70	0.057	44.7	3.54	0.075	39.4
VPH4-0075-R	12.7 +/-20%	1.21	1.41	0.0828	64.6	6.55	0.156	39.4
VP4-0075-R	6.1 +/-20%	1.75	1.70	0.057	44.7	6.55	0.075	39.4
VPH4-0060-R	10.1 +/-20%	1.52	1.41	0.0828	64.6	8.16	0.156	39.4
VP4-0060-R	4.9 +/-20%	2.18	1.70	0.057	44.7	8.16	0.075	39.4
VPH4-0047-R	7.94 +/-20%	1.94	1.41	0.0828	64.6	10.52	0.156	39.4
VP4-0047-R	3.8 +/-20%	2.81	1.70	0.057	44.7	10.52	0.075	39.4
VPH5-1200-R ⁽¹⁰⁾	173 +/-30%	0.14	1.70	0.0711	98.4	1.11	0.235	30.3
VP5-1200-R ⁽¹⁰⁾	76.8 +/-30%	0.20	2.08	0.047	65.6	1.11	0.105	30.3
VPH5-0155-R	22.3 +/-20%	1.05	1.70	0.0711	98.4	8.83	0.235	30.3
VP5-0155-R	9.9 +/-20%	1.60	2.08	0.047	65.6	8.83	0.105	30.3
VPH5-0083-R	12 +/-20%	1.96	1.70	0.0711	98.4	16.07	0.235	30.3
VP5-0083-R	5.3 +/-20%	2.95	2.08	0.047	65.6	16.07	0.105	30.3
VPH5-0067-R	9.65 +/-20%	2.43	1.70	0.0711	98.4	19.83	0.235	30.3
VP5-0067-R	4.3 +/-20%	3.63	2.08	0.047	65.6	19.83	0.105	30.3
VPH5-0053-R	7.63 +/-20%	3.07	1.70	0.0711	98.4	25.10	0.235	30.3
VP5-0053-R	3.4 +/-20%	4.59	2.08	0.047	65.6	25.10	0.105	30.3

(1) The first three digits in the part number signify the size of the package. The next four digits specify the AL, or nanoHenries per turn squared.

(2) L_{BASE} = Nominal Inductance of a single winding.

(3) I_{SAT} is the lessor of I_{SAT(BASE)} and I_{IRMS(BASE)}.

(4) Peak current that will result in 30% saturation of the core. This current value assumes that equal current flows in all six windings. For applications in which all windings are not simultaneously driven (i.e. flyback, SEPIC, Cuk, etc.), the saturation current per winding may be calculated as follows:

$$I_{SAT} = \frac{6 \times I_{SAT(BASE)}}{\text{Number of Windings Driven}}$$

(5) RMS Current that results in a surface temperature of approximately 40°C above ambient. The 40°C rise occurs when the specified current flows through each of the six windings.

(6) Maximum DC Resistance of each winding.

(7) For multiple windings in series, the volt-μsecond_{TOTAL} (μVs) capability varies as the number of windings in series (S):

$$\text{Volt-}\mu\text{sec}_{TOTAL} = S \times \text{Volt-}\mu\text{sec}_{(BASE)}$$

For multiple windings in parallel, the volt-μsecond_{TOTAL} (μVs) capability is as shown in the table above.

(8) Maximum Energy capability of each winding. This is based on 30% saturation of the core:

$$\text{Energy}_{SERIES} = S^2 \times \frac{1}{2} \times 0.7L_{BASE} \times I_{SAT(BASE)}^2$$

$$\text{Energy}_{PARALLEL} = P^2 \times \frac{1}{2} \times 0.7L_{BASE} \times I_{SAT(BASE)}^2$$

For multiple windings, the energy capability varies as the square of the number of windings. For example, six windings (either parallel or series) can store 36 times more energy than one winding.

(9) Thermal Resistance is the approximate surface temperature rise per Watt of heat loss under still-air conditions. Heat loss is a combination of core loss and wire loss. The number assumes the underlying PCB copper area equals 150% of the component area.

(10) These devices are designed for feed-forward applications, where load current dominates magnetizing current.

VERSA-PAC temperature rise depends on total power losses and size. Any other **PCM** configurations other than those suggested could run hotter than acceptable.

Certain topologies or applications must be analyzed for needed requirements and matched with the best **VERSA-PAC** size and configuration. Proper consideration must be used with all parameters, especially those associated with current rating, energy storage, or maximum volt-seconds.

VERSA-PAC should not be used in off-line or safety related applications. The breakdown voltage from one winding to any other winding is 500 VAC maximum.

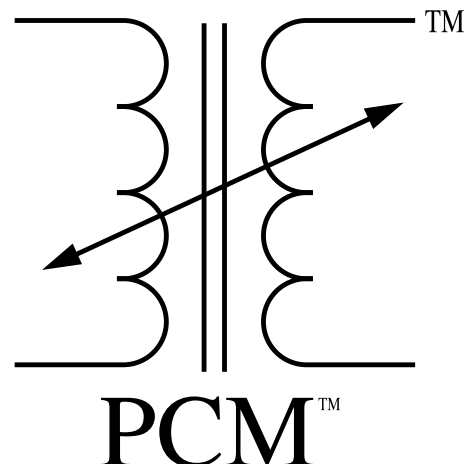

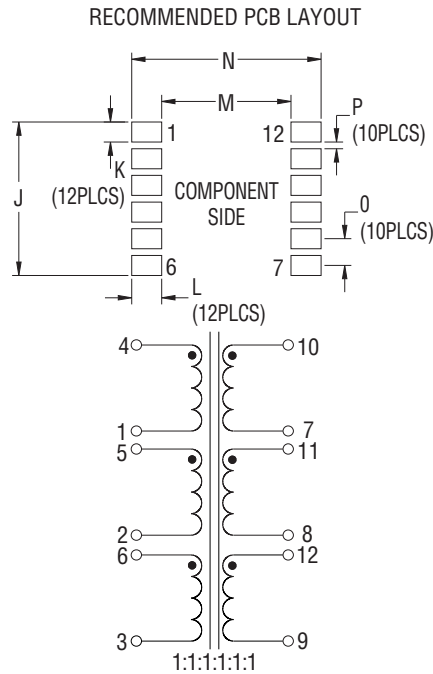
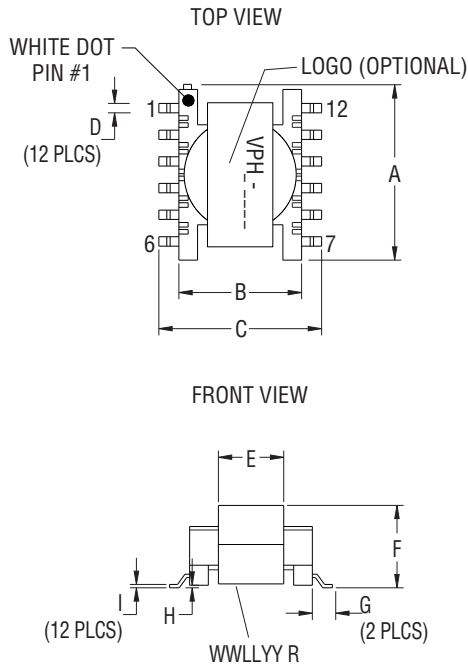
Mechanical Diagrams
VP1 and VPH1

NOTES

- 1) Tolerances A - I are ± 0.25 mm unless specified otherwise.
- 2) Tolerances J - P are ± 0.1 mm unless specified otherwise.
- 3) Marking as shown
 - a) Dot for pin #1 identification
 - b) On top of unit: -- VPHx-xxx (product code, size, 4 digit part number per family table.)
 - c) On top of unit: Versa Pac Logo (optional)
 - d) On bottom of unit: wlllyy = (date code) R = (revision level)
- 4) All soldering surfaces must be coplanar within 0.102 mm.

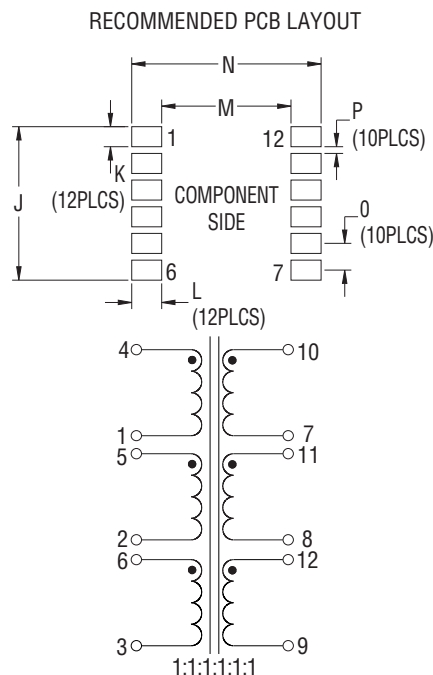
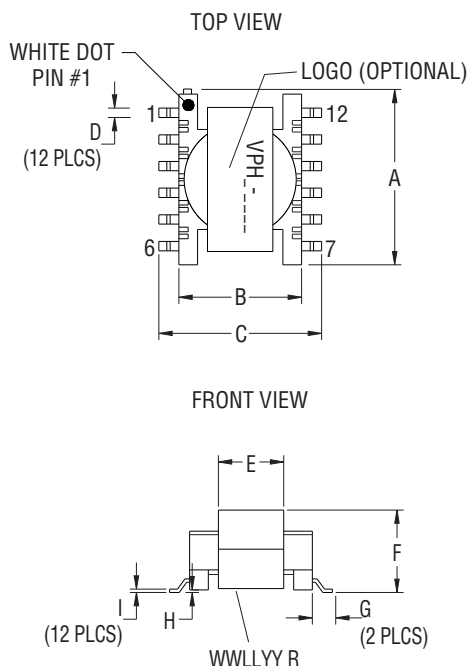
	A mm max	B mm ref	C mm max	D mm ref	E mm ref	F mm max	G mm ref	H mm ref	I mm ref	J mm ref	K mm	L mm	M mm ref	N mm max	O mm	P mm
VP1 and VPH1	12.9	9.2	13.0	0.7	5.9	6.2	1.5	0.1	0.25	11.5	1.5	2.25	9.7	14.2	2.0	0.5

VP2 and VPH2

NOTES

- 1) Tolerances A - I are ± 0.25 mm unless specified otherwise.
- 2) Tolerances J - P are ± 0.1 mm unless specified otherwise.
- 3) Marking as shown
 - a) Dot for pin #1 identification
 - b) On top of unit: -- VPHx-xxx (product code, size, 4 digit part number per family table.)
 - c) On top of unit: Versa Pac Logo (optional)
 - d) On bottom of unit: wlllyy = (date code) R = (revision level)
- 4) All soldering surfaces must be coplanar within 0.102 mm.

	A mm max	B mm ref	C mm max	D mm ref	E mm ref	F mm max	G mm ref	H mm ref	I mm ref	J mm ref	K mm	L mm	M mm ref	N mm max	O mm	P mm
VP2 and VPH2	16.3	12.0	16.8	0.7	6.7	7.8	2.0	0.1	0.30	14.25	1.75	2.5	13.0	18.0	2.5	0.75

Mechanical Diagrams

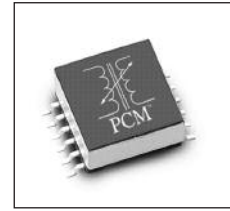
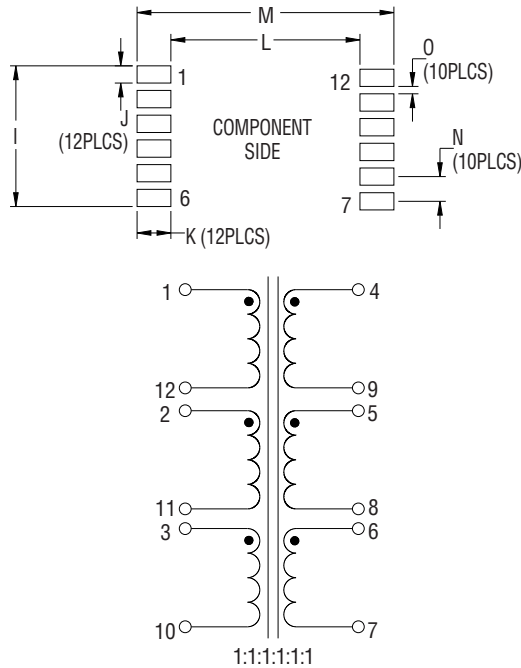
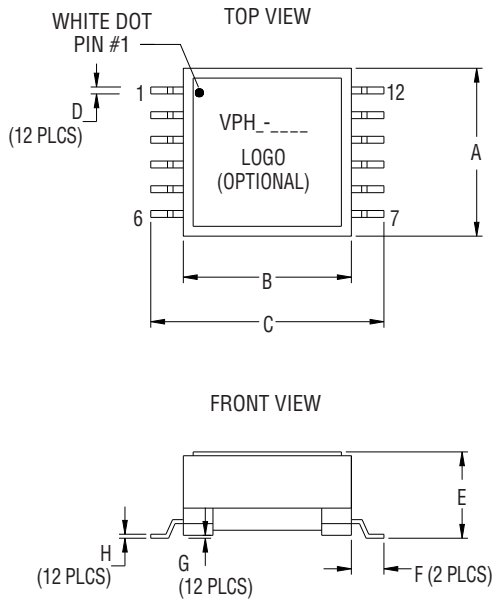
VP3 and VPH3



NOTES

- 1) Tolerances A - I are ± 0.25 mm unless specified otherwise.
- 2) Tolerances J - P are ± 0.1 mm unless specified otherwise.
- 3) Marking as shown
 - a) Dot for pin #1 identification
 - b) On top of unit: -- VPHx-xxx (product code, size, 4 digit part number per family table.)
 - c) On top of unit: Versa Pac Logo (optional)
 - d) On bottom of unit: wwlyyy = (date code) R = (revision level)
- 4) All soldering surfaces must be coplanar within 0.102 mm.

	A	B	C	D	E	F	G	H	I	J	K	L	M	N	O
	mm max	mm ref	mm max	mm ref	mm max	mm ref	mm ref	mm ref	mm ref	mm	mm	mm ref	mm max	mm	mm
VP3 and VPH3	17.1	16.0	22.3	0.7	8.4	3.0	0.1	0.4	14.49	1.79	3.43	16.88	23.74	2.54	0.75

VP4 and VPH4

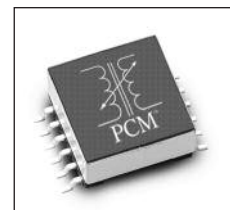
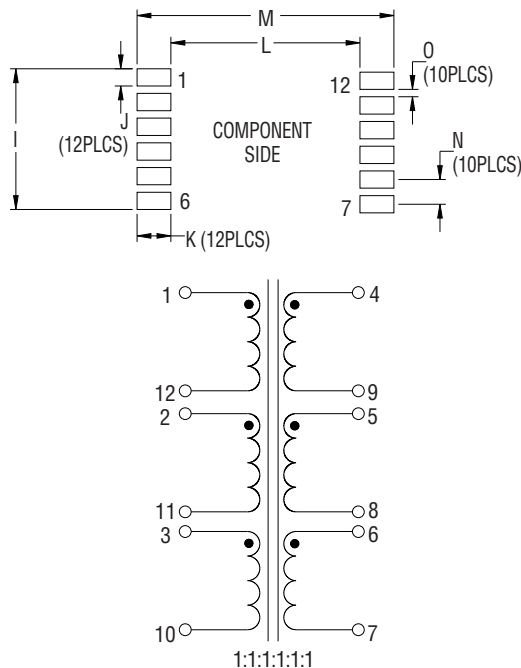
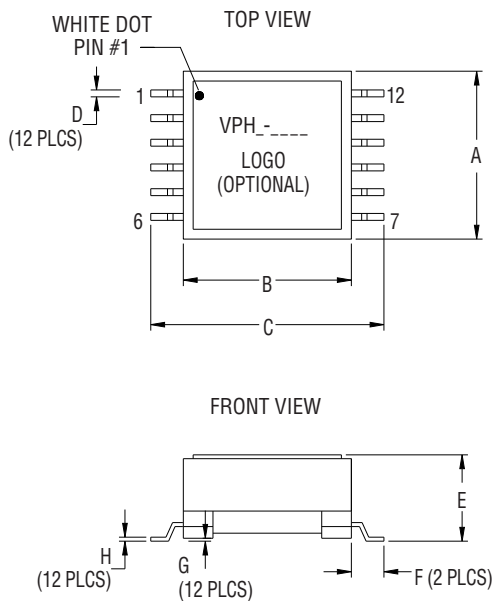

NOTES

- 1) Tolerances A - I are ± 0.25 mm unless specified otherwise.
- 2) Tolerances J - P are ± 0.1 mm unless specified otherwise.
- 3) Marking as shown
 - a) Dot for pin #1 identification
 - b) On top of unit: -- VPHx-xxx (product code, size, 4 digit part number per family table.)
 - c) On top of unit: Versa Pac Logo (optional)
 - d) On bottom of unit: wwlyyy = (date code) R = (revision level)
- 4) All soldering surfaces must be coplanar within 0.102 mm.

	A	B	C	D	E	F	G	H	I	J	K	L	M	N	O
	mm max	mm ref	mm max	mm ref	mm max	mm ref	mm ref	mm ref	mm ref	mm	mm	mm ref	mm max	mm	mm
VP4 and VPH4	18.0	18.0	24.6	0.7	10.0	3.3	0.1	0.4	14.25	1.75	3.43	19.14	26.0	2.5	0.75

Mechanical Diagrams

VP5 and VPH5

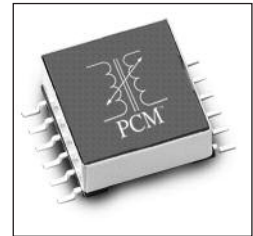
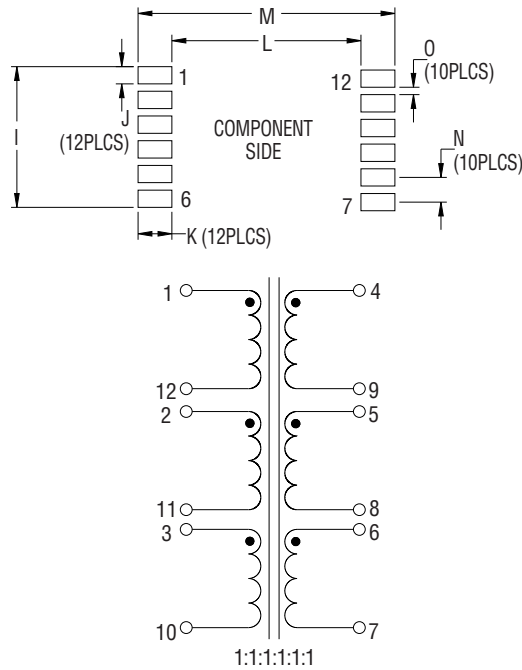
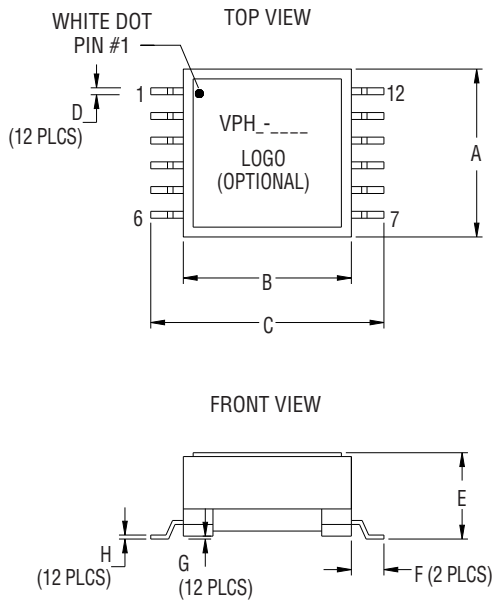
NOTES

- 1) Tolerances A - I are ± 0.25 mm unless specified otherwise.
- 2) Tolerances J - P are ± 0.1 mm unless specified otherwise.
- 3) Marking as shown
 - a) Dot for pin #1 identification
 - b) On top of unit: --VPHx-xxx (product code, size, 4 digit part number per family table.)
 - c) On top of unit: Versa Pac Logo (optional)
 - d) On bottom of unit: wwlyyy = (date code) R = (revision level)
- 4) All soldering surfaces must be coplanar within 0.102 mm.

	A mm max	B mm ref	C mm max	D mm ref	E mm max	F mm ref	G mm ref	H mm ref	I mm ref	J mm	K mm	L mm ref	M mm max	N mm	O mm
VP5 and VPH5	21.0	21.0	28.5	0.7	10.8	2.95	0.1	0.4	17.25	2.25	3.15	22.7	29.0	3.0	0.75

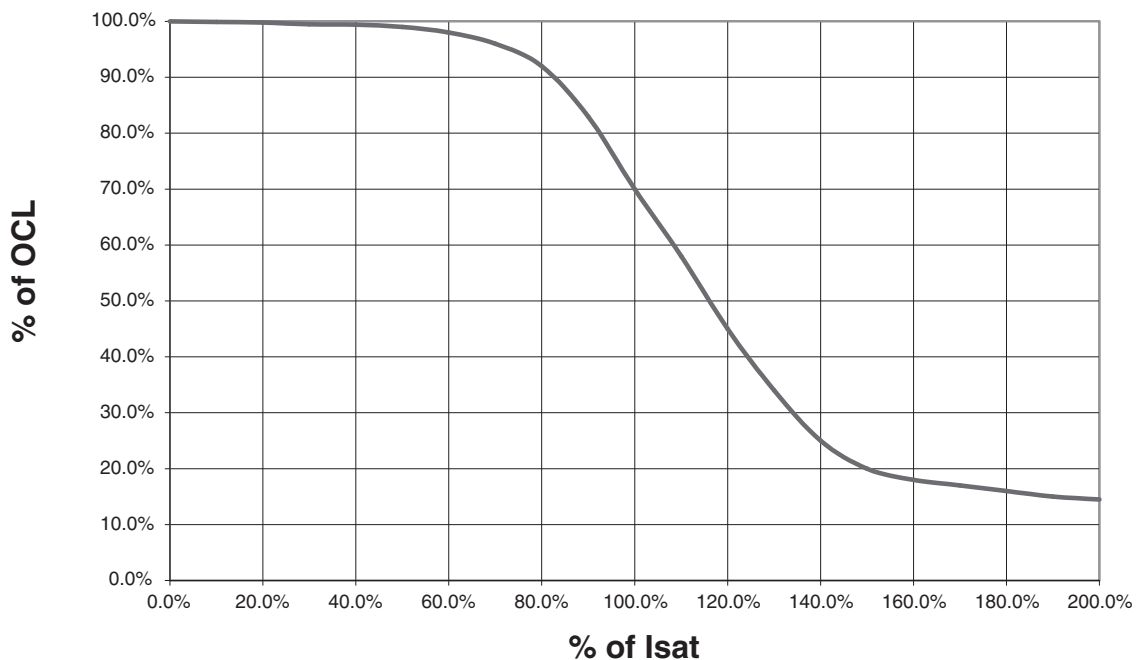
Inductance Characteristics
OCL vs. Isat

HOW TO USE MULTIPLE WINDINGS

Discrete inductors combine like resistors, when connected in series or parallel. For example, inductors in series add and inductors in parallel reduce in a way similar to Ohm's Law.

$$L_{\text{Series}} = L1 + L2 + L3...Ln$$

$$L_{\text{Parallel}} = 1/[1/L1 + 1/L2 + 1/L3....1/Ln]$$

Windings on the same magnetic core behave differently. Two windings in series result in four times the inductance of a single winding. This is because the inductance varies proportionately to the square of the turns.

Paralleled **VERSA-PAC** windings result in no change to the net inductance because the total number of turns remains unchanged; only the effective wire size becomes larger. Two parallel windings result in approximately twice the current carrying capability of a single winding. The net inductance of a given **PCM** configuration is based on the number of windings in series squared multiplied by the inductance of a single winding (L_{BASE}). The current rating of a **PCM** configuration is derived by multiplying the maximum current rating of one winding (I_{BASE}) by the number of windings in parallel. Examples of simple two-winding devices are shown below:

Series Connected (2 Windings)

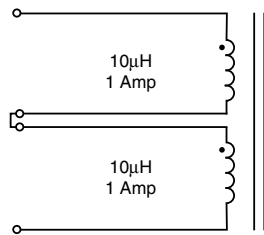

$$L_{\text{TOTAL}} = L_{\text{BASE}} \times S^2 \quad I_{\text{MAX}} = I_{\text{BASE}} \times P$$

$$= 10 \mu\text{H} \times 2^2 \quad = 1 \text{ Amp} \times 1$$

$$= 40 \mu\text{H} \quad = 1 \text{ Amp}$$

Parallel Connected (2 Windings)

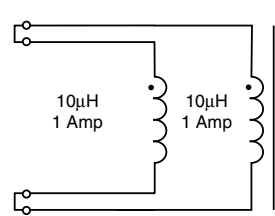

$$L_{\text{TOTAL}} = L_{\text{BASE}} \times S^2 \quad I_{\text{MAX}} = I_{\text{BASE}} \times P$$

$$= 10 \mu\text{H} \times 1^2 \quad = 1 \text{ Amp} \times 2$$

$$= 10 \mu\text{H} \quad = 2 \text{ Amps}$$

Where:

L_{BASE} = Inductance of a single winding

P = Number of windings in parallel (use 1 with all windings in series)

S = Number of windings in series

I_{BASE} = Maximum current rating of one winding

HOW TO PIN-CONFIGURE VERSA-PAC®

Each **VERSA-PAC** can be configured in a variety of ways by simply connecting pins together on the Printed Circuit Board (PCB). As shown below, the connections on the PCB are equal to the pin configuration statement shown at the bottom of the schematic symbol. Connecting a number of windings in parallel will increase the current carrying capability, while connecting in series will multiply the inductance. Each **VERSA-PAC** part can be configured in at least 6 combinations for inductor use or configured in at least 15 turns ratios for transformer applications. Given 25 **VERSA-PAC** part numbers, this allows for at least 500 magnetic configurations. The **PCM** configurations can either be created by the designer or simply chosen from the existing **PCM** diagrams. The following inductor example shows 6 windings in series, which result in an inductance of 36 times the base inductance and 1 times the base current.

INDUCTOR EXAMPLE FOR SIZES VP3, VP4 AND VP5

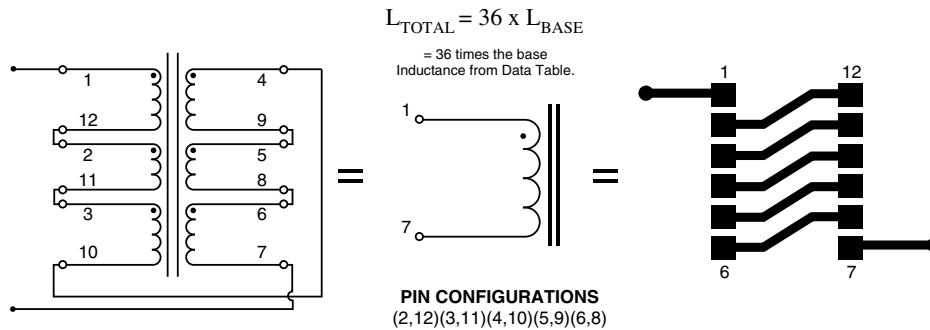

Each **VERSA-PAC** may be used in at least 15 transformer applications. More than 375 transformer combinations may be achieved using the available 25 **VERSA-PAC** parts.

TRANSFORMER EXAMPLE FOR SIZES VP3, VP4 AND VP5

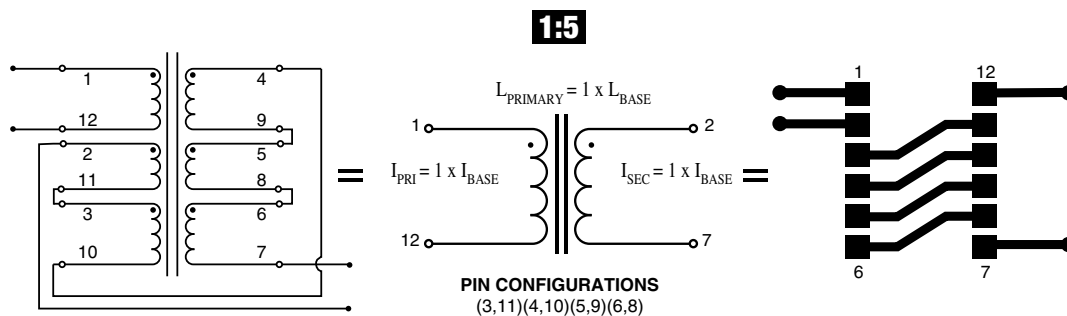

The **PCM** configurations may be selected from the examples on the following pages or created by the designer. Six **PCM** inductor and fifteen **PCM** transformer configurations and equivalent circuit schematics are shown. The printed circuit board layout in each example illustrates the connections to obtain the desired inductance or turns ratio. The examples may be used by the PCB designer to configure **VERSA-PAC** as desired.

To assist the designer, **VERSA-PAC** phasing, coupling and thermal issues have been considered in each of the **PCM** configurations illustrated. Additionally, the inductance and current ratings, as a function of the respective base values from the following Data Tables, are shown in each **PCM** example. Turns ratios are also given for each **PCM** Transformer shown.

It is important to carefully select the proper **VERSA-PAC** part in order to minimize the component size without exceeding the RMS current capability or saturating the core. The Data Tables indicate maximum ratings.

VERSA-PAC® Performance Characteristics

Bipolar (Push-Pull) Power vs Frequency

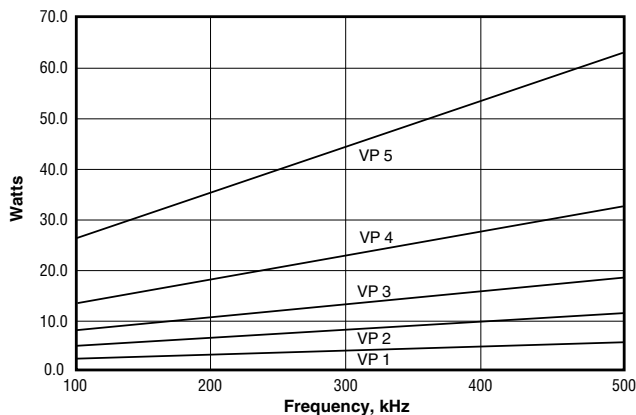

Unipolar (Flyback) Power vs Frequency

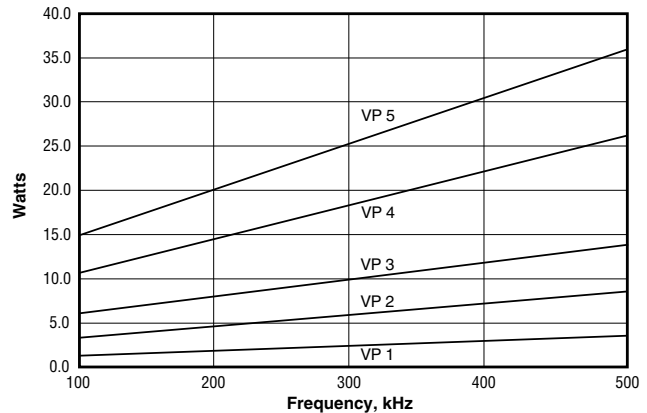

These curves represent typical power handling capability. Indicated power levels may not be achievable with all configurations.

3.3V Buck Converter

This circuit utilizes the gap of the VP5-0083 to handle the 12.5 Amp output current without saturating. In each of the five **VERSA-PAC** sizes, the gap is varied to achieve a selection of specific inductance and current values (see **VERSA-PAC** Data Table).

All six windings are connected in parallel to minimize AC/DC copper losses and to maximize heat dissipation. With **VERSA-PAC**, this circuit works well at or above 300 KHz. Also, the closed flux-path EFD geometry enables much lower radiation characteristics than open-path bobbin core style components.

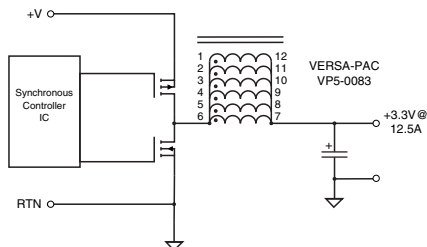

5V to 3.3V Buck Converter With 5V Output

This circuit minimizes both board space and cost by eliminating a second regulator. **VERSA-PAC's** gap serves to prevent core saturation during the switch on-time and also stores energy for the +5V load which is delivered during the flyback interval. The +3.3V buck winding is configured by placing two windings in series while the +5V is generated by an additional flyback winding stacked on the 3.3V output. Extra windings are paralleled with primary windings to handle more current. The turns ratio of 2:1 adds 1.67V to the +3.3V during the flyback interval to achieve +5V.

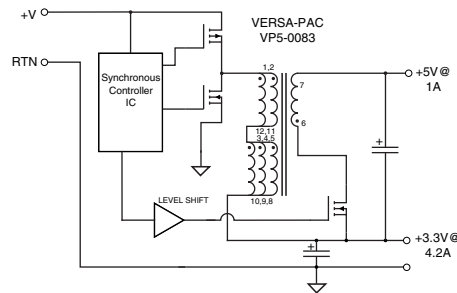

LITHIUM-ION BATTERY TO 3.3V SEPIC CONVERTER

The voltage of a Lithium-Ion Battery varies above and below +3.3V depending on the degree of charge. The SEPIC configuration takes advantage of **VERSA-PAC's** multiple tightly coupled windings. This results in lower ripple current which lowers noise and core losses substantially. The circuit does not require a snubber to control the voltage "spike" associated with switch turn-off, and is quite efficient due to lower RMS current in the windings.

