

## PS9552, PS9552L1, PS9552L2, PS9552L3

**2.5 A OUTPUT CURRENT, HIGH CMR  
IGBT GATE DRIVE PHOTOCOUPLER  
8-PIN DIP PHOTOCOUPLER**

-NEPOC Series-

<R> **DESCRIPTION**

The PS9552, PS9552L1, PS9552L2 and PS9552L3 are optically coupled isolators containing a GaAlAs LED on the input side and a photo diode, a signal processing circuit and a power output transistor on the output side on one chip.

The PS9552 Series is designed specifically for high common mode transient immunity (CMR), high output current and high switching speed.

The PS9552 Series is suitable for driving IGBTs and MOS FETs.

The PS9552 Series is in a plastic DIP (Dual In-line Package).

The PS9552L1 is lead bending type for long creepage distance.

The PS9552L2 is lead bending type for long creepage distance (Gull-wing) for surface mount.

The PS9552L3 is lead bending type (Gull-wing) for surface mounting.

**FEATURES**

- <R> • Large peak output current (2.5 A MAX., 2.0 A MIN.)
- High speed switching ( $t_{PLH}/t_{PHL} = 0.5 \mu s$  MAX.)
- UVLO (Under Voltage Lock Out) protection with hysteresis
- High common mode transient immunity ( $CM_H, CM_L = \pm 15 kV/\mu s$  MIN.)
- <R> • Ordering number of tape product : PS9552L2-E3 : 1 000 pcs/reel  
: PS9552L3-E3 : 1 000 pcs/reel
- <R> • Safety standards
  - UL approved: File No. E72422
  - CSA approved: No. CA 101391
  - BSI approved: No. 8937, 8938
  - SEMKO approved: No. 615433
  - NEMKO approved: No. P06207243
  - DEMKO approved: No. 314091
  - FIMKO approved: No. FI 22827
  - DIN EN60747-5-2 (VDE0884 Part2) approved (Option)

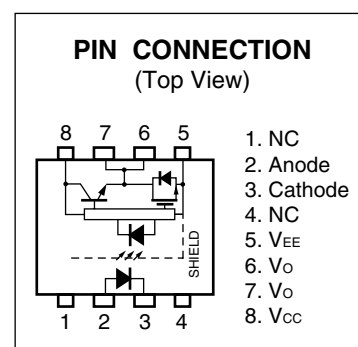
**APPLICATIONS**

- IGBT, Power MOS FET Gate Driver
- Industrial inverter
- IH (Induction Heating)

The information in this document is subject to change without notice. Before using this document, please confirm that this is the latest version.

Not all products and/or types are available in every country. Please check with an NEC Electronics sales representative for availability and additional information.

<R> PACKAGE DIMENSIONS (UNIT: mm)

DIP Type

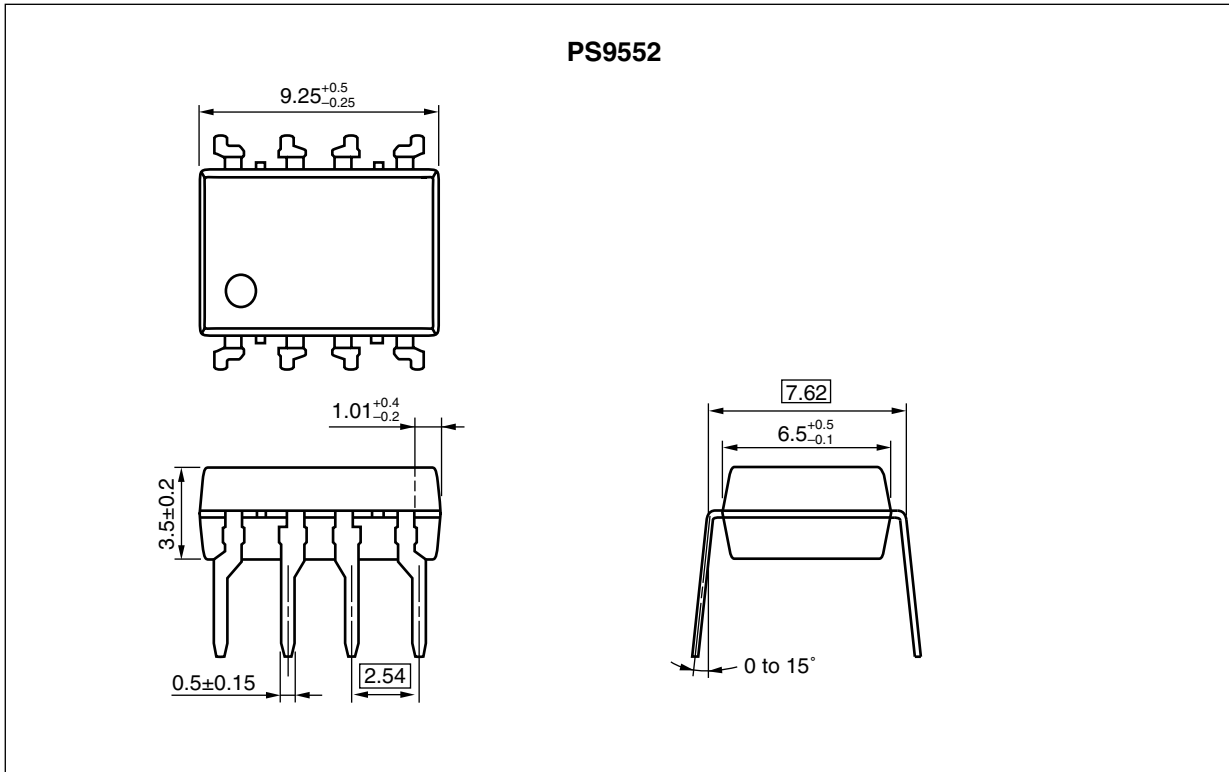

Lead Bending Type (Gull-wing) For Surface Mount

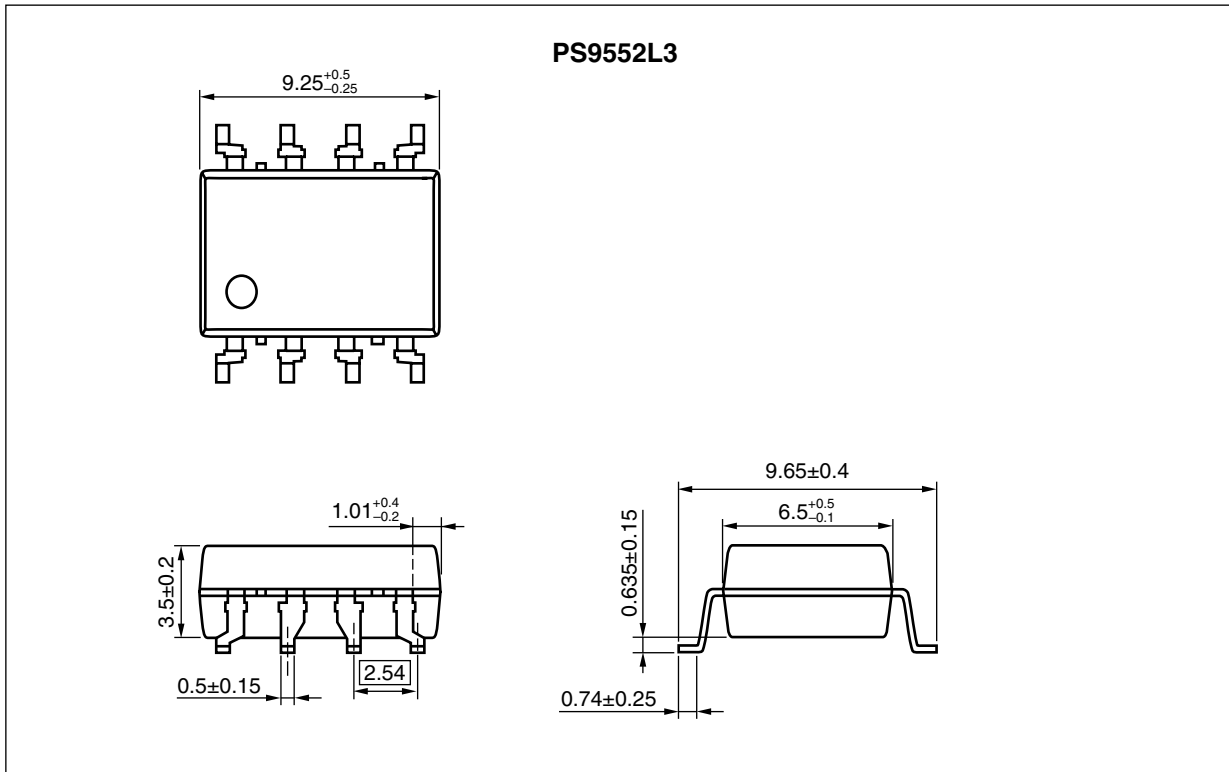

Lead Bending Type For Long Creepage Distance

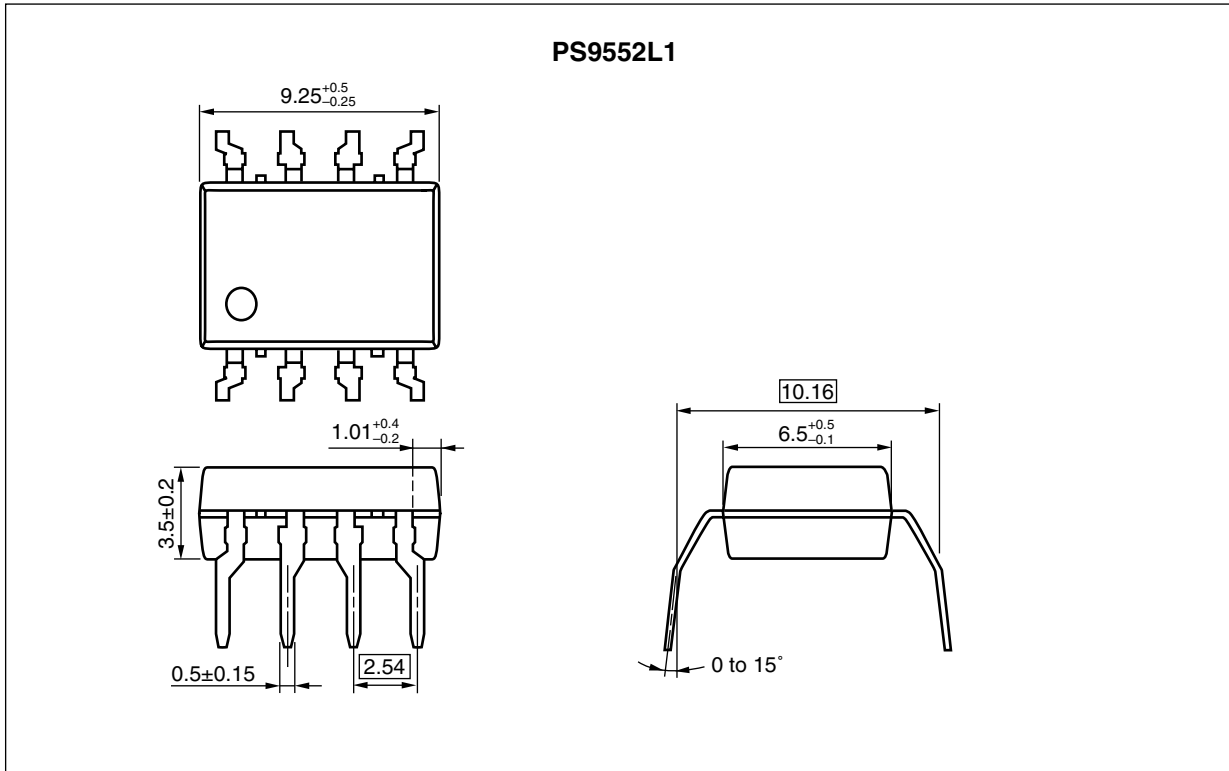

Lead Bending Type (Gull-wing) For Long Creepage Distance (Surface Mount)

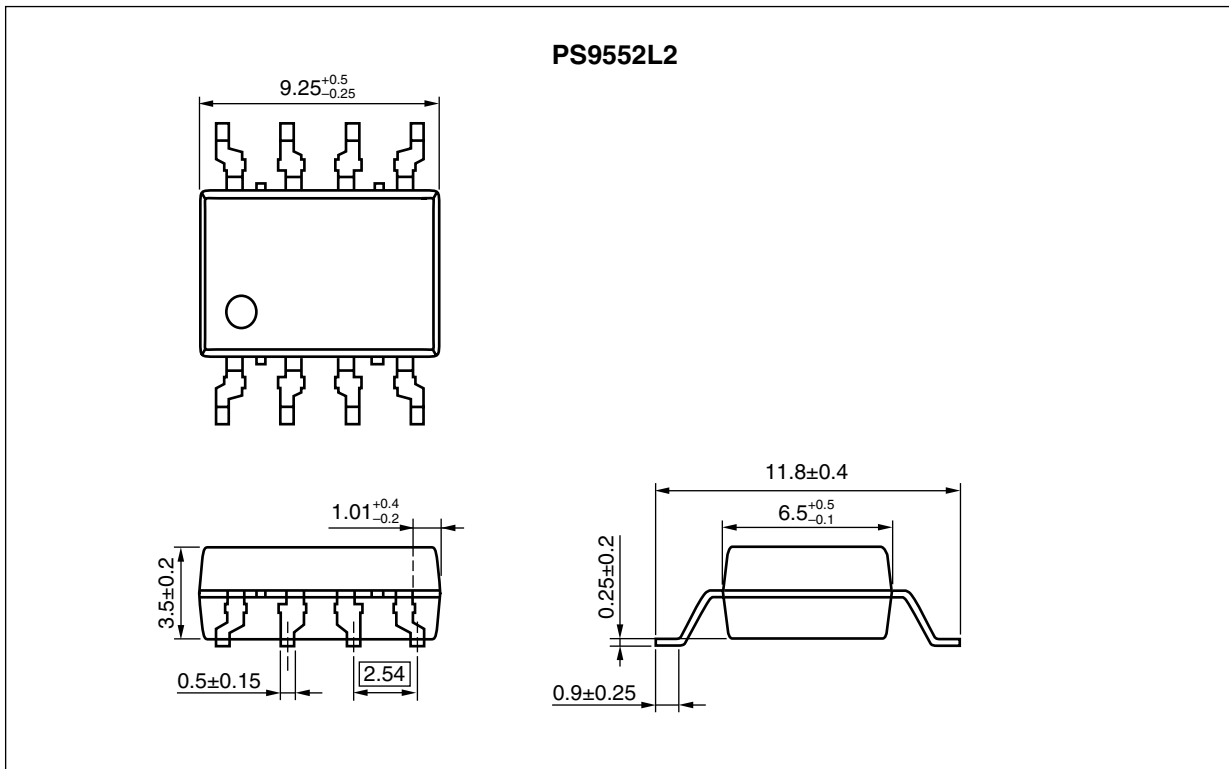

<R> **MARKING EXAMPLE**

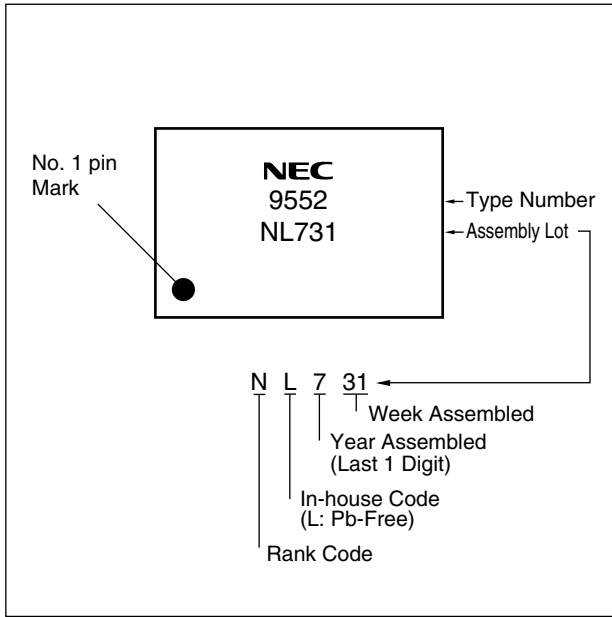

<R> **PHOTOCOUPLER CONSTRUCTION**

Parameter	PS9552, PS9552L3	PS9552L1, PS9552L2
Air Distance (MIN.)	7 mm	8 mm
Outer Creepage Distance (MIN.)	7 mm	8 mm
Isolation Distance (MIN.)	0.4 mm	0.4 mm

<R> **ORDERING INFORMATION**

Part Number	Order Number	Solder Plating Specification	Packing Style	Safety Standard Approval	Application Part Number <sup>*1</sup>
PS9552	PS9552-AX	Pb-Free (Ni/Pd/Au)	Magazine case 50 pcs	Standard products (UL, CSA, BSI, SEMKO, NEMKO, DEMKO, FIMKO approved)	PS9552
PS9552L1	PS9552L1-AX				
PS9552L2	PS9552L2-AX				
PS9552L3	PS9552L3-AX				
PS9552L2-E3	PS9552L2-E3-AX				
PS9552L3-E3	PS9552L3-E3-AX				
PS9552L2-E3	PS9552L2-E3-AX		Embossed Tape 1 000 pcs/reel	DIN EN60747-5-2 (VDE0884 Part2) Approved (Option)	
PS9552L3-E3	PS9552L3-E3-AX				
PS9552-V	PS9552-V-AX		Magazine case 50 pcs		
PS9552L1-V	PS9552L1-V-AX				
PS9552L2-V	PS9552L2-V-AX				
PS9552L3-V	PS9552L3-V-AX				
PS9552L2-V-E3	PS9552L2-V-E3-AX	Embossed Tape 1 000 pcs/reel			
PS9552L3-V-E3	PS9552L3-V-E3-AX				

\*1 For the application of the Safety Standard, following part number should be used.

<R> **ABSOLUTE MAXIMUM RATINGS (T<sub>A</sub> = 25°C, unless otherwise specified)**

Parameter		Symbol	Ratings	Unit
Diode	Forward Current	I <sub>F</sub>	25	mA
	Peak Transient Forward Current (Pulse Width < 1 μs)	I <sub>F (TRAN)</sub>	1.0	A
	Reverse Voltage	V <sub>R</sub>	5	V
Detector	High Level Peak Output Current <sup>*1</sup>	I <sub>OH (PEAK)</sub>	2.5	A
	Low Level Peak Output Current <sup>*1</sup>	I <sub>OL (PEAK)</sub>	2.5	A
	Supply Voltage	(V <sub>CC</sub> - V <sub>EE</sub> )	0 to 35	V
	Output Voltage	V <sub>O</sub>	0 to V <sub>CC</sub>	V
	Output Power Dissipation <sup>*2</sup>	P <sub>O</sub>	250	mW
Isolation Voltage <sup>*3</sup>		BV	5 000	Vr.m.s.
Total Power Dissipation <sup>*4</sup>		P <sub>T</sub>	300	mW
Operating Frequency <sup>*5</sup>		f	50	kHz
Operating Ambient Temperature		T <sub>A</sub>	-40 to +100	°C
Storage Temperature		T <sub>stg</sub>	-55 to +125	°C

\*1 Maximum pulse width = 10 μs, Maximum duty cycle = 0.2%

\*2 Reduced to 4.8 mA/°C at T<sub>A</sub> = 70°C or more.

\*3 AC voltage for 1 minute at T<sub>A</sub> = 25°C, RH = 60% between input and output.  
Pins 1-4 shorted together, 5-8 shorted together.

\*4 Reduced to 5.4 mA/°C at T<sub>A</sub> = 70°C or more.

\*5 I<sub>OH (PEAK)</sub> ≤ 2.0 A (≤ 0.3 μs), I<sub>OL (PEAK)</sub> ≤ 2.0 A (≤ 0.3 μs)

**RECOMMENDED OPERATING CONDITIONS**

Parameter	Symbol	MIN.	TYP.	MAX.	Unit
Supply Voltage	(V <sub>CC</sub> - V <sub>EE</sub> )	15		30	V
Forward Current (ON)	I <sub>F (ON)</sub>	7	10	16	mA
Forward Voltage (OFF)	V <sub>F (OFF)</sub>	-2		0.8	V
Operating Ambient Temperature	T <sub>A</sub>	-40		100	°C

<R>

<R> **ELECTRICAL CHARACTERISTICS** ( $T_A = -40$  to  $+100^\circ\text{C}$ ,  $V_{CC} = 15$  to  $30$  V,  $I_F(\text{ON}) = 7$  to  $16$  mA,  $V_F(\text{OFF}) = -2$  to  $0.8$  V,  $V_{EE} = \text{GND}$ , unless otherwise specified)

Parameter		Symbol	Conditions	MIN.	TYP.*1	MAX.	Unit
Diode	Forward Voltage	$V_F$	$I_F = 10$ mA, $T_A = 25^\circ\text{C}$	1.3	1.65	2.1	V
	Input Capacitance	$C_{IN}$	$f = 1$ MHz, $V_F = 0$ V, $T_A = 25^\circ\text{C}$		60		pF
Detector	High Level Output Current	$I_{OH}$	$V_O = (V_{CC} - 4 \text{ V})^{*2}$	0.5	2.0		A
			$V_O = (V_{CC} - 15 \text{ V})^{*3}$	2.0			
	Low Level Output Current	$I_{OL}$	$V_O = (V_{EE} + 2.5 \text{ V})^{*2}$	0.5	2.0		A
			$V_O = (V_{EE} + 15 \text{ V})^{*3}$	2.0			
	High Level Output Voltage	$V_{OH}$	$I_O = -100$ mA <sup>*4</sup>	$V_{CC} - 3.5$	$V_{CC} - 2.5$	$V_{CC} - 1.5$	V
	Low Level Output Voltage	$V_{OL}$	$I_O = 100$ mA		0.1	0.5	V
	High Level Supply Current	$I_{CCH}$	$V_O = \text{open}$ , $I_F = 7$ to $16$ mA		2.0	5.0	mA
	Low Level Supply Current	$I_{CCL}$	$V_O = \text{open}$ , $V_F = 0$ to $+0.8$ V		2.0	5.0	mA
	UVLO Threshold	$V_{UVLO+}$	$V_O > 5$ V, $I_F = 10$ mA	11.0	12.3	13.5	V
		$V_{UVLO-}$		9.5	10.7	12.0	
UVLO Hysteresis	$UVLO_{HYS}$	$V_O > 5$ V, $I_F = 10$ mA		1.6		V	
Coupled	Threshold Input Current (L → H)	$I_{FLH}$	$I_O = 0$ mA, $V_O > 5$ V		2.0	5.0	mA
	Threshold Input Voltage (H → L)	$V_{FHL}$	$I_O = 0$ mA, $V_O > 5$ V	0.8			V

\*1 Typical values at  $T_A = 25^\circ\text{C}$ .

\*2 Maximum pulse width = 50  $\mu\text{s}$ , Maximum duty cycle = 0.5%.

\*3 Maximum pulse width = 10  $\mu\text{s}$ , Maximum duty cycle = 0.2%

\*4  $V_{OH}$  is measured with the DC load current in this testing (Maximum pulse width = 2 ms, Maximum duty cycle = 20%).

<R> **SWITCHING CHARACTERISTICS** ( $T_A = -40$  to  $+100^\circ\text{C}$ ,  $V_{CC} = 15$  to  $30$  V,  $I_F(\text{ON}) = 7$  to  $16$  mA,  $V_F(\text{OFF}) = -2$  to  $0.8$  V,  $V_{EE} = \text{GND}$ , unless otherwise specified)

Parameter	Symbol	Conditions	MIN.	TYP.*1	MAX.	Unit
Propagation Delay Time (L → H)	$t_{PLH}$	$R_g = 10 \Omega$ , $C_g = 10 \text{ nF}$ , $f = 10 \text{ kHz}$ , Duty Cycle = 50%*2	0.1	0.3	0.5	$\mu\text{s}$
Propagation Delay Time (H → L)	$t_{PHL}$		0.1	0.3	0.5	$\mu\text{s}$
Pulse Width Distortion (PWD)	$ t_{PHL} - t_{PLH} $				0.3	$\mu\text{s}$
Propagation Delay Time (Difference Between Any Two Products)	$t_{PHL} - t_{PLH}$		-0.35		0.35	$\mu\text{s}$
Rise Time	$t_r$			0.1		$\mu\text{s}$
Fall Time	$t_f$			0.1		$\mu\text{s}$
UVLO (Turn On Delay)	$t_{UVLO \text{ ON}}$	$V_O > 5 \text{ V}$ , $I_F = 10 \text{ mA}$		0.8		$\mu\text{s}$
UVLO (Turn Off Delay)	$t_{UVLO \text{ OFF}}$	$V_O < 5 \text{ V}$ , $I_F = 10 \text{ mA}$		0.6		$\mu\text{s}$
Common Mode Transient Immunity at High Level Output*3	$CM_H$	$T_A = 25^\circ\text{C}$ , $I_F = 10 \text{ mA}$ , $V_{O(\text{MIN.})} = 26 \text{ V}$ , $V_{CM} = 1.5\text{k V}$	15			$\text{kV}/\mu\text{s}$
Common Mode Transient Immunity at Low Level Output*3	$CM_L$	$T_A = 25^\circ\text{C}$ , $I_F = 0 \text{ mA}$ , $V_{O(\text{MAX.})} = 1 \text{ V}$ , $V_{CM} = 1.5\text{k V}$	15			$\text{kV}/\mu\text{s}$

\*1 Typical values at  $T_A = 25^\circ\text{C}$ .

\*2 This load condition is equivalent to the IGBT load at 1 200 V/75 A.

\*3 Connect pin 1 and pin 4 to the LED common.



<R> TEST CIRCUIT

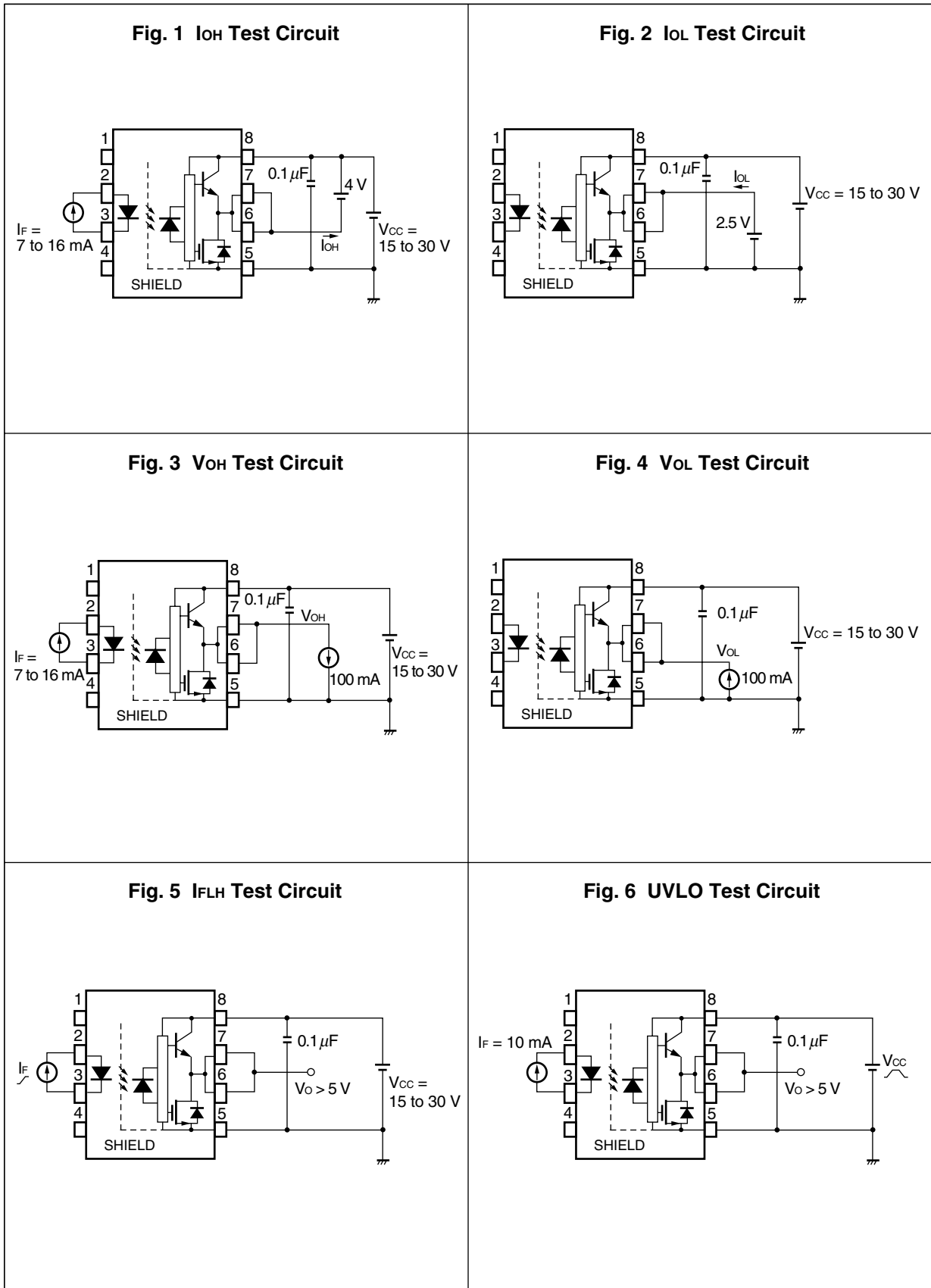

Fig. 7  $t_{PLH}$ ,  $t_{PHL}$ ,  $t_r$ ,  $t_f$  Test Circuit and Wave Forms

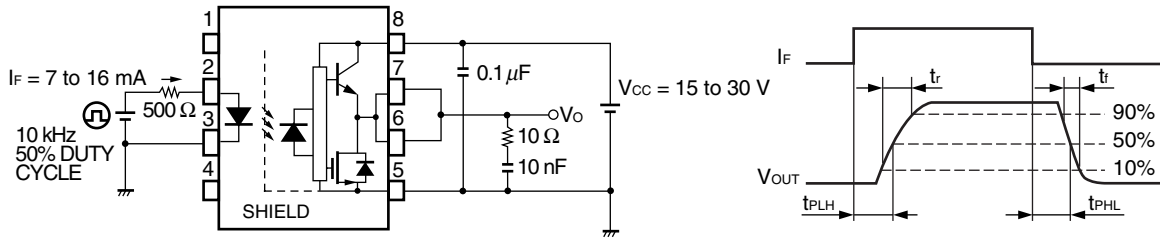
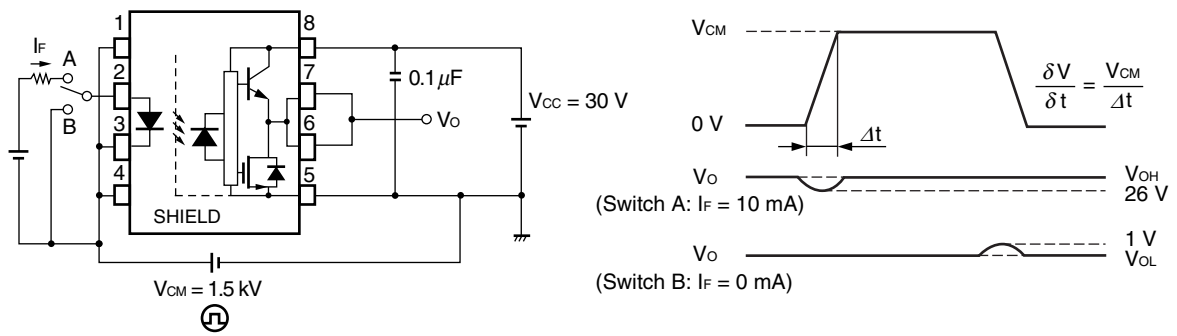

Fig. 8 CMR Test Circuit and Wave Forms



**Remark** CMR Test : Connect pin 1 and pin 4 to the LED common.

<R> TAPING SPECIFICATIONS (UNIT: mm)

Outline and Dimensions (Tape)

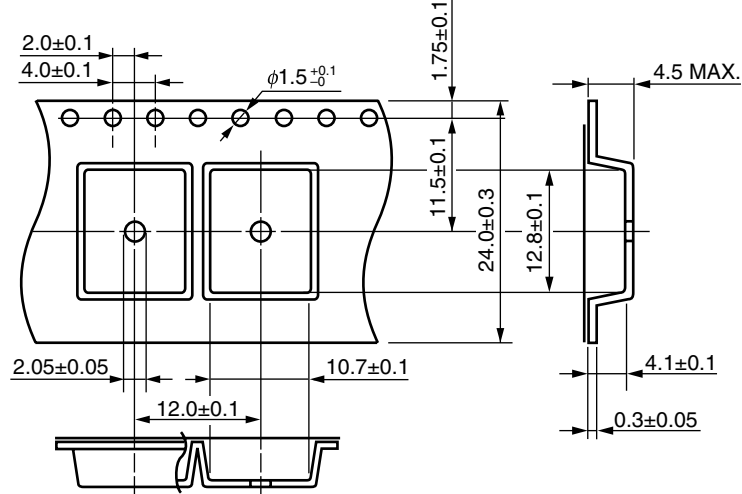

Tape Direction

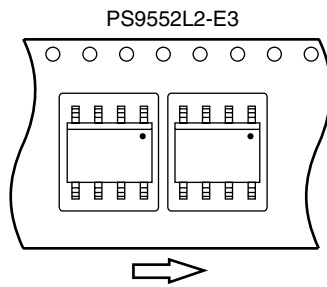

Outline and Dimensions (Reel)

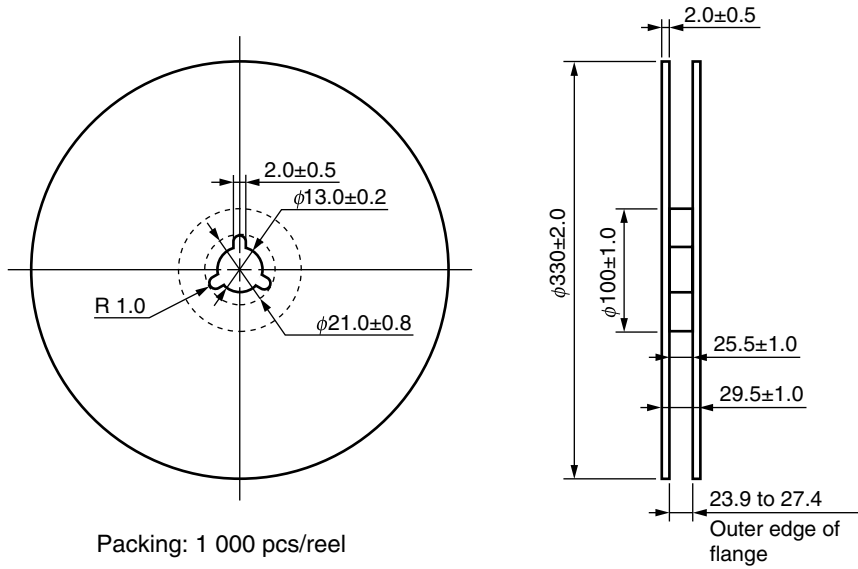

Outline and Dimensions (Tape)

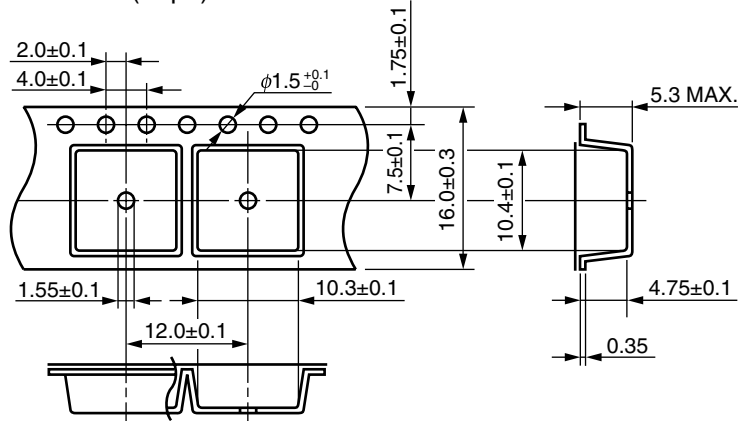

Tape Direction

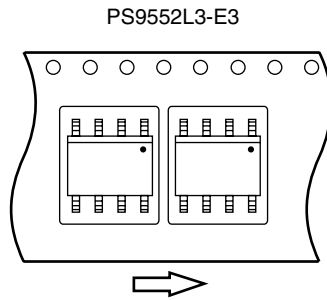

Outline and Dimensions (Reel)

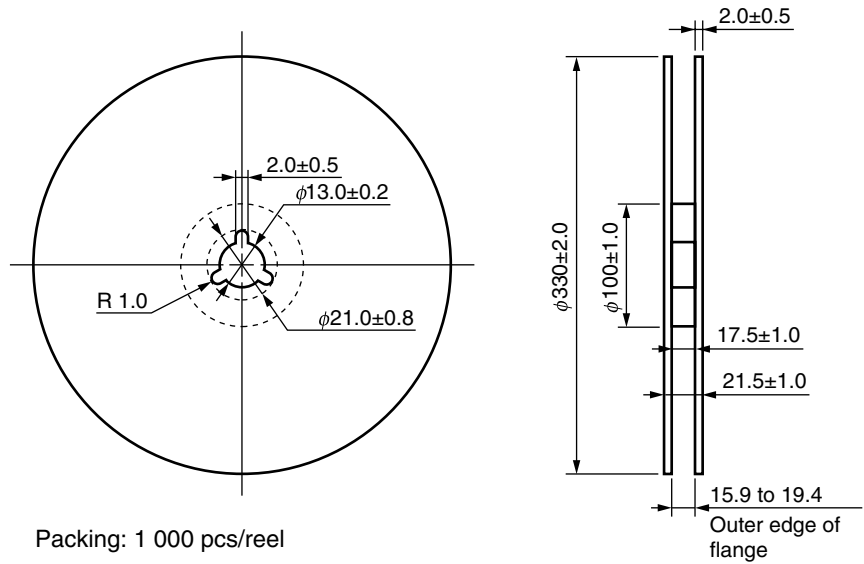

**NOTES ON HANDLING**

**1. Recommended soldering conditions**

**(1) Infrared reflow soldering**

- Peak reflow temperature 260°C or below (package surface temperature)
- Time of peak reflow temperature 10 seconds or less
- Time of temperature higher than 220°C 60 seconds or less
- Time to preheat temperature from 120 to 180°C 120±30 s
- Number of reflows Three
- Flux Rosin flux containing small amount of chlorine (The flux with a maximum chlorine content of 0.2 Wt% is recommended.)

Recommended Temperature Profile of Infrared Reflow

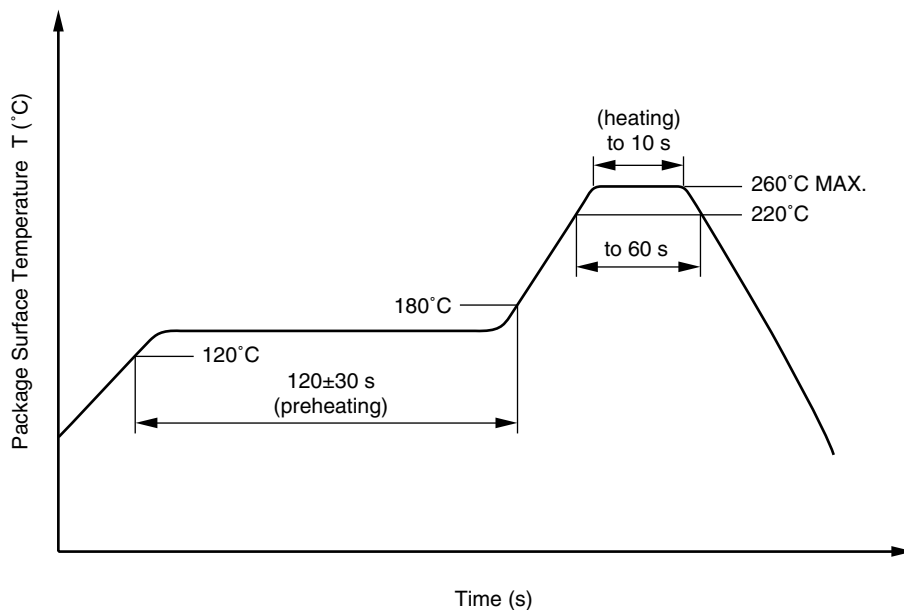

**(2) Wave soldering**

- Temperature 260°C or below (molten solder temperature)
- Time 10 seconds or less
- Preheating conditions 120°C or below (package surface temperature)
- Number of times One (Allowed to be dipped in solder including plastic mold portion.)
- Flux Rosin flux containing small amount of chlorine (The flux with a maximum chlorine content of 0.2 Wt% is recommended.)

**(3) Soldering by Soldering Iron**

- Peak Temperature (lead part temperature) 350°C or below
- Time (each pins) 3 seconds or less
- Flux Rosin flux containing small amount of chlorine (The flux with a maximum chlorine content of 0.2 Wt% is recommended.)

- (a) Soldering of leads should be made at the point 1.5 to 2.0 mm from the root of the lead
- (b) Please be sure that the temperature of the package would not be heated over 100°C

**(4) Cautions**

## • Fluxes

Avoid removing the residual flux with freon-based and chlorine-based cleaning solvent.

**2. Cautions regarding noise**

Be aware that when voltage is applied suddenly between the photocoupler's input and output or between collector-emitters at startup, the output transistor may enter the on state, even if the voltage is within the absolute maximum ratings.

**USAGE CAUTIONS**

1. This product is weak for static electricity by designed with high-speed integrated circuit so protect against static electricity when handling.
- <R> 2. By-pass capacitor of more than 0.1  $\mu$ F is used between V<sub>CC</sub> and GND near device. Also, ensure that the distance between the leads of the photocoupler and capacitor is no more than 10 mm.
- <R> 3. In the layout of the board, be sure that the IGBT collector and emitter patterns are not close to this product's input. If they are allocated close to the input and the transient currents may be combined, the transient current on the IGBT side may unexpectedly be input into the LED input of this product, causing malfunctions and degradation in characteristics (When it is necessary to allocate patterns close to the input, design the input drive circuit so that the LED has reverse bias in the off state to prevent the LED lighting in the off state).
4. Avoid storage at a high temperature and high humidity.

• **The information in this document is current as of June, 2007. The information is subject to change without notice. For actual design-in, refer to the latest publications of NEC Electronics data sheets or data books, etc., for the most up-to-date specifications of NEC Electronics products. Not all products and/or types are available in every country. Please check with an NEC Electronics sales representative for availability and additional information.**

- No part of this document may be copied or reproduced in any form or by any means without the prior written consent of NEC Electronics. NEC Electronics assumes no responsibility for any errors that may appear in this document.
- NEC Electronics does not assume any liability for infringement of patents, copyrights or other intellectual property rights of third parties by or arising from the use of NEC Electronics products listed in this document or any other liability arising from the use of such products. No license, express, implied or otherwise, is granted under any patents, copyrights or other intellectual property rights of NEC Electronics or others.
- Descriptions of circuits, software and other related information in this document are provided for illustrative purposes in semiconductor product operation and application examples. The incorporation of these circuits, software and information in the design of a customer's equipment shall be done under the full responsibility of the customer. NEC Electronics assumes no responsibility for any losses incurred by customers or third parties arising from the use of these circuits, software and information.
- While NEC Electronics endeavors to enhance the quality, reliability and safety of NEC Electronics products, customers agree and acknowledge that the possibility of defects thereof cannot be eliminated entirely. To minimize risks of damage to property or injury (including death) to persons arising from defects in NEC Electronics products, customers must incorporate sufficient safety measures in their design, such as redundancy, fire-containment and anti-failure features.
- NEC Electronics products are classified into the following three quality grades: "Standard", "Special" and "Specific".

The "Specific" quality grade applies only to NEC Electronics products developed based on a customer-designated "quality assurance program" for a specific application. The recommended applications of an NEC Electronics product depend on its quality grade, as indicated below. Customers must check the quality grade of each NEC Electronics product before using it in a particular application.

"Standard": Computers, office equipment, communications equipment, test and measurement equipment, audio and visual equipment, home electronic appliances, machine tools, personal electronic equipment and industrial robots.

"Special": Transportation equipment (automobiles, trains, ships, etc.), traffic control systems, anti-disaster systems, anti-crime systems, safety equipment and medical equipment (not specifically designed for life support).

"Specific": Aircraft, aerospace equipment, submersible repeaters, nuclear reactor control systems, life support systems and medical equipment for life support, etc.

The quality grade of NEC Electronics products is "Standard" unless otherwise expressly specified in NEC Electronics data sheets or data books, etc. If customers wish to use NEC Electronics products in applications not intended by NEC Electronics, they must contact an NEC Electronics sales representative in advance to determine NEC Electronics' willingness to support a given application.

(Note)

- (1) "NEC Electronics" as used in this statement means NEC Electronics Corporation and also includes its majority-owned subsidiaries.
- (2) "NEC Electronics products" means any product developed or manufactured by or for NEC Electronics (as defined above).

<p><b>Caution</b> GaAs Products</p>	<p>This product uses gallium arsenide (GaAs). GaAs vapor and powder are hazardous to human health if inhaled or ingested, so please observe the following points.</p> <ul style="list-style-type: none"> <li>• Follow related laws and ordinances when disposing of the product. If there are no applicable laws and/or ordinances, dispose of the product as recommended below.             <ol style="list-style-type: none"> <li>1. Commission a disposal company able to (with a license to) collect, transport and dispose of materials that contain arsenic and other such industrial waste materials.</li> <li>2. Exclude the product from general industrial waste and household garbage, and ensure that the product is controlled (as industrial waste subject to special control) up until final disposal.</li> </ol> </li> <li>• Do not burn, destroy, cut, crush, or chemically dissolve the product.</li> <li>• Do not lick the product or in any way allow it to enter the mouth.</li> </ul>
-------------------------------------	---