



75W DC-DC Half-Brick Regulated Single Output Converter

MHB75 series



■ Features :

- Half-brick size (2.28"X2.4"X0.5") with industry standard pin out
- 2:1 wide input range
- Protections: Short circuit / Over current / Over voltage / Over temperature
- High efficiency up to 89%
- 1500VDC I/O isolation
- Built-in remote ON/OFF control
- Built-in remote sense function
- Trimming output $\pm 10\%$
- Five-sided shield metal case
- Optional heat sinks for extended operating temperature
- Output 2.5V/3.3V/15V available
- Approvals: UL / CUL / CE
- 3 years warranty



SPECIFICATION

MODEL		MHB75-12S05	MHB75-12S12	MHB75-12S24	MHB75-24S05	MHB75-24S12	MHB75-24S24	MHB75-48S05	MHB75-48S12	MHB75-48S24	
OUTPUT	DC VOLTAGE	5V	12V	24V	5V	12V	24V	5V	12V	24V	
	CURRENT RANGE	0 ~ 15A	0 ~ 6.25A	0 ~ 3.13A	0 ~ 15A	0 ~ 6.25A	0 ~ 3.13A	0 ~ 15A	0 ~ 6.25A	0 ~ 3.13A	
	RATED POWER	75W									
	RIPPLE & NOISE (max.) Note.2	75mVp-p	100mVp-p	240mVp-p	75mVp-p	100mVp-p	240mVp-p	75mVp-p	100mVp-p	240mVp-p	
	VOLTAGE ACCURACY Note.3	$\pm 1.0\%$									
	LINE REGULATION	$\pm 0.2\%$									
	LOAD REGULATION	$\pm 0.2\%$									
	SWITCHING FREQUENCY (Typ.)	400KHz for 12/24Vin, 300KHz for 48Vin									
	EXTERNAL TRIM ADJ. RANGE (Typ.)	$\pm 10\%$									
EXTERNAL CAPACITIVE LOAD (max.)	10000uF	10000uF	2000uF	10000uF	10000uF	2000uF	10000uF	10000uF	2000uF		
INPUT	RATED DC INPUT	12VDC			24VDC			48VDC			
	VOLTAGE RANGE	9 ~ 18VDC			18 ~ 36VDC			36 ~ 75VDC			
	SURGE VOLTAGE (100ms max.)	25VDC			50VDC			100VDC			
	UNDER VOLTAGE LOCKOUT	Power up: 8.8VDC, Power down: 8VDC			Power up: 17VDC, Power down: 16VDC			Power up: 34VDC, Power down: 32.5VDC			
	EFFICIENCY (Typ.)	83%	87%	87%	84%	88%	88%	84%	89%	89%	
	DC CURRENT	FULL LOAD	7570mA	7200mA	7200mA	3780mA	3650mA	3650mA	1900mA	1800mA	1800mA
		NO LOAD	50mA			50mA			50mA		
FILTER	Pi-network										
PROTECTION	OUTPUT OVER CURRENT	110 ~ 150% rated output power Protection type : Over current limiting, recovers automatically after fault condition is removed									
	OUTPUT OVER VOLTAGE (Typ.)	115 ~ 140% rated output voltage Protection type : Output voltage clamp by TVS diode									
	OUTPUT SHORT CIRCUIT	Protection type : Can be continuous, recovers automatically after fault condition is removed									
	OVER TEMPERATURE	100°C $\pm 5^\circ\text{C}$ of case temperature									
FUNCTION OPERATING	REMOTE CONTROL	Please refer to "Remote ON/OFF Control" for details									
	OUTPUT TRIMMING	$\pm 10\%$, Please refer to "External Output Trimming" for details									
ENVIRONMENT	WORKING TEMPERATURE (Typ.)	-40 ~ +100°C ; Thermal shutdown at 100°C $\pm 5^\circ\text{C}$ of case temperature (please refer to "Thermal Curve")									
	WORKING HUMIDITY	0% ~ 95% RH max.									
	STORAGE TEMP., HUMIDITY	-55 ~ +105°C, 0 ~ 95% RH									
	TEMP. COEFFICIENT	$\pm 0.03\%/^\circ\text{C}$ (0~60°C)									
SAFETY & EMC (Note 4)	SAFETY STANDARDS	UL60950-1 approved									
	ISOLATION VOLTAGE	I/P-O/P:1500VDC, I/P-Case:1500VDC, O/P-Case:1500VDC									
	ISOLATION RESISTANCE	I/P-O/P:100M Ohms / 500VDC / 25°C / 70% RH									
	EMC EMISSION	Compliance to EN55032 (CISPR32) Class A with external components (please refer to "EMC Suggestion Circuit")									
	EMC IMMUNITY	Compliance to EN61000-4-2,3,4,5,6,8; EN55024, light industry level, criteria A									
OTHERS	CASE MATERIAL	Aluminum									
	MTBF	1000K hrs typ. MIL-HDBK-217F (25°C)									
	DIMENSION	57.9*61*12.7mm (2.28"*2.40"*0.5") (L*W*H)									
	WEIGHT	92g									
NOTE	<ol style="list-style-type: none"> 1. All parameters NOT specially mentioned are measured at 12,24,48VDC input, rated load and 25°C of ambient temperature. 2. Ripple & noise are measured at 20MHz of bandwidth by using a 12" twisted pair-wire terminated with a 1uf ceramic & 10uf tantalum capacitor across output. 3. The power supply need to connect "+Vout" to "+R.S" and "-Vout" to "-R.S". 4. The power supply is considered a component which will be installed into a final equipment. The final equipment must be re-confirmed that it still meets EMC directives. For guidance on how to perform these EMC tests, please refer to "EMI testing of component power supplies." 										

Mechanical Specification

Unit:inch[mm]

All Dimensions In Inches [mm]
 Tolerance Inches: X.XX= ±0.02 , X.XXX= ±0.010
 Millimeters: X.X= ±0.5 , X.XX=±0.25

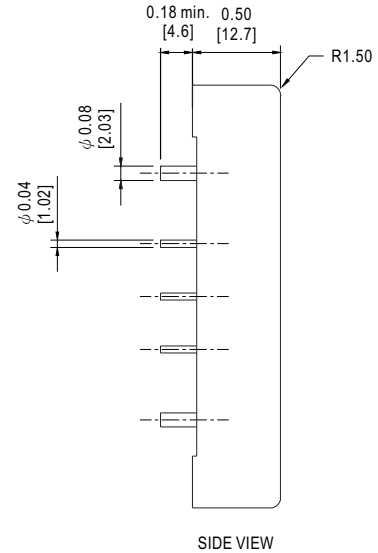
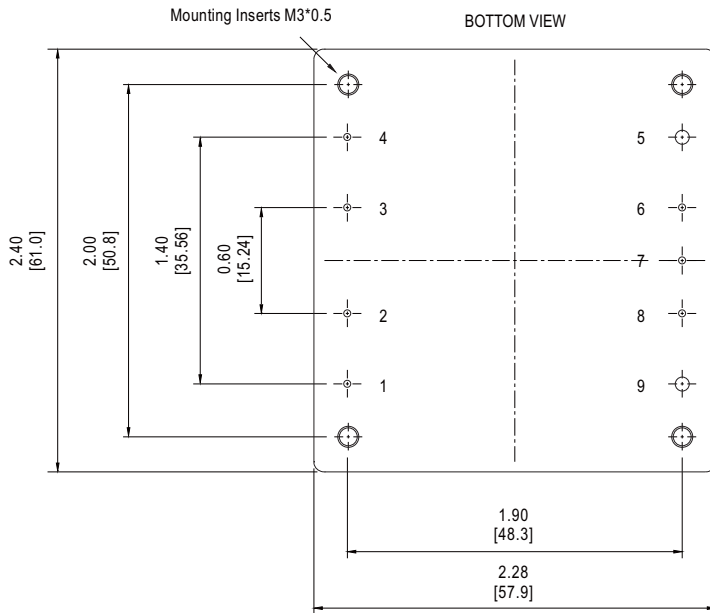

Pin No. Assignment

Pin No.	Assignment	Pin No.	Assignment	Pin No.	Assignment
1	+Vin	4	-Vin	7	Trim
2	R.C.	5	-Vout	8	+R.S.
3	Case	6	-R.S.	9	+Vout

Remote ON/OFF Control

The MHB75 series allow the user to switch the power ON and OFF electronically by their remote ON/OFF feature. The MHB75 series are available with "Positive Logic" (standard) or "Negative Logic" (option).

Logic table

Logic State(pin2)	Positive logic	Negative logic
Logic Low-Switch Closed	Power OFF(<0.8Vdc)	Power ON(<0.8Vdc)
Logic High-Switch Open	Power ON(Open circuit)	Power OFF(Open circuit)

Note: 1.Logic compatibility : R.C.(pin2) ~ -Vin(pin4).

2.Suffix "N" to the model number with Negative logic remote ON/OFF.

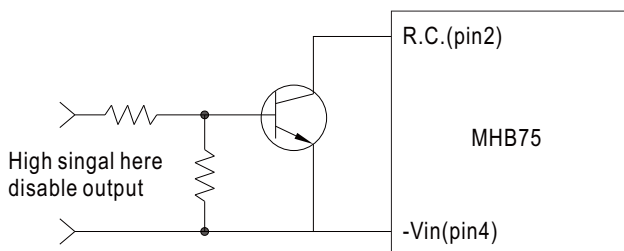

Example control circuit(positive logic)

■ External Output Trimming

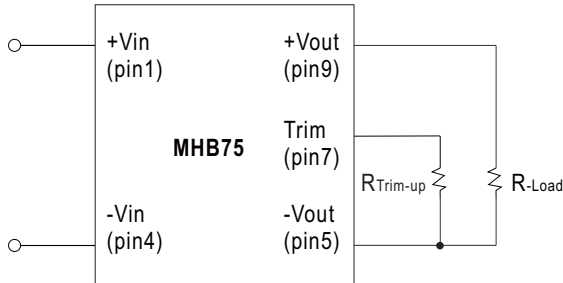

Figure 1 : Trim-up voltage setup

The value of $R_{Trim-up}$ defined as:

$$R_{Trim-up} = \frac{(R1-R2 \times (V_o - V_{o, nom}))}{(V_o - V_{o, nom})} (K\Omega)$$

Where: $R_{Trim-up}$ is the external resistor in Kohm.

$V_{o, nom}$ is the nominal output voltage.

V_o is the desired output voltage.

$R1$ and $R2$ are inside the unit and list in Table 1

Output Voltage(V)	R1 (Kohm)	R2 (Kohm)
5V	5.8	8.25
12V	19.656	13.304
24V	42.215	16.923

Table 1

For example, to Trim-up the output voltage of 5.0V model (MHB75-48S05)

by 8% to 5.4V, $R_{Trim-up}$ is calculated

as follows:

$$V_o - V_{o, nom} = 5.4 - 5.0 = 0.4V$$

$$R1 = 5.8 \text{ Kohm}$$

$$R2 = 8.25 \text{ Kohm}$$

$$R_{Trim-up} = \frac{5.8 - 8.25 \times 0.4}{0.4} = 6.25 (K\Omega)$$

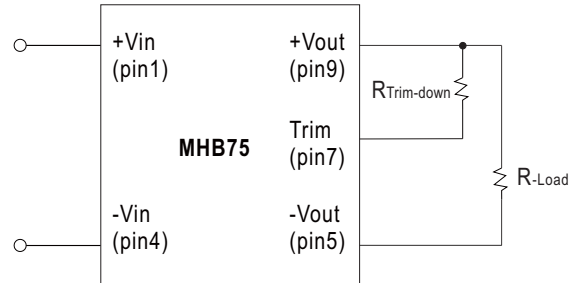

Figure 2 : Trim-down voltage setup

The value of $R_{Trim-down}$ defined as:

$$R_{Trim-down} = \frac{(R1 - R2 \times (V_o, nom - V_o))}{(V_o, nom - V_o)} (K\Omega)$$

Where: $R_{Trim-down}$ is the external resistor in Kohm.

$V_{o, nom}$ is the nominal output voltage.

V_o is the desired output voltage.

$R1$ and $R2$ are inside the unit and list in Table 2.

Output Voltage(V)	R1 (Kohm)	R2 (Kohm)
5V	5.8	10.57
12V	86.45	60.1
24V	430	130

Table 2

For example, to Trim-down the output

Voltage of 5.0V model (MHB75-48S05)

by 8% to 4.6V, $R_{Trim-down}$ is

calculated as follows :

$$V_{o, nom} - V_o = 5.0 - 4.6 = 0.4 V$$

$$R1 = 5.8 \text{ Kohm}$$

$$R2 = 10.57 \text{ Kohm}$$

$$R_{Trim-down} = \frac{5.8 - 10.57 \times 0.4}{0.4} = 3.93 (K\Omega)$$

Thermal Curve

The operating case temperature range of MHB-75 series is -40°C to +100°C. When operate the MHB-75 series, proper de-rating or cooling is needed.

The maximum case temperature under any operating condition should not be exceed 100°C. The following curve is the de-rating curve of MHB-75 series without heat sink.

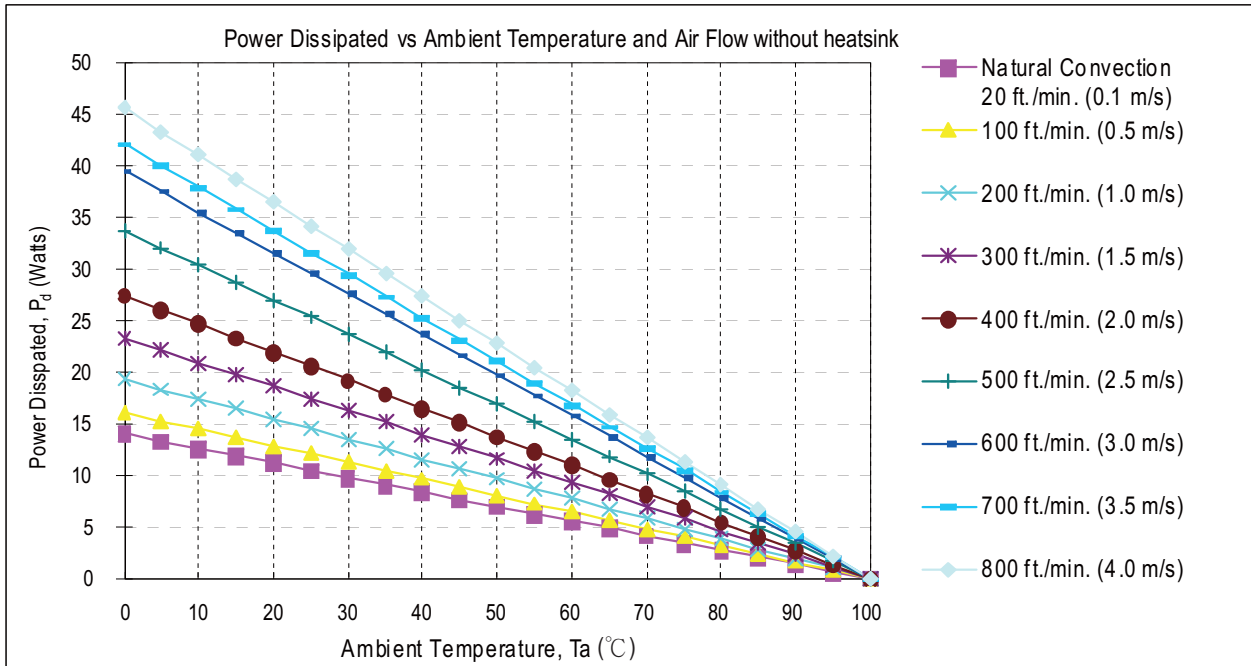

Air Flow Rate	Typical Rca	Air Flow Rate	Typical Rca
Natural convection 20ft./min. (0.1m/s)	7.12°C/W	500 ft./min. (2.5m/s)	2.96°C/W
100 ft./min. (0.5m/s)	6.21°C/W	600 ft./min. (3.0m/s)	2.53°C/W
200 ft./min. (1.0m/s)	5.17°C/W	700 ft./min. (3.5m/s)	2.37°C/W
300 ft./min. (1.5m/s)	4.29°C/W	800 ft./min. (4.0m/s)	2.19°C/W
400 ft./min. (2.0m/s)	3.64°C/W		

Rca : Thermal resistance from case to ambience

Example:

What is the minimum airflow necessary for a MHB75-48S12 operates at nominal line, an output current of 6.25A, and a maximum ambient temperature of 40°C?

Solution:

Given: Vin=48Vdc, Vo=12Vdc, Io=6.25A, η (unit efficiency)=89%

Determine Power dissipation (Pd):

$$P_d = P_i - P_o = P_o(1 - \eta) / \eta$$

$$P_d = 12 \times 6.25 \times (1 - 0.89) / 0.89 = 9.27 \text{ Watts}$$

Determine airflow:

Given: Pd=9.27W and Ta=40°C

Check Thermal Curve above:

minimum airflow= 100 ft./min.

Verifying: The maximum temperature rise $\Delta T = P_d \times R_{ca} = 9.27 \times 6.21 = 57.57^\circ\text{C}$

The maximum case temperature $T_c = T_a + \Delta T = 97.57^\circ\text{C} < 100^\circ\text{C}$

Where: The Rca is thermal resistance from case to ambience.

The Ta is ambient temperature and the Tc is case temperature.

■ Case Heat Sink (Optional)

Unit:mm

Model No.: M-C308 (Vertical Fins)



Model No.: M-C091(Horizontal Fins)



Model No.: M-C092 (Horizontal Fins)

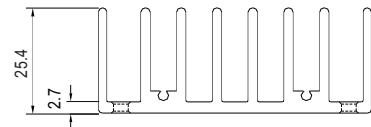
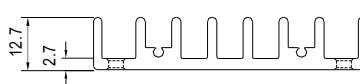
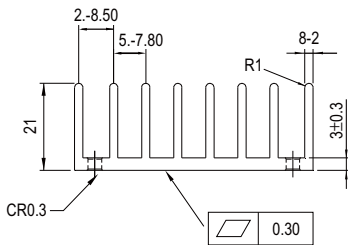
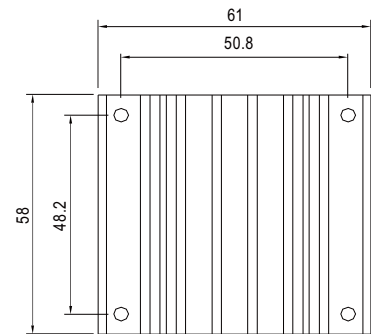
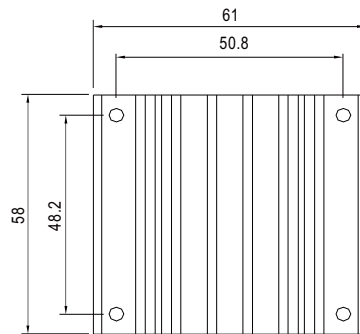
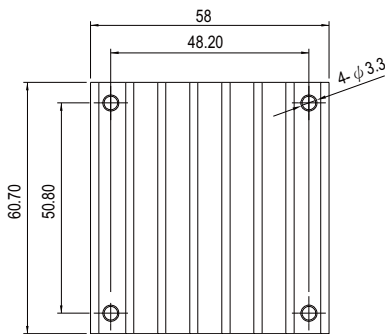

Rca:

- 3.90°C / W (typ.), at natural convection
- 1.74°C / W (typ.), at 100ft./min.(LFM)
- 1.33°C / W (typ.), at 200ft./min.(LFM)
- 1.12°C / W (typ.), at 300ft./min.(LFM)
- 0.97°C / W (typ.), at 400ft./min.(LFM)

Rca:

- 4.70°C / W (typ.), at natural convection
- 2.89°C / W (typ.), at 100ft./min.(LFM)
- 2.30°C / W (typ.), at 200ft./min.(LFM)
- 1.88°C / W (typ.), at 300ft./min.(LFM)
- 1.59°C / W (typ.), at 400ft./min.(LFM)

Rca:

- 3.00°C / W (typ.), at natural convection
- 1.44°C / W (typ.), at 100ft./min.(LFM)
- 1.17°C / W (typ.), at 200ft./min.(LFM)
- 1.04°C / W (typ.), at 300ft./min.(LFM)
- 0.95°C / W (typ.), at 400ft./min.(LFM)

■ Heatsink Assembly

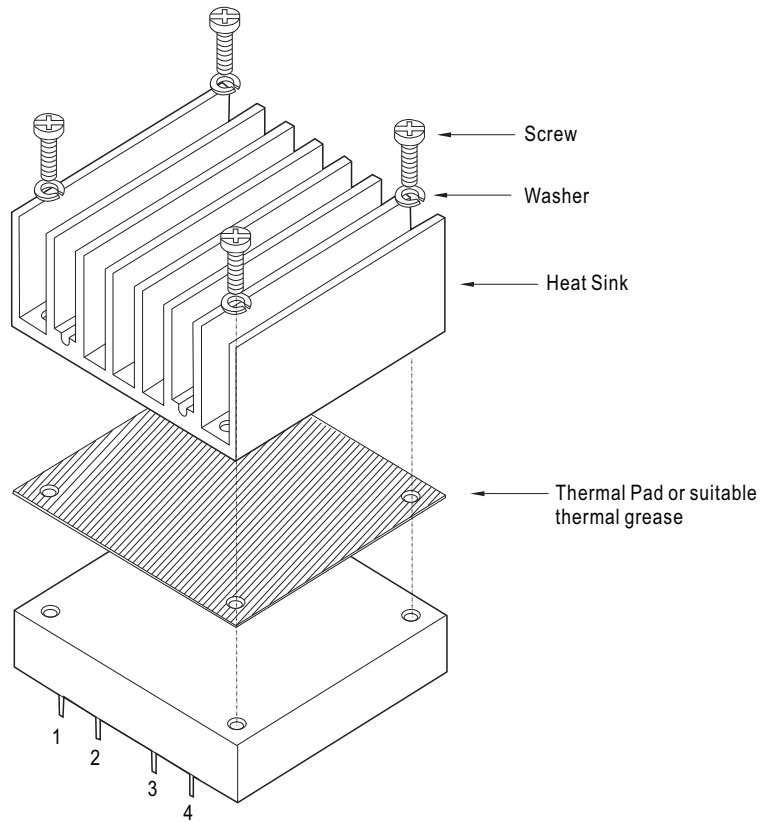

Heat Sink Order No.:
 M-C308
 M-C091
 M-C092
 Thermal Pad: 56.9x60x0.25mm
 Screw: SMP+SW M3x8L

■ EMC Suggestion Circuit

※Required external components to meet EN55022 class A conducted emission are as below:

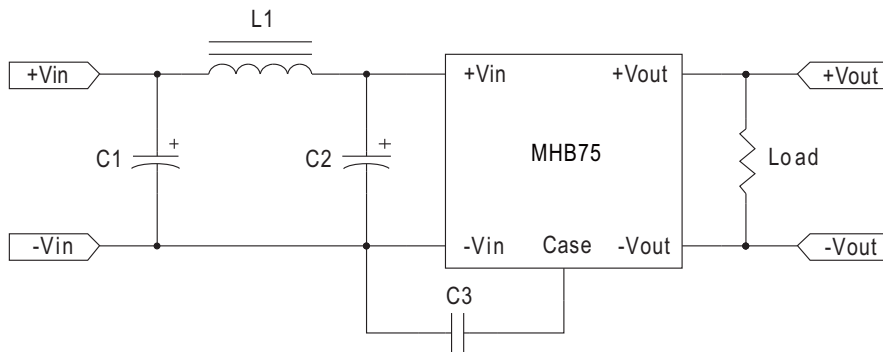

Model No.	C1	C2	C3	L1
MHB75-12S□	100uF/50V ESR<0.33Ω	100uF/50V ESR<0.33Ω	1000pF	1.5uH
MHB75-24S□	100uF/50V ESR<0.33Ω	100uF/50V ESR<0.33Ω	1000pF	1.5uH
MHB75-48S□	33uF/100V ESR<0.46Ω	33uF/100V ESR<0.46Ω	2200pF	8.3uH

□ =05,12,24