



STL20NM20N

N-CHANNEL 200V - 0.088Ω - 20A PowerFLAT™ ULTRA LOW GATE CHARGE MDmesh™ II MOSFET

Table 1: General Features

TYPE	V _{DSS}	R _{DS(on)}	I _D
STL20NM20N	200 V	< 0.105 Ω	20 A

- WORLDWIDE LOWEST GATE CHARGE
- TYPICAL R_{DS(on)} = 0.088Ω
- IMPROVED DIE-TO-FOOTPRINT RATIO
- VERY LOW PROFILE PACKAGE (1mm MAX)
- VERY LOW THERMAL RESISTANCE
- LOW GATE RESISTANCE
- LOW INPUT CAPACITANCE
- HIGH dv/dt and AVALANCHE CAPABILITIES

DESCRIPTION

This 200V MOSFET with a new advanced layout brings all unique advantages of MDmesh technology to lower voltages. The device exhibits worldwide lowest gate charge for any given on-resistance. Its use is therefore ideal as primary switch in isolated DC-DC converters for Telecom and Computer applications. Used in combination with secondary-side low-voltage STripFET™ products, it contributes to reducing losses and boosting efficiency. The new PowerFLAT™ package allows a significant reduction in board space without compromising performance.

APPLICATIONS

The MDmesh™ family is very suitable for increasing power density allowing system miniaturization and higher efficiencies.

Figure 1: Package

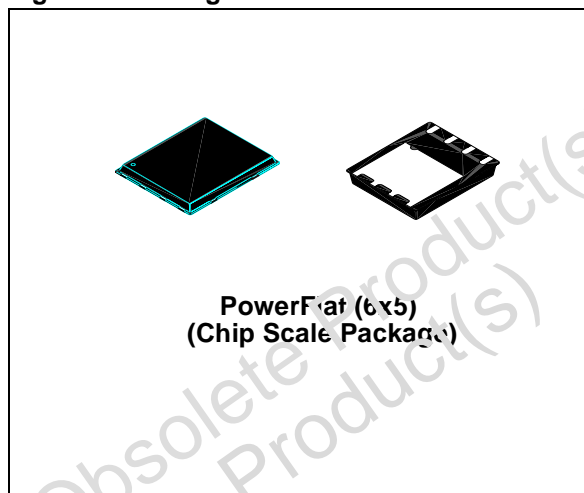

Figure 2: Internal Schematic Diagram

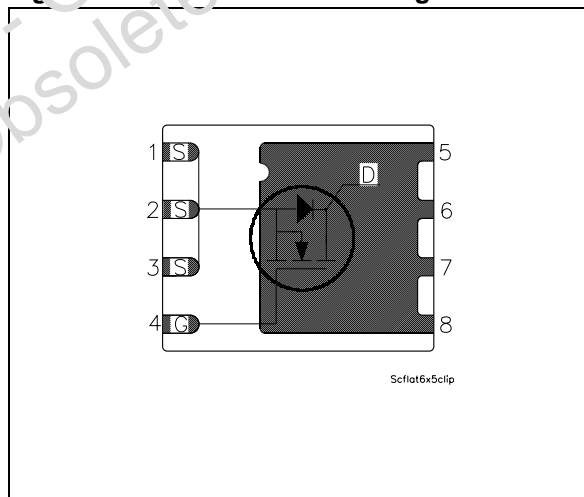

Table 2: Order Codes

SALES TYPE	MARKING	PACKAGE	PACKAGING
STL20NM20N	L20NM20N	PowerFLAT™(6x5)	TAPE & REEL

Table 3: Absolute Maximum ratings

Symbol	Parameter	Value	Unit
V_{DS}	Drain-source Voltage ($V_{GS} = 0$)	200	V
V_{DGR}	Drain-gate Voltage ($R_{GS} = 20 \text{ k}\Omega$)	200	V
V_{GS}	Gate- source Voltage	± 30	V
I_D (1)	Drain Current (continuous) at $T_C = 25^\circ\text{C}$ (Steady State) Drain Current (continuous) at $T_C = 100^\circ\text{C}$	20 12.3	A A
I_{DM} (3)	Drain Current (pulsed)	80	A
P_{TOT} (2)	Total Dissipation at $T_C = 25^\circ\text{C}$ (Steady State)	2.5	W
P_{TOT} (1)	Total Dissipation at $T_C = 25^\circ\text{C}$ (Steady State)	80	W
	Derating Factor (2)	0.02	W/ $^\circ\text{C}$
dv/dt (4)	Peak Diode Recovery voltage slope	10	V/ns

Table 4: Thermal Data

Symbol	Parameter	Typ.	Max.	Unit
R_{thj-c}	Thermal Resistance Junction-case		1.56	$^\circ\text{C}/\text{W}$
$R_{thj-pcb}$ (2)	Thermal Resistance Junction-pcb	35	50	$^\circ\text{C}/\text{W}$
T_j T_{stg}	Max. Operating Junction Temperature Storage Temperature	-55 to 150		$^\circ\text{C}$

Table 5: Avalanche Characteristics

Symbol	Parameter	Max. Value	Unit
I_{AS}	Avalanche Current, Repetitive or Not-Repetitive (pulse width limited by $T_j \text{ max}$)	20	A
E_{AS}	Single Pulse Avalanche Energy (starting $T_j = 25^\circ\text{C}$, $I_D = I_{AR}$, $V_{DL} = 35 \text{ V}$)	380	mJ

ELECTRICAL CHARACTERISTICS ($T_{CASE} = 25^\circ\text{C}$ UNLESS OTHERWISE SPECIFIED)**Table 6: On/Off**

Symbol	Parameter	Test Conditions	Min.	Typ.	Max.	Unit
$V_{(BR)DSS}$	Drain-source Breakdown Voltage	$I_D = 1 \text{ mA}$, $V_{GS} = 0$	200			V
I_{DSS}	Zero Gate Voltage Drain Current ($V_{GS} = 0$)	$V_{DS} = \text{Max Rating}$ $V_{DS} = \text{Max Rating}$, $T_C = 125^\circ\text{C}$			1 10	μA μA
I_{GSS}	Gate-body Leakage Current ($V_{DS} = 0$)	$V_{GS} = \pm 30 \text{ V}$			± 100	nA
$V_{GS(th)}$	Gate Threshold Voltage	$V_{DS} = V_{GS}$, $I_D = 250 \mu\text{A}$	3	4	5	V
$R_{DS(on)}$	Static Drain-source On Resistance	$V_{GS} = 10\text{V}$, $I_D = 10 \text{ A}$		0.088	0.105	Ω

ELECTRICAL CHARACTERISTICS (CONTINUED)

Table 7: Dynamic

Symbol	Parameter	Test Conditions	Min.	Typ.	Max.	Unit
g_{fs} (5)	Forward Transconductance	$V_{DS} = 15\text{ V}$, $I_D = 10\text{ A}$		8		S
C_{iss} C_{oss} C_{rss}	Input Capacitance Output Capacitance Reverse Transfer Capacitance	$V_{DS} = 25\text{ V}$, $f = 1\text{ MHz}$, $V_{GS} = 0$		800 330 130		pF pF pF
$C_{oss\ eq. (*)}$	Equivalent Output Capacitance	$V_{GS} = 0\text{ V}$, $V_{DS} = 0\text{ V to } 160\text{ V}$		225		pF
$t_{d(on)}$ t_r $t_{d(off)}$ t_f	Turn-on Delay Time Rise Time Turn-off Delay Time Fall Time	$V_{DD} = 100\text{ V}$, $I_D = 10\text{ A}$ $R_G = 4.7\Omega$, $V_{GS} = 10\text{ V}$ (see Figure 16)		40 15 40 11		ns ns ns ns
Q_g Q_{gs} Q_{gd}	Total Gate Charge Gate-Source Charge Gate-Drain Charge	$V_{DD} = 160\text{ V}$, $I_D = 20\text{ A}$, $V_{GS} = 10\text{ V}$ (see Figure 19)		32 6 25	50	nC nC nC

(*) $C_{oss\ eq.}$ is defined as a constant equivalent capacitance giving the same charging time as C_{oss} when V_{DS} increases from 0 to 80% V_{DSS}

Table 8: Source Drain Diode

Symbol	Parameter	Test Conditions	Min.	Typ.	Max.	Unit
I_{SD}	Source-drain Current				20	A
I_{SDM} (3)	Source-drain Current (pulsed)				80	A
V_{SD} (5)	Forward On Voltage	$I_{SD} = 20\text{ A}$, $V_{GS} = 0$			1.3	V
t_{rr} Q_{rr} I_{RRM}	Reverse Recovery Time Reverse Recovery Charge Reverse Recovery Current	$I_{SD} = 20\text{ A}$, $di/dt = 100\text{ A}/\mu\text{s}$, $V_{DD} = 100\text{ V}$, $T_j = 25^\circ\text{C}$ (see Figure 17)		160 960 128		ns nC A
t_{rr} Q_{rr} I_{RRM}	Reverse Recovery Time Reverse Recovery Charge Reverse Recovery Current	$I_{SD} = 20\text{ A}$, $di/dt = 100\text{ A}/\mu\text{s}$, $V_{DD} = 100\text{ V}$, $T_j = 150^\circ\text{C}$ (see Figure 17)		225 1642 15		ns nC A

- Note: 1. The value is rated according to R_{thj-c} .
 2. When Mounted on FR-4 Board of 1inch², 2 oz Cu
 3. Pulse width limited by safe operating area
 4. $I_{SD} \leq 20\text{ A}$, $di/dt \leq 400\text{ A}/\mu\text{s}$, $V_{DD} \leq V_{(BR)DSS}$
 5. Pulsed: Pulse duration = 300 μs , duty cycle 1.5 %

Figure 3: Safe Operating Area

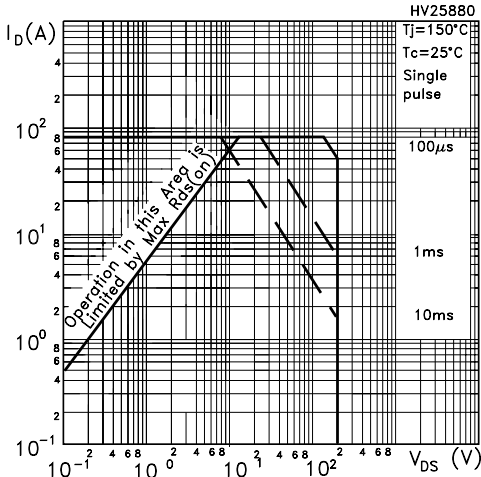

Figure 4: Output Characteristics

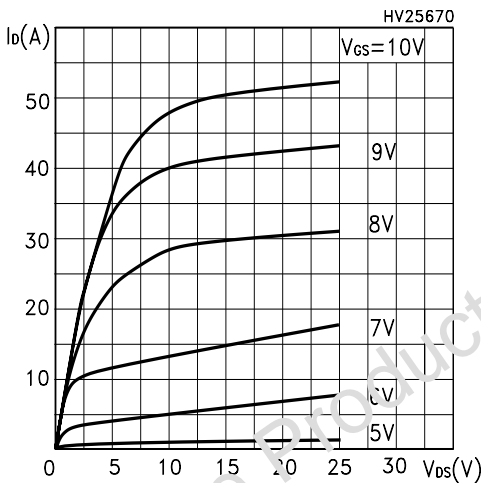

Figure 5: Transconductance

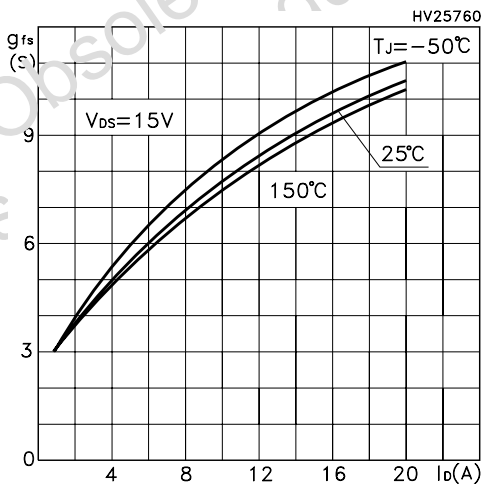

Figure 6: Thermal Impedance

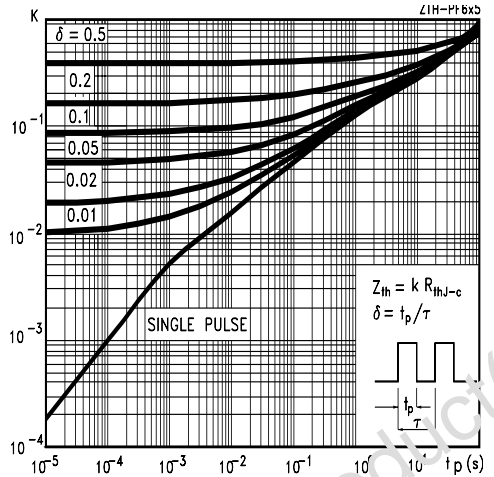

Figure 7: Transfer Characteristics

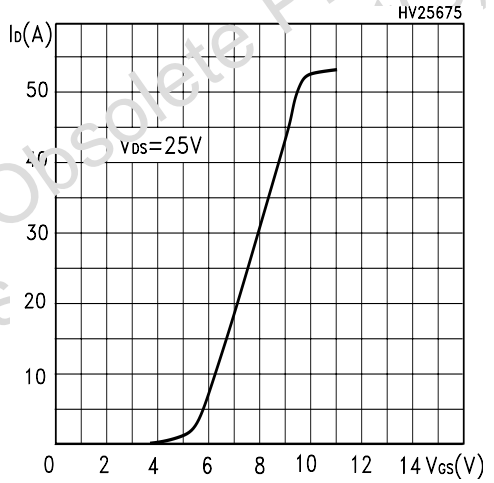

Figure 8: Static Drain-source On Resistance

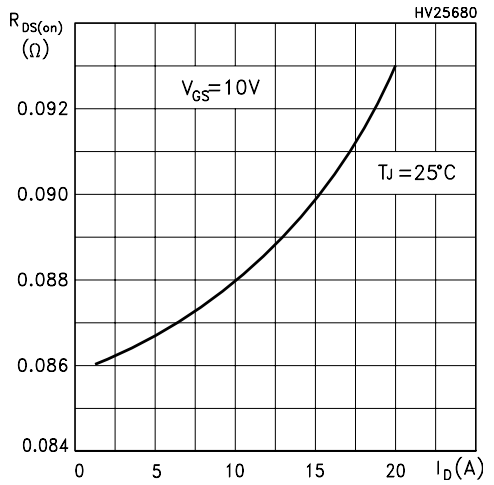

Figure 9: Gate Charge vs Gate-source Voltage

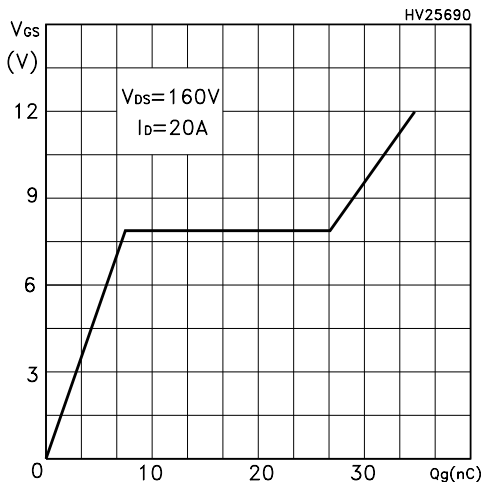

Figure 10: Normalized Gate Threshold Voltage vs Temperature

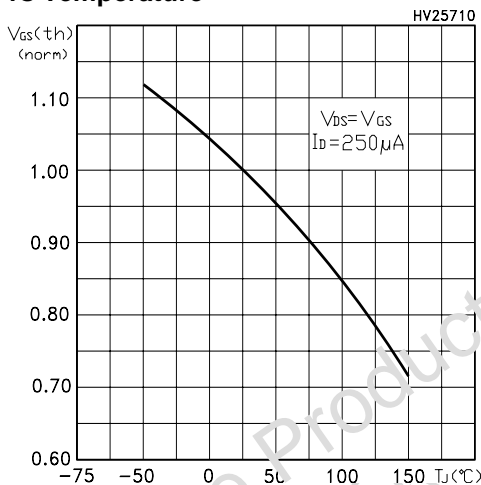

Figure 11: Source-Drain Diode Forward Characteristics

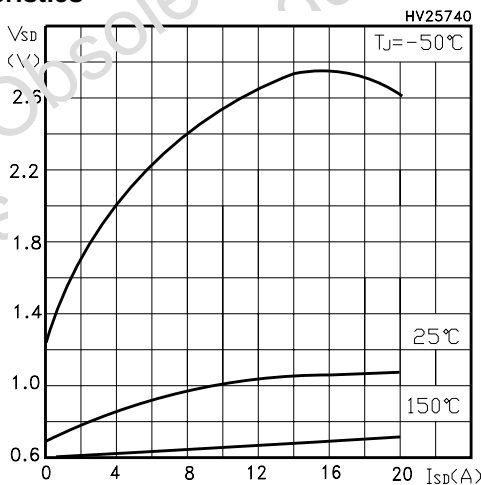

Figure 12: Capacitance Variations

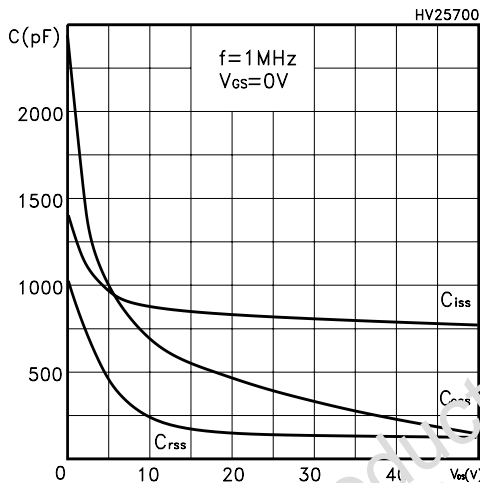

Figure 13: Normalized On Resistance vs Temperature

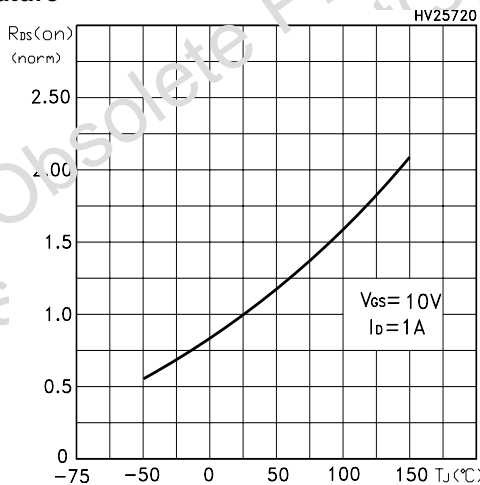

Figure 14: Normalized BVdss vs Temperature

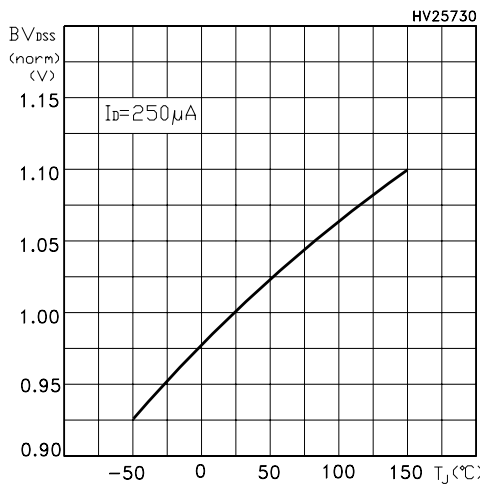

Figure 15: Unclamped Inductive Load Test Circuit

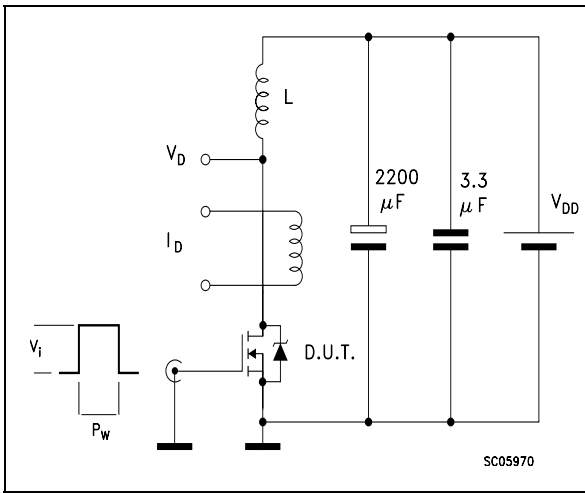

Figure 16: Switching Times Test Circuit For Resistive Load

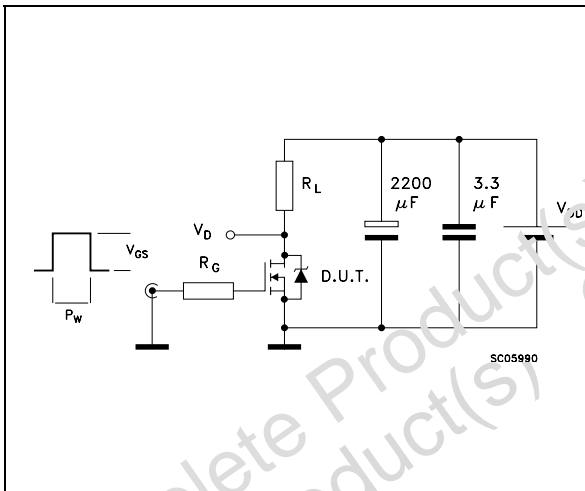

Figure 17: Test Circuit For Inductive Load Switching and Diode Recovery Times

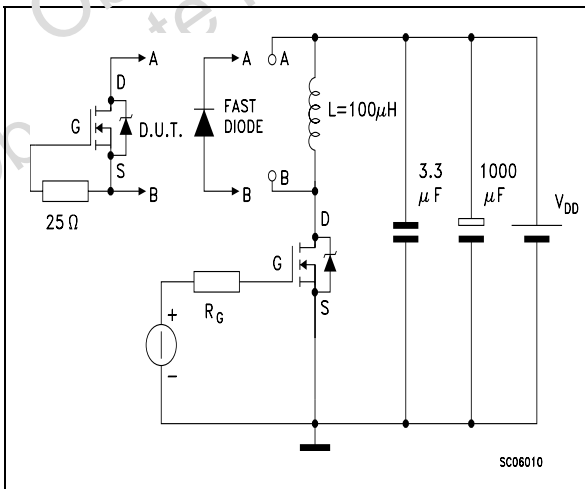

Figure 18: Unclamped Inductive Waferform

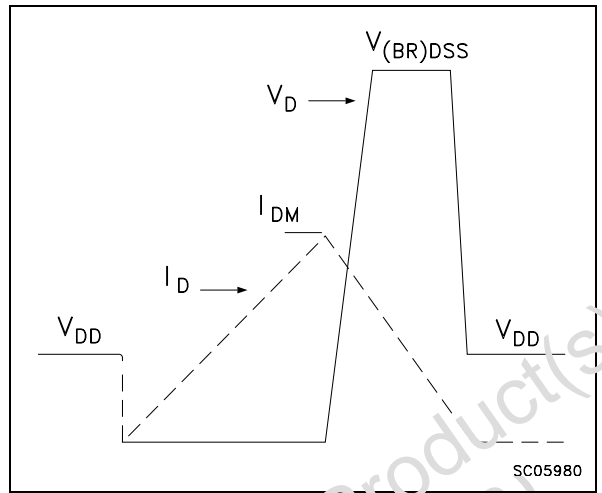
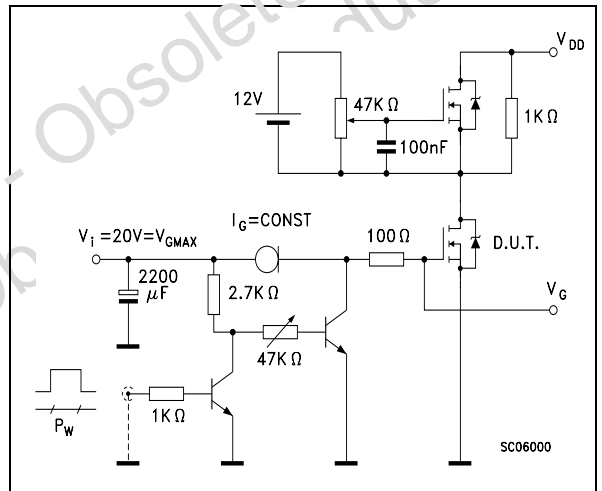

Figure 19: Gate Charge Test Circuit



In order to meet environmental requirements, ST offers these devices in ECOPACK® packages. These packages have a Lead-free second level interconnect . The category of second level interconnect is marked on the package and on the inner box label, in compliance with JEDEC Standard JESD97. The maximum ratings related to soldering conditions are also marked on the inner box label. ECOPACK is an ST trademark. ECOPACK specifications are available at: www.st.com

Obsolete Product(s) - Obsolete Product(s)
Obsolete Product(s) - Obsolete Product(s)

PowerFLAT™ (6x5) MECHANICAL DATA

DIM.	mm.			inch		
	MIN.	TYP	MAX.	MIN.	TYP.	MAX.
A	0.80	0.83	0.93	0.031	0.032	0.036
A1		0.02	0.05		0.0007	0.0019
A3		0.20			0.007	
b	0.35	0.40	0.47	0.013	0.015	0.018
D		5.00			0.196	
D1		4.75			0.187	
D2	4.15	4.20	4.25	0.163	0.165	0.167
E		6.00			0.236	
E1		5.75			0.226	
E2	3.43	3.48	3.53	0.135	0.137	0.139
E4	2.58	2.63	2.68		0.103	0.105
e		1.27			0.050	
L	0.70	0.80	0.90	0.027	0.031	0.035

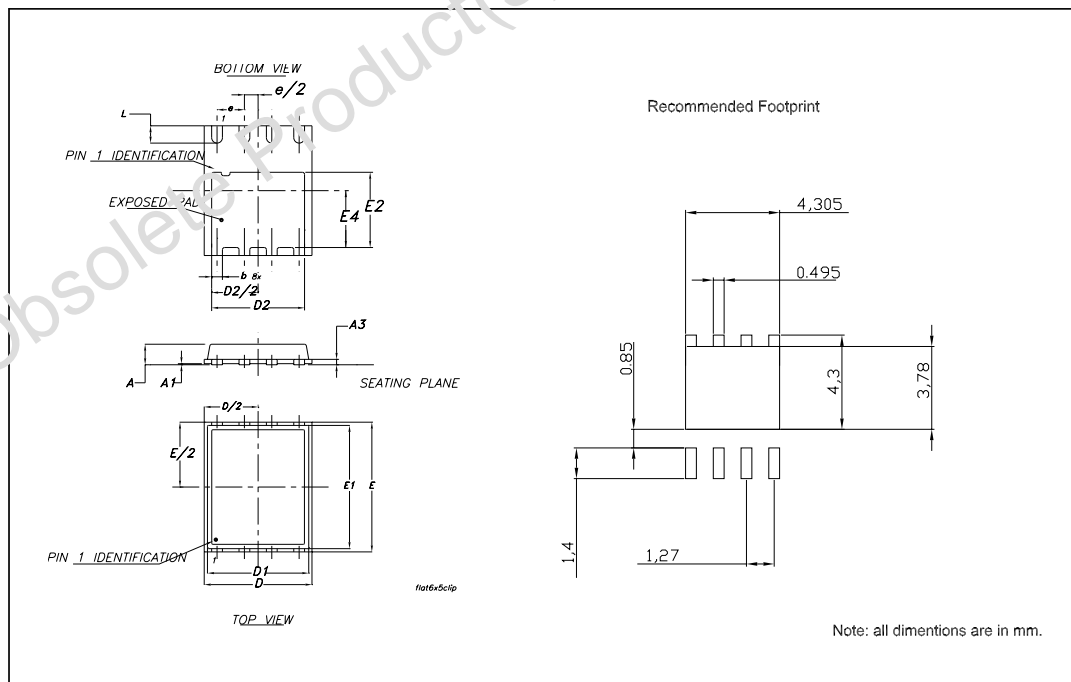

Table 9: Revision History

Date	Revision	Description of Changes
16-Feb-2005	2	New stylesheet Some Values changed on table 6 and 8
09-Jun-2005	3	Inserted curves
20-Jun-2005	4	Updated mechanical data
04-Nov-2005	5	Modified value on table 8, inserted ecopack indication
09-Jan-2006	6	New footprint

Obsolete Product(s) - Obsolete Product(s)
Obsolete Product(s) - Obsolete Product(s)

Information furnished is believed to be accurate and reliable. However, STMicroelectronics assumes no responsibility for the consequences of use of such information nor for any infringement of patents or other rights of third parties which may result from its use. No license is granted by implication or otherwise under any patent or patent rights of STMicroelectronics. Specifications mentioned in this publication are subject to change without notice. This publication supersedes and replaces all information previously supplied. STMicroelectronics products are not authorized for use as critical components in life support devices or systems without express written approval of STMicroelectronics.

The ST logo is a registered trademark of STMicroelectronics

All other names are the property of their respective owners

© 2005 STMicroelectronics - All Rights Reserved

STMicroelectronics group of companies

Australia - Belgium - Brazil - Canada - China - Czech Republic - Finland - France - Germany - Hong Kong - India - Israel - Italy - Japan - Malaysia - Malta - Morocco - Singapore - Spain - Sweden - Switzerland - United Kingdom - United States of America

www.st.com