

## Ceramic Disc Capacitors Class 1 and 2, 50 V<sub>DC</sub>, General Purpose

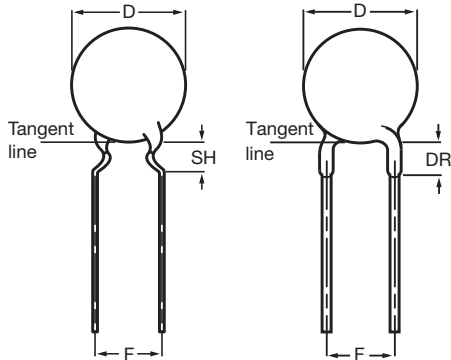

Capacitors with 5 mm (0.20") and 2.5 mm (0.10") lead spacing

QUICK REFERENCE DATA		
DESCRIPTION	CLASS 1 (NP0, SL0)	CLASS 2 (Y5P, Z5U, Y5V, Z5V)
Voltage (V <sub>DC</sub> )	50	
Min. Capacitance (pF)	1	150
Max. Capacitance (pF)	100	47 000
Mounting	Through hole	

### MARKING

Marking indicates capacitance value and tolerance in accordance with "EIA 198"

### OPERATING TEMPERATURE RANGE

Class 1, - 55 °C to + 125 °C

Class 2, - 30 °C to + 85 °C

### TEMPERATURE COEFFICIENT Y5R (2C4) - 30 °C TO + 85 °C

Class 1, NP0; SL0

Class 2, Y5P; Z5U; Y5V; Z5V

### SECTIONAL SPECIFICATIONS

Class 1, IEC 60 384-8,

Class 2, IEC 60 384-9,

EIA 198

### CLIMATIC CATEGORY

Class 1, - 55 °C to + 125 °C

Class 2, - 30 °C to + 85 °C

### Note

- The capacitors meet the essential requirements of "IEC 60384-9 and EIA 198". Unless stated otherwise all electrical values apply at an ambient temperature of 25 °C ± 3 °C, at normal atmospheric conditions

### FEATURES

- Low losses
- High stability
- High capacitance in small size
- Kinked (preferred) or straight leads
- Compliant to RoHS directive 2002/95/EC



**RoHS**  
COMPLIANT

### APPLICATIONS

- Bypassing
- Coupling
- Resonant circuit

### DESIGN

The capacitors consist of a ceramic disc both sides of which are silver-plated. Connection leads are made of tinned copper having a diameter of 0.6 mm.

The capacitors have inward kinked leads with a spacing of 5 mm (0.20") and straight leads with 2.5 mm (0.10"), lead length from 4 mm to 30 mm.

Encapsulation is made of phenolic resin.

### CAPACITANCE RANGE

Class 1, at 1 MHz, 1.2 V<sub>RMS</sub>; 1.0 pF to 100 pF

1 kHz, 1 V<sub>RMS</sub> ± 0.2 V<sub>RMS</sub> for capacitance values higher than 1000 pF

Class 2, at 1 kHz, 1 V<sub>RMS</sub> ± 0.2 V<sub>RMS</sub> 150 pF to 47 000 pF

### RATED DC VOLTAGE

50 V

### DIELECTRIC STRENGTH

250 % of rated voltage

### INSULATION RESISTANCE AT 500 V<sub>DC</sub>

≥ 10 000 MΩ

### TOLERANCE ON CAPACITANCE

± 5 %; ± 10 %; ± 20 %; + 80 %/- 20 %

### DISSIPATION FACTOR

Class 1, C ≤ 30 pF ≤ 20 × (10/C + 0.7) × 10<sup>-4</sup> maximum

Class 1, C > 30 pF ≤ 0.2 %

Class 2, ≤ 3.0 %



Ceramic Disc Capacitors  
Class 1 and 2, 50 V<sub>DC</sub>, General Purpose

Vishay BCcomponents

<b>ORDERING INFORMATION, CLASS 1, 50 V<sub>DC</sub>, KINKED</b>					
C (pF)	TOL. (%)	D <sub>MAX.</sub> (mm)	SH/DR <sub>MAX.</sub> <sup>(1)</sup> (mm)	CLEAR TEXT CODE	
				13 <sup>TH</sup> DIGIT: T = REEL; U = AMMO; 3 = BULK	
<b>CLASS 1 NPO</b>					
1.0	± 0.25 pF	5.0	5.0	4.0	D109C20C0KF6.J5R
			2.5	1.5	D109C20C0KF6.L2R
1.5			5.0	4.0	D159C20C0KF6.J5R
			2.5	1.5	D159C20C0KF6.L2R
2.2			5.0	4.0	D229C20C0JF6.J5R
			2.5	1.5	D229C20C0JF6.L2R
3.3	± 0.5 pF		5.0	4.0	D339C20C0JF6.J5R
			2.5	1.5	D339C20C0JF6.L2R
4.7			5.0	4.0	D479C20C0HF6.J5R
			2.5	1.5	D479C20C0HF6.L2R
6.8			5.0	4.0	D689D20C0HF6.J5R
			2.5	1.5	D689D20C0HF6.L2R
10	± 5.0		5.0	4.0	D100J20C0GF6.J5R
			2.5	1.5	D100J20C0GF6.L2R
12			5.0	4.0	D120J20C0GF6.J5R
			2.5	1.5	D120J20C0GF6.L2R
15			5.0	4.0	D150J20C0GF6.J5R
			2.5	1.5	D150J20C0GF6.L2R
18			5.0	4.0	D180J20C0GF6.J5R
			2.5	1.5	D180J20C0GF6.L2R
22			5.0	4.0	D220J20C0GF6.J5R
			2.5	1.5	D220J20C0GF6.L2R
27			5.0	4.0	D270J20C0GF6.J5R
			2.5	1.5	D270J20C0GF6.L2R
33		5.0	4.0	D330J20C0GF6.J5R	
		2.5	1.5	D330J20C0GF6.L2R	
39		5.0	4.0	D390J20C0GF6.J5R	
		2.5	1.5	D390J20C0GF6.L2R	
47		5.0	4.0	D470J20C0GF6.J5R	
		2.5	1.5	D470J20C0GF6.L2R	
<b>CLASS 1 SLO</b>					
56	± 5.0	5.0	4.0	D560J20SLOF6.J5R	
		2.5	1.5	D560J20SLOF6.L2R	
68		5.0	4.0	D680J20SLOF6.J5R	
		2.5	1.5	D680J20SLOF6.L2R	
82		5.0	4.0	D820J20SLOF6.J5R	
		2.5	1.5	D820J20SLOF6.L2R	
100	5.0	4.0	D101J20SLOF6.J5R		
	2.5	1.5	D101J20SLOF6.L2R		

**Notes**

- (1) SH = seated height; DR = run down
- Maximum thickness 4.0 mm
- Lead style codes refer to lead configurations

ORDERING INFORMATION, CLASS 2, 50 V <sub>DC</sub> , KINKED					
C (pF)	TOL. (%)	D <sub>MAX.</sub> (mm)	SH/DR <sub>MAX.</sub> <sup>(1)</sup> (mm)	CLEAR TEXT CODE	
				13 <sup>TH</sup> DIGIT: T = REEL; U = AMMO; 3 = BULK	
<b>CLASS 2 Y5P</b>					
150	± 10	5	5.0	4.0	D151K20Y5PF6.J5R
			2.5	1.5	D151K20Y5PF6.L2R
180			5.0	4.0	D181K20Y5PF6.J5R
			2.5	1.5	D181K20Y5PF6.L2R
220			5.0	4.0	D221K20Y5PF6.J5R
			2.5	1.5	D221K20Y5PF6.L2R
330			5.0	4.0	D331K20Y5PF6.J5R
			2.5	1.5	D331K20Y5PF6.L2R
470			5.0	4.0	D471K20Y5PF6.J5R
			2.5	1.5	D471K20Y5PF6.L2R
680		5.0	4.0	D681K20Y5PF6.J5R	
		2.5	1.5	D681K20Y5PF6.L2R	
1000		5.0	4.0	D102K20Y5PF6.J5R	
		2.5	1.5	D102K20Y5PF6.L2R	
1500		5.0	4.0	D152K20Y5PF6.J5R	
		2.5	1.5	D152K20Y5PF6.L2R	
1800		6.5	5.0	4.0	D182K25Y5PF6.J5R
			2.5	1.5	D182K25Y5PF6.L2R
2200			5.0	4.0	D222K25Y5PF6.J5R
			2.5	1.5	D222K25Y5PF6.L2R
3300	5.0		4.0	D332K25Y5PF6.J5R	
	2.5	1.5	D332K25Y5PF6.L2R		
4700	7.5	5.0	4.0	D472K29Y5PF6.J5R	
		2.5	1.5	D472K29Y5PF6.L2R	
6800	8.5	5.0	4.0	D682K33Y5PF6.J5R	
		2.5	1.5	D682K33Y5PF6.L2R	
10 000	10	5.0	4.0	D103K39Y5PF6.J5R	
		2.5	1.5	D103K39Y5PF6.L2R	

**Notes**

(1) SH = seated height; DR = run down

- Maximum thickness 4.0 mm
- Lead style codes refer to lead configurations

ORDERING INFORMATION, CLASS 2, 50 V <sub>DC</sub> , KINKED AND STRAIGHT					
C (pF)	TOL. (%)	D <sub>MAX.</sub> (mm)	SH/DR <sub>MAX.</sub> <sup>(1)</sup> (mm)	CLEAR TEXT CODE	
				13 <sup>TH</sup> DIGIT: T = REEL; U = AMMO; 3 = BULK	
<b>CLASS 2 Z5U</b>					
1000	± 20	5	5.0	4.0	D102M20Z5UF6.J5R
			2.5	1.5	D102M20Z5UF6.L2R
1500			5.0	4.0	D152M20Z5UF6.J5R
			2.5	1.5	D152M20Z5UF6.L2R
2200			5.0	4.0	D222M20Z5UF6.J5R
		2.5	1.5	D222M20Z5UF6.L2R	
3300		5.0	4.0	D332M20Z5UF6.J5R	
		2.5	1.5	D332M20Z5UF6.L2R	
4700		5.0	4.0	D472M20Z5UF6.J5R	
		2.5	1.5	D472M20Z5UF6.L2R	
6800	± 20	6.5	5.0	4.0	D682M25Z5UF6.J5R
			2.5	1.5	D682M25Z5UF6.L2R



Ceramic Disc Capacitors  
Class 1 and 2, 50 V<sub>DC</sub>, General Purpose

<b>ORDERING INFORMATION, CLASS 2, 50 V<sub>DC</sub>, KINKED AND STRAIGHT</b>							
C (pF)	TOL. (%)	D <sub>MAX.</sub> (mm)	SH/DR <sub>MAX.</sub> <sup>(1)</sup> (mm)	CLEAR TEXT CODE			
				13 <sup>TH</sup> DIGIT: T = REEL; U = AMMO; 3 = BULK			
<b>CLASS 2 Z5U</b>							
10 000	± 20	7.5	5.0	4.0	D103M29Z5UF6.J5R		
			2.5	1.5	D103M29Z5UF6.L2R		
15 000		8.5	5.0	4.0	D153M33Z5UF6.J5R		
			2.5	1.5	D153M33Z5UF6.L2R		
22 000		10	5.0	4.0	D223M39Z5UF6.J5R		
			2.5	1.5	D223M39Z5UF6.L2R		
<b>CLASS 2 Y5V</b>							
1000	+ 80/-20	5	5.0	4.0	D102Z20Y5VF6.J5R		
			2.5	1.5	D102Z20Y5VF6.L2R		
1500			5.0	4.0	D152Z20Y5VF6.J5R		
			2.5	1.5	D152Z20Y5VF6.L2R		
2200			5.0	4.0	D222Z20Y5VF6.J5R		
			2.5	1.5	D222Z20Y5VF6.L2R		
3300		6.5	5.0	4.0	D332Z20Y5VF6.J5R		
			2.5	1.5	D332Z20Y5VF6.L2R		
4700			5.0	4.0	D472Z20Y5VF6.J5R		
			2.5	1.5	D472Z20Y5VF6.L2R		
6800			5.0	4.0	D682Z25Y5VF6.J5R		
			2.5	1.5	D682Z25Y5VF6.L2R		
10 000		7.5	5.0	4.0	D103Z29Y5VF6.J5R		
			2.5	1.5	D103Z29Y5VF6.L2R		
15 000			8.5	5.0	4.0	D153Z33Y5VF6.J5R	
				2.5	1.5	D153Z33Y5VF6.L2R	
22 000				10	5.0	4.0	D223Z39Y5VF6.J5R
					2.5	1.5	D223Z39Y5VF6.L2R
<b>CLASS 2 Z5V</b>							
4700	+ 80/-20	5			5.0	4.0	D472Z20Z5VF6.J5R
			2.5		1.5	D472Z20Z5VF6.L2R	
10 000		6.5	5.0		4.0	D103Z25Z5VF6.J5R	
			2.5	1.5	D103Z25Z5VF6.L2R		
22 000			7.5	5.0	4.0	D223Z29Z5VF6.J5R	
				2.5	1.5	D223Z29Z5VF6.L2R	
47 000	10			5.0	4.0	D473Z39Z5VF6.J5R	
				2.5	1.5	D473Z39Z5VF6.L2R	

**Notes**

- <sup>(1)</sup> SH = seated height; DR = run down
- Maximum thickness 4.0 mm
- Lead style codes refer to lead configurations

<b>PACKAGING</b>				
D <sub>MAX.</sub>	SIZE CODE	PACKAGING QUANTITIES		
		BULK	REEL	AMMO
5.0 (0.20")	20	1000	2500	2000
6.5 (0.25")	25			
7.5 (0.29")	29			
8.5 (0.33")	33			
10.0 (0.39")	39			
11.0 (0.43")	43			

**Note**

- The capacitors are supplied in bulk packaging (cardboard boxes), in tape on reel or in ammpack

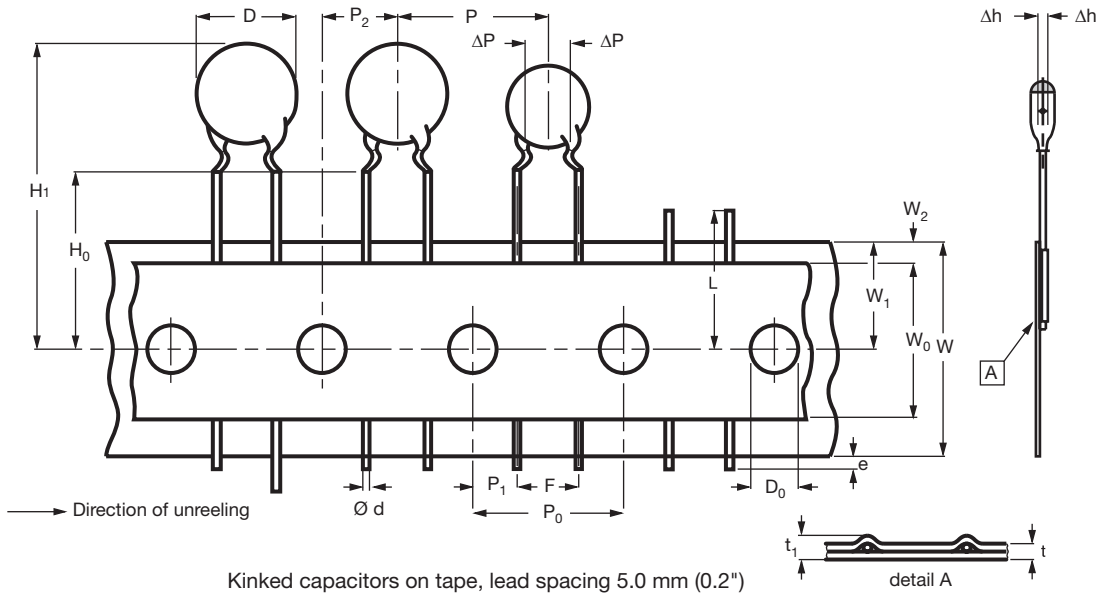

DIMENSIONS OF TAPE			
SYMBOL	PARAMETER	DIMENSIONS (mm)	
		FEED-HOLE PITCH P <sub>0</sub> = 12.7 NOMINAL	FEED-HOLE PITCH P <sub>0</sub> = 15.0 TOLERANCE
D	Body diameter	11.0 maximum	-
d	Lead diameter	0.6	± 0.05
P	Pitch between capacitors	12.7	± 1.0
P <sub>0</sub> <sup>(1)</sup>	Feed-hole pitch	12.7	± 0.3
ΔP	Plane deviation	1.0 maximum	-
P <sub>1</sub> <sup>(2)</sup>	Feed-hole center to lead center	3.85	± 0.7
P <sub>2</sub> <sup>(2)</sup>	Feed-hole center to component center	6.35	± 1.3
F	Lead spacing	5.0	0.6/- 0.4
Δh	Component alignment	0	± 1.0
W	Tape width	18.0	+ 1.0/- 0.5
W <sub>0</sub>	Hold-down tape width	5.0 minimum	-
W <sub>1</sub>	Hole position	9.0	+ 0.75/- 0.5
W <sub>2</sub>	Hold-down tape margin	3.0 maximum	-
H <sub>0</sub>	Height to seating plane	16.0	± 0.5
H <sub>1</sub>	Maximum component height	32.0	-
e	Lead end protrusion	1.0 maximum	-
L	Maximum length of snapped lead	11.0	-
D <sub>0</sub>	Feed-hole diameter	4.0	± 0.2
t	Total tape thickness	0.9 maximum	-
t <sub>1</sub>	Maximum thickness of tape and wires	1.5 maximum	-

**Notes**

(1) Cumulative pitch error: ± ≤ 1 mm/20 pitches

(2) Obliquity maximum 3°



**REEL AND TAPE DATA** in millimeters

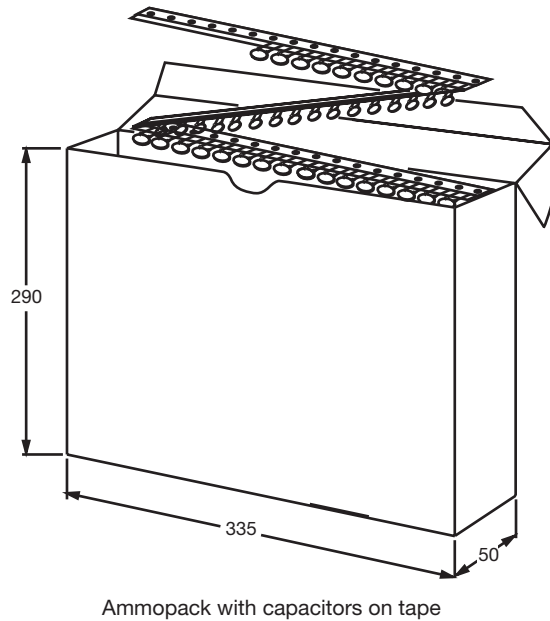
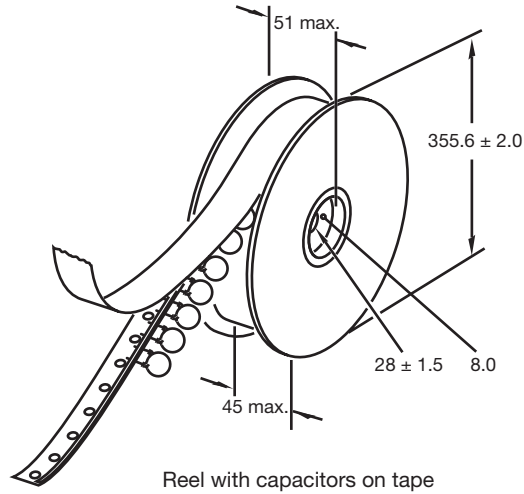



## Disclaimer

ALL PRODUCT, PRODUCT SPECIFICATIONS AND DATA ARE SUBJECT TO CHANGE WITHOUT NOTICE TO IMPROVE RELIABILITY, FUNCTION OR DESIGN OR OTHERWISE.

Vishay Intertechnology, Inc., its affiliates, agents, and employees, and all persons acting on its or their behalf (collectively, "Vishay"), disclaim any and all liability for any errors, inaccuracies or incompleteness contained in any datasheet or in any other disclosure relating to any product.

Vishay makes no warranty, representation or guarantee regarding the suitability of the products for any particular purpose or the continuing production of any product. To the maximum extent permitted by applicable law, Vishay disclaims (i) any and all liability arising out of the application or use of any product, (ii) any and all liability, including without limitation special, consequential or incidental damages, and (iii) any and all implied warranties, including warranties of fitness for particular purpose, non-infringement and merchantability.

Statements regarding the suitability of products for certain types of applications are based on Vishay's knowledge of typical requirements that are often placed on Vishay products in generic applications. Such statements are not binding statements about the suitability of products for a particular application. It is the customer's responsibility to validate that a particular product with the properties described in the product specification is suitable for use in a particular application. Parameters provided in datasheets and/or specifications may vary in different applications and performance may vary over time. All operating parameters, including typical parameters, must be validated for each customer application by the customer's technical experts. Product specifications do not expand or otherwise modify Vishay's terms and conditions of purchase, including but not limited to the warranty expressed therein.

Except as expressly indicated in writing, Vishay products are not designed for use in medical, life-saving, or life-sustaining applications or for any other application in which the failure of the Vishay product could result in personal injury or death. Customers using or selling Vishay products not expressly indicated for use in such applications do so at their own risk. Please contact authorized Vishay personnel to obtain written terms and conditions regarding products designed for such applications.

No license, express or implied, by estoppel or otherwise, to any intellectual property rights is granted by this document or by any conduct of Vishay. Product names and markings noted herein may be trademarks of their respective owners.

## Material Category Policy

**Vishay Intertechnology, Inc. hereby certifies that all its products that are identified as RoHS-Compliant fulfill the definitions and restrictions defined under Directive 2011/65/EU of The European Parliament and of the Council of June 8, 2011 on the restriction of the use of certain hazardous substances in electrical and electronic equipment (EEE) - recast, unless otherwise specified as non-compliant.**

**Please note that some Vishay documentation may still make reference to RoHS Directive 2002/95/EC. We confirm that all the products identified as being compliant to Directive 2002/95/EC conform to Directive 2011/65/EU.**

**Vishay Intertechnology, Inc. hereby certifies that all its products that are identified as Halogen-Free follow Halogen-Free requirements as per JEDEC JS709A standards. Please note that some Vishay documentation may still make reference to the IEC 61249-2-21 definition. We confirm that all the products identified as being compliant to IEC 61249-2-21 conform to JEDEC JS709A standards.**