

Low voltage 16-bit constant current LED sink driver with balanced output rise/fall time

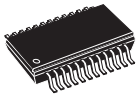

QSOP-24

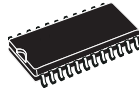

SO-24

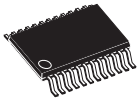

TSSOP24

 TSSOP24
(exposed pad)

Features

- Low voltage power supply down to 3 V
- 16 constant current output channels
- Adjustable output current through external resistor
- Serial data IN/parallel data OUT
- Can be driven by a 3.3 V microcontroller
- Output current: 5 - 100 mA
- Max clock frequency 30 MHz
- ESD protection 2.5 kV HBM, 200 V MM

Description

The **STP16CPC05** is a monolithic, low voltage, low current power 16-bit shift register designed for LED panel displays. The **STP16CPC05** contains a 16-bit serial-in, parallel-out shift register that feeds a 16-bit, D-type storage register. In the output stage, sixteen regulated current sources provide from 5 mA to 100 mA constant current to drive the LEDs. The **STP16CPC05**'s output stage is designed to optimize the turn-on and turn-off time, typically 100 nS. The balanced turning ON/OFF improves the system performances reducing the bypass capacitance in applications where parasitic inductance generate ringing or noise in the system. The LEDs' brightness can be controlled by using an external resistor to adjust the **STP16CPC05** output current. The **STP16CPC05** guarantees a 20 V output driving capability, allowing users to connect more LEDs in series. The high clock frequency, 30 MHz, makes the device suitable for high data rate transmission. The 3.3 V voltage supply is useful in applications that interface with a 3.3 V microcontroller.

Maturity status link

[STP16CPC05](#)

1 Summary description

Table 1. Typical current accuracy

Output voltage	Current accuracy		Output current	V _{DD}	Temperature
	Between bits	Between ICs			
≥ 1.3 V	± 1.5 %	± 5 %	≥20 to 100 mA	3.3 V to 5 V	25 °C

1.1 Pin connection and description

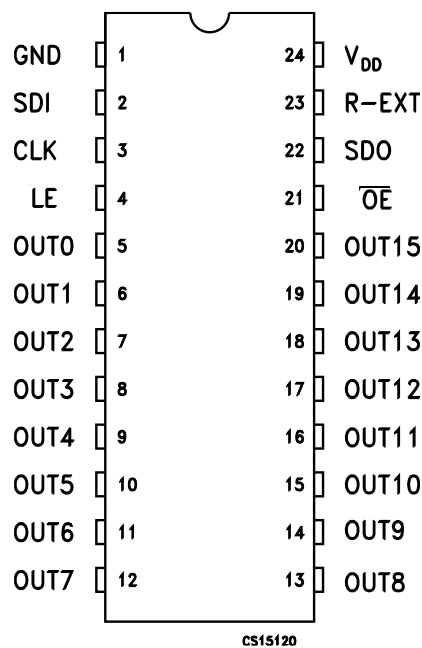
Figure 1. Pin connection

GIPD140320161440MT

Note: The exposed pad should be electrically connected to a metal land electrically isolated or connected to ground.

Table 2. Pin description

Pin n°	Symbol	Name and function
1	GND	Ground terminal
2	SDI	Serial data input terminal
3	CLK	Clock input terminal
4	LE	Latch input terminal
5 - 20	OUT 0 - 15	Output terminal
21	\overline{OE}	Input terminal of output enable (active low)
22	SDO	Serial data out terminal
23	R-EXT	Input terminal for an external resistor for constant current programming
24	V _{DD}	Supply voltage terminal

2 Electrical ratings

2.1 Absolute maximum ratings

Stressing the device above the rating listed in the “absolute maximum ratings” table may cause permanent damage to the device. These are stress ratings only and operation of the device at these or any other conditions above those indicated in the operating sections of this specification is not implied. Exposure to absolute maximum rating conditions for extended periods may affect device reliability.

Table 3. Absolute maximum ratings

Symbol	Parameter	Value	Unit
V_{DD}	Supply voltage	0 to 7	V
V_O	Output voltage	-0.5 to 20	V
I_O	Output current	100	mA
V_I	Input voltage	-0.4 to $V_{DD}+0.4$	V
I_{GND}	GND terminal current	1600	mA
f_{CLK}	Clock frequency	50	MHz

2.2 Thermal data

Table 4. Thermal data

Symbol	Parameter	Value	Unit	
T_{OPR}	Operating temperature range	-40 to +125	°C	
T_{STG}	Storage temperature range	-55 to +150	°C	
R_{thja}	Thermal resistance junction-ambient	SO-24	60	°C/W
		TSSOP24	85	°C/W
		TSSOP24 exposed pad ⁽¹⁾	37.5	°C/W
		QSOP-24	72	°C/W

1. The exposed pad should be soldered directly to the PCB to realize the thermal benefits.

2.3 Recommended operating conditions

Table 5. Recommended operating conditions $T_A = 25\text{ °C}$

Symbol	Parameter	Test conditions	Min.	Typ.	Max.	Unit
V_{DD}	Supply voltage		3.0	-	5.5	V
V_O	Output voltage			-	20	V
I_O	Output current	OUTn	3	-	100	mA
I_{OH}	Output current	SERIAL-OUT		-	+1	mA
I_{OL}	Output current	SERIAL-OUT		-	-1	mA
V_{IH}	Input voltage		$0.7 V_{DD}$	-	$V_{DD}+0.3$	V
V_{IL}	Input voltage		-0.3	-	$0.3 V_{DD}$	V

Symbol	Parameter	Test conditions	Min.	Typ.	Max.	Unit
t_{wLAT}	LE pulse width	$V_{DD} = 3.0\text{ V to }5.0\text{ V}$	20	-		ns
t_{wCLK}	CLK pulse width		16	-		ns
t_{wEN}	OE pulse width		200	-		ns
$t_{SETUP(D)}$	Setup time for DATA		8	-		ns
$t_{HOLD(D)}$	Hold time for DATA		4	-		ns
$t_{SETUP(L)}$	Setup time for LATCH		5	-		ns
f_{CLK}	Clock frequency	Cascade operation $V_{DD} = 5\text{ V}^{(1)}$		-	30	MHz

1. If the device is connected in cascade, it may not be possible to achieve the maximum data transfer. Please consider the timings carefully.

3 Electrical characteristics

$V_{DD} = 3.3\text{ V to }5\text{ V}$, $T_A = 25\text{ }^\circ\text{C}$, unless otherwise specified.

Table 6. Electrical characteristics

Symbol	Parameter	Test conditions	Min.	Typ.	Max.	Unit
V_{IH}	Input voltage high level		$0.7 V_{DD}$		V_{DD}	V
V_{IL}	Input voltage low level		GND		$0.3 V_{DD}$	V
I_{OH}	Output leakage current	$V_{OH} = 20\text{ V}$			10	μA
V_{OL}	Output voltage (serial-OUT)	$I_{OL} = 1\text{ mA}$			0.4	V
V_{OH}	Output voltage (serial-OUT)	$I_{OH} = -1\text{ mA}$	$V_{DD}-0.4\text{ V}$			V
I_{OL1}	Output current	$V_O = 0.3\text{ V}$, $R_{ext} = 4.2\text{ k}\Omega$	4.25	5	5.75	mA
I_{OL2}		$V_O = 0.3\text{ V}$, $R_{ext} = 1\text{ k}\Omega$	19	20	21	
I_{OL3}		$V_O = 1.3\text{ V}$, $R_{ext} = 200\ \Omega$	96	100	104	
ΔI_{OL1}	Output current error between bit (all output ON)	$V_O = 0.3\text{ V}$, $R_{ext} = 4.2\text{ k}\Omega$		± 5	± 8	%
ΔI_{OL2}		$V_O = 0.3\text{ V}$, $R_{ext} = 1\text{ k}\Omega$		± 1.5	± 3	
ΔI_{OL3}		$V_O = 1.3\text{ V}$, $R_{ext} = 200\ \Omega$		± 1.2	± 3	
$R_{SIN(up)}$	Pull-up resistor		150	300	600	k Ω
$R_{SIN(down)}$	Pull-down resistor		100	200	400	k Ω
$I_{DD(OFF1)}$	Supply current (OFF)	$R_{ext} = 1\text{ k}\Omega$, OUT 0 to 15 = OFF		4		mA
$I_{DD(OFF2)}$		$R_{ext} = 250\ \Omega$, OUT 0 to 15 = OFF		11.2		
$I_{DD(ON1)}$	Supply current (ON)	$R_{ext} = 1\text{ k}\Omega$, OUT 0 to 15 = ON		4.5		
$I_{DD(ON2)}$		$R_{ext} = 250\ \Omega$, OUT 0 to 15 = ON		11.7		
Thermal	Thermal protection			170		$^\circ\text{C}$

$V_{DD} = 5\text{ V}$, $T_A = 25\text{ }^\circ\text{C}$, unless otherwise specified.

Table 7. Switching characteristics

Symbol	Parameter	Test conditions	Min.	Typ.	Max.	Unit	
t _{PLH1}	CLK- $\overline{\text{OUTn}}$, LE = H, $\overline{\text{OE}}$ = L Propagation delay time,	$V_{IH} = V_{DD}$ $V_{IL} = \text{GND}$ $C_L = 10$ pF $I_O = 20$ mA $V_L = 3.0$ V $R_{EXT} = 1$ K Ω $R_L = 60$ Ω	V _{DD} = 3.3 V	-	175	227	ns
			V _{DD} = 5 V	-	159	206	
t _{PLH2}	LE- $\overline{\text{OUTn}}$, $\overline{\text{OE}}$ = L Propagation delay time,		V _{DD} = 3.3 V	-	176	228	ns
			V _{DD} = 5 V	-	158	205	
t _{PLH3}	$\overline{\text{OE}}$ - $\overline{\text{OUTn}}$, LE = H Propagation delay time,		V _{DD} = 3.3 V	-	235	305	ns
			V _{DD} = 5 V	-	192	250	
t _{PLH}	CLK-SDO Propagation delay time,		V _{DD} = 3.3 V	-	20	26	ns
			V _{DD} = 5 V	-	14	18	
t _{PHL1}	CLK- $\overline{\text{OUTn}}$, LE = H, $\overline{\text{OE}}$ = L Propagation delay time,		V _{DD} = 3.3 V	-	70	91	ns
			V _{DD} = 5 V	-	68	88	
t _{PHL2}	LE- $\overline{\text{OUTn}}$, $\overline{\text{OE}}$ = L Propagation delay time,	V _{DD} = 3.3 V	-	56	73	ns	
		V _{DD} = 5 V	-	54	70		
t _{PHL3}	$\overline{\text{OE}}$ - $\overline{\text{OUTn}}$, LE = H Propagation delay time,	V _{DD} = 3.3 V	-	102	132	ns	
		V _{DD} = 5 V	-	100	130		
t _{PHL}	CLK-SDO Propagation delay time,	V _{DD} = 3.3 V	-	25	32	ns	
		V _{DD} = 5 V	-	17	22		
t _{ON}	Output rise time 10~90% of voltage waveform	V _{DD} = 3.3 V	-	116	150	ns	
		V _{DD} = 5 V	-	108	140		
t _{OFF}	Output fall time 90~10% of voltage waveform	V _{DD} = 3.3 V	-	80	104	ns	
		V _{DD} = 5 V	-	80	104		
t _r	CLK rise time ⁽¹⁾		-		5000	ns	
t _f	CLK fall time ⁽¹⁾		-		5000	ns	

1. In order to achieve high cascade data transfer, please consider tr/tf timings carefully.

4 Equivalent circuit and outputs

Figure 2. \overline{OE} terminal

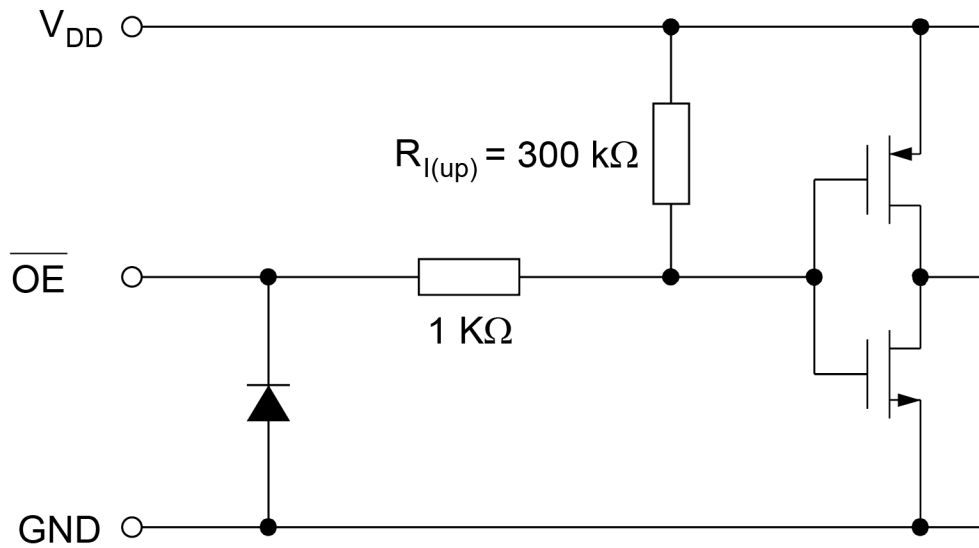

Figure 3. LE terminal

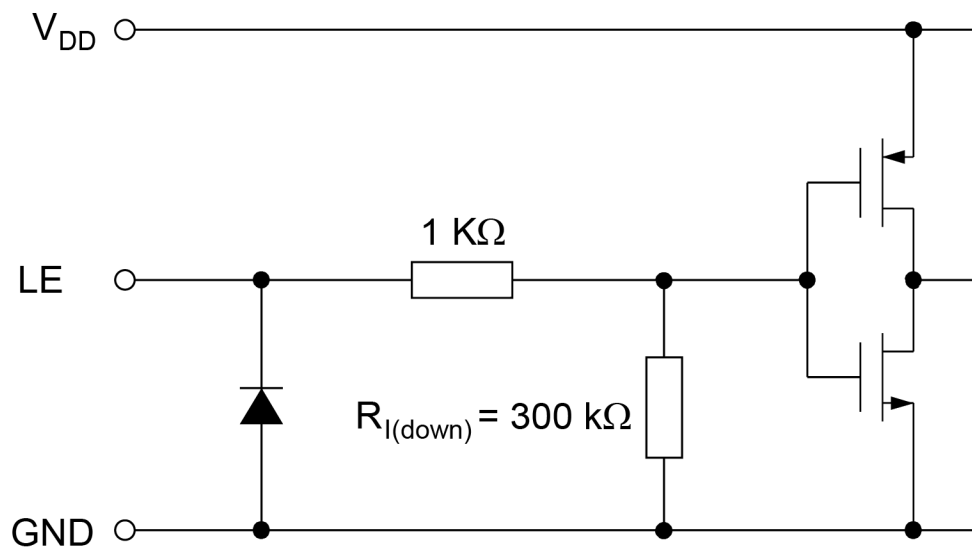

Figure 4. CLK, SDI terminal

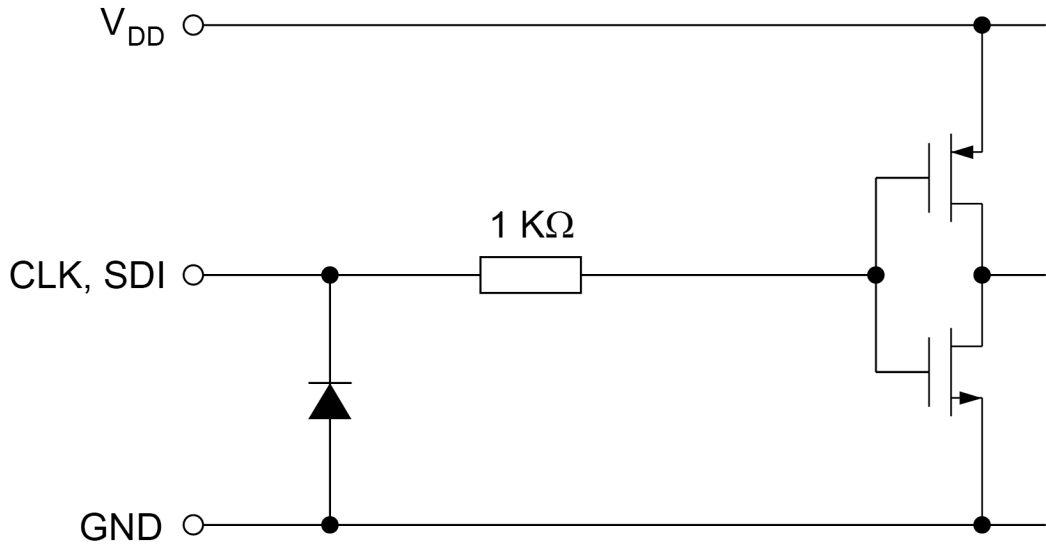
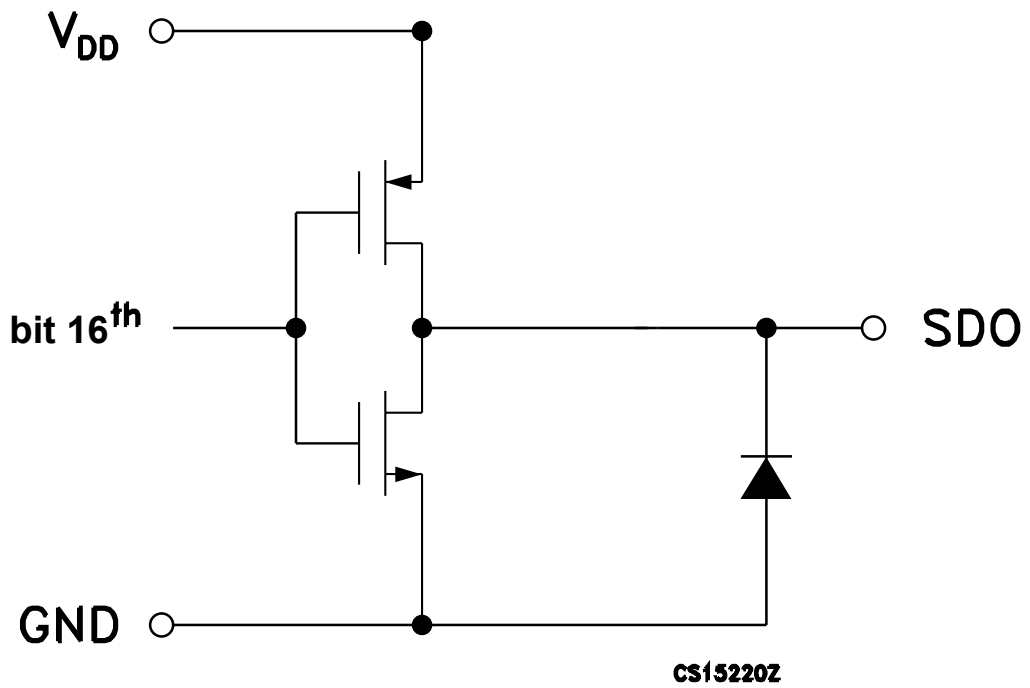
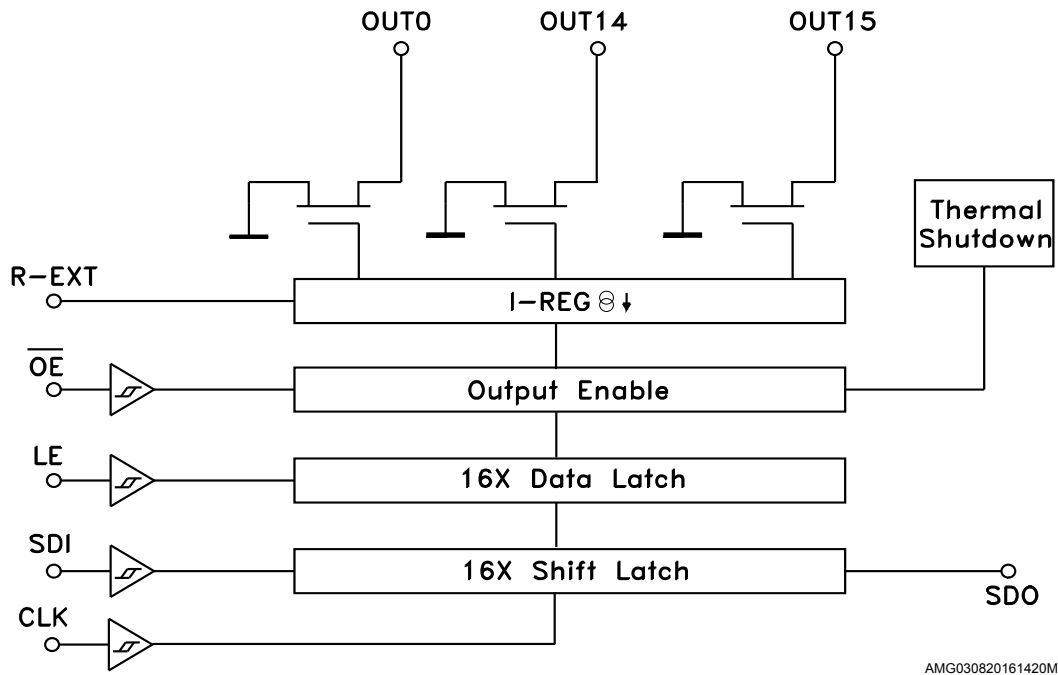

Figure 5. SDO terminal



AMG130220170700MT

Figure 6. Block diagram



5 Timing diagrams

Table 8. Truth table

CLOCK	LE	\overline{OE}	Serial -IN	$\overline{OUT0}$ $\overline{OUT7}$ $\overline{OUT15}$	SDO
	H	L	Dn	Dn Dn - 7 Dn - 15	Dn - 15
	L	L	Dn + 1	No change	Dn - 14
	H	L	Dn + 2	Dn + 2 Dn - 5 Dn - 13	Dn - 13
	X	L	Dn + 3	Dn + 2 Dn - 5 Dn - 13	Dn - 13
	X	H	Dn + 3	OFF	Dn - 13

Note: $OUTn = ON$ when $Dn = H$ $OUTn = OFF$ when $Dn = L$.

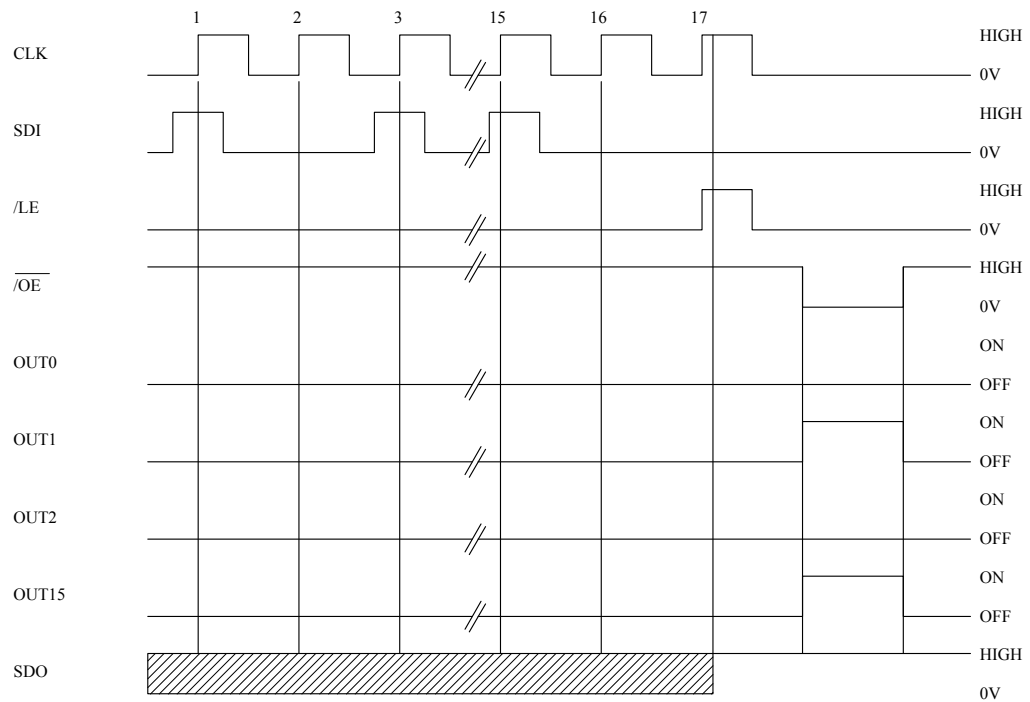
Figure 7. Timing diagram

Note:

- 1 When \overline{LE} terminal is at high level, latch circuit does not hold the data it passes from the input to the output.
- 2 When \overline{OE} terminal is at low level, output terminals $OUT0$ to $OUT15$ respond to the data, either ON or OFF.
- 3 When \overline{OE} terminal is at high level, it switches off all the data on the output terminal.

Figure 8. Clock, serial-in, serial-out

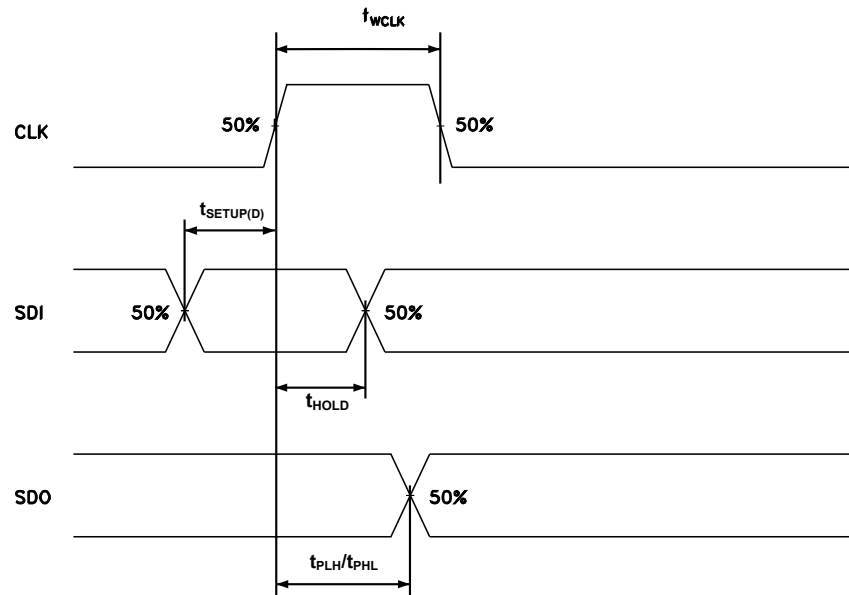

AMG130220170701MT

Figure 9. Clock, serial-in, latch, enable, outputs

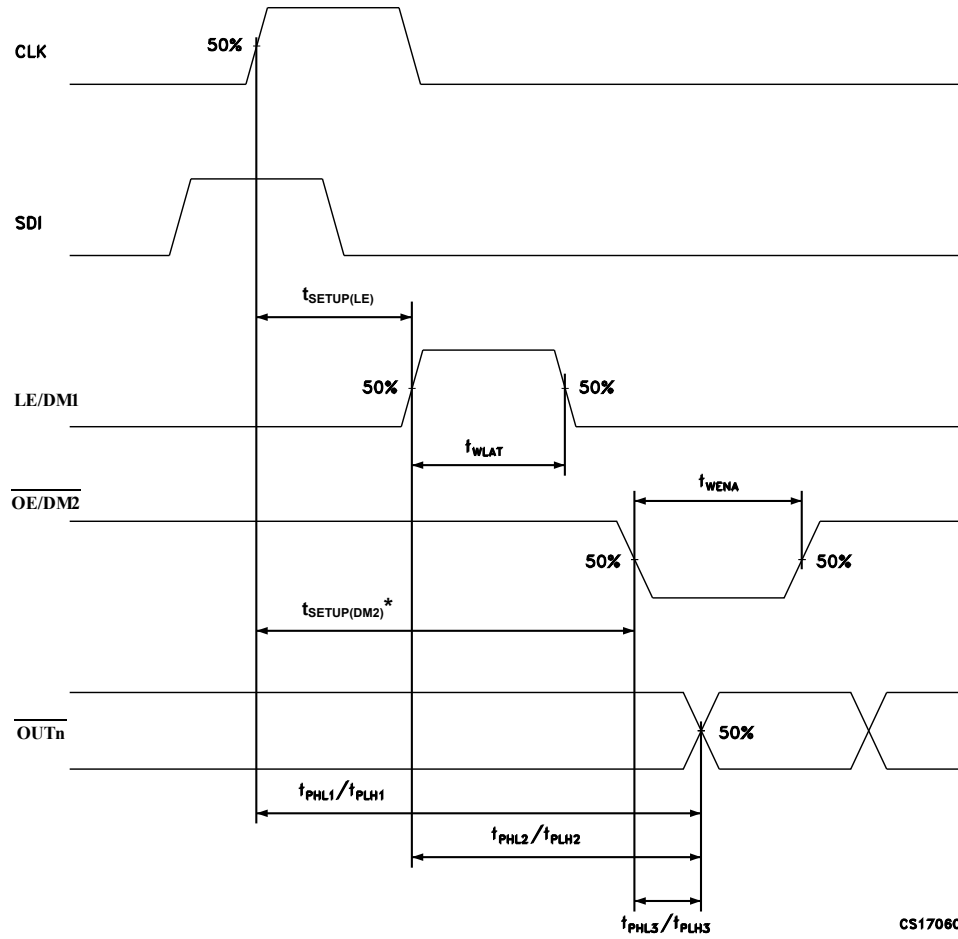

CS17060

* Only for detection feature.

AMG130220170702MT

Figure 10. Outputs

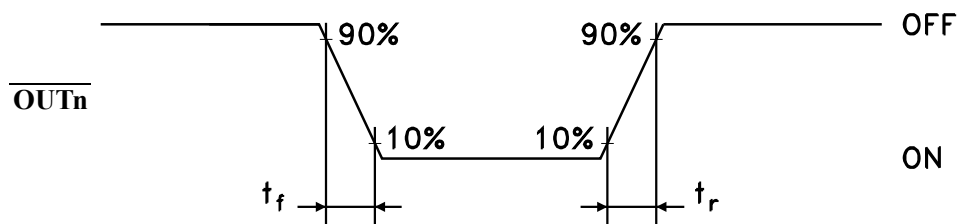

CS17070

GIPD300920151146MT

6 Typical characteristics

Figure 11. Output current- R_{EXT} resistor

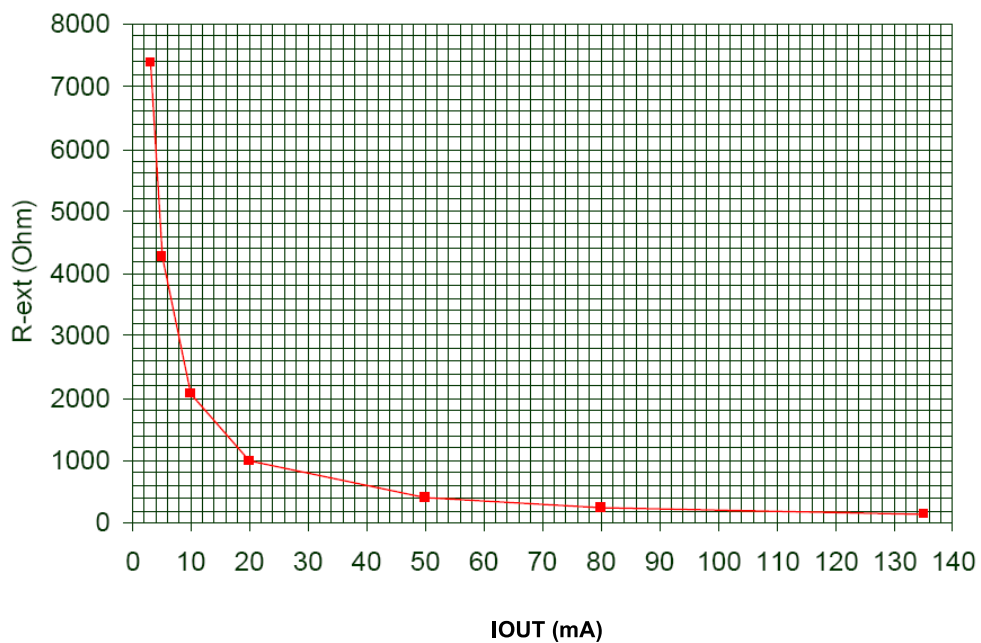

GIPD051020151340MT

Table 9. Output current- R_{EXT} resistor

R_{EXT} (Ω)	Output current (mA)
7370	3
4270	5
2056	10
1006	20
382	50
251	80
200	100

Figure 12. Output current vs $\pm \Delta I_{OL}(\%)$ $T_A = 25^\circ C$

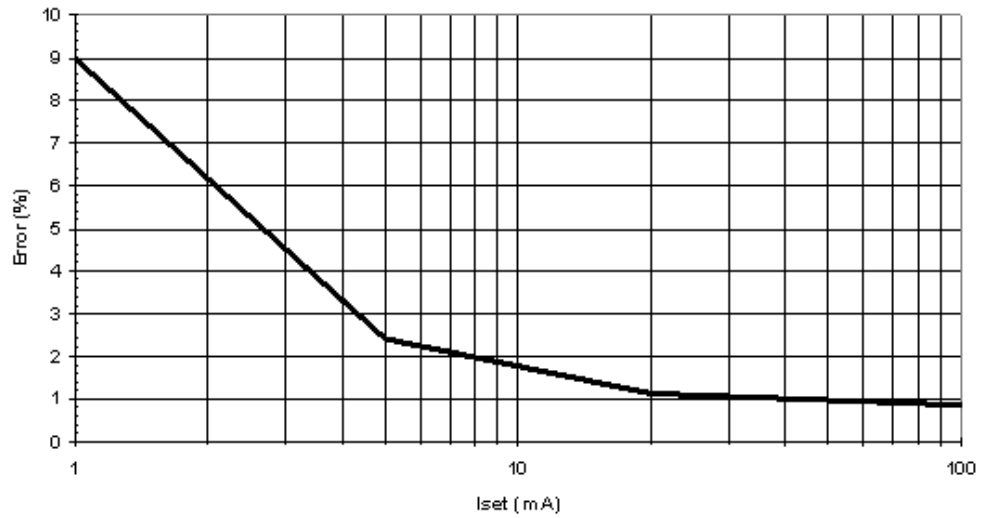

GIPD051020151346MT

Figure 13. I_{SET} vs drop out voltage (V_{drop}) $T_A = 25^\circ C$

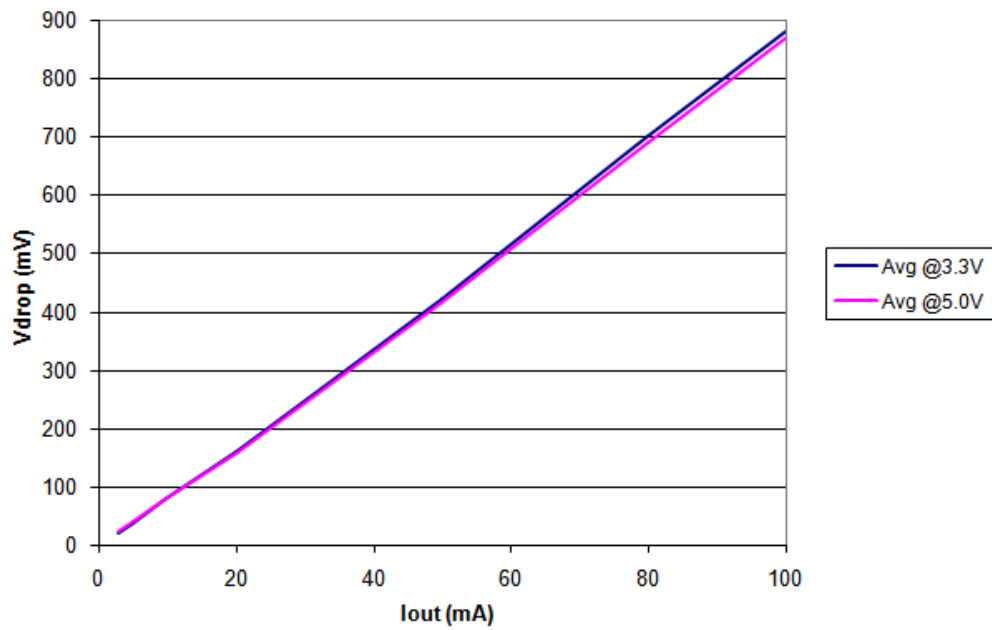

GIPD051020151348MT

Table 10. I_{SET} vs. dropout voltage (V_{drop})

I _{out} (mA)	Avg @ 3.3 V	Avg @ 5.0 V
3	20	22
5	37	40
10	79	79
20	160	158
50	422	415
80	700	690
100	880	870

Figure 14. I_{DD} ON/OFF, T_A = 25 °C

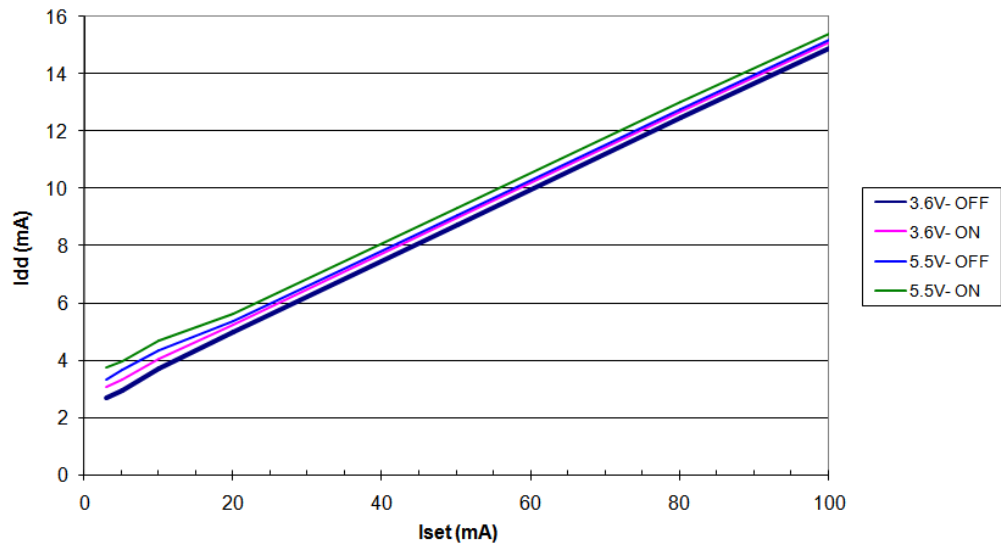

GIPD051020151353MT

7 Test circuit

Figure 15. DC characteristic

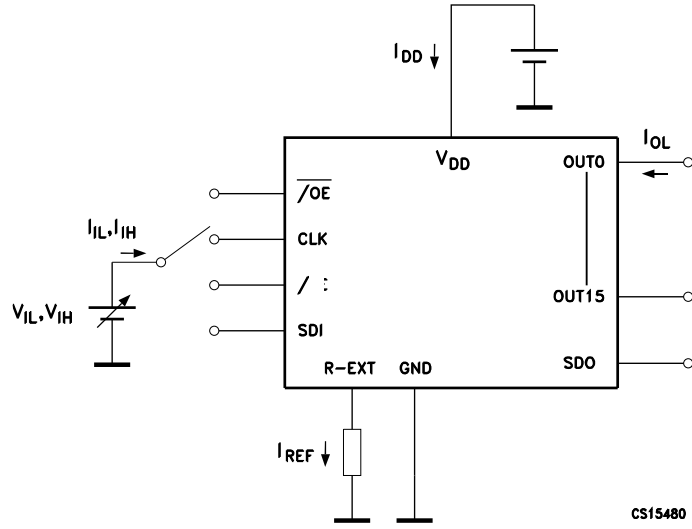

GIPD150320161338MT

Figure 16. AC characteristic

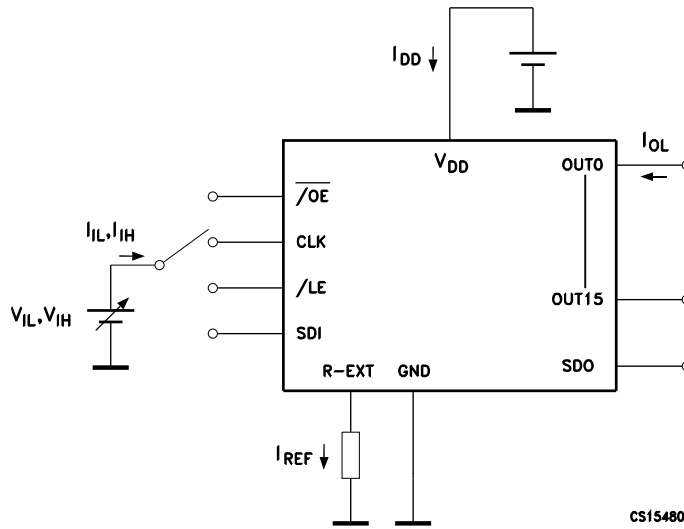

GIPD150320161339MT

Figure 17. Typical application schematic

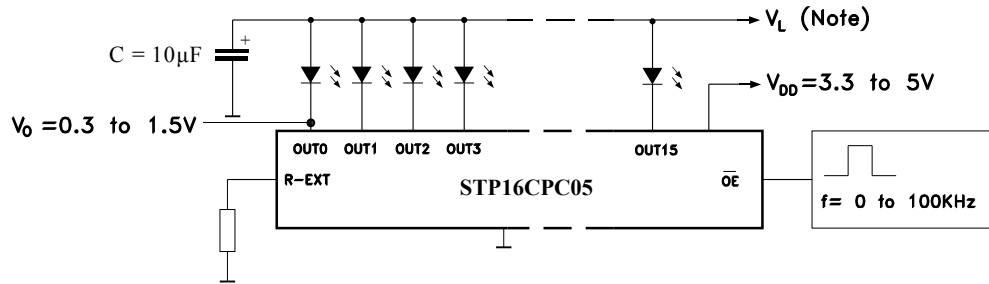

GIPD120420161338MT

Note: V_L will be determined by the V_F of the LEDs.
Test condition: temp. = 25 °C, V_{DD} = 3.0 V, C_L = 10 pF, freq. = 1 MHz.

Figure 18. Turn ON output current setup

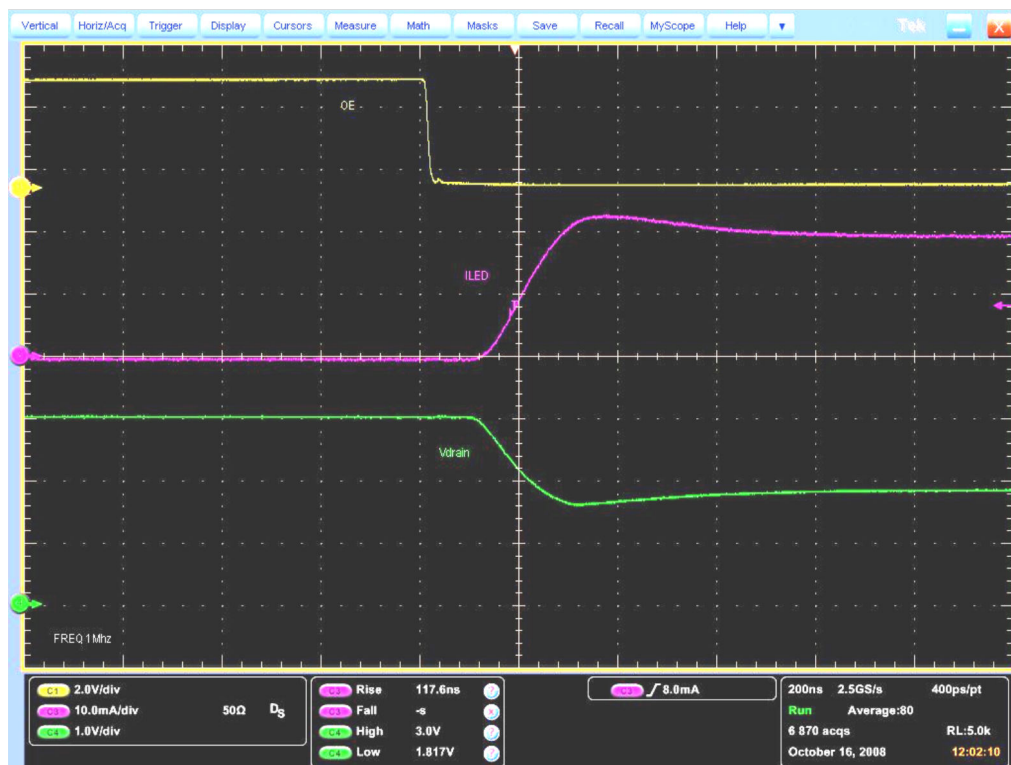

GIPD120420161350MT

Figure 19. Turn OFF output current setup

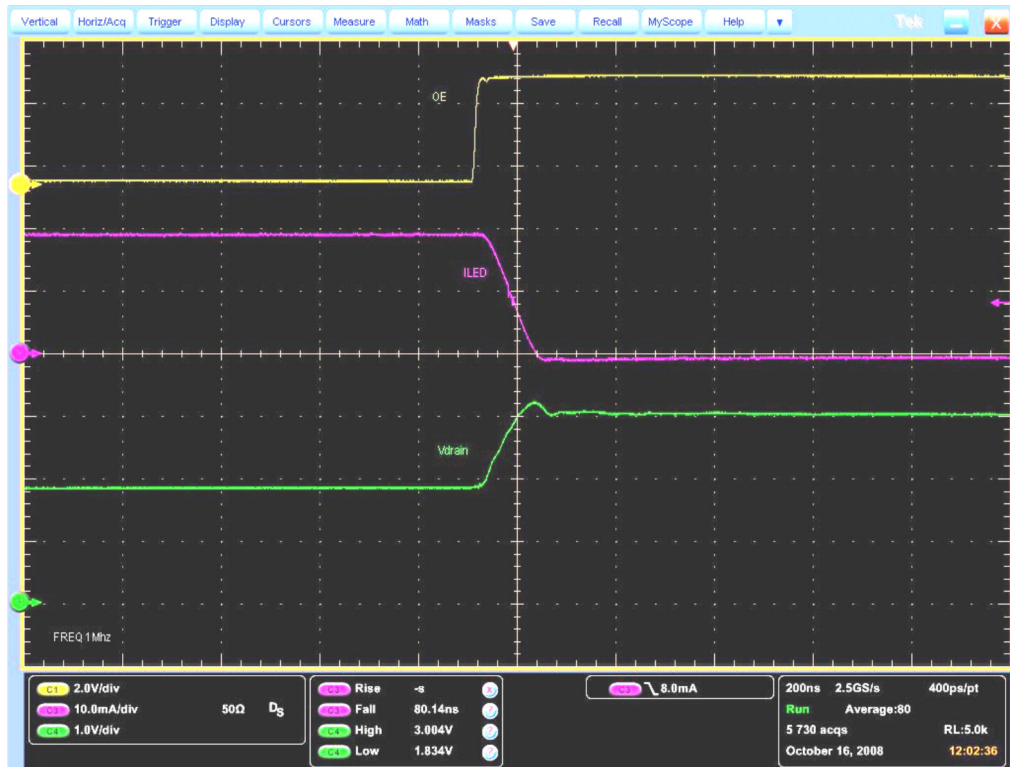

GIPD120420161350MT

8 Package information

In order to meet environmental requirements, ST offers these devices in different grades of **ECOPACK** packages, depending on their level of environmental compliance. ECOPACK specifications, grade definitions and product status are available at: www.st.com. ECOPACK is an ST trademark.

8.1 QSOP-24 package information

Figure 20. QSOP-24 package outline

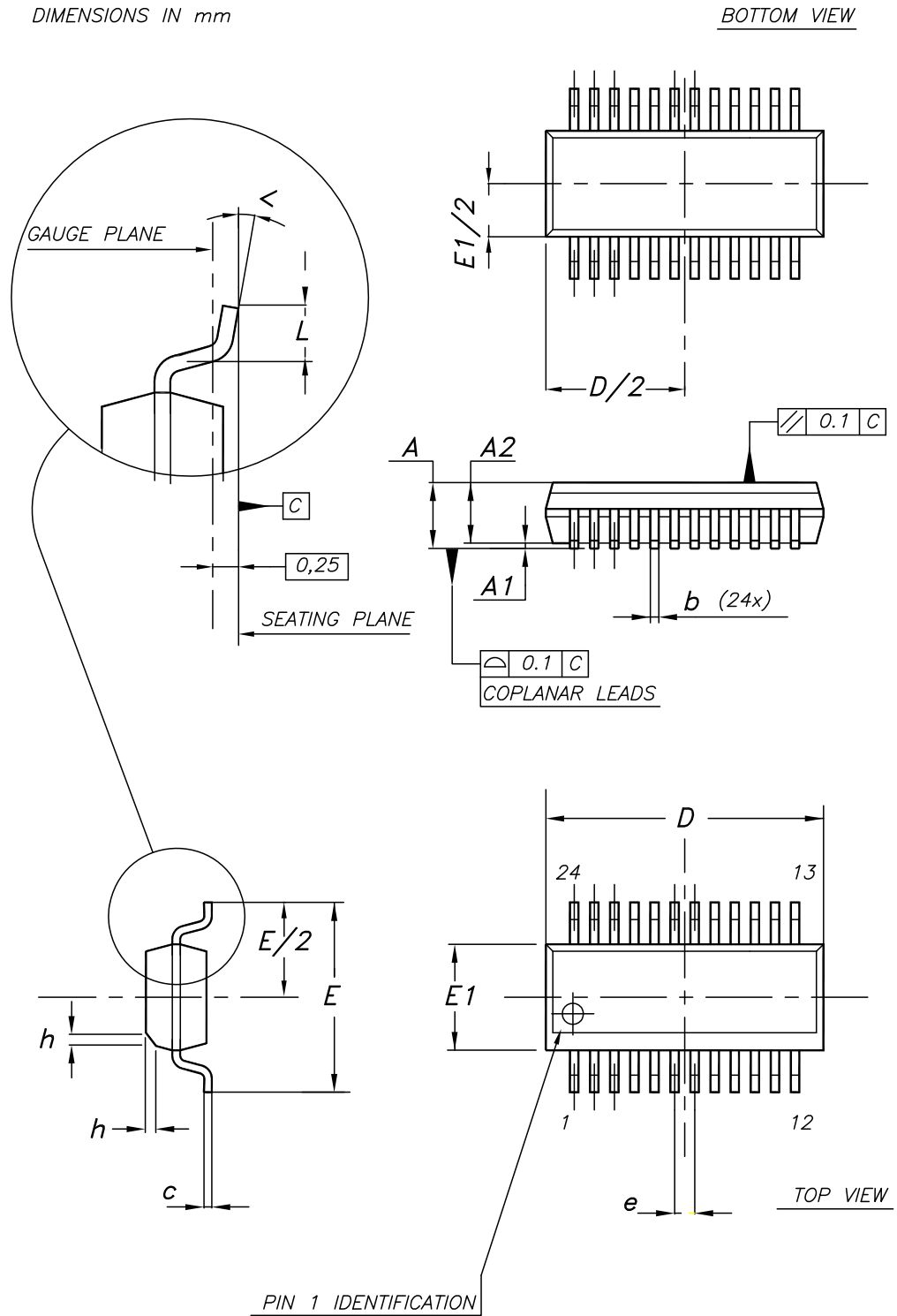
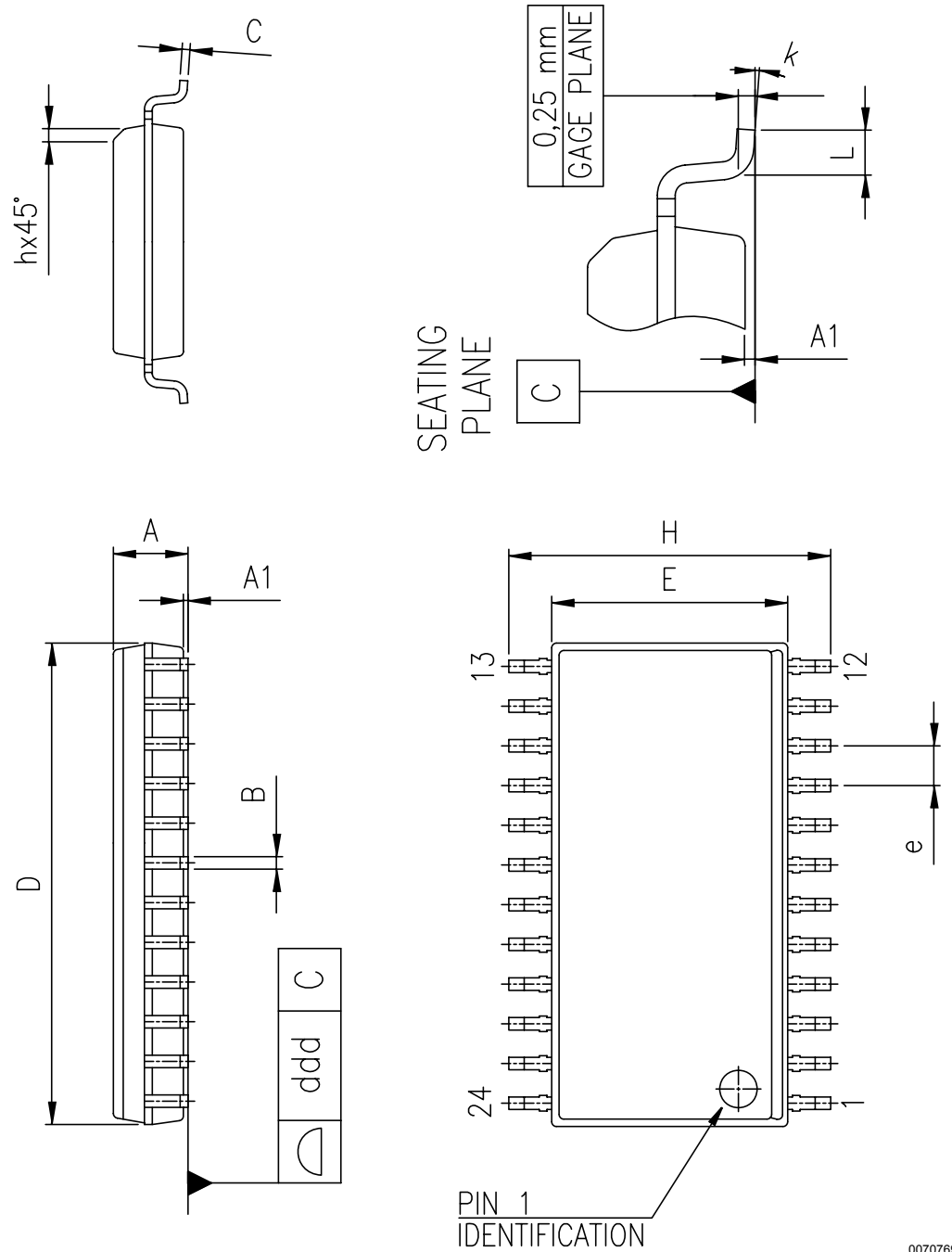

Table 11. QSOP-24 mechanical data

Dim.	mm		
	Min.	Typ.	Max.
A	1.54	1.62	1.73
A1	0.10	0.15	0.25
A2		1.47	
b	0.20		0.31
c	0.17		0.254
D	8.56	8.66	8.76
E	5.80	6.00	6.20
E1	3.80	3.91	4.01
e		0.635	
L	0.40	0.635	0.89
h	0.25	0.33	0.41
<	0°		8°

8.2 SO-24 0070769 package information

Figure 21. SO-24 package outline



0070769

Table 12. SO-24 mechanical data

Dim.	mm		
	Min.	Typ.	Max.
A	2.35		2.65
A1	0.10		0.30
B	0.33		0.51
C	0.23		0.32
D	15.20		15.60
E	7.40		7.60
e		1.27	
H	10.00		10.65
h	0.25		0.75
L	0.40		1.27
k	0		8
ddd			0.10

8.3 TSSOP24 package information

Figure 22. TSSOP24 package outline

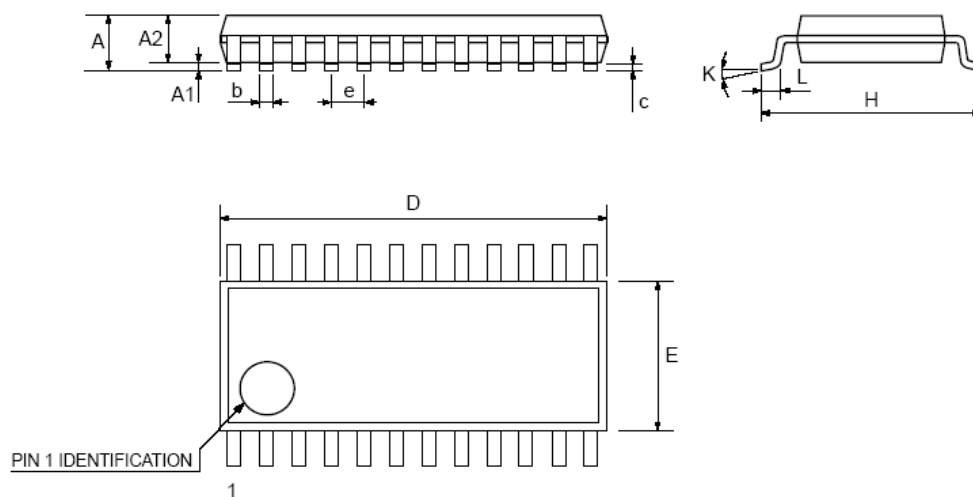

7047476B

Table 13. TSSOP24 mechanical data

Dim.	mm		
	Min.	Typ.	Max.
A			1.1
A1	0.05		0.15
A2		0.9	
b	0.19		0.30
c	0.09		0.20
D	7.7		7.9
E	4.3		4.5
e		0.65 BSC	
H	6.25		6.5
K	0°		8°
L	0.50		0.70

8.4 TSSOP24 exposed pad package information

Figure 23. TSSOP24 exposed pad package outline

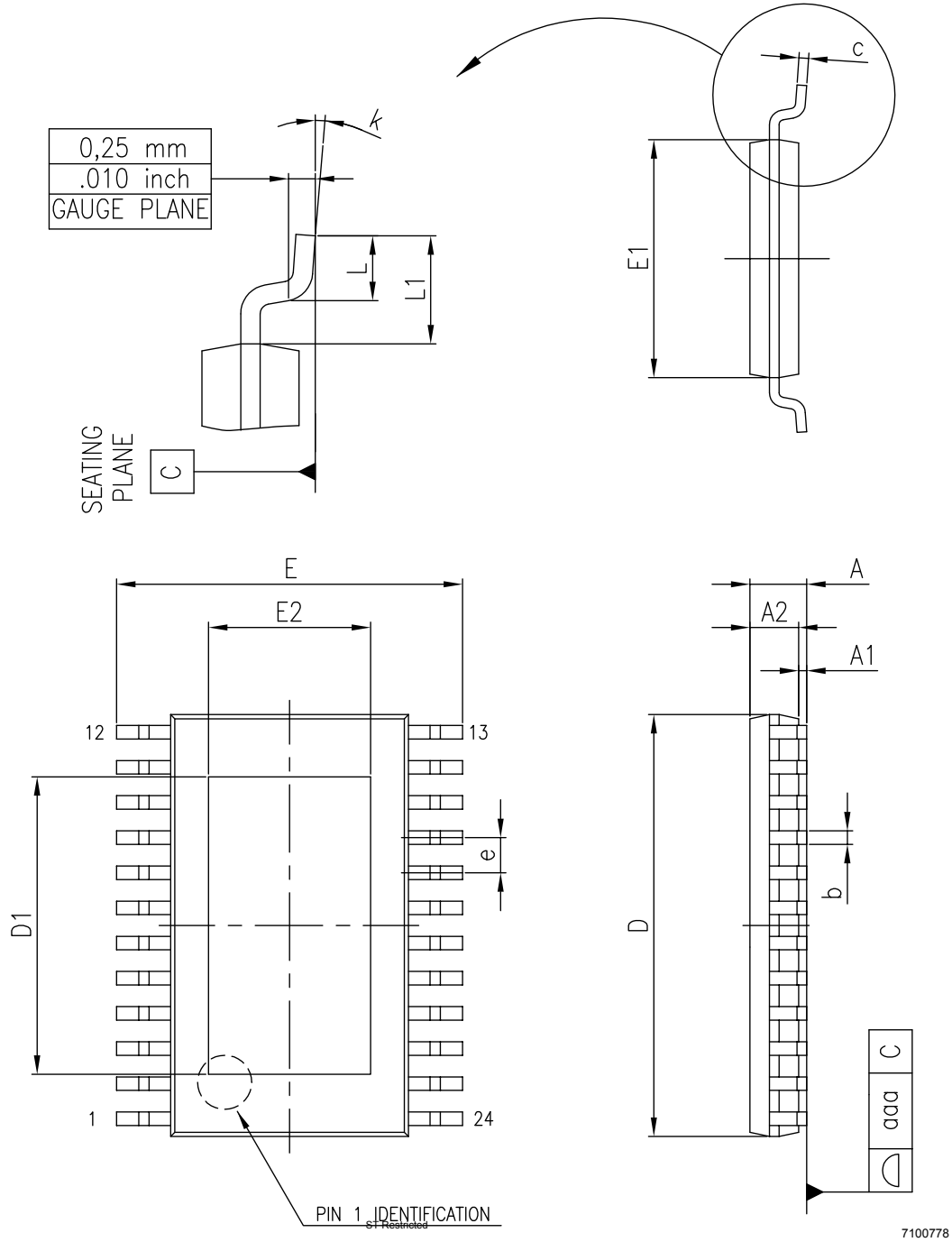

Table 14. TSSOP24 exposed pad mechanical data

Dim.	mm		
	Min.	Typ.	Max.
A			1.20
A1			0.15
A2	0.80	1.00	1.05
b	0.19		0.30
c	0.09		0.20
D	7.70	7.80	7.90
D1	4.80	5.00	5.20
E	6.20	6.40	6.60
E1	4.30	4.40	4.50
E2	3.00	3.20	3.40
e			
L	0.45	0.60	0.75
L1		1.00	
K	0		8
aaa			0.10

8.5 TSSOP24, TSSOP24 exposed pad and SO-24 packing information

Figure 24. TSSOP24, TSSOP24 exposed pad and SO-24 reel outline

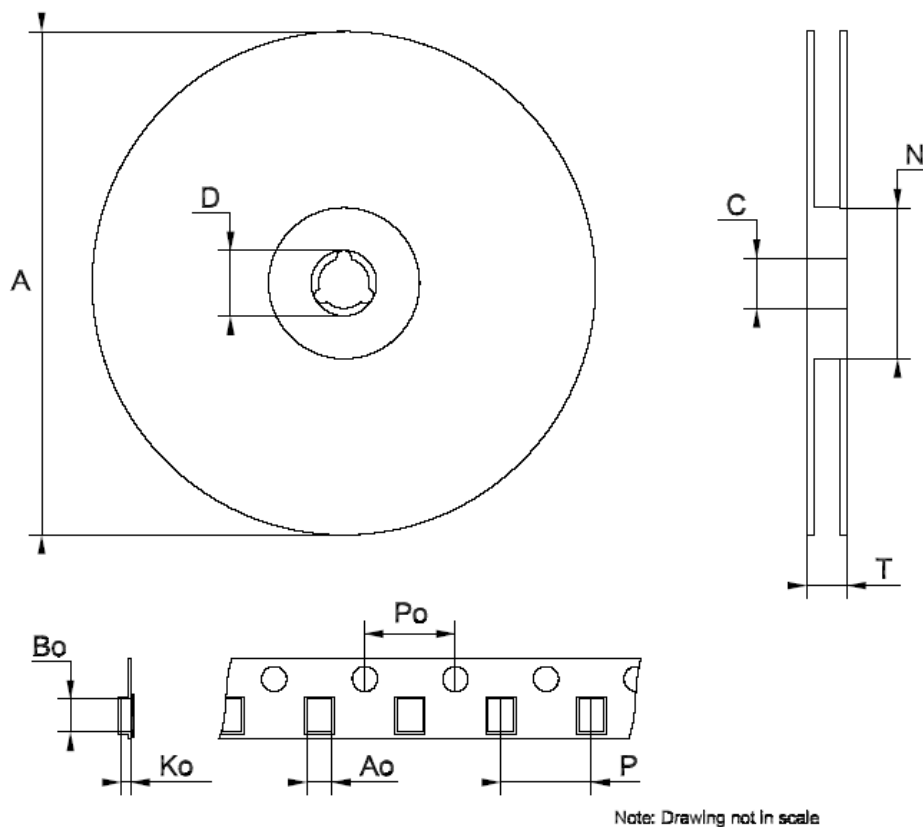

Table 15. TSSOP24 and TSSOP24 exposed pad tape and reel mechanical data

Dim.	mm		
	Min.	Typ.	Max.
A	330	-	331
C	13.0	-	14.0
D	18.7	-	
N	100	-	
T	16.5	-	18.5
Ao	6.85	-	7.05
Bo	8.20	-	8.40
Ko	1.5	-	1.7
Po	3.9	-	4.1
P	7.9	-	8.1

Table 16. SO-24 tape and reel mechanical data

Dim.	mm		
	Min.	Typ.	Max.
A		-	330
C	12.8	-	13.2
D	20.2	-	
N	60	-	
T		-	30.4
Ao	10.8	-	11.0
Bo	15.7	-	15.9
Ko	2.9	-	3.1
Po	3.9	-	4.1
P	11.9	-	12.1

9 Device summary

Table 17. Device summary

Order code	Package	Packing
STP16CPC05MTR	SO-24	1000 parts per reel
STP16CPC05TTR	TSSOP24	2500 parts per reel
STP16CPC05XTTR	TSSOP24 exposed pad	2500 parts per reel
STP16CPC05PTR	QSOP-24	2500 parts per reel

Revision history

Table 18. Document revision history

Date	Revision	Changes
30-Jan-2009	1	First release
12-May-2009	2	Updated Table 6 on page 6
29-Oct-2009	3	Updated Note: on page 3
16-Jun-2014	4	Updated Section 8: Package mechanical data. Added Section 9: Packaging mechanical data. Minor text changes.
08-Mar-2017	5	Updated Table 5: "Thermal data", Figure 5: "SDO terminal", Figure 8: "Clock, serial-in, serial-out", Figure 9: "Clock, serial-in, latch, enable, outputs" and Section 8: "Package information". Minor text changes
07-Sep-2023	6	Updated Table 15 .

Contents

1	Summary description	2
1.1	Pin connection and description	2
2	Electrical ratings	3
2.1	Absolute maximum ratings	3
2.2	Thermal data	3
2.3	Recommended operating conditions	3
3	Electrical characteristics	5
4	Equivalent circuit and outputs	7
5	Timing diagrams	10
6	Typical characteristics	13
7	Test circuit	16
8	Package information	19
8.1	QSOP-24 package information	20
8.2	SO-24 0070769 package information	22
8.3	TSSOP24 package information	24
8.4	TSSOP24 exposed pad package information	25
8.5	TSSOP24, TSSOP24 exposed pad and SO-24 packing information	27
9	Device summary	29
	Revision history	30

List of tables

Table 1.	Typical current accuracy	2
Table 2.	Pin description	2
Table 3.	Absolute maximum ratings	3
Table 4.	Thermal data	3
Table 5.	Recommended operating conditions $T_A = 25\text{ }^\circ\text{C}$	3
Table 6.	Electrical characteristics	5
Table 7.	Switching characteristics	6
Table 8.	Truth table	10
Table 9.	Output current- R_{EXT} resistor	13
Table 10.	I_{SET} vs. dropout voltage (V_{drop})	15
Table 11.	QSOP-24 mechanical data	21
Table 12.	SO-24 mechanical data	23
Table 13.	TSSOP24 mechanical data	24
Table 14.	TSSOP24 exposed pad mechanical data	26
Table 15.	TSSOP24 and TSSOP24 exposed pad tape and reel mechanical data	27
Table 16.	SO-24 tape and reel mechanical data	28
Table 17.	Device summary	29
Table 18.	Document revision history	30

List of figures

Figure 1.	Pin connection	2
Figure 2.	\overline{OE} terminal	7
Figure 3.	LE terminal	7
Figure 4.	CLK, SDI terminal	8
Figure 5.	SDO terminal	8
Figure 6.	Block diagram	9
Figure 7.	Timing diagram.	10
Figure 8.	Clock, serial-in, serial-out.	11
Figure 9.	Clock, serial-in, latch, enable, outputs	12
Figure 10.	Outputs	12
Figure 11.	Output current- R_{EXT} resistor.	13
Figure 12.	Output current vs $\pm \Delta I_{OL}(\%)$ $T_A = 25^\circ C$	14
Figure 13.	I_{SET} vs drop out voltage (V_{drop}) $T_A = 25^\circ C$	14
Figure 14.	I_{DD} ON/OFF, $T_A = 25^\circ C$	15
Figure 15.	DC characteristic	16
Figure 16.	AC characteristic.	16
Figure 17.	Typical application schematic	17
Figure 18.	Turn ON output current setup	17
Figure 19.	Turn OFF output current setup	18
Figure 20.	QSOP-24 package outline	20
Figure 21.	SO-24 package outline	22
Figure 22.	TSSOP24 package outline	24
Figure 23.	TSSOP24 exposed pad package outline	25
Figure 24.	TSSOP24, TSSOP24 exposed pad and SO-24 reel outline	27

IMPORTANT NOTICE – READ CAREFULLY

STMicroelectronics NV and its subsidiaries (“ST”) reserve the right to make changes, corrections, enhancements, modifications, and improvements to ST products and/or to this document at any time without notice. Purchasers should obtain the latest relevant information on ST products before placing orders. ST products are sold pursuant to ST’s terms and conditions of sale in place at the time of order acknowledgment.

Purchasers are solely responsible for the choice, selection, and use of ST products and ST assumes no liability for application assistance or the design of purchasers’ products.

No license, express or implied, to any intellectual property right is granted by ST herein.

Resale of ST products with provisions different from the information set forth herein shall void any warranty granted by ST for such product.

ST and the ST logo are trademarks of ST. For additional information about ST trademarks, refer to www.st.com/trademarks. All other product or service names are the property of their respective owners.

Information in this document supersedes and replaces information previously supplied in any prior versions of this document.

© 2023 STMicroelectronics – All rights reserved