

M51951A,B/M51952A,B

VOLTAGE DETECTING, SYSTEM RESETTING IC SERIES

DESCRIPTION

M51951A,B/M51952A,B are semiconductor integrated circuits suited for detecting supply voltage and resetting all types of logic circuits such as CPUs.

They include a built-in delay circuit to provide a retardation time (200 μ sec typ.).

They find extensive applications, including circuits for battery checking, level detecting and waveform shaping.

FEATURES

- Few external parts
- Low threshold operating voltage (Supply voltage to keep low-state at low supply voltage
..... 0.6V (TYP.) at $R_L = 22k\Omega$)
- Wide supply voltage range 2 ~ 17V
- Sudden change in power supply has minimal effect on the ICs
- Wide application range
- SIL package of the same height as DIP (5-pin SIP)
- Extra-small 3-pin package (3-pin FLAT)

APPLICATION

Reset circuit of Pch, Nch, CMOS, microcomputer, CPU and microcomputer, Reset of logic circuit, Battery check circuit, Switching circuit back-up voltage, Level detecting circuit, Waveform shaping circuit, Delay waveform generating circuit, DC-DC converter, Over voltage protection circuit.

RECOMMENDED OPERATING CONDITION

Supply voltage range 2 ~ 17V

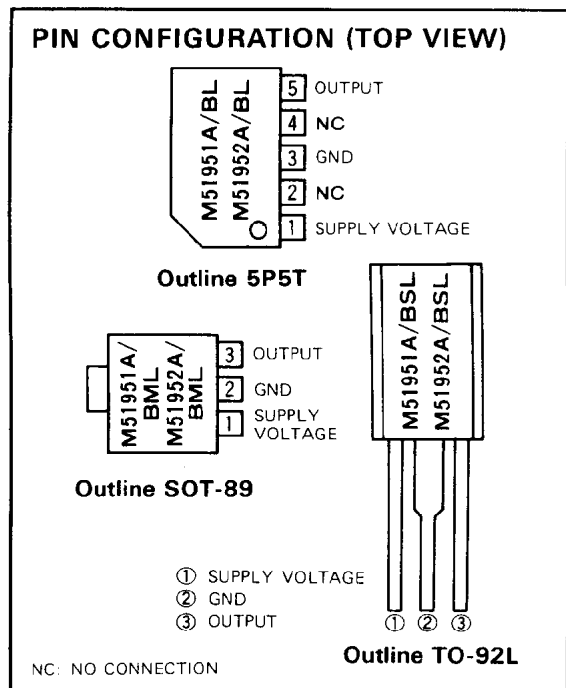

BLOCK DIAGRAM

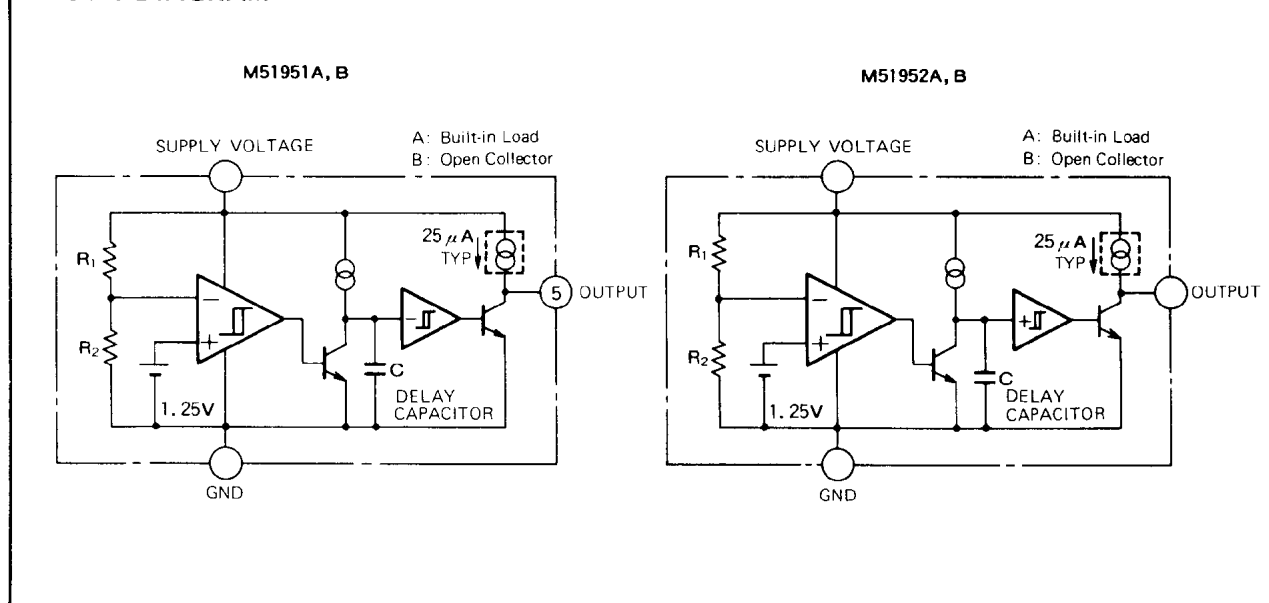

MITSUBISHI <Dig./Ana. INTERFACE>
M51951A,B/M51952A,B

VOLTAGE DETECTING, SYSTEM RESETTIC IC SERIES

FUNCTION DIAGRAM

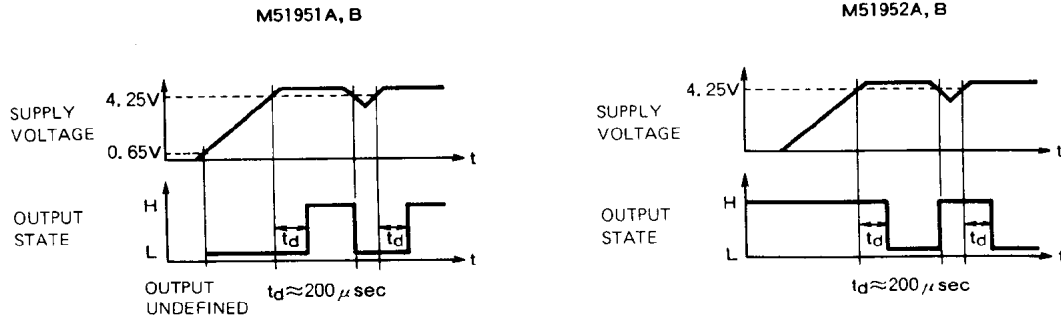

ABSOLUTE MAXIMUM RATINGS ($T_a = 25^\circ\text{C}$, unless otherwise noted)

| Symbol | Parameter | Conditions | Rating | Unit | |
|------------|-----------------------|--|------------|------|-------|
| V_{CC} | Supply voltage | | 18 | V | |
| I_{sink} | Output Sink Current | | 6 | mA | |
| V_O | Output voltage | A Type (Output with constant current load) | V_{CC} | V | |
| | | B Type (Open collector output) | 18 | | |
| P_d | Power dissipation | 5P SIL | 450 | mW | |
| | | 3P SIL | 700 | | |
| | | 3P FLAT | 500 | | |
| K_θ | Thermal Derating | $T_a \geq 25^\circ\text{C}$ | 5P SIL | 4.5 | mW/°C |
| | | | 3P SIL | 7 | |
| | | | 3P FLAT | 5 | |
| T_{opr} | Operating temperature | | -30 ~ +85 | °C | |
| T_{stg} | Storage temperature | | -40 ~ +125 | °C | |

ELECTRICAL CHARACTERISTICS ($T_a = 25^\circ\text{C}$, unless otherwise noted)

| "L" reset type | "H" reset type |
|----------------|----------------|
| M51951A | M51952A |
| M51951B | M51952B |

| Symbol | Parameter | Test conditions | Limits | | | Unit | |
|----------------|---|--|---------------------------------------|-----------------|------|---------------|---|
| | | | Min | Typ | Max | | |
| V_S | Detecting voltage | | 4.05 | 4.25 | 4.45 | V | |
| ΔV_S | Hysteresis voltage | | 30 | 50 | 80 | mV | |
| $V_S/\Delta T$ | Detecting voltage Temperature Coefficient | | — | 0.01 | — | %/°C | |
| I_{CC} | Circuit Current | Type A $V_{CC} = 5V$ | — | 450 | 680 | μA | |
| | | Type B $V_{CC} = 5V$ | — | 420 | 630 | | |
| t_{pd} | Delay Time | $T_a = -30 \sim +85^\circ\text{C}$ (Note) | 80 | 200 | 500 | μs | |
| V_{sat} | Output Saturation Voltage | L reset type $V_{CC} = 4V, I_{sink} = 4mA$ | — | 0.2 | 0.4 | V | |
| | | H reset type $V_{CC} = 5V, I_{sink} = 4mA$ | — | 0.2 | 0.4 | | |
| V_{OPL} | Threshold Operating Voltage | L reset type Minimum supply voltage for IC operation | $R_L = 2.2k\Omega, V_{sat} \leq 0.4V$ | — | 0.67 | 0.8 | V |
| | | | $R_L = 100k\Omega, V_{sat} \leq 0.4V$ | — | 0.55 | 0.7 | |
| I_{OH} | Output Leak Current | Type B | — | — | 30 | nA | |
| | | Type B, $T_a = -30 \sim +85^\circ\text{C}$ | — | — | 1 | μA | |
| I_{OC} | Output Load Current | Type A $V_{CC} = 5V, V_O = 1/2V_{CC}$ | -40 | -25 | -17 | μA | |
| V_{OH} | Output High Voltage | Type A | $V_{CC} - 0.2$ | $V_{CC} - 0.06$ | — | V | |

Note: Delay time can be changed by changing delay capacitor for external capacitor types.
 (Please refer to typical characteristics)

VOLTAGE DETECTING, SYSTEM RESETTIC IC SERIES

TYPICAL CHARACTERISTICS

**TYPICAL CHARACTERISTICS
 THERMAL DERATING
 (MAXIMUM RATING)**

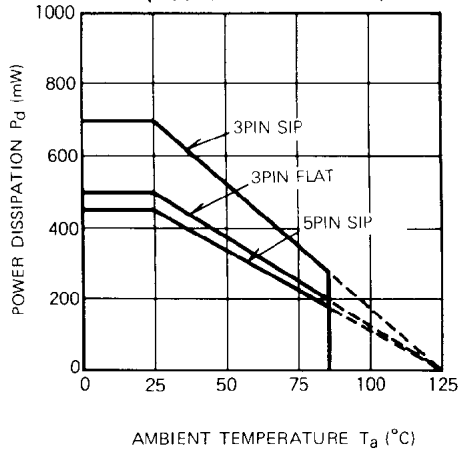

**DETECTING VOLTAGE VS.
 AMBIENT TEMPERATURE
 (Supply voltage detecting series)**

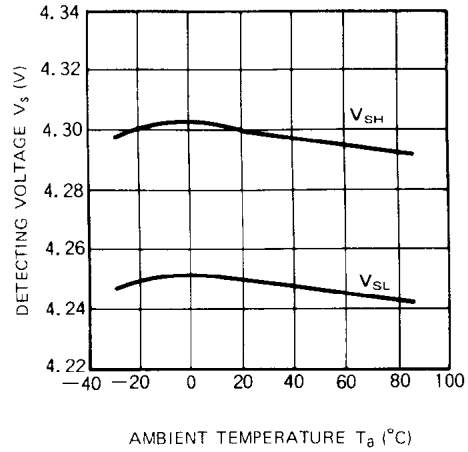

**DELAY TIME VS.
 AMBIENT TEMPERATURE
 (M5195XX, Built-in capacitor type)**

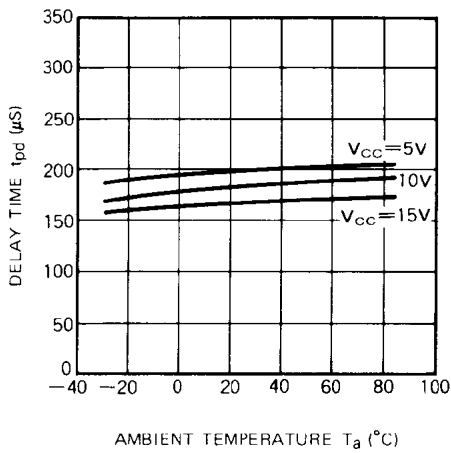

**THRESHOLD OPERATING VOLTAGE
 ([L] reset type)**

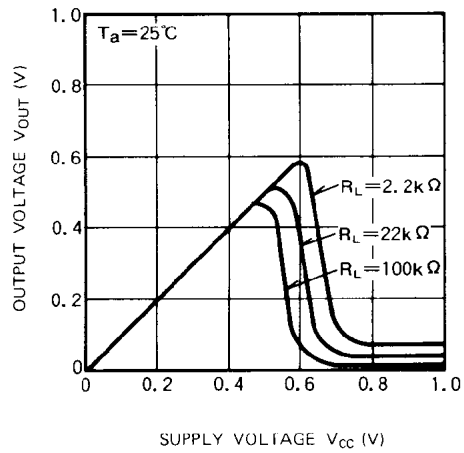

**OUTPUT SATURATION VOLTAGE VS.
 OUTPUT SINK CURRENT**

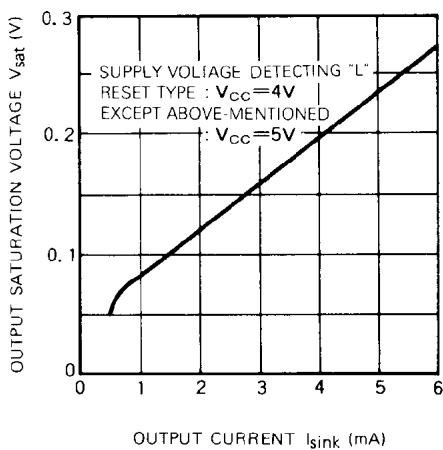

**OUTPUT LOAD CURRENT VS.
 OUTPUT VOLTAGE
 (M519XXA)**

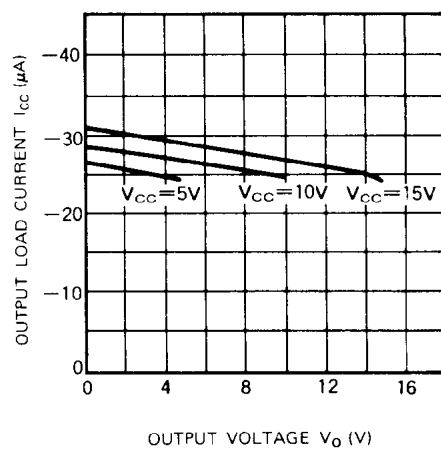

VOLTAGE DETECTING, SYSTEM RESETTING IC SERIES

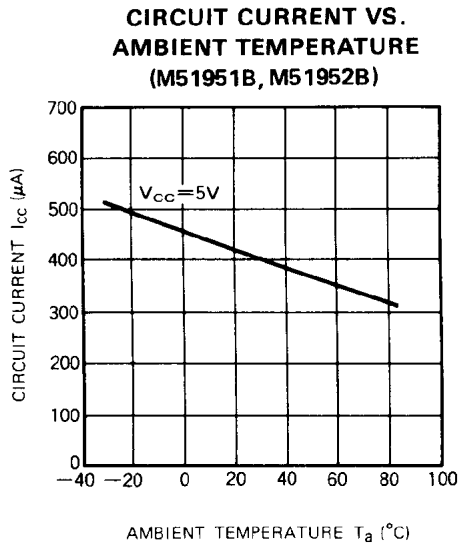

**EXAMPLE OF APPLICATION CIRCUIT
 M5195XX Series Reset Circuit**

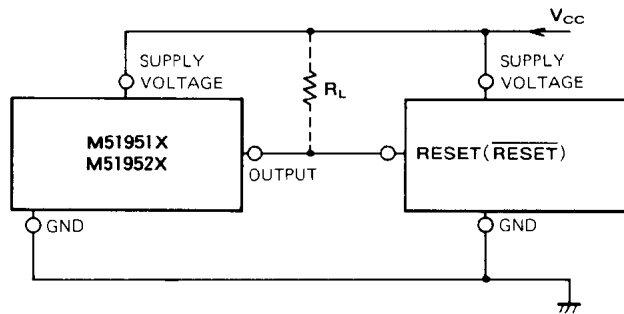

- Note 1. When the detecting supply voltage is 4.25V, M51951, M51952, M51953 and M51954 are used.
 When the voltage is anything except 4.25V, M51955, M51956, M51957, and M51958 are used.
- Note 2. When the delay time is short, M51951, M51952, M51955 and M51956 are available. These ICs have a delay capacity and the delay time is about 200µs.
 If a longer delay time is necessary, M51953, M51954, M51957 and M51958 are used.
- Note 3. If M5195XX and the logic circuit have a common power supply, type A (built-in load type) can be applied whether a pull-up resistor is included in the logic circuit or not.

- Note 4. The logic circuit preferably should not have a pull-down resistor, but if one is present, add load resistor R_L to overcome the pull-down resistor.
- Note 5. When the reset terminal in the logic circuit is of the low reset type, M51951, M51953, M51955 and M51957 are used and when the terminal is of the high reset type, M51952, M51954, M51956 and M51958 are used.
- Note 6. When a negative supply voltage is used, supply voltage side of M5195XX and the GND side are connected to negative supply voltage respectively.