

PROB		LOC	Q1ST	REVISIONS					
CODE	DF	FO	P	F	ZONE	LTR	DESCRIPTION	DATE	APPD
5087						A	REV PER 0600-7172-98 JB	-	-

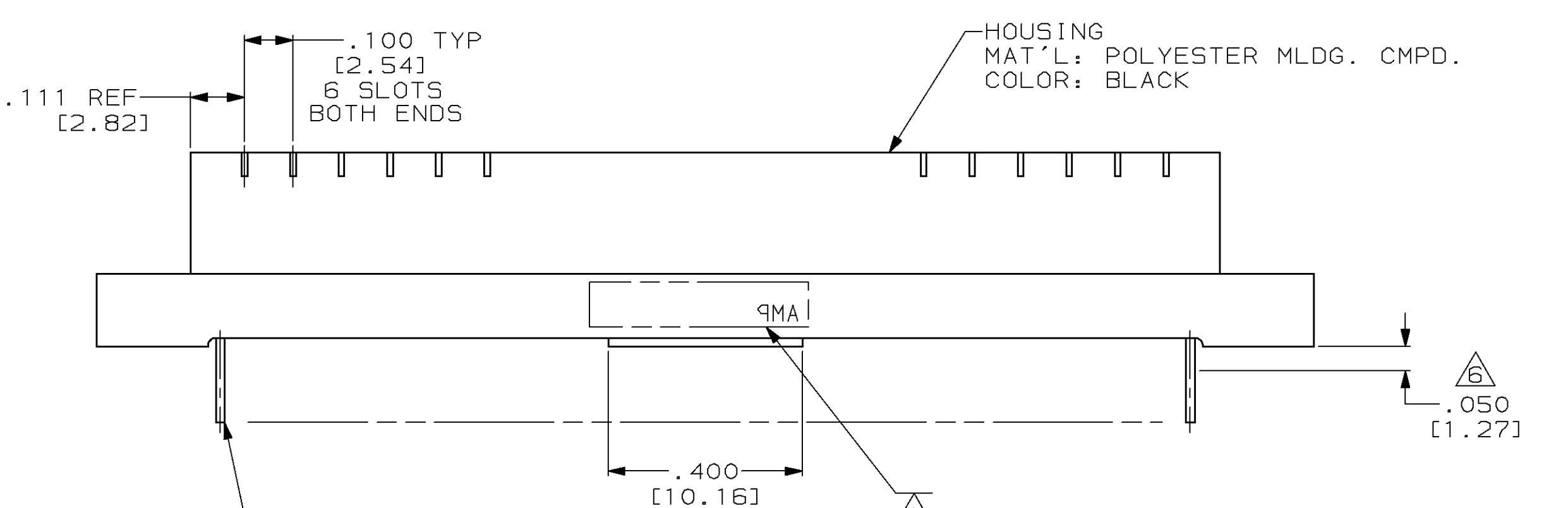

CONTACT, .019 [0.48] MAX X .014 [0.25] MAX CHANNEL (QTY = 62)
 MAT'L: BERYLLIUM COPPER PER QQ-C-530
 FINISH: .000030 [0.0008] GOLD PER MIL-G-45204 IN CONTACT AREA,
 .000100 [0.0025] TIN-LEAD PER MIL-P-81728A ON TAILS OVER
 .000030 [0.0008] NICKEL PER QQ-N-290 ENTIRE CONTACT

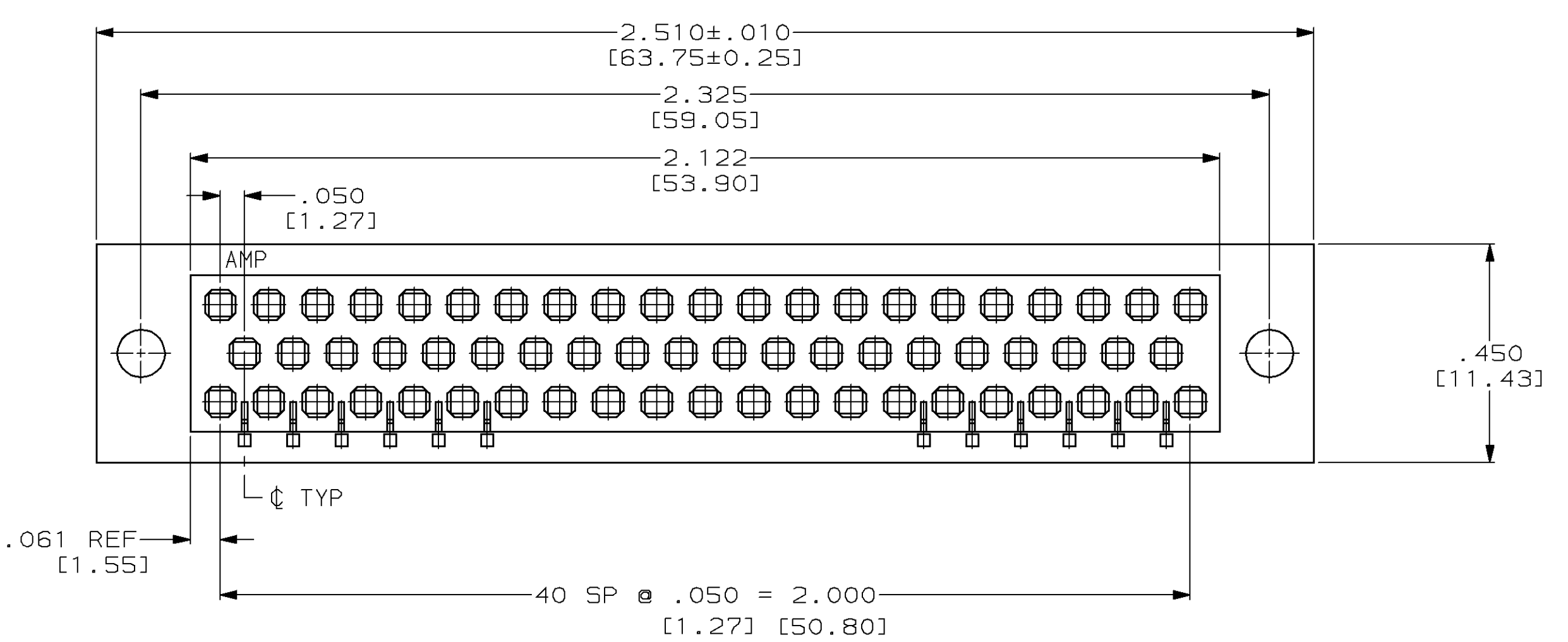
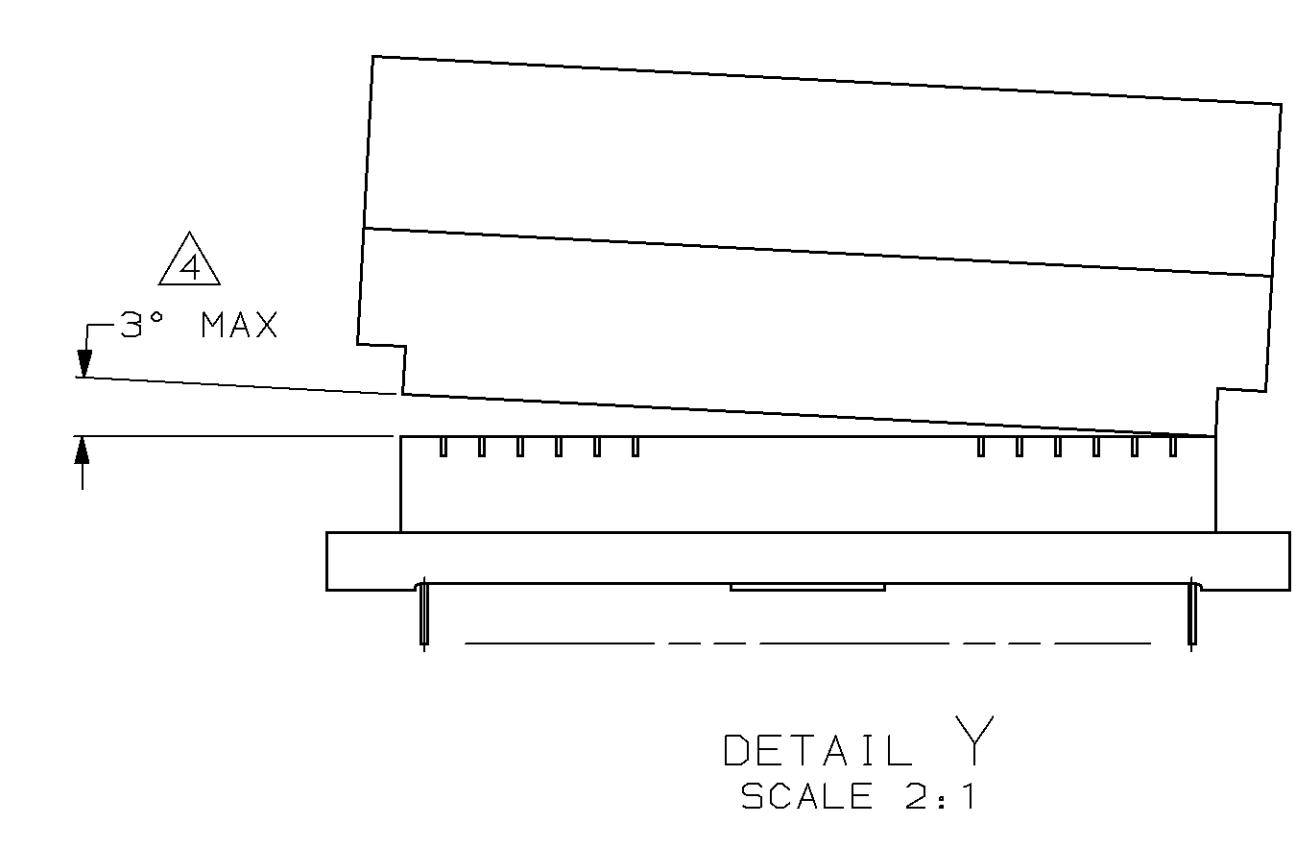
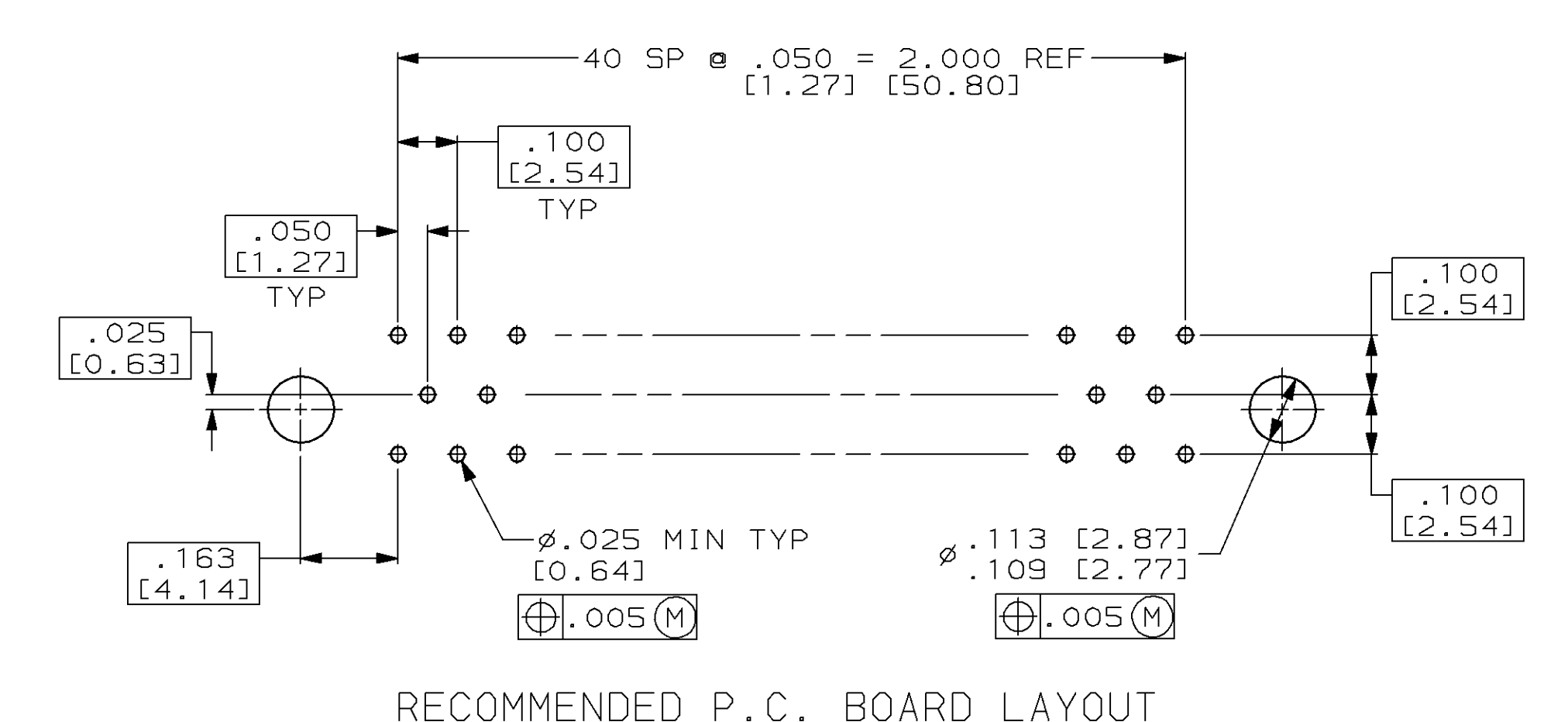
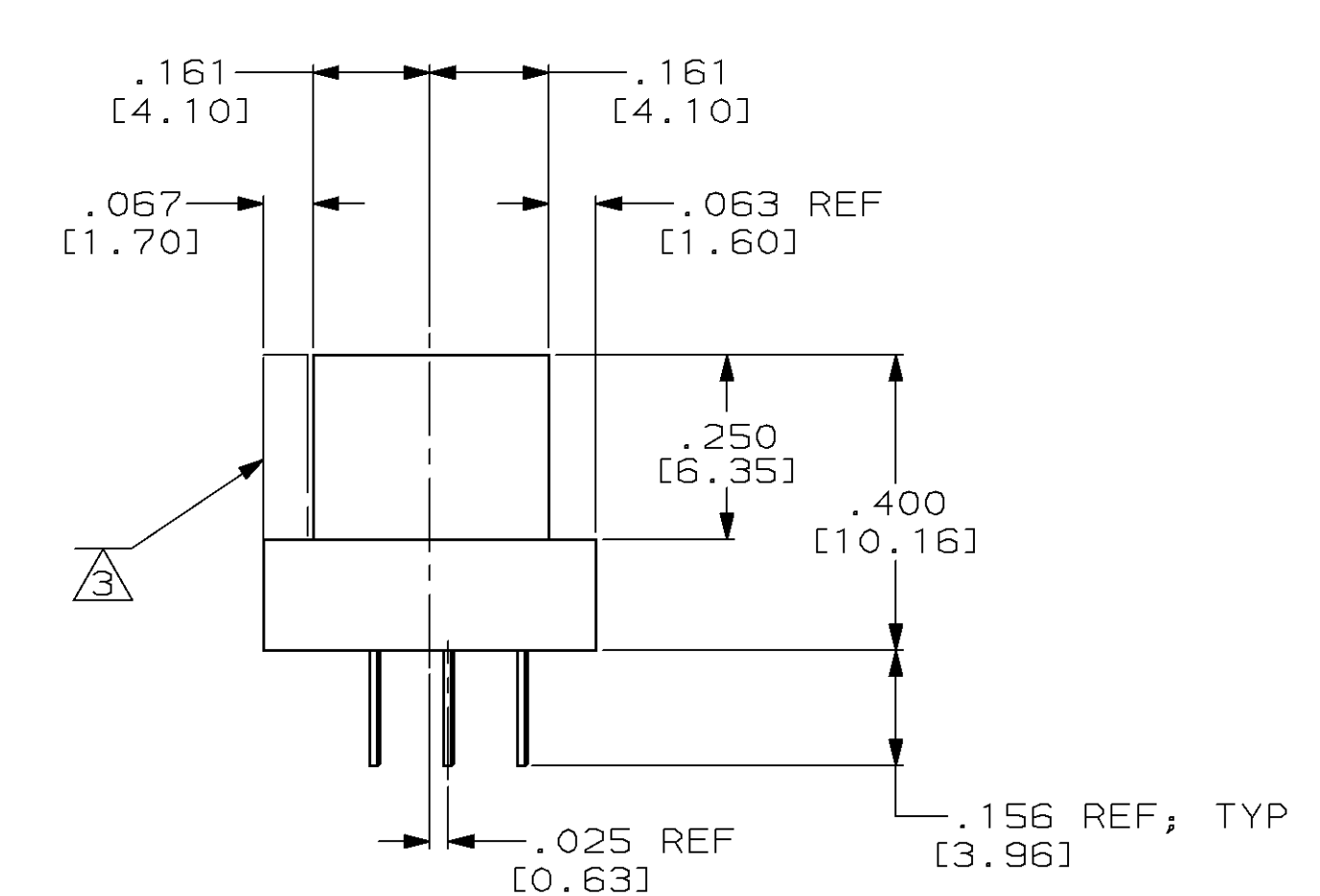
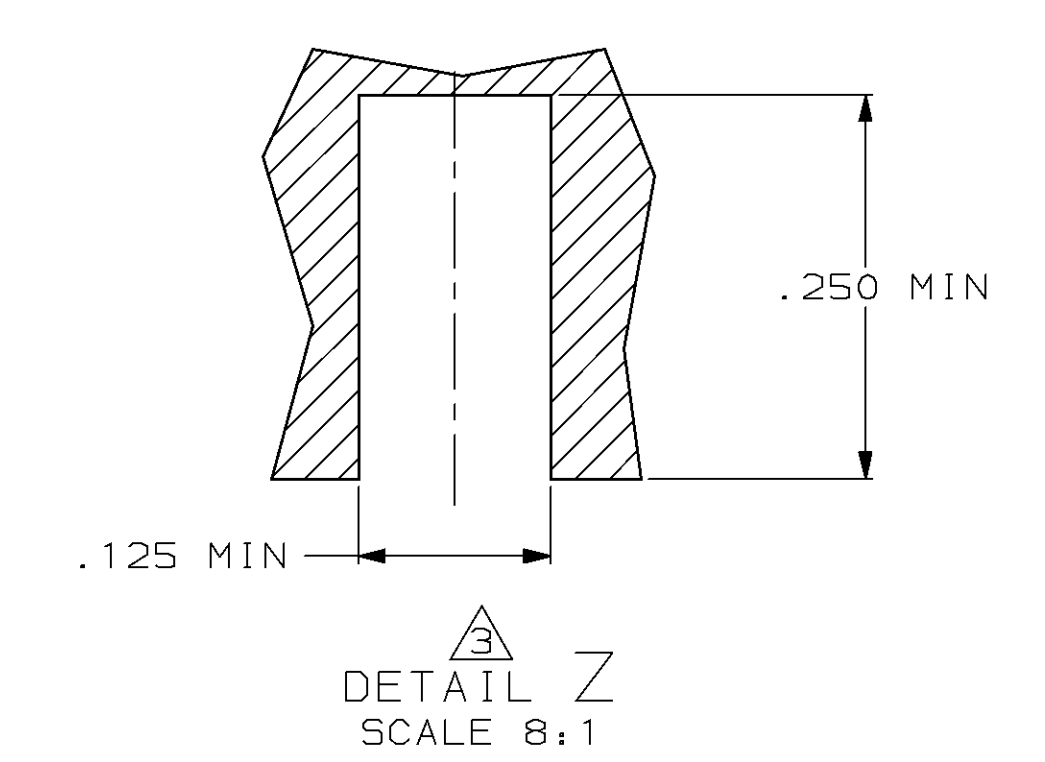
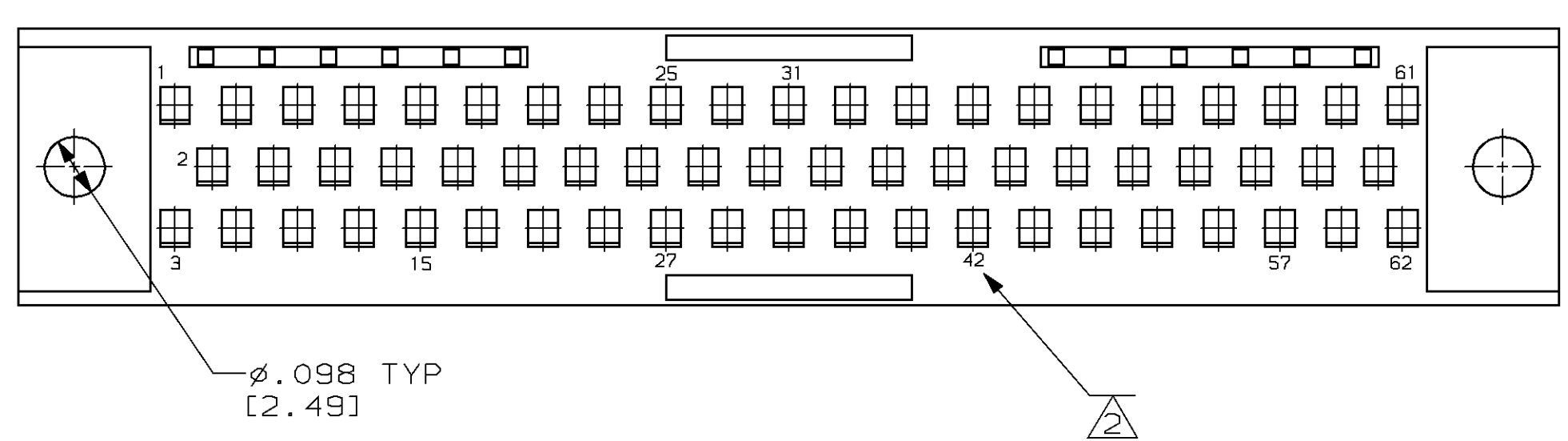

- 1 AMP, AMP PART NO. AND DATE CODE MARKED THIS AREA ON OPPOSITE SIDE.
- 2 CONTACT NUMBERS MOLDED ON THIS SURFACE AS SHOWN.
- 3 KEYING INSERT PART NO. 202934-1 SHOWN IN PLACE. PURCHASED SEPARATELY AND INSTALLED BY CUSTOMER AS REQUIRED. FOR KEYING SLOT DIMENSION, (DAUGHTER CARD), SEE DETAIL Z.
- 4 THESE CONNECTORS TO BE USED WITH CARD GUIDES ONLY, CONNECTOR ENTRY ANGLE PERMISSABLE TO 3° MAX. SEE DETAIL Y.
5. A MINIMUM OF (1) ONE KEY MUST BE USED WITH THIS ASSEMBLY TO PROVIDE POLARIZATION FEATURE.
- 6 .000100 [0.0025] MIN SOLDER DIP .050 [1.27] MAX FROM HOUSING AS SHOWN.

DO NOT SCALE PRINT. UNLESS SPECIFIED DIMENSIONS IN INCHES [mm]		DR 11-14-90 C.C. THOMAS		62 447262-1	
TOLERANCES ON:		CHK -		NO. OF POSN.	
2 PLC DEC ±		APPD -		PART NO.	
3 PLC DEC ± .005 (0.13)		APPD -		AMP Incorporated	
ANGLES ±		APPD -		Harrisburg, PA 17105-3608	
MATERIAL		PRODUCT SPEC		NAME	
SEE CALLOUTS		-		RCPT. ASSY, 1001 SERIES BOX	
FINISH		APPLICATION SPEC		WITH SOLDER DIPPED CONTACTS	
SEE CALLOUTS		-		SIZE	
		WEIGHT		CAGE CODE	
		-		D 00779	
		SCALE		DRAWING NO	
		4:1		447262	
				SHEET	
				1 OF 1	