

Programmable Timing Control Hub™ for Mobile P4™ Systems

Recommended Application:

CK410M Compliant Main Clock

Output Features:

- 2 - 0.7V current-mode differential CPU pairs
- 4 - 0.7V current-mode differential PCI Express* pairs
- 1 - 0.7V current-mode differential CPU/PCI Express selectable pair
- 1 - 0.7V current-mode differential SATA pair
- 1 - 0.7V current-mode differential LCDCLK/PCI Express selectable pair
- 4 - PCI (33MHz)
- 2 - PCICLK_F, (33MHz) free-running
- 1 - USB, 48MHz
- 1 - DOT, 96MHz, 0.7V current differential pair
- 2 - REF, 14.318MHz

Key Specifications:

- CPU outputs cycle-cycle jitter < 85ps
- PCI Express outputs cycle-cycle jitter < 125ps
- SATA outputs cycle-cycle jitter < 125ps
- PCI outputs cycle-cycle jitter < 500ps
- +/- 300ppm frequency accuracy on CPU, PCI Express and SATA clocks
- +/- 100ppm frequency accuracy on USB clocks

Features/Benefits:

- Supports tight ppm accuracy clocks for Serial-ATA and PCI Express
- Supports programmable spread percentage and frequency
- Uses external 14.318MHz crystal, external crystal load caps are required for frequency tuning
- Supports undriven differential CPU, PCI Express pair in PD for power management.
- PEREQ# pins to support PCI Express and SATA power management.

Pin Configuration

VDDPCI	1	56	PCICLK2/REQ_SEL**
GND	2	55	PCI/SRC_STOP#
PCICLK3	3	54	CPU_STOP#
PCICLK4	4	53	REF1/FS_C/TEST_SEL
PCICLK5	5	52	REF0
GND	6	51	GND
VDDPCI	7	50	X1
ITP_EN/PCICLK_F0	8	49	X2
*SELPCIEX_LCDCLK#/PCICLK_F1	9	48	VDDREF
Vtt_PwrGd#/PD	10	47	SDATA
VDD48	11	46	SCLK
FS_A/USB_48MHz	12	45	GND
GND	13	44	CPUCLKT0
DOTT_96MHz	14	43	CPUCLKC0
DOTC_96MHz	15	42	VDDCPU
FS_B/TEST_MODE	16	41	CPUCLKT1
LCDCLK_SS/PCIEX0T	17	40	CPUCLKC1
LCDCLK_SS/PCIEX0C	18	39	IREF
PCIEXT1	19	38	GND
PCIEXC1	20	37	VDDA
VDDPCIEX	21	36	CPUCLKT2_ITP/PCIEXT6
PCIEXT2	22	35	CPUCLKC2_ITP/PCIEXC6
PCIEXC2	23	34	VDDPCIEX
PCIEXT3	24	33	PEREQ1#*/PCIEXT5
PCIEXC3	25	32	PEREQ2#*/PCIEXC5
SATACLKT	26	31	PCIEXT4
SATACLKC	27	30	PCIEXC4
VDDPCIEX	28	29	GND

56-pin SSOP & TSSOP

* Internal Pull-Up Resistor

** Internal Pull-Down Resistor

Table 1: Frequency Selection Table

FS ₁ C B6b2	FS ₁ B B6b1	FS ₁ A B6b0	CPU MHz	PCIEX MHz	PCI MHz	REF MHz	USB MHz	DOT MHz	Spread %
0	0	0	266.66	100.00	33.33	14.318	48.00	96.00	0.5% Down
0	0	1	133.33	100.00	33.33	14.318	48.00	96.00	0.5% Down
0	1	0	200.00	100.00	33.33	14.318	48.00	96.00	0.5% Down
0	1	1	166.66	100.00	33.33	14.318	48.00	96.00	0.5% Down
1	0	0	333.33	100.00	33.33	14.318	48.00	96.00	0.5% Down
1	0	1	100.00	100.00	33.33	14.318	48.00	96.00	0.5% Down
1	1	0	400.00	100.00	33.33	14.318	48.00	96.00	0.5% Down
1	1	1	200.00	100.00	33.33	14.318	48.00	96.00	0.5% Down

Pin Description

PIN #	PIN NAME	TYPE	DESCRIPTION
1	VDDPCI	PWR	Power supply for PCI clocks, nominal 3.3V
2	GND	PWR	Ground pin.
3	PCICLK3	OUT	PCI clock output.
4	PCICLK4	OUT	PCI clock output.
5	PCICLK5	OUT	PCI clock output.
6	GND	PWR	Ground pin.
7	VDDPCI	PWR	Power supply for PCI clocks, nominal 3.3V
8	ITP_EN/PCICLK_F0	I/O	Free running PCI clock not affected by PCI_STOP# through I2C . ITP_EN: latched input to select pin functionality 1 = CPU_2_ITP pair 0 = PCIEX_6 pair
9	*SELPCIEX_LCDCLK#/PCI_CLK_F1	I/O	Latched select input for LCDCLK/PCIEX output 0 = LCDCLK, 1 = PCIEX / Free running 3.3V PCI clock output.
10	Vtt_PwrGd#/PD	IN	Vtt_PwrGd# is an active low input used to determine when latched inputs are ready to be sampled. PD is an asynchronous active high input pin used to put the device into a low power state. The internal clocks, PLLs and the crystal oscillator are stopped.
11	VDD48	PWR	Power pin for the 48MHz output.3.3V
12	FSLA/USB_48MHz	I/O	3.3V tolerant input for CPU frequency selection. Refer to input electrical characteristics for Vil_FS and Vih_FS values. / Fixed 48MHz USB clock output. 3.3V.
13	GND	PWR	Ground pin.
14	DOTT_96MHz	OUT	True clock of differential pair for 96.00MHz DOT clock.
15	DOTC_96MHz	OUT	Complement clock of differential pair for 96.00MHz DOT clock.
16	FSLB/TEST_MODE	IN	3.3V tolerant input for CPU frequency selection. Refer to input electrical characteristics for Vil_FS and Vih_FS values. TEST_MODE is a real time input to select between Hi-Z and REF/N divider mode while in test mode. Refer to Test Clarification Table.
17	LCDCLK_SS/PCIEX0T	OUT	True clock of LCDCLK_SS output / True clock of PCI Express differential pair. Selected by SELPCIEX_LCDCLK#
18	LCDCLK_SS/PCIEX0C	OUT	Complementary clock of LCDCLK_SS output / Complementary clock of PCI Express differential pair. Selected by SELPCIEX_LCDCLK#
19	PCIEXT1	OUT	True clock of differential PCI_Express pair.
20	PCIEXC1	OUT	Complement clock of differential PCI_Express pair.
21	VDDPCIEX	PWR	Power supply for PCI Express clocks, nominal 3.3V
22	PCIEXT2	OUT	True clock of differential PCI_Express pair.
23	PCIEXC2	OUT	Complement clock of differential PCI_Express pair.
24	PCIEXT3	OUT	True clock of differential PCI_Express pair.
25	PCIEXC3	OUT	Complement clock of differential PCI_Express pair.
26	SATACLKT	OUT	True clock of differential SATA pair.
27	SATACLKC	OUT	Complement clock of differential SATA pair.
28	VDDPCIEX	PWR	Power supply for PCI Express clocks, nominal 3.3V

Pin Description (Continued)

PIN #	PIN NAME	TYPE	DESCRIPTION
29	GND	PWR	Ground pin.
30	PCIEXC4	OUT	Complement clock of differential PCI_Express pair.
31	PCIEXT4	OUT	True clock of differential PCI_Express pair.
32	PEREQ2#/PCIEXC5	I/O	Real-time input pin that controls SATACLK and PCIEXCLK outputs that are selected through the I2c. 1 = disabled, 0 = enabled. / Complement clock of differential PCI Express output.
33	PEREQ1#/PCIEXT5	I/O	Real-time input pin that controls SATACLK and PCIEXCLK outputs that are selected through the I2c. 1 = disabled, 0 = enabled. / True clock of differential PCI Express output.
34	VDDPCIEX	PWR	Power supply for PCI Express clocks, nominal 3.3V
35	CPUCLKC2_ITP/PCIEXC6	OUT	Complimentary clock of CPU_ITP/PCIEX differential pair CPU_ITP/PCIEX output. These are current mode outputs. External resistors are required for voltage bias. Selected by ITP_EN input.
36	CPUCLKT2_ITP/PCIEXT6	OUT	True clock of differential pair CPU outputs. These are current mode outputs. External resistors are required for voltage bias. / True clock of differential PCIEX pair
37	VDDA	PWR	3.3V power for the PLL core.
38	GND A	PWR	Ground pin for the PLL core.
39	IREF	OUT	This pin establishes the reference current for the differential current-mode output pairs. This pin requires a fixed precision resistor tied to ground in order to establish the appropriate current. 475 ohms is the standard value.
40	CPUCLKC1	OUT	Complimentary clock of differential pair CPU outputs. These are current mode outputs. External resistors are required for voltage bias.
41	CPUCLKT1	OUT	True clock of differential pair CPU outputs. These are current mode outputs. External resistors are required for voltage bias.
42	VDDCPU	PWR	Supply for CPU clocks, 3.3V nominal
43	CPUCLKC0	OUT	Complimentary clock of differential pair CPU outputs. These are current mode outputs. External resistors are required for voltage bias.
44	CPUCLKT0	OUT	True clock of differential pair CPU outputs. These are current mode outputs. External resistors are required for voltage bias.
45	GND	PWR	Ground pin.
46	SCLK	IN	Clock pin of SMBus circuitry, 5V tolerant.
47	SDATA	I/O	Data pin for SMBus circuitry, 5V tolerant.
48	VDDREF	PWR	Ref, XTAL power supply, nominal 3.3V
49	X2	OUT	Crystal output, Nominally 14.318MHz
50	X1	IN	Crystal input, Nominally 14.318MHz.
51	GND	PWR	Ground pin.
52	REF0	OUT	14.318 MHz reference clock.
53	REF1/FSLC/TEST_SEL	I/O	14.318 MHz reference clock./ 3.3V tolerant input for CPU frequency selection. Refer to input electrical characteristics for Vil_FS and Vih_FS values. /TEST_Sel: 3-level latched input to enable test mode. Refer to Test Clarification Table
54	CPU_STOP#	IN	Stops all CPUCLK, except those set to be free running clocks
55	PCI/SRC_STOP#	IN	Stops all PCICLKs and SRCCLKs besides the free-running clocks at logic 0 level, when input low
56	PCICLK2/REQ_SEL**	I/O	3.3V PCI clock output / Latch select input pin. 0 = PCIEXCLK5 1 = PEREQ

General Description

ICS954206B is a CK410M Compliant clock synthesizer. **ICS954206B** provides a single-chip solution for mobile systems built with Intel P4-M processors and Intel mobile chipsets. **ICS954206B** is driven with a 14.318MHz crystal and generates CPU outputs up to 400MHz. It provides the tight ppm accuracy required by Serial ATA and PCI Express.

Block Diagram

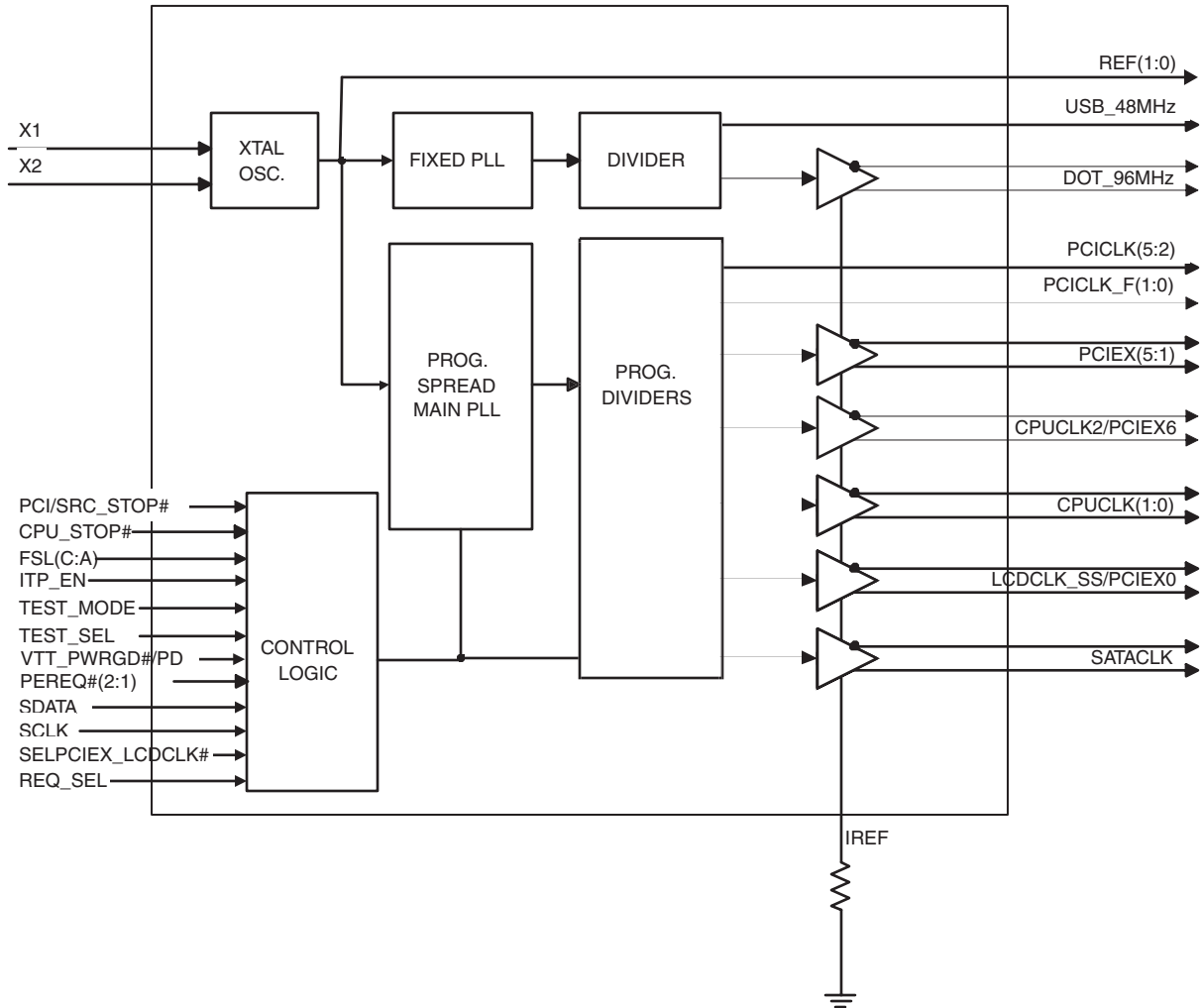

General SMBus serial interface information for the ICS954206B

How to Write:

- Controller (host) sends a start bit.
- Controller (host) sends the write address $D2_{(H)}$
- ICS clock will **acknowledge**
- Controller (host) sends the beginning byte location = N
- ICS clock will **acknowledge**
- Controller (host) sends the data byte count = X
- ICS clock will **acknowledge**
- Controller (host) starts sending **Byte N through Byte N + X - 1**
(see Note 2)
- ICS clock will **acknowledge** each byte **one at a time**
- Controller (host) sends a Stop bit

Index Block Write Operation		
Controller (Host)		ICS (Slave/Receiver)
T	starT bit	
Slave Address $D2_{(H)}$		
WR	WRite	
		ACK
Beginning Byte = N		
		ACK
Data Byte Count = X		
		ACK
Beginning Byte N		X Byte
○		
○		
○		
Byte N + X - 1		
		ACK
P	stoP bit	

How to Read:

- Controller (host) will send start bit.
- Controller (host) sends the write address $D2_{(H)}$
- ICS clock will **acknowledge**
- Controller (host) sends the beginning byte location = N
- ICS clock will **acknowledge**
- Controller (host) will send a separate start bit.
- Controller (host) sends the read address $D3_{(H)}$
- ICS clock will **acknowledge**
- ICS clock will send the data byte count = X
- ICS clock sends **Byte N + X - 1**
- ICS clock sends **Byte 0 through byte X (if $X_{(H)}$ was written to byte 8)**.
- Controller (host) will need to acknowledge each byte
- Controller (host) will send a not acknowledge bit
- Controller (host) will send a stop bit

Index Block Read Operation		
Controller (Host)		ICS (Slave/Receiver)
T	starT bit	
Slave Address $D2_{(H)}$		
WR	WRite	
		ACK
Beginning Byte = N		
		ACK
RT	Repeat starT	
Slave Address $D3_{(H)}$		
RD	ReaD	
		ACK
		Data Byte Count = X
ACK		
ACK		X Byte
○		
○		
○		
		Byte N + X - 1
N	Not acknowledge	
P	stoP bit	



Table2: LCDCLK Spread and Frequency Selection Table

Byte 6b7	Byte 6b6	Byte 6b5	Byte 6b4	Byte 6b3	Pin 17/18	Spread
					MHz	%
0	0	0	0	0	96.00	0.8 Down
0	0	0	0	1	96.00	1 Down
0	0	0	1	0	96.00	1.25 Down
0	0	0	1	1	96.00	1.5 Down
0	0	1	0	0	96.00	1.75 Down
0	0	1	0	1	96.00	2 Down
0	0	1	1	0	96.00	2.5 Down
0	0	1	1	1	96.00	3 Down
0	1	0	0	0	96.00	+/-0.3 Center
0	1	0	0	1	96.00	+/-0.4 Center
0	1	0	1	0	96.00	+/-0.5 Center
0	1	0	1	1	96.00	+/-0.6 Center
0	1	1	0	0	96.00	+/-0.8 Center
0	1	1	0	1	96.00	+/-1.0 Center
0	1	1	1	0	96.00	+/-1.25 Center
0	1	1	1	1	96.00	+/-1.5 Center
1	0	0	0	0	100.00	0.8 Down
1	0	0	0	1	100.00	1 Down
1	0	0	1	0	100.00	1.25 Down
1	0	0	1	1	100.00	1.5 Down
1	0	1	0	0	100.00	1.75 Down
1	0	1	0	1	100.00	2 Down
1	0	1	1	0	100.00	2.5 Down
1	0	1	1	1	100.00	3 Down
1	1	0	0	0	100.00	+/-0.3 Center
1	1	0	0	1	100.00	+/-0.4 Center
1	1	0	1	0	100.00	+/-0.5 Center
1	1	0	1	1	100.00	+/-0.6 Center
1	1	1	0	0	100.00	+/-0.8 Center
1	1	1	0	1	100.00	+/-1.0 Center
1	1	1	1	0	100.00	+/-1.25 Center
1	1	1	1	1	100.00	+/-1.5 Center

Absolute Maximum Rating

PARAMETER	SYMBOL	CONDITIONS	MIN	TYP	MAX	UNITS	Notes
3.3V Core Supply Voltage	VDD_A	-			V _{DD} + 0.5V	V	1
3.3V Logic Input Supply Voltage	VDD_In	-	GND - 0.5		V _{DD} + 0.5V	V	1
Storage Temperature	T _s	-	-65		150	°C	1
Ambient Operating Temp	T _{ambient}	-	0		70	°C	1
Case Temperature	T _{case}	-			115	°C	1
Input ESD protection HBM	ESD prot	-	2000			V	1

¹Guaranteed by design and characterization, not 100% tested in production.

Electrical Characteristics - Input/Supply/Common Output Parameters

PARAMETER	SYMBOL	CONDITIONS*	MIN	TYP	MAX	UNITS	Notes
Input High Voltage	V _{IH}	3.3 V +/-5%	2		V _{DD} + 0.3	V	1
Input Low Voltage	V _{IL}	3.3 V +/-5%	V _{SS} - 0.3		0.8	V	1
Input High Current	I _{IH}	V _{IN} = V _{DD}	-5		5	uA	1
Input Low Current	I _{IL1}	V _{IN} = 0 V; Inputs with no pull-up resistors	-5			uA	1
	I _{IL2}	V _{IN} = 0 V; Inputs with pull-up resistors	-200			uA	1
Low Threshold Input-High Voltage	V _{IH_FS}	3.3 V +/-5%	0.7		V _{DD} + 0.3	V	1
Low Threshold Input-Low Voltage	V _{IL_FS}	3.3 V +/-5%	V _{SS} - 0.3		0.35	V	1
Operating Supply Current	I _{DD3.3OP}	Full Active, C _L = Full load;			350	mA	1
Operating Current	I _{DD3.3OP}	all outputs driven			400	mA	1
		all diff pairs driven			70	mA	1
Powerdown Current	I _{DD3.3PD}	all differential pairs tri-stated			12	mA	1
Input Frequency	F _i	V _{DD} = 3.3 V		14.31818		MHz	2
Pin Inductance	L _{pin}				7	nH	1
Input Capacitance	C _{IN}	Logic Inputs			5	pF	1
	C _{OUT}	Output pin capacitance			6	pF	1
	C _{INX}	X1 & X2 pins			5	pF	1
Clk Stabilization	T _{STAB}	From VDD Power-Up or de-assertion of PD to 1st clock			1.8	ms	1
Modulation Frequency		Triangular Modulation	30		33	kHz	1
Tdrive_PD		CPU output enable after PD de-assertion			300	us	1
Tfall_PD		PD fall time of			5	ns	1
Trise_PD		PD rise time of			5	ns	1
SMBus Voltage	V _{DD}		2.7		5.5	V	1
Low-level Output Voltage	V _{OL}	@ I _{PULLUP}			0.4	V	1
Current sinking at V _{OL} = 0.4 V	I _{PULLUP}		4			mA	1
SCLK/SDATA Clock/Data Rise Time	T _{R12C}	(Max VIL - 0.15) to (Min VIH + 0.15)			1000	ns	1
SCLK/SDATA Clock/Data Fall Time	T _{F12C}	(Min VIH + 0.15) to (Max VIL - 0.15)			300	ns	1

*TA = 0 - 70°C; Supply Voltage VDD = 3.3 V +/-5%

¹Guaranteed by design and characterization, not 100% tested in production.

²Input frequency should be measured at the REF pin and tuned to ideal 14.31818MHz to meet ppm frequency accuracy on PLL outputs.

Electrical Characteristics - CPU 0.7V Current Mode Differential Pair

PARAMETER	SYMBOL	CONDITIONS*	MIN	TYP	MAX	UNITS	NOTES
Current Source Output Impedance	Zo	$V_O = V_x$	3000			Ω	1
Voltage High	VHigh	Statistical measurement on single ended signal	660		850	mV	1,3
Voltage Low	VLow		-150		150	mV	1,3
Max Voltage	Vovs	Measurement on single ended signal using absolute value.			1150	mV	1
Min Voltage	Vuds		-300			mV	1
Crossing Voltage (abs)	Vx(abs)		250		550	mV	1
Crossing Voltage (var)	d-Vx	Variation of crossing over all edges			140	mV	1
Long Accuracy	ppm	see Tperiod min-max values	-300		300	ppm	1,2
Average period	Tperiod	400MHz nominal	2.4993		2.5008	ns	2
		400MHz spread	2.4993		2.5133	ns	2
		333.33MHz nominal	2.9991		3.0009	ns	2
		333.33MHz spread	2.9991		3.016	ns	2
		266.66MHz nominal	3.7489		3.7511	ns	2
		266.66MHz spread	3.7489		3.77	ns	2
		200MHz nominal	4.9985		5.0015	ns	2
		200MHz spread	4.9985		5.0266	ns	2
		166.66MHz nominal	5.9982		6.0018	ns	2
		166.66MHz spread	5.9982		6.0320	ns	2
		133.33MHz nominal	7.4978		7.5023	ns	2
		133.33MHz spread	7.4978		7.5400	ns	2
		100.00MHz nominal	9.9970		10.0030	ns	2
		100.00MHz spread	9.9970		10.0533	ns	2
Absolute min period	T _{absmin}	400MHz nominal/spread	2.4143			ns	1,2
		333.33MHz nominal/spread	2.9141			ns	1,2
		266.66MHz nominal/spread	3.6639			ns	1,2
		200MHz nominal/spread	4.8735			ns	1,2
		166.66MHz nominal/spread	5.8732			ns	1,2
		133.33MHz nominal/spread	7.3728			ns	1,2
		100.00MHz nominal/spread	9.8720			ns	1,2
Rise Time	t _r	$V_{OL} = 0.175V, V_{OH} = 0.525V$	175		700	ps	1
Fall Time	t _f	$V_{OH} = 0.525V, V_{OL} = 0.175V$	175		700	ps	1
Rise Time Variation	d-t _r	$V_{OL} = 0.175V, V_{OH} = 0.525V$			125	ps	1
Fall Time Variation	d-t _f	$V_{OH} = 0.525V, V_{OL} = 0.175V$			125	ps	1
Duty Cycle	d ₁₃	Measurement from differential waveform	45		55	%	1
Skew	t _{sk3}	CPU(1:0), V _T = 50%			100	ps	1
Skew	t _{sk4}	CPU(1:0) to CPU2_ITP, V _T = 50%			150	ps	1
Jitter, Cycle to cycle	t _{jcy-cyc}	Measurement from differential waveform from (CPU2_ITP)			125	ps	1
Jitter, Cycle to cycle	t _{jcy-cyc}	Measurement from differential waveform, (CPU(1:0))			85	ps	1

*T_A = 0 - 70°C; V_{DD} = 3.3 V +/-5%; C_L = 2pF, R_S = 33.2 Ω , R_P = 49.9 Ω , I_{REF} = 475 Ω

¹Guaranteed by design and characterization, not 100% tested in production.

²All Long Term Accuracy and Clock Period specifications are guaranteed assuming that REFOUT is at 14.31818MHz

³I_{REF} = V_{DD}/(3xR_R). For R_R = 475 Ω (1%), I_{REF} = 2.32mA. I_{OH} = 6 x I_{REF} and V_{OH} = 0.7V @ Z_O = 50 Ω .

Electrical Characteristics - SRC/SATA/PCIEX 0.7V Current Mode Differential Pair

PARAMETER	SYMBOL	CONDITIONS*	MIN	TYP	MAX	UNITS	Notes
Current Source Output Impedance	Zo	$V_O = V_x$	3000			Ω	1
Voltage High	VHigh	Statistical measurement on single ended signal	660		850	mV	1,3
Voltage Low	VLow		-150		150	mV	1,3
Max Voltage	Vovs	Measurement on single ended signal using absolute value.			1150	mV	1
Min Voltage	Vuds		-300			mV	1
Crossing Voltage (abs)	Vx(abs)		250		550	mV	1
Crossing Voltage (var)	d-Vx	Variation of crossing over all edges			140	mV	1
Long Accuracy	ppm	see Tperiod min-max values	-300		300	ppm	1,2
Average period	Tperiod	100.00MHz nominal	9.9970		10.0030	ns	2
		100.00MHz spread	9.9970		10.0533	ns	2
Absolute min period	Tabsmín	100.00MHz nominal/spread	9.8720			ns	1,2
Rise Time	t _r	$V_{OL} = 0.175V, V_{OH} = 0.525V$	175		700	ps	1
Fall Time	t _f	$V_{OH} = 0.525V, V_{OL} = 0.175V$	175		700	ps	1
Rise Time Variation	d-t _r	$V_{OL} = 0.175V, V_{OH} = 0.525V$			125	ps	1
Fall Time Variation	d-t _f	$V_{OH} = 0.525V, V_{OL} = 0.175V$			125	ps	1
Duty Cycle	d ₁₃	Measurement from differential waveform	45		55	%	1
Skew	t _{sk3}	$V_T = 50\%$			250	ps	1
Jitter, Cycle to cycle	t _{jcy-cyc}	Measurement from differential waveform			125	ps	1

*T_A = 0 - 70°C; V_{DD} = 3.3 V +/-5%; C_L = 2pF, R_S = 33.2Ω, R_P = 49.9Ω, I_{REF} = 475Ω

¹Guaranteed by design and characterization, not 100% tested in production.

²All Long Term Accuracy and Clock Period specifications are guaranteed assuming that REFOUT is at 14.31818MHz

³I_{REF} = V_{DD}/(3xR_R). For R_R = 475Ω (1%), I_{REF} = 2.32mA. I_{OH} = 6 x I_{REF} and V_{OH} = 0.7V @ Z_O = 50Ω.

Electrical Characteristics - PCICLK/PCICLK_F

PARAMETER	SYMBOL	CONDITIONS*	MIN	TYP	MAX	UNITS	NOTES
Output Impedance	R _{DSP}	$V_O = V_{DD}*(0.5)$	12		55	Ω	1
Output High Voltage	V _{OH}	I _{OH} = -1 mA	2.4			V	1
Output Low Voltage	V _{OL}	I _{OL} = 1 mA			0.55	V	1
Output High Current	I _{OH}	V _{OH} @ MIN = 1.0 V	-33			mA	1
		V _{OH} @ MAX = 3.135 V			-33	mA	1
Output Low Current	I _{OL}	V _{OL} @ MIN = 1.95 V	30			mA	1
		V _{OL} @ MAX = 0.4 V			38	mA	1
Edge Rate	t _{slew/ff}	Rising/Falling edge rate	1		4	V/ns	1
Rise Time	t _r	V _{OL} = 0.4 V, V _{OH} = 2.4 V	0.5		2	ns	1
Fall Time	t _f	V _{OH} = 2.4 V, V _{OL} = 0.4 V	0.5		2	ns	1
Duty Cycle	d _{t1}	V _T = 1.5 V	45		55	%	1
Group Skew	t _{skew}	V _T = 1.5 V			250	ps	1
Jitter, Cycle to cycle	t _{jcy-cyc}	V _T = 1.5 V			500	ps	1

*T_A = 0 - 70°C; Supply Voltage VDD = 3.3 V +/-5%, CL = 20 pF with R_s = 7Ω (unless otherwise specified)

¹Guaranteed by design and characterization, not 100% tested in production.

³Spread Spectrum is off

Electrical Characteristics - 48MHz/USB48MHz/24 48MHz

PARAMETER	SYMBOL	CONDITIONS*	MIN	TYP	MAX	UNITS	NOTES
Long Accuracy	ppm	see Tperiod min-max values	-100		100	ppm	1,2
Clock period	T _{period}	48.00MHz output nominal	20.8313		20.8354	ns	2
Output Impedance	R _{DSP}	V _O = V _{DD} *(0.5)	12		55	Ω	1
Output High Voltage	V _{OH}	I _{OH} = -1 mA	2.4			V	1
Output Low Voltage	V _{OL}	I _{OL} = 1 mA			0.55	V	1
Output High Current	I _{OH}	V _{OH} @ MIN = 1.0 V	-33			mA	1
		V _{OH} @ MAX = 3.135 V			-33	mA	1
Output Low Current	I _{OL}	V _{OL} @ MIN = 1.95 V	30			mA	1
		V _{OL} @ MAX = 0.4 V			38	mA	1
Edge Rate	t _{slewr/f}	Rising/Falling edge rate	1		4	V/ns	1
Edge Rate	t _{slewr/f_USB}	USB48 Rising/Falling edge rate	1		2	V/ns	1
Rise Time	t _r	V _{OL} = 0.4 V, V _{OH} = 2.4 V	0.5		2	ns	1
Fall Time	t _f	V _{OH} = 2.4 V, V _{OL} = 0.4 V	0.5		2	ns	1
Rise Time	t _{r_USB}	V _{OL} = 0.4 V, V _{OH} = 2.4 V	1		2	ns	1
Fall Time	t _{f_USB}	V _{OH} = 2.4 V, V _{OL} = 0.4 V	1		2	ns	1
Duty Cycle	d _{t1}	V _T = 1.5 V	45		55	%	1
Group Skew	t _{skew}	V _T = 1.5 V			250	ps	1
Jitter, Cycle to cycle	t _{jcy-cyc}	V _T = 1.5 V			500	ps	1

*TA = 0 - 70°C; Supply Voltage VDD = 3.3 V +/-5%, CL = 20 pF with Rs = 7Ω (Rs is used in USB48MHz test only)

¹Guaranteed by design and characterization, not 100% tested in production.

Electrical Characteristics - DOT 96MHz 0.7V Current Mode Differential Pair

PARAMETER	SYMBOL	CONDITIONS*	MIN	TYP	MAX	UNITS	Notes
Current Source Output Impedance	Z _o	V _O = V _x	3000			Ω	1
Voltage High	VHigh	Statistical measurement on single ended signal	660		850	mV	1,3
Voltage Low	VLow		-150		150	mV	1,3
Max Voltage	Vovs	Measurement on single ended signal using absolute value.			1150	mV	1
Min Voltage	Vuds		-300			mV	1
Crossing Voltage (abs)	Vx(abs)		250		550	mV	1
Crossing Voltage (var)	d-Vcross	Variation of crossing over all edges			140	mV	1
Long Accuracy	ppm	see Tperiod min-max values	-100		100	ppm	1,2
Average period	T _{period}	96.00MHz nominal	10.4135		10.4198	ns	2
Absolute min period	T _{absmin}	96.00MHz nominal	10.1635			ns	1,2
Rise Time	t _r	V _{OL} = 0.175V, V _{OH} = 0.525V	175		700	ps	1
Fall Time	t _f	V _{OH} = 0.525V V _{OL} = 0.175V	175		700	ps	1
Rise Time Variation	d-t _r	V _{OL} = 0.175V, V _{OH} = 0.525V			125	ps	1
Fall Time Variation	d-t _f	V _{OH} = 0.525V V _{OL} = 0.175V			125	ps	1
Duty Cycle	d _{i3}	Measurement from differential waveform	45		55	%	1
Jitter, Cycle to cycle	t _{jcy-cyc}	Measurement from differential waveform			250	ps	1

*TA = 0 - 70°C; V_{DD} = 3.3 V +/-5%; C_L = 2pF, R_S = 33.2Ω, R_P = 49.9Ω, I_{REF} = 475Ω

¹Guaranteed by design and characterization, not 100% tested in production.

²All Long Term Accuracy and Clock Period specifications are guaranteed assuming that REFOUT is at 14.31818MHz

³I_{REF} = V_{DD}/(3xR_R). For R_R = 475Ω (1%), I_{REF} = 2.32mA. I_{OH} = 6 x I_{REF} and V_{OH} = 0.7V @ Z_O = 50Ω.

Electrical Characteristics - REF-14.318MHz

PARAMETER	SYMBOL	CONDITIONS	MIN	TYP	MAX	UNITS	Notes
Long Accuracy	ppm	see T _{period} min-max values	-300		300	ppm	1,2
Clock period	T _{period}	14.318MHz output nominal	69.8270		69.8550	ns	2
Output High Voltage	V _{OH}	I _{OH} = -1 mA	2.4			V	1
Output Low Voltage	V _{OL}	I _{OL} = 1 mA			0.4	V	1
Output High Current	I _{OH}	V _{OH} @MIN = 1.0 V, V _{OH} @MAX = 3.135 V	-29		-23	mA	1
Output Low Current	I _{OL}	V _{OL} @MIN = 1.95 V, @MAX = 0.4 V	29		27	mA	1
Edge Rate	t _{slewr/f}	Rising/Falling edge rate	1		4	V/ns	1
Rise Time	t _{r1}	V _{OL} = 0.4 V, V _{OH} = 2.4 V	1		2	ns	1
Fall Time	t _{f1}	V _{OH} = 2.4 V, V _{OL} = 0.4 V	1		2	ns	1
Skew	t _{sk1}	V _T = 1.5 V			500	ps	1
Duty Cycle	d _{t1}	V _T = 1.5 V	45		55	%	1
Jitter	t _{jyc-cyc}	V _T = 1.5 V			1000	ps	1

*TA = 0 - 70°C; Supply Voltage VDD = 3.3 V +/-5%, CL = 20 pF with Rs = 7Ω (Rs is used in USB48MHz test only)

¹Guaranteed by design and characterization, not 100% tested in production.

²All Long Term Accuracy and Clock Period specifications are guaranteed assuming that REFOUT is at 14.31818MHz

TYPICAL CHARACTERISTICS
SUBJECT TO CHANGE WITHOUT FULL PRODUCT CHARACTERIZATION



I²C Table: Output Control Register

Byte 0	Pin #	Name	Control	Type	0	1	PWD
			Function				
Bit 7	-	CPUCLK2_ITP/PCIEX6 Enable	Output Enable	RW	Disable	Enable	1
Bit 6	-	PCIEX5 Enable	Output Enable	RW	Disable	Enable	1
Bit 5	-	PCIEX4 Enable	Output Enable	RW	Disable	Enable	1
Bit 4	-	SATACLK Enable	Output Enable	RW	Disable	Enable	1
Bit 3	-	PCIEX3 Enable	Output Enable	RW	Disable	Enable	1
Bit 2	-	PCIEX2 Enable	Output Enable	RW	Disable	Enable	1
Bit 1	-	PCIEX1 Enable	Output Enable	RW	Disable	Enable	1
Bit 0	-	LCDCLK/PCIEX0 Enable	Output Enable	RW	Disable	Enable	1

I²C Table: Spread and Output Control Register

Byte 1	Pin #	Name	Control	Type	0	1	PWD
			Function				
Bit 7	-	Test Clock Mode Entry	Test Mode	RW	Disable	Enable	0
Bit 6	-	DOT_96MHz Enable	Output Enable	RW	Disable	Enable	1
Bit 5	-	USB_48MHz Enable	Output Enable	RW	Disable	Enable	1
Bit 4	-	REF_0 Enable	Output Enable	RW	Disable	Enable	1
Bit 3	-	LCDCLK/PCIEX0 Spectrum Mode	Spread Control	RW	OFF	ON	1
Bit 2	-	CPUCLK1	Output Enable	RW	Disable	Enable	1
Bit 1	-	CPUCLK0	Output Enable	RW	Disable	Enable	1
Bit 0	-	Spread Spectrum Mode	Spread Control for PLL1	RW	OFF	ON	0

I²C Table: Output Control Register

Byte 2	Pin #	Name	Control	Type	0	1	PWD
			Function				
Bit 7	-	PCICLK5	Output Enable	RW	Disable	Enable	1
Bit 6	-	PCICLK4	Output Enable	RW	Disable	Enable	1
Bit 5	-	PCICLK3	Output Enable	RW	Disable	Enable	1
Bit 4	-	PCICLK2	Output Enable	RW	Disable	Enable	1
Bit 3	-	Test Mode Selection	Test Mode Selection	RW	Hi-Z	REF/N	0
Bit 2	-	PCI_STOP	Stop all PCI, PCIEX and SATA clocks	RW	Enable	Disable	1
Bit 1	-	PCI_F0 Enable	Output Enable	RW	Disable	Enable	1
Bit 0	-	PCI_F1 Enable	Output Enable	RW	Disable	Enable	1

I²C Table: Output Control Register

Byte 3	Pin #	Name	Control	Type	0	1	PWD
			Function				
Bit 7	-	PCIEX6	Allow assertion of PCI_STOP# or setting of PCI_STOP control bit in SMBus register to stop PCIEX clocks	RW	Free Running	Stoppable	0
Bit 6	-	PCIEX5		RW	Free Running	Stoppable	0
Bit 5	-	PCIEX4		RW	Free Running	Stoppable	0
Bit 4	-	SATACLK		RW	Free Running	Stoppable	0
Bit 3	-	PCIEX3		RW	Free Running	Stoppable	0
Bit 2	-	PCIEX2		RW	Free Running	Stoppable	1
Bit 1	-	PCIEX1		RW	Free Running	Stoppable	1
Bit 0	-	PCIEX0		RW	Free Running	Stoppable	1



IC Table: Output Control Register

Byte 4	Pin #	Name	Control	Type	0	1	PWD
			Function				
Bit 7	-	REF_1 Enable	Output Enable	RW	Disable	Enable	1
Bit 6	-	96MHz	Driven in PD	RW	Driven	Hi-Z	1
Bit 5	-	REF_0 STRENGTH	Strength Programming	RW	1X	2X	1
Bit 4	-	PCI_F1	Allow assertion of	RW	Free Running	Stoppable	1
Bit 3	-	PCI_F0	PCI_STOP# or setting of	RW	Free Running	Stoppable	1
Bit 2	-	CPUCLK2_ITP	Allow assertion of CPU_STOP# to stop CPUCLK outputs	RW	Free Running	Stoppable	1
Bit 1	-	CPUCLK1		RW	Free Running	Stoppable	1
Bit 0	-	CPUCLK0		RW	Free Running	Stoppable	1

IC Table: Output Control Register

Byte 5	Pin #	Name	Control	Type	0	1	PWD
			Function				
Bit 7	-	PCI_STOP Drive Mode	Driven in PCI_STOP#	RW	Driven	Hi-Z	0
Bit 6	-	CPUCLK2_ITP_STOP Drive Mode	Driven in CPU_STOP#	RW	Driven	Hi-Z	0
Bit 5	-	CPUCLK1_STOP Drive Mode		RW	Driven	Hi-Z	0
Bit 4	-	CPUCLK0_STOP Drive Mode		RW	Driven	Hi-Z	0
Bit 3	-	PCIEX (6:0) Drive Mode	Driven in Powerdown (PD)	RW	Driven	Hi-Z	0
Bit 2	-	CPUCLK2_ITP_PD Drive Mode		RW	Driven	Hi-Z	0
Bit 1	-	CPUCLK[1:0] PD Drive Mode		RW	Driven	Hi-Z	0
Bit 0	-	ITP_EN	PCIEX/CPU_ITP select	RW	PCIEX	CPU_ITP	latch

IC Table: Output Control Register

Byte 6	Pin #	Name	Control	Type	0	1	PWD
			Function				
Bit 7	-	SS4	LCDCLK Spread Prog Bit 4	RW	96Mhz	100Mhz	0
Bit 6	-	SS3	LCDCLK Spread Prog Bit 3	RW	See Table 2: LCDCLK Freq Sel		1
Bit 5	-	SS2	LCDCLK Spread Prog Bit 2	RW			0
Bit 4	-	SS1	LCDCLK Spread Prog Bit 1	RW			0
Bit 3	-	SS0	LCDCLK Spread Prog Bit 0	RW			0
Bit 2	-	FSLC	Freq Select Bit 2	RW	See Table 1: PLL1 Frequency Selection Table		Latched
Bit 1	-	FSLB	Freq Select Bit 1	RW			Latched
Bit 0	-	FSLA	Freq Select Bit 0	RW			Latched

IC Table: Vendor & Revision ID Register

Byte 7	Pin #	Name	Control	Type	0	1	PWD
			Function				
Bit 7	-	RID3	REVISION ID	R	-	-	x
Bit 6	-	RID2		R	-	-	x
Bit 5	-	RID1		R	-	-	x
Bit 4	-	RID0		R	-	-	x
Bit 3	-	VID3	VENDOR ID	R	-	-	0
Bit 2	-	VID2		R	-	-	0
Bit 1	-	VID1		R	-	-	0
Bit 0	-	VID0		R	-	-	1



1°C Table: Byte Count Register

Byte 8	Pin #	Name	Control	Type	0	1	PWD
			Function				
Bit 7	-	BC7	Byte Count Programming b(7:0)	RW	Writing to this register will configure how many bytes will be read back, default is 0F = 15 bytes.		0
Bit 6	-	BC6		RW			0
Bit 5	-	BC5		RW			0
Bit 4	-	BC4		RW			0
Bit 3	-	BC3		RW			1
Bit 2	-	BC2		RW			1
Bit 1	-	BC1		RW			1
Bit 0	-	BC0		RW			1

1°C Table: Watchdog Timer Register

Byte 9	Pin #	Name	Control	Type	0	1	PWD
			Function				
Bit 7	-	WDH_EN	Watchdog Hard Alarm Enable	RW	Disable	Enable	0
Bit 6	-	WDS_EN	Watchdog Soft Alarm Enable	RW	Disable	Enable	0
Bit 5	-	WD Hard Status	WD Hard Alarm Status	R	Normal	Alarm	X
Bit 4	-	WD Soft Status	WD Soft Alarm Status	R	Normal	Alarm	X
Bit 3	-	WDTCtrl	Watch Dog Time base Control	RW	290ms Base	1160ms Base	0
Bit 2	-	WD2	WD Timer Bit 2	RW	These bits represent X*290ms (or 1.16S) the watchdog timer waits before it goes to alarm mode. Default is 7 X 290ms = 2s.		1
Bit 1	-	WD1	WD Timer Bit 1	RW			1
Bit 0	-	WD0	WD Timer Bit 0	RW			1

1°C Table: VCO Control Select Bit & WD Timer Control Register

Byte 10	Pin #	Name	Control	Type	0	1	PWD
			Function				
Bit 7	-	M/N_EN	PLL/M/N Programming Enable	RW	Disable	Enable	0
Bit 6	-	LCDCLK/PCIEX0 SEL	SELPCIEX0/LCDCLK#	RW	LCDCLK	PCIEX0	latch
Bit 5	-	REQ_SEL	REQ_SEL	RW	PCIEX5	PEREQ	latch
Bit 4	-	LCDCLK/PCIEX0	Driven in PD	RW	Driven	Hi-Z	0
Bit 3	-	WD Safe Freq Source	WD Safe Freq Source	RW	Latch Inputs/Byte6[2:0]	B10b(2:0)	0
Bit 2	-	WD SFC	Watch Dog Safe Freq Programming bits	RW	Writing to these bit will configure the safe frequency as Byte0 bit (4:0).		0
Bit 1	-	WD SFB		RW			0
Bit 0	-	WD SFA		RW			0

1°C Table: VCO Frequency Control Register

Byte 11	Pin #	Name	Control	Type	0	1	PWD
			Function				
Bit 7	-	N Div8	N Divider Prog bit 8	RW	The decimal representation of M and N Divier in Byte 11 and 12 will configure the VCO frequency. Default at power up = latch-in or Byte 0 Rom table. VCO Frequency = 14.318 x [NDiv(9:0)+8] / [MDiv(5:0)+2]		X
Bit 6	-	N Div 9	N Divider Prog bit 9	RW			X
Bit 5	-	M Div5	M Divider Programming bits	RW			X
Bit 4	-	M Div4		RW			X
Bit 3	-	M Div3		RW			X
Bit 2	-	M Div2		RW			X
Bit 1	-	M Div1		RW			X
Bit 0	-	M Div0		RW			X



²C Table: VCO Frequency Control Register

Byte 12		Pin #	Name	Control Function	Type	0		1		PWD
Bit 7	-		N Div7	N Divider Programming b(8:0)	RW	The decimal representation of M and N Divier in Byte 11 and 12 will configure the VCO frequency. Default at power up = latch-in or Byte 0 Rom table. VCO Frequency = $14.318 \times [\text{NDiv}(9:0)+8] / [\text{MDiv}(5:0)+2]$				X
Bit 6	-		N Div6		RW					X
Bit 5	-		N Div5		RW					X
Bit 4	-		N Div4		RW					X
Bit 3	-		N Div3		RW					X
Bit 2	-		N Div2		RW					X
Bit 1	-		N Div1		RW					X
Bit 0	-		N Div0		RW					X

²C Table: Spread Spectrum Control Register

Byte 13		Pin #	Name	Control Function	Type	0		1		PWD
Bit 7	-		SSP7	Spread Spectrum Programming b(7:0)	RW	These Spread Spectrum bits in Byte 13 and 14 will program the spread percentage. It is recommended to use ICS Spread % table for spread programming.				X
Bit 6	-		SSP6		RW					X
Bit 5	-		SSP5		RW					X
Bit 4	-		SSP4		RW					X
Bit 3	-		SSP3		RW					X
Bit 2	-		SSP2		RW					X
Bit 1	-		SSP1		RW					X
Bit 0	-		SSP0		RW					X

²C Table: Spread Spectrum Control Register

Byte 14		Pin #	Name	Control Function	Type	0		1		PWD
Bit 7	-		Reserved	Reserved	R	-		-		0
Bit 6	-		SSP14	Spread Spectrum Programming b(14:8)	RW	These Spread Spectrum bits in Byte 13 and 14 will program the spread percentage. It is recommended to use ICS Spread % table for spread programming.				X
Bit 5	-		SSP13		RW					X
Bit 4	-		SSP12		RW					X
Bit 3	-		SSP11		RW					X
Bit 2	-		SSP10		RW					X
Bit 1	-		SSP9		RW					X
Bit 0	-		SSP8		RW					X

²C Table: Output Divider Control Register

Byte 15		Pin #	Name	Control Function	Type	0		1		PWD
Bit 7	-		PCIEX Div3	PCIEX Divider Ratio Programming Bits	RW	0000:/2	0100:/4	1000:/8	1100:/16	X
Bit 6	-		PCIEX Div2		RW	0001:/3	0101:/6	1001:/12	1101:/24	X
Bit 5	-		PCIEX Div1		RW	0010:/5	0110:/10	1010:/20	1110:/40	X
Bit 4	-		PCIEX Div0		RW	0011:/15	0111:/30	1011:/60	1111:/120	X
Bit 3	-		CPU Div3	CPUDivider Ratio Programming Bits	RW	0000:/2	0100:/4	1000:/8	1100:/16	X
Bit 2	-		CPU Div2		RW	0001:/3	0101:/6	1001:/12	1101:/24	X
Bit 1	-		CPU Div1		RW	0010:/5	0110:/10	1010:/20	1110:/40	X
Bit 0	-		CPU Div0		RW	0011:/15	0111:/30	1011:/60	1111:/120	X



12C Table: PEREQ# Control Register

Byte 16	Pin #	Name	Control	Type	0	1	PWD
			Function				
Bit 7	-	Reserved	Reserved	RW	-	-	0
Bit 6	-	PEREQ2# controls selected outputs. Outputs controlled by this pin will be Hi-Z when PEREQ2# is high.	SATACLK is controlled	RW	Not Controlled	Controlled	1
Bit 5	-		PCIEX3 is controlled	RW	Not Controlled	Controlled	0
Bit 4	-		PCIEX1 is controlled	RW	Not Controlled	Controlled	0
Bit 3	-	Reserved	Reserved	RW	-	-	0
Bit 2	-	PEREQ1# controls selected outputs. Outputs controlled by this pin will be Hi-Z when PEREQ1# is high.	PCIEX4 is controlled	RW	Not Controlled	Controlled	1
Bit 1	-		PCIEX2 is controlled	RW	Not Controlled	Controlled	0
Bit 0	-		PCIEX0 is controlled	RW	Not Controlled	Controlled	0

12C Table: PLL 2 VCO Frequency Control Register

Byte 17	Pin #	Name	Control	Type	0	1	PWD
			Function				
Bit 7	-	N Div8	N Divider Prog bit 8	RW	The decimal representation of M and N Divier in Byte 17 and 18 will configure the VCO frequency. Default at power up = Byte 0 Rom table. VCO Frequency = $14.318 \times [NDiv(9:0)+8] / [MDiv(5:0)+2]$		X
Bit 6	-	N Div9	N Divider Prog bit 9	RW			X
Bit 5	-	M Div5	M Divider Programming bits	RW			X
Bit 4	-	M Div4		RW			X
Bit 3	-	M Div3		RW			X
Bit 2	-	M Div2		RW			X
Bit 1	-	M Div1		RW			X
Bit 0	-	M Div0		RW			X

12C Table: PLL 2 VCO Frequency Control Register

Byte 18	Pin #	Name	Control	Type	0	1	PWD
			Function				
Bit 7	-	N Div7	N Divider Programming b(8:0)	RW	The decimal representation of M and N Divier in Byte 17 and 18 will configure the VCO frequency. Default at power up = Byte 0 Rom table. VCO Frequency = $14.318 \times [NDiv(9:0)+8] / [MDiv(5:0)+2]$		X
Bit 6	-	N Div6		RW			X
Bit 5	-	N Div5		RW			X
Bit 4	-	N Div4		RW			X
Bit 3	-	N Div3		RW			X
Bit 2	-	N Div2		RW			X
Bit 1	-	N Div1		RW			X
Bit 0	-	N Div0		RW			X

12C Table: PLL 2 Spread Spectrum Control Register

Byte 19	Pin #	Name	Control	Type	0	1	PWD
			Function				
Bit 7	-	SSP7	Spread Spectrum Programming b(7:0)	RW	These Spread Spectrum bits in Byte 19 and 20 will program the spread percentage. It is recommended to use ICS Spread % table for spread programming.		X
Bit 6	-	SSP6		RW			X
Bit 5	-	SSP5		RW			X
Bit 4	-	SSP4		RW			X
Bit 3	-	SSP3		RW			X
Bit 2	-	SSP2		RW			X
Bit 1	-	SSP1		RW			X
Bit 0	-	SSP0		RW			X



I²C Table: PLL2 Spread Spectrum Control Register

Byte 20	Pin #	Name	Control	Type	0	1	PWD
			Function				
Bit 7	-	Reserved	Reserved	R	-	-	0
Bit 6	-	SSP14	Spread Spectrum Programming b(14:8)	RW	These Spread Spectrum bits in Byte 19 and 20 will program the spread percentage. It is recommended to use ICS Spread % table for spread programming.		X
Bit 5	-	SSP13		RW			X
Bit 4	-	SSP12		RW			X
Bit 3	-	SSP11		RW			X
Bit 2	-	SSP10		RW			X
Bit 1	-	SSP9		RW			X
Bit 0	-	SSP8		RW			X

Test Clarification Table

Comments	HW		SW		OUTPUT
	FSLC/TEST_SEL HW PIN	FSLB/TEST_MODE HW PIN	TEST ENTRY BIT W1b7	REF/N or HI-Z W2b3	
		0	X	0	
Power-up w/ TEST_SEL = 1 to enter test mode Cycle power to disable test mode FSLC./TEST_SEL -->3-level latched input If power-up w/ V>2.0V (-0.3V) then use TEST_SEL If power-up w/ V<2.0V (-0.3V) then use FSLC FSLB/TEST_MODE -->low Vth input TEST_MODE is a	1	0	X	0	HI-Z
	1	0	X	1	REF/N
	1	1	X	0	REF/N
	1	1	X	1	REF/N
If TEST_SEL HW pin is 0 during power-up, test mode can be invoked through W1b7. If test mode is invoked by W1b7, only W2b3 is used to select HI-Z or REF/N FSLB/TEST_Mode pin is not used. Cycle power to disable test mode, one shot control	0	X	1	0	HI-Z
	0	X	1	1	REF/N
W1b7: 1= ENTER TEST MODE, Default = 0 (NORMAL OPERATION)					
W2b3: 1= REF/N, Default = 0 (HI-Z)					

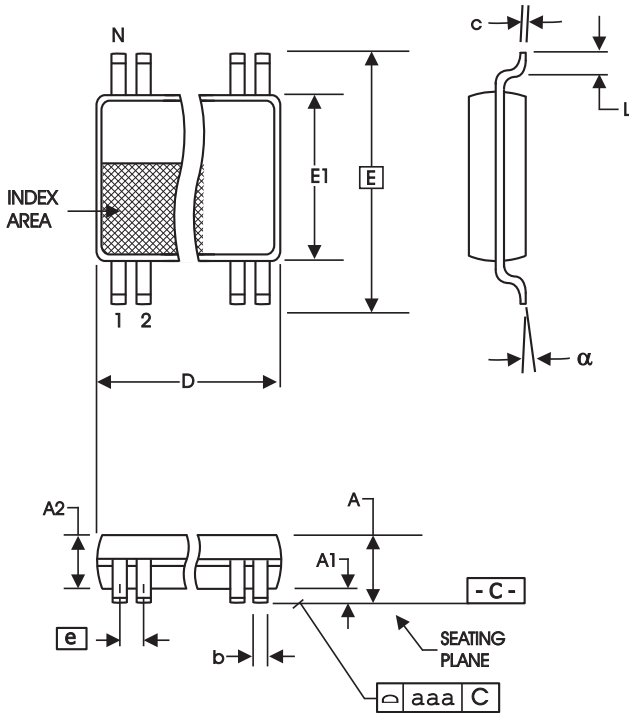

56-Lead 6.10 mm. Body, 0.50 mm. Pitch TSSOP
(240 mil) (20 mil)

SYMBOL	In Millimeters		In Inches	
	COMMON DIMENSIONS	COMMON DIMENSIONS	COMMON DIMENSIONS	COMMON DIMENSIONS
A	--	1.20	--	.047
A1	0.05	0.15	.002	.006
A2	0.80	1.05	.032	.041
b	0.17	0.27	.007	.011
c	0.09	0.20	.0035	.008
D	SEE VARIATIONS		SEE VARIATIONS	
E	8.10 BASIC		0.319 BASIC	
E1	6.00	6.20	.236	.244
e	0.50 BASIC		0.020 BASIC	
L	0.45	0.75	.018	.030
N	SEE VARIATIONS		SEE VARIATIONS	
alpha	0°	8°	0°	8°
aaa	--	0.10	--	.004

VARIATIONS

N	D mm.		D (inch)	
	MIN	MAX	MIN	MAX
56	13.90	14.10	.547	.555

Reference Doc.: JEDEC Publication 95, MO-153

10-0039

Ordering Information

ICS954206BGLFT

Example:

ICS XXXX B G LFT

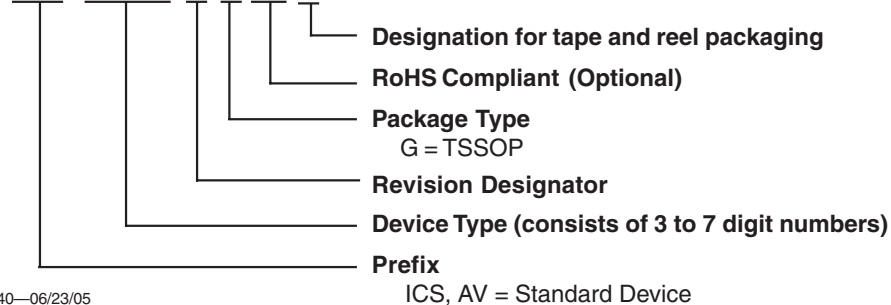

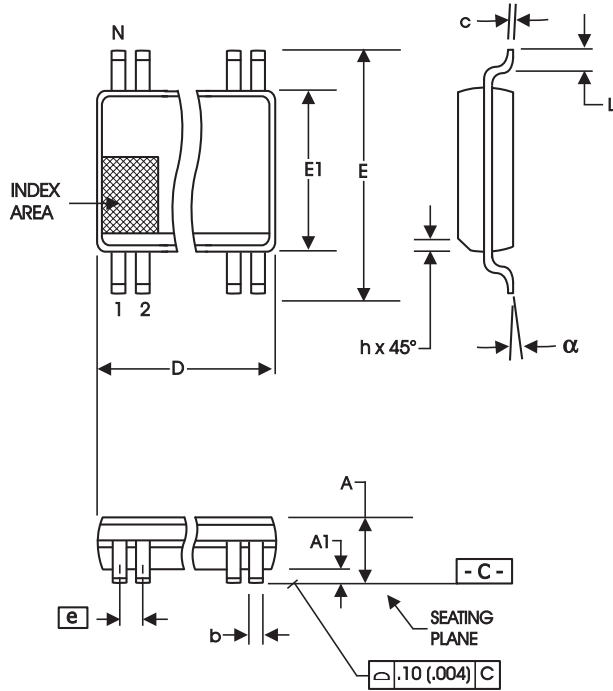

56-Lead, 300 mil Body, 25 mil, SSOP

SYMBOL	In Millimeters COMMON DIMENSIONS		In Inches COMMON DIMENSIONS	
	MIN	MAX	MIN	MAX
A	2.41	2.80	.095	.110
A1	0.20	0.40	.008	.016
b	0.20	0.34	.008	.0135
c	0.13	0.25	.005	.010
D	SEE VARIATIONS		SEE VARIATIONS	
E	10.03	10.68	.395	.420
E1	7.40	7.60	.291	.299
e	0.635 BASIC		0.025 BASIC	
h	0.38	0.64	.015	.025
L	0.50	1.02	.020	.040
N	SEE VARIATIONS		SEE VARIATIONS	
alpha	0°	8°	0°	8°

VARIATIONS

N	D mm.		D (inch)	
	MIN	MAX	MIN	MAX
56	18.31	18.55	.720	.730

Reference Doc.: JEDEC Publication 95, MO-118

10-0034

Ordering Information

ICS954206BFLFT

Example:

ICS XXXX B F LFT

- ICS — Prefix
ICS, AV = Standard Device
- XXXX — Device Type (consists of 3 to 7 digit numbers)
- B — Revision Designator
- F — Package Type
F = SSOP
- LFT — Designation for tape and reel packaging
RoHS Compliant (Optional)



Revision History

Rev.	Issue Date	Description	Page #
N/A	12/9/2004	Added SSOP ordering information	19
0.1	6/22/2005	Updated Ordering Information.	18-19
0.2	6/23/2005	Updated Test Clarification Table	17