

**MSDL (Mobile Shrink Data Link) Transceivers for Mobile Phones**

# Data rate 1350Mbps RGB Interface

**BU7963GUW**

No.10058EAT05

**●Description**

BU7963GUW is a differential serial interface connecting mobile phone LCD modules to the host CPU. Unique technology is utilized for lower power consumption and EMI. MSDL minimizes the number of wires required - an important consideration in hinge phones - resulting in greater reliability and design flexibility.

**●Features**

- 1) MSDL3 high-speed differential interface with a maximum transfer rate of 1350 Mbps.
- 2) Compatible with 24-bit RGB video mode for LCD controller-to-LCD interface.
- 3) Pixel clock frequency range from 4 to 45MHz.
- 4) Depending on the data transfer rate, one, two or three differential data channels can be selected.

**●Applications**

Serial Interface for LCD Display Interface of Mobile Devices Application.

**●Absolute Maximum Ratings:**

Parameter	Symbol	Ratings	Unit	Remarks
Power Supply Voltage	DVDD	-0.3 ~ +2.5	V	-
	MSVDD	-0.3 ~ +2.5	V	-
Input Voltage	VIN	-0.3 ~ MSVDD+0.3	V	I/O terminals of MSVDD line
		-0.3 ~ DVDD+0.3	V	I/O terminals of DVDD line
Output Voltage	VOUT	-0.3 ~ MSVDD+0.3	V	I/O terminals of MSVDD line
		-0.3 ~ DVDD+0.3	V	I/O terminals of DVDD line
Input Current	IIN	-10 ~ +10	mA	-
Output Current	IOUT	-70 ~ +70	mA	-
Preservation Temperature	Tstg	-55 ~ +125	°C	-

**●Operating Conditions:**

Parameter	Symbol	Ratings			Unit	Conditions
		Min	Typ	Max		
Supply Voltage for DVDD	V <sub>DVDD</sub>	1.65	1.80	1.95	V	V <sub>DVDD</sub> = V <sub>MSVDD</sub>
Supply Voltage for MSVDD	V <sub>MSVDD</sub>	1.65	1.80	1.95	V	
Data Transmission Rate	DR	120	-	450	Mbps/ch	-
Operating Temperature Range	T <sub>opr</sub>	-30	25	85	°C	-

● Package View

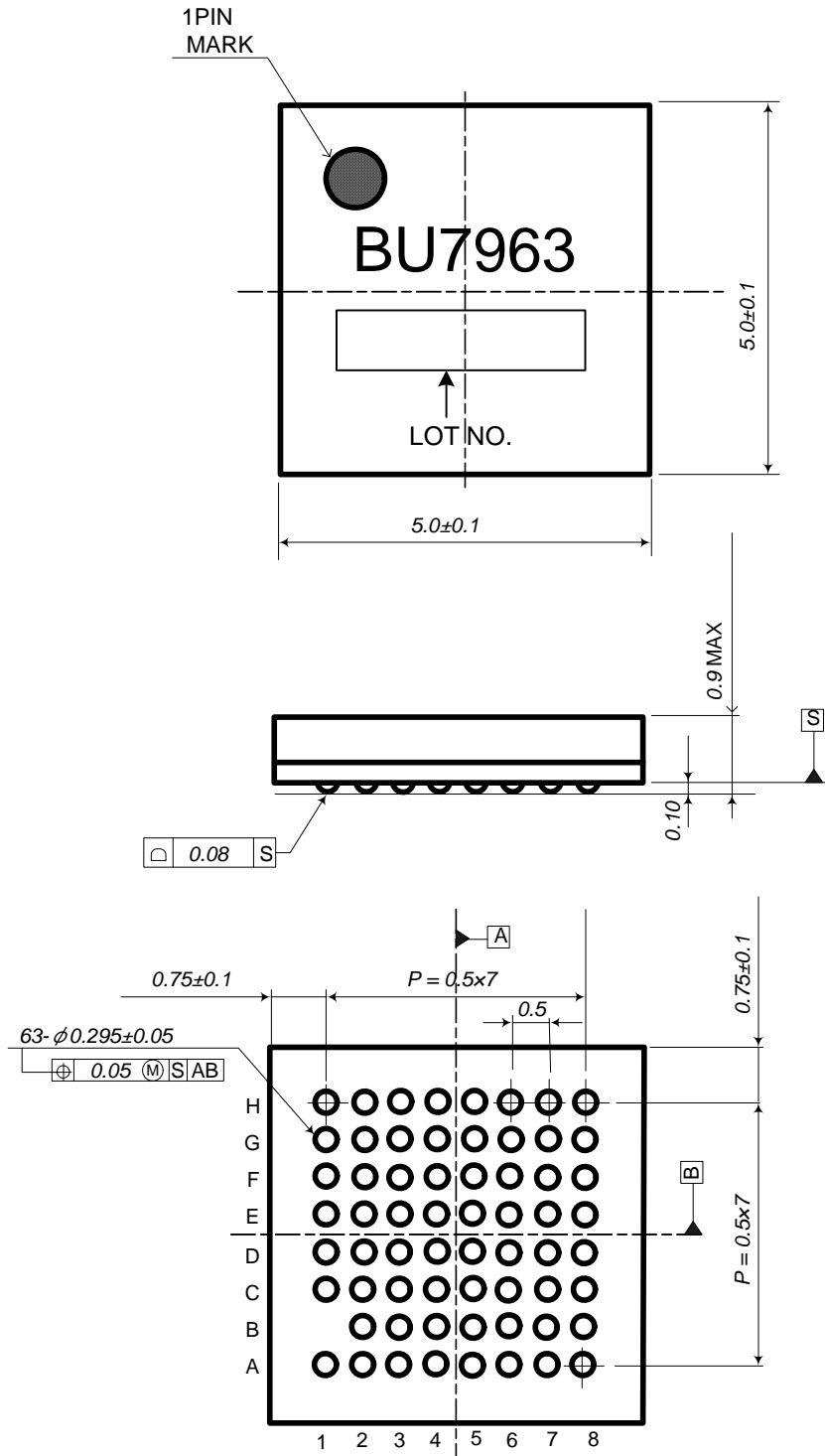

(UNIT:mm)

Fig.1. Package View (VBGA063W050)

●Block Diagram

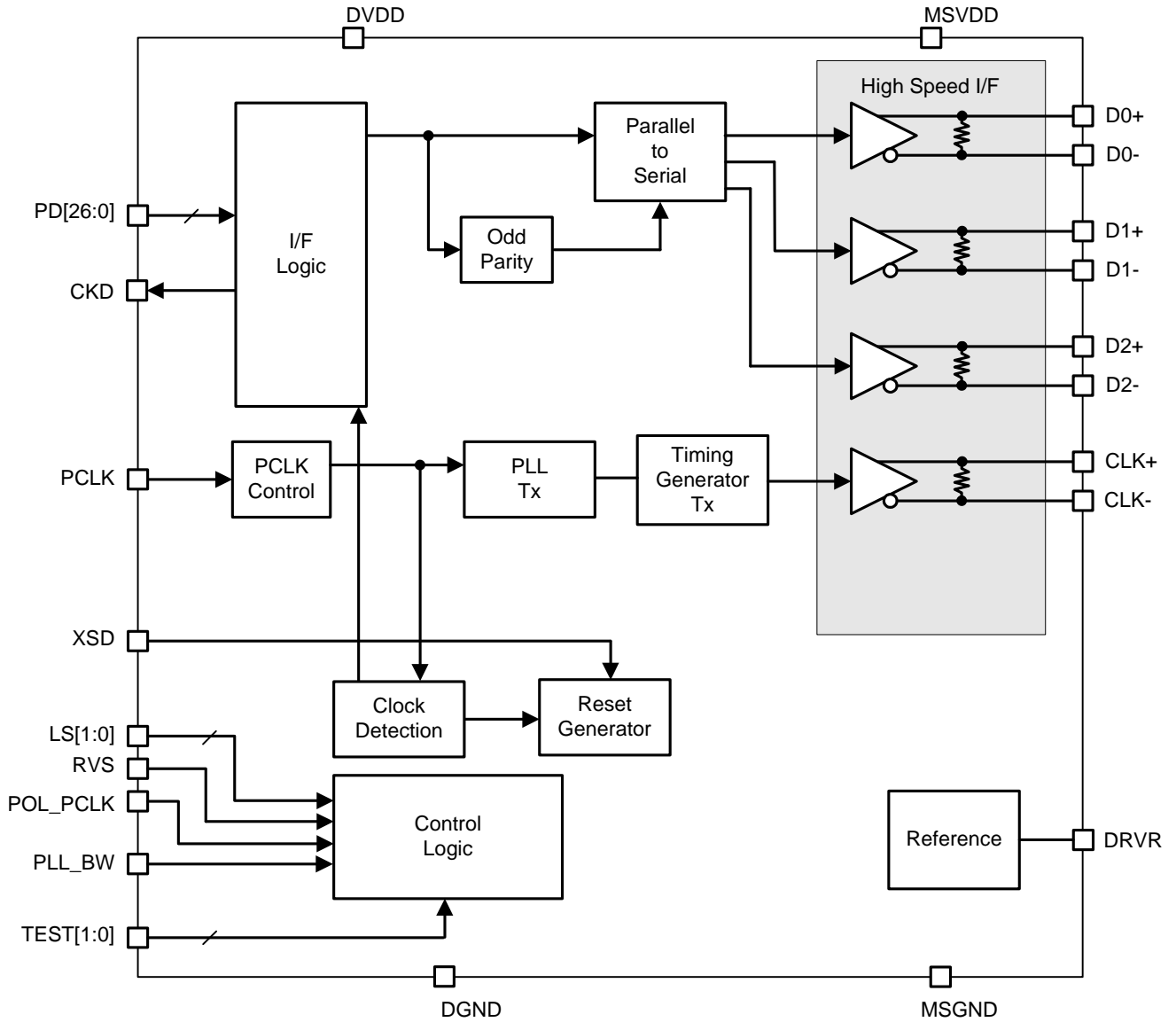

Fig.2. Block Diagram

## ● Pin Layout

	1	2	3	4	5	6	7	8
A	TEST0	PD19	PD17	PD16	PD14	PD13	PD10	CKD
B	X	PCLK	PD18	PD15	PD12	PD11	PD9	PD8
C	PD22	PD20	PLL_BW	DVDD	N.C.	RVS	PD7	PD6
D	PD23	PD21	N.C.	DGND	DGND	DVDD	PD4	PD5
E	PD25	PD24	DVDD	DGND	MSGND	N.C.	PD1	PD3
F	PD26	LS0	MSVDD	MSGND	MSVDD	N.C.	XSD	PD2
G	LS1	POL_ PCLK	D2+ (D0+)	D1+ (CLK+)	CLK+ (D1+)	D0+ (D2+)	N.C.	PD0
H	N.C.	N.C.	D2- (D0-)	D1- (CLK-)	CLK- (D1-)	D0- (D2-)	DRVR	TEST1

Fig.3. Pin Layout (Top View)

## ● Pin Functions

Table 1. Power Supply and Ground

Power Supply / Ground : 10-pin		
Name	Width	Functions
DVDD	3	CMOS I/O and logic core power supply.
MSVDD	2	Analog core power supply.
DGND	3	CMOS I/O and logic core ground.
MSGND	2	Analog core ground.

Table 2. MSDL3

High-Speed Serial Interface 8-pin						
Name	Width	Level	I/O	Functions	Shutdown	Equivalent Schematic
CLK+	1	Analog	O	CLK+ pin When RVS = 'L' : CLK+ When RVS = 'H' : D1+	Hi-Z	D
CLK-	1	Analog	O	CLK- pin When RVS = 'L' : CLK- When RVS = 'H' : D1-	Hi-Z	D
D0+	1	Analog	O	D0+ pin When RVS = 'L' : D0+ When RVS = 'H' : D2+	Hi-Z	D
D0-	1	Analog	O	D0- pin When RVS = 'L' : D0- When RVS = 'H' : D2-	Hi-Z	D
D1+	1	Analog	O	D1+ pin When RVS = 'L' : D1+ When RVS = 'H' : CLK+	Hi-Z	D
D1-	1	Analog	O	D1- pin When RVS = 'L' : D1- When RVS = 'H' : CLK-	Hi-Z	D
D2+	1	Analog	O	D2+ pin When RVS = 'L' : D2+ When RVS = 'H' : D0+	Hi-Z	D
D2-	1	Analog	O	D2- pin When RVS = 'L' : D2- When RVS = 'H' : D0-	Hi-Z	D

Table 3. Analog

Analog 1-pin						
Name	Width	Level	I/O	Functions	Shutdown	Equivalent Schematic
DRVR	1	Analog	-	10kΩ±5% register should be connected between DRVR and MSGND.	-	D

Table 4. Parallel Data Interface

Parallel Data Interface		29-pin					
Name	Width	Level	I/O	Functions	Shutdown	Equivalent Schematic	
PCLK	1	CMOS	I	PCLK interface.	Input	A	
PD[26:0]	27	CMOS	I	Parallel data interface.	Input	A	
CKD	1	CMOS	O	Output of PCLK detection result. 'L': clock stop. 'H': clock detect.	'L'	C	

Table 5. Control

Control		8-pin					
Name	Width	Level	I/O	Functions	Shutdown	Equivalent Schematic	
XSD	1	CMOS	I	Shutdown pin. 'L': shutdown. 'H': normal operation.	Input	A	
LS0	1	CMOS	I	Selection of the number of data channel and the data format. * Refer to "Selection of the number of MSDL3 channels". * Set the same number of data channel between the TX device and the RX device.	Input	A	
LS1	1						
RVS	1	CMOS	I	Selection of MSDL3 pins assignment. 'L': Default matrix. 'H': Flipped matrix.	Input	A	
PLL_BW	1	CMOS	I	Selection of PLL bandwidth.	Input	A	
POL_PCLK	1	CMOS	I	Selection of input clock polarity. 'L': sample parallel data at falling. 'H': sample parallel data at rising.	Input	A	
TEST0	1	Pull down	I	Test mode pin. 'L': normal mode. 'H': test mode. Must be 'L.'	Input	B	
TEST1	1					B	

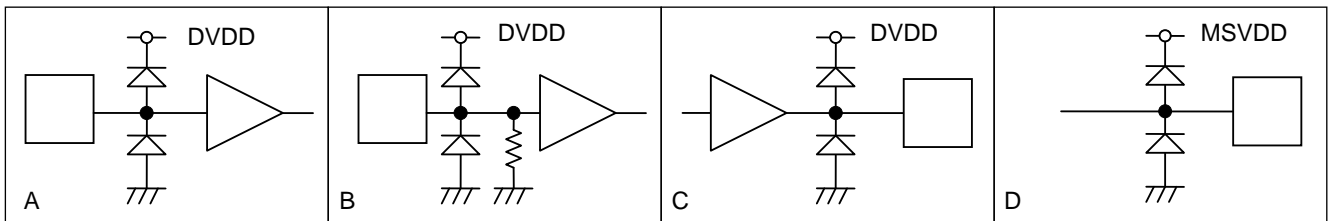

Fig.4. Equivalent Schematics

●Operation Control

MSDL3 Channel Count Selection

Pin LS is used to control the high-speed data channel count and data format. The LS pin settings (i.e., high-speed data channel count, data format) should be the same between the transmitting and receiving devices (the BU7963GUW and BU7964GUW, respectively). Table 6 shows the PCLK input frequency ranges and transmission data rate ranges for the LS pin settings.

Table 6. The Range of The Transmission Data rate

LS1	LS0	The Number of Data Channel	The Range of PCLK Input Frequency [MHz]	The Range of The Data Transmission Rate [Mbits/sec]
'L'	'L'	1-channel	4.0-15.0	120-450
'L'	'H'	2-channel	8.0-30.0	240-900
'H'	'L'	3-channel	12.0-45.0	360-1350
'H'	'H'	Inhibit setting.		

MSDL3 Pin Assignment

RVS determines the assignment of MSDL3 pins, CLK+ / CLK-, D0+ / D0-, D1+ / D1- and D2+ / D2-. Only the MSDL3 high-speed signaling pins are affected by RVS, while pin assignment of other functions does not change. User can select the assignment from 'straight' (default) and 'flipped' assignment in order to minimize channel-to-channel skew in PWB design. Table 7 shows the MSDL3 pin assignment, and Fig.5 shows the 'straight' and 'flipped'

Table 7. MSDL3 Pin Assignment

RVS	MSDL3 Pin Assignment
'L'	'Straight' (default matrix)
'H'	'Flipped'

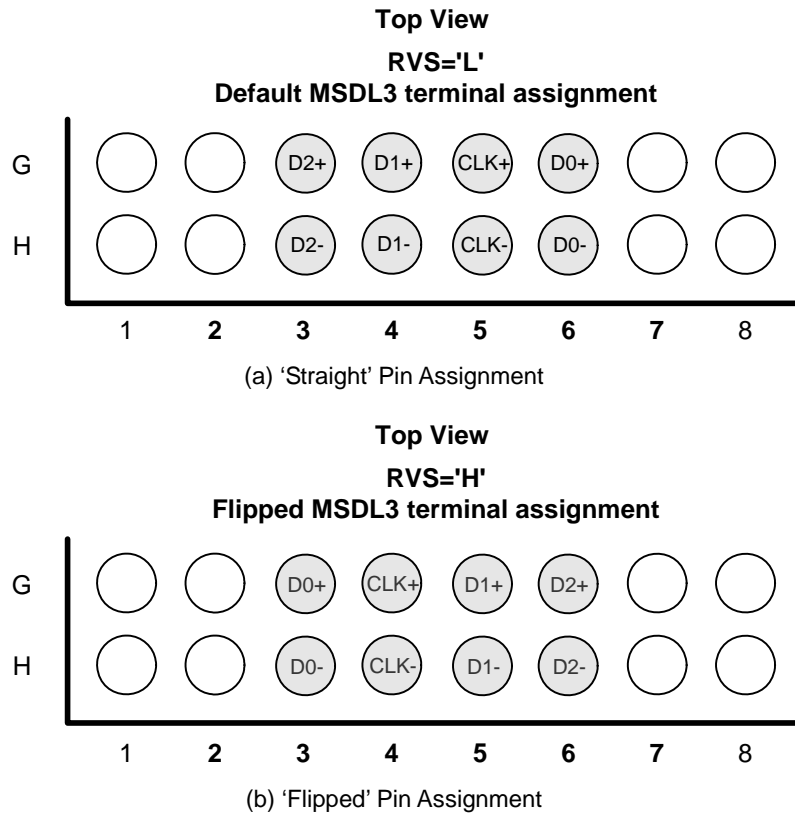

Fig.5. MSDL3 Pin Assignment

## PCLK Polarity Selection

BU7963GUW controls PCLK input polarity by POL\_PCLK setting. Table 8 shows PCLK input polarity.

Table 8. PCLK Polarity Selection

POL_PCLK	Parallel Data Capturing Polarity
'L'	Capture parallel data at falling edge.
'H' (default)	Capture parallel data at rising edge.

## PLL Bandwidth Selection

BU7963GUW controls the range of the CLK+ / CLK- input frequency (= PCLK output frequency) by the setting of the data format (LS1, and LS0) of the high-speed data channel and the bandwidth setting of PLL\_BW.

Table 9. PLL\_BW Setting

LS1	LS0	PLL_BW	CLK+ / CLK- Frequency Range [MHz] (PCLK Input Frequency)	
			Min	Max
'L'	'L'	'L'	4	8
'L'	'L'	'H'	7	15
'L'	'H'	'L'	8	16
'L'	'H'	'H'	14	30
'H'	'L'	'L'	12	24
'H'	'L'	'H'	21	45



● Power Modes

BU7963GUW has three power modes.

1) Shutdown Mode

BU7963GUW goes to Shutdown Mode when XSD = 'L'. All logic circuits are initialized in the Shutdown Mode. All high-speed signaling channels are disabled, and the outputs keep Hi-Z status.

2) Standby Mode

BU7963GUW goes to Standby Mode when XSD = 'H' and PCLK is not provided. All high-speed signaling channel outputs keep Hi-Z status. BU7963GUW is monitoring whether PCLK input is running or not and the link switches to Active Mode when PCLK running is detected.

3) Active Mode

BU7963GUW goes to Active Mode when XSD = 'H' and PCLK is running. All high-speed signaling channels are enabled.

Table 10. Power Modes

Power Mode	Input		Operation	
	XSD	PCLK	Functions	MSDL3 Terminals
Shutdown	'L'	Static ('L' or 'H')	Initialized	Disabled (Hi-Z)
Standby	'H'	Static ('L' or 'H')	PCLK detection	Disabled (Hi-Z)
Active	'H'	Clock input is active	PCLK detection Normal operation (P2S conv)	Enabled

4) Power Modes Transition

Fig.6 shows the transition of power modes.

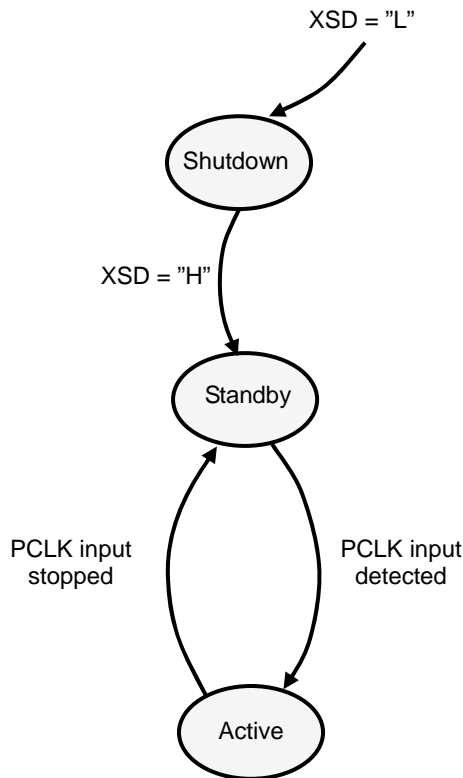

Fig.6. Power Modes Transition

●High-Speed Data Channel Protocols

Fig.7, Fig.8 and Fig.9 show high-speed data channel protocols.

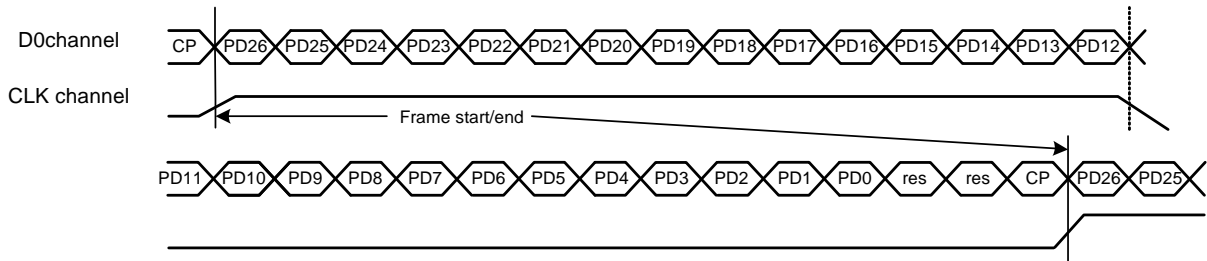

Fig.7. MSDL3 Protocol for 1-channel Data (27-bit)

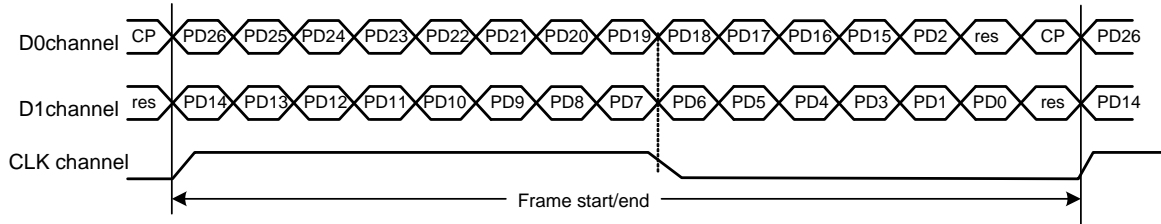

Fig.8. MSDL3 Protocol for 2-channel Data (27-bit)

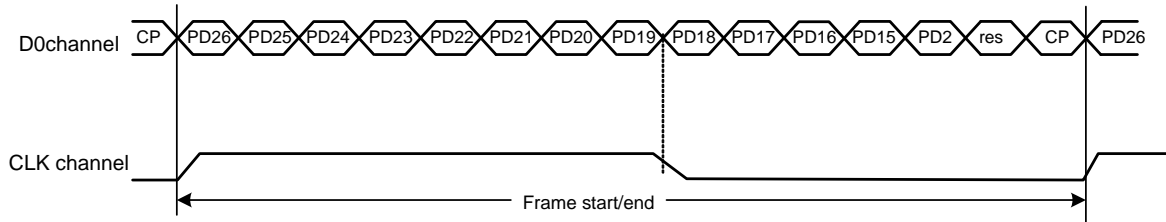

Fig.9. MSDL3 Protocol for 1-channel Data (13-bit)

“res” is reserved bit for the future use, the default state of those is ‘0.’

CP is the parity bit of data payload. BU7961GUW adds an odd parity on CP of the high-speed channel data.

- When the number of ‘H’ bits in parallel data is even, CP bit is ‘H.’
- When the number of ‘H’ bits in parallel data is odd, CP bits is ‘L.’

## ●Electrical Characteristics

### 1) DC Characteristics

Table 11. Digital Input / Output DC Characteristics

Ta=25°C, DVDD=MSVDD=1.80V and DGND=MSGND=0.00V, unless otherwise noted.

Parameter	Symbol	Limits			Unit	Conditions
		Min	Typ	Max		
'L' Input Voltage 1	VIL1	DGND	-	0.3 x DVDD	V	PCLK, PD[26:0], LS[1:0], RVS, POL_PCLK, XSD, PLL_BW, TEST[1:0] pin
'H' Input Voltage 1	VIH1	0.7 x DVDD	-	DVDD	V	PCLK, PD[26:0], LS[1:0], RVS, POL_PCLK, PLL_BW, TEST[1:0] pin
'L' Input Current 1	IIL1	-5	-	+5	μA	VIN = DGND
'H' Input Current 1	IIH1	-5	-	+5	μA	VIN = DVDD
'L' Input Current 2	IIL2	-5	-	+5	μA	VIN = MSGND
'H' Input Current 2	IIH2	-5	-	+5	μA	VIN = MSVDD
'L' Output Voltage 1	VOL1	DGND	-	0.3 x DVDD	V	IO = 1mA,CKD pin
'H' Output Voltage 1	VOH1	0.7 x DVDD	-	DVDD	V	IO = -1mA,CKD pin

Table 12 Current Consumption

Ta=25°C, DVDD=MSVDD=1.80V and DGND=MSGND=0.00V, unless otherwise noted.

Parameter	Symbol	Limits			Unit	Conditions
		Min	Typ	Max		
Shutdown Current	I <sub>op_sht_rx</sub>	-	0.2	10	μA	XSD = 'L', IDVDD + IMSVDD
Standby Current	I <sub>op_stb_rx</sub>	-	0.2	10	μA	XSD = 'H', IDVDD + IMSVDD
Active Current 1-channel / 27-bit Format	I <sub>op_act_rx1</sub>	-	14.0	18.5	mA	LS[1:0] = 'LL', PLL_BW[1:0] = 'H' DVDD = MSVDD PCLK=15MHz, XSD='H' CL=10pF Total operating current (IDVDD + IMSVDD ) with PD[26:0] inputs to ggling 0x2AAAAAA and 0x5555555
Active Current 2-channel / 27-bit Format	I <sub>op_act_rx2</sub>	-	19.7	25.7	mA	LS[1:0] = 'LH', PLL_BW[1:0] = 'H' DVDD = MSVDD PCLK=30MHz, XSD='H' CL=10pF Total operating current (IDVDD + IMSVDD) with PD[26:0] inputs to ggling 0x2AAAAAA and 0x5555555
Active Current 3-channel / 27-bit Format	I <sub>op_act_rx3</sub>	-	25.4	32.9	mA	LS[1:0] = 'HL', PLL_BW[1:0] = 'H' DVDD = MSVDD PCLK=45MHz, XSD='H' CL=10pF Total operating current (IDVDD + IMSVDD) with PD[26:0] inputs to ggling 0x2AAAAAA and 0x5555555

2) AC Characteristics  
Parallel Data Input Timing

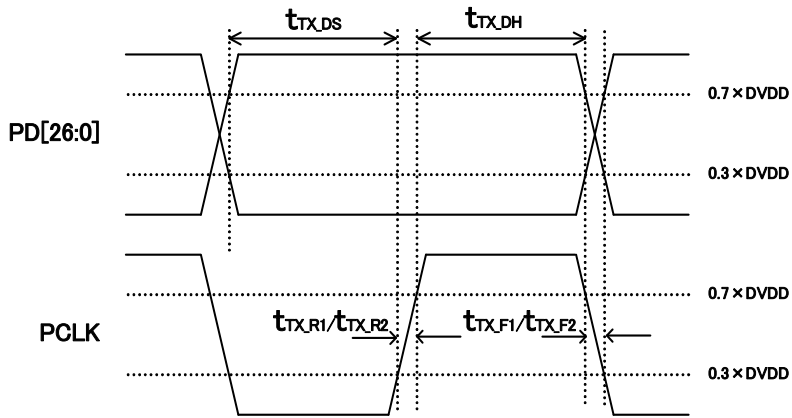

Fig.10 Parallel Data Input AC Timing

Table 13. Parallel Data Input AC Timing

Ta=25°C, DVDD=MSVDD=1.80V and DGND=MSGND=0.00V, unless otherwise noted.

Parameter	Symbol	Limits			Unit	Conditions
		Min	Typ	Max		
PCLK Input Frequency	f <sub>TX_PCLK1</sub>	4	-	15	MHz	LS0=L, LS1=L
	f <sub>TX_PCLK2</sub>	8	-	30	MHz	LS0=H, LS1=L
	f <sub>TX_PCLK3</sub>	12	-	45	MHz	LS0=L, LS1=H
PCLK Input Duty Cycle	t <sub>TX_DUTY</sub>	33	-	67	%	
Input Data Setup Time	t <sub>TX_DS</sub>	5.0	-	-	ns	POL_PCLK=H
Input Data Hold Time	t <sub>TX_DH</sub>	5.0	-	-	ns	POL_PCLK=H
Input Signal Rise Time 1	t <sub>TX_R1</sub>	-	-	10	ns	PCLK Frequency ≤ 30MHz
Input Signal Rise Time 2	t <sub>TX_R2</sub>	-	-	5	ns	PCLK Frequency > 30MHz
Input Signal Fall Time 1	t <sub>TX_F1</sub>	-	-	10	ns	PCLK Frequency ≤ 30MHz
Input Signal Fall Time 2	t <sub>TX_F2</sub>	-	-	5	ns	PCLK Frequency > 30MHz

3) Serial Data Input Timing

Fig.11 and Table 14 shows Serial Data Input Timing of BU7963GUW.

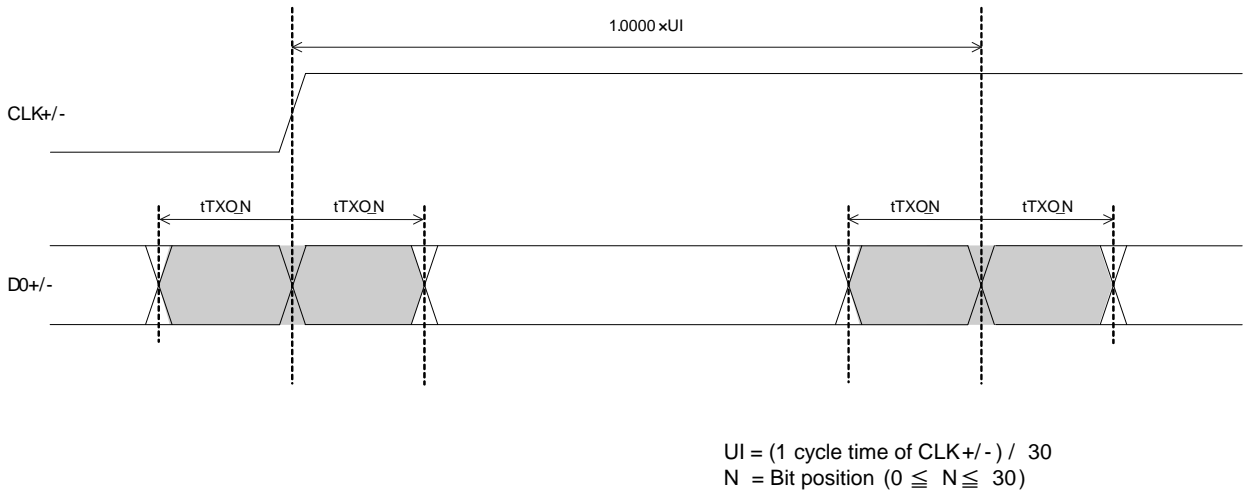

Fig.11. Serial Data input AC Timing

Table 14. Serial Data input AC Timing

Ta=25°C, DVDD=MSVDD=1.80V and DGND=MSGND=0.00V, unless otherwise noted.

Parameter	Symbol	Limits			Unit	Conditions
		Min	Typ	Max		
Output location CLKL+/- of N bit	t <sub>TXO_N</sub>	-0.1845×UI + UI×N	UI×N	0.1845×UI + UI×N	sec	

4) Power-On / Off Sequence

Power-On Sequence

Fig.12 shows power-on sequence of BU7963GUW.

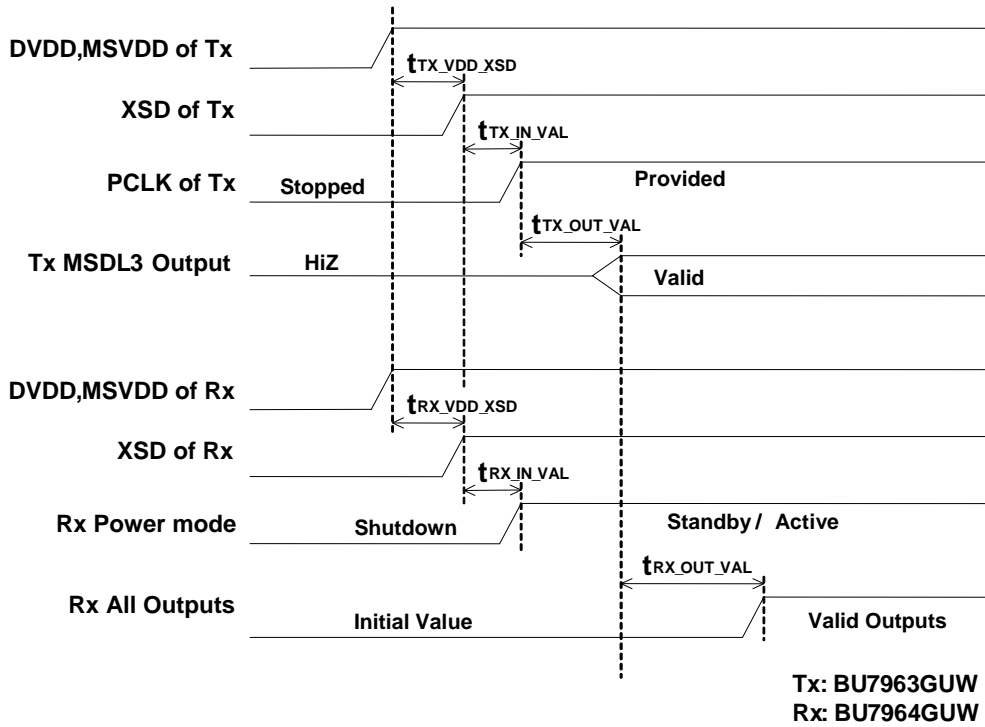

Fig.12. Power-On / Off Sequence

Table 15. Power-On Sequence Timing

Ta=25°C, DVDD=MS VDD=1.80V, and DGND=MSGND=0.00V, unless otherwise noted.

Parameter	Symbol	Limits			Unit	Conditions
		Min	Typ	Max		
Core power supply startup time	$t_{TX\_VDD\_IOV}$	0.0	-	2	ms	
Reset Valid After Power Supplied	$t_{TX\_VDD\_XSD}$	10	-	-	$\mu$ s	
PCLK clock input startup time	$t_{TX\_IN\_VAL}$	10	-	-	$\mu$ s	
MSDL3 output delay time	$t_{TX\_OUT\_VAL}$	-	-	2	ms	

Power-Off Sequence

Fig.13 shows the power-off sequence of BU7963GUW.

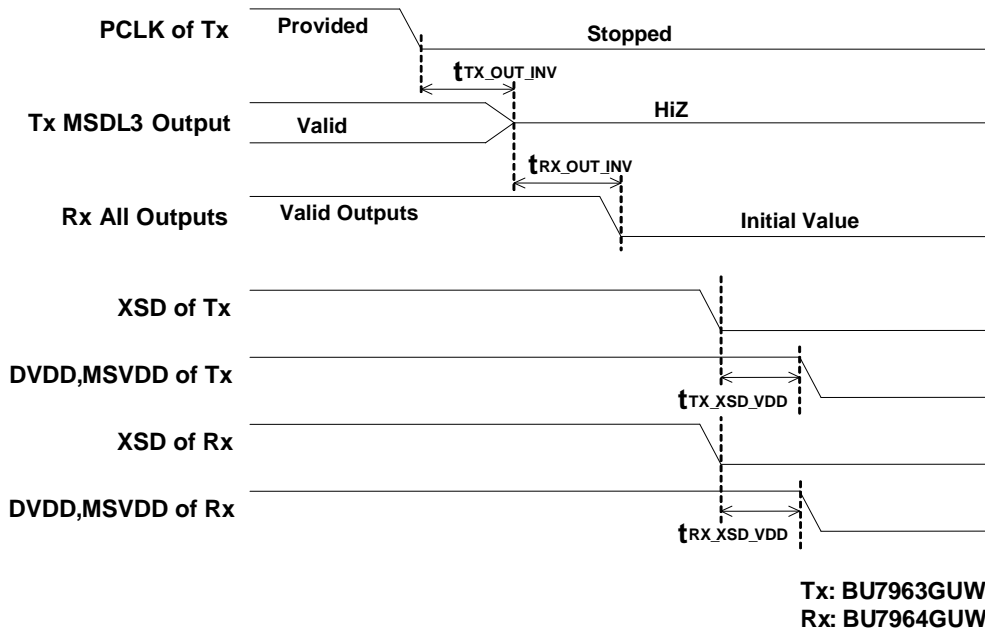

Fig.13. Power-Off Sequence

Table 16. Power-Off Sequence Timing

Ta=25°C, DVDD=MSVDD=1.80V, and DGND=MSGND=0.00V, unless otherwise noted.

Parameter	Symbol	Limits			Unit	Conditions
		Min	Typ	Max		
MSDL3 output delay time	$t_{TX\_OUT\_INV}$	-	-	100	$\mu$ s	
XSD hold time	$t_{TX\_XSD\_VDD}$	10	-	-	$\mu$ s	
Core power off time	$t_{TX\_VDD\_IOV}$	0.0	-	2	ms	

Frequency Change Sequence

Fig.14 shows the frequency change sequence of BU7963GUW.

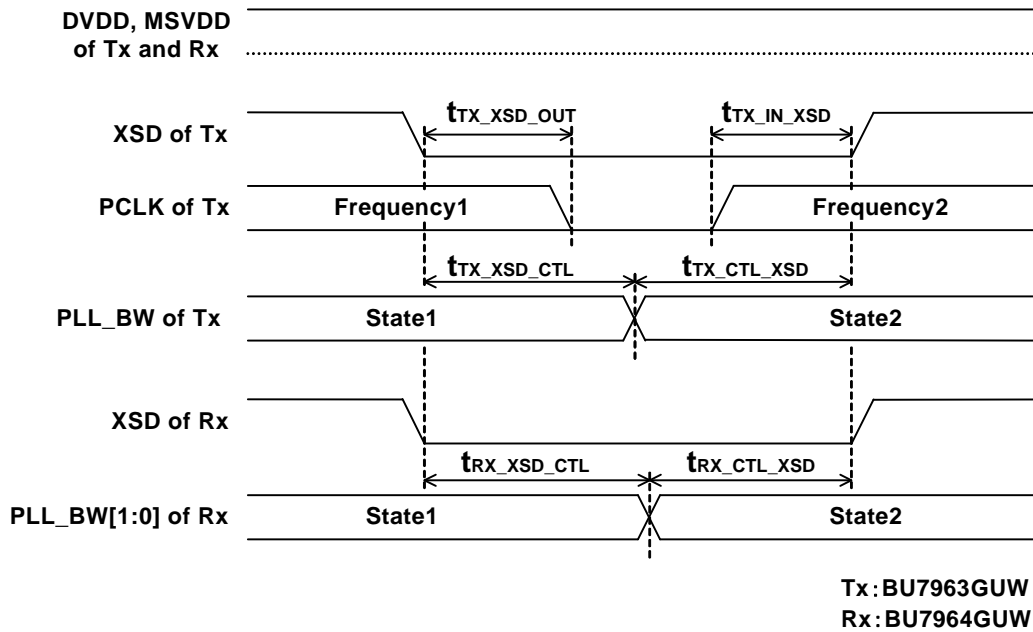

Fig.14. Frequency Change Sequence

Table 17. Frequency Change Sequence

Ta=25°C, DVDD=MSVDD=1.80V, and DGND=MSGND=0.00V, unless otherwise noted.

Parameter	Symbol	Limits			Unit	Conditions
		Min	Typ	Max		
PCLK Clock Input Suspend Time	tTX_XSD_OUT	1.0	-	-	μs	
PCLK Clock Input Restart Time	tTX_IN_XSD	1.0	-	-	μs	
Control Signal Hold Time	tTX_XSD_CTL	2.0	-	-	μs	
Control Signal Setup Time	tTX_CTL_XSD	2.0	-	-	μs	



●High-speed Channel Characteristic

Table 18. High-speed channel characteristic

Ta=25°C, DVDD=MSVDD=1.80V and DGND=MSGND=0.00V, unless otherwise noted.

Parameter	Symbol	Limits			Unit	Conditions
		Min	Typ	Max		
Differential Voltage Range	$V_{diff\_tx}$	100	150	200	mVpp	
Common Mode Voltage Range	$V_{cm\_tx}$	0.8	0.9	1.0	V	
Vdiff_tx Rise Time	$t_{r\_tx}$	200	-	500	ps	
Vdiff_tx Fall Time	$t_{f\_tx}$	200	-	500	ps	
Operating Frequency	$f_{opr\_tx}$	-	-	225	MHz	
TX Hi-Z State Leak Current	$I_{LEAK\_TX}$	-3	-	3	$\mu A$	Shutdown mode or standby mode

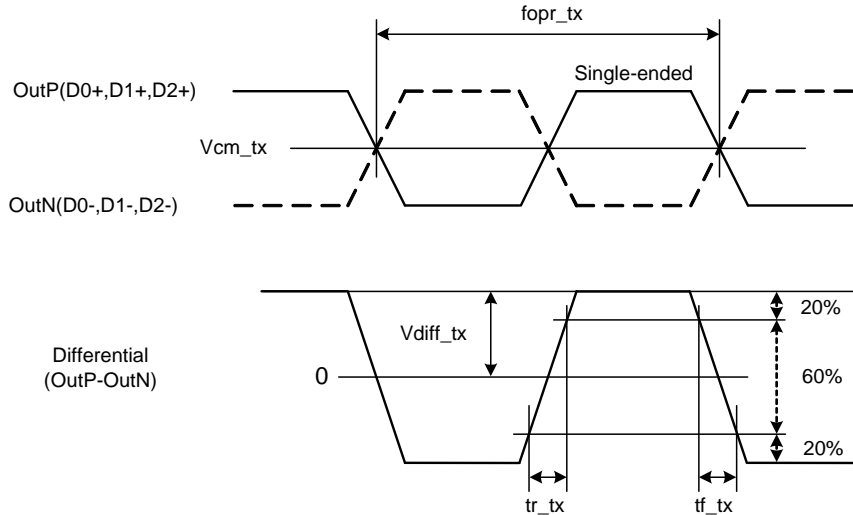

Fig.15. High-Speed Channel Electrical Characteristics

Fig.16 shows high-speed channel equivalent schematic.

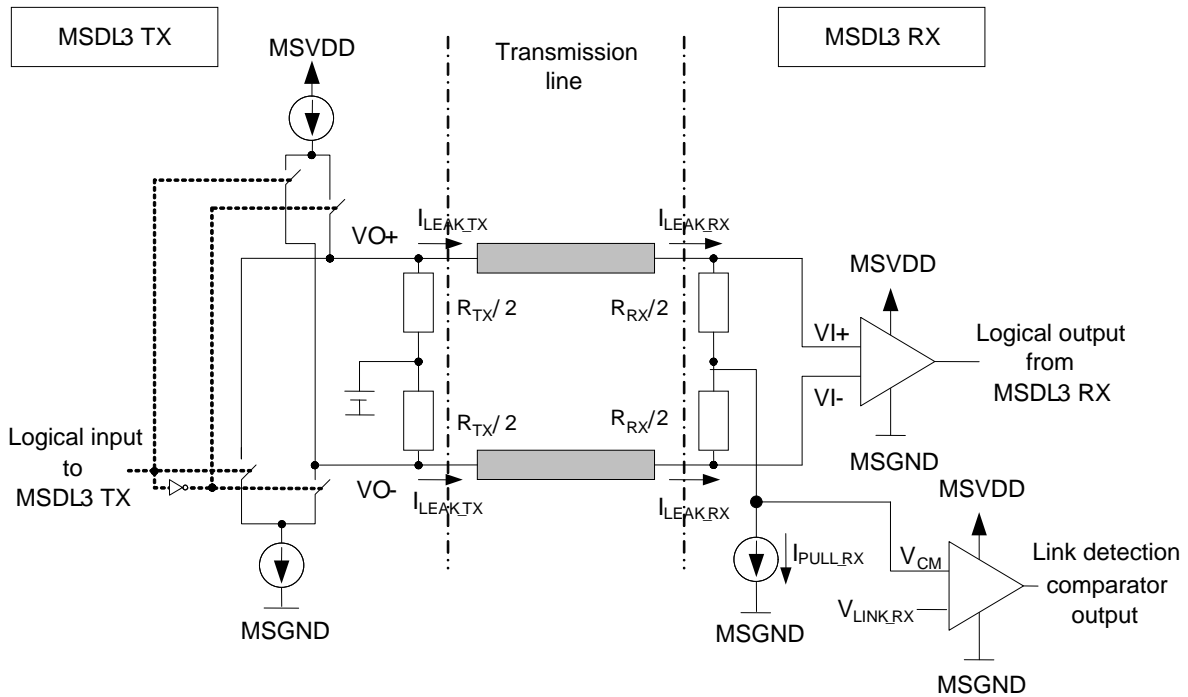

Fig.16. high-speed channel equivalent schematic.

●Application Circuit Example

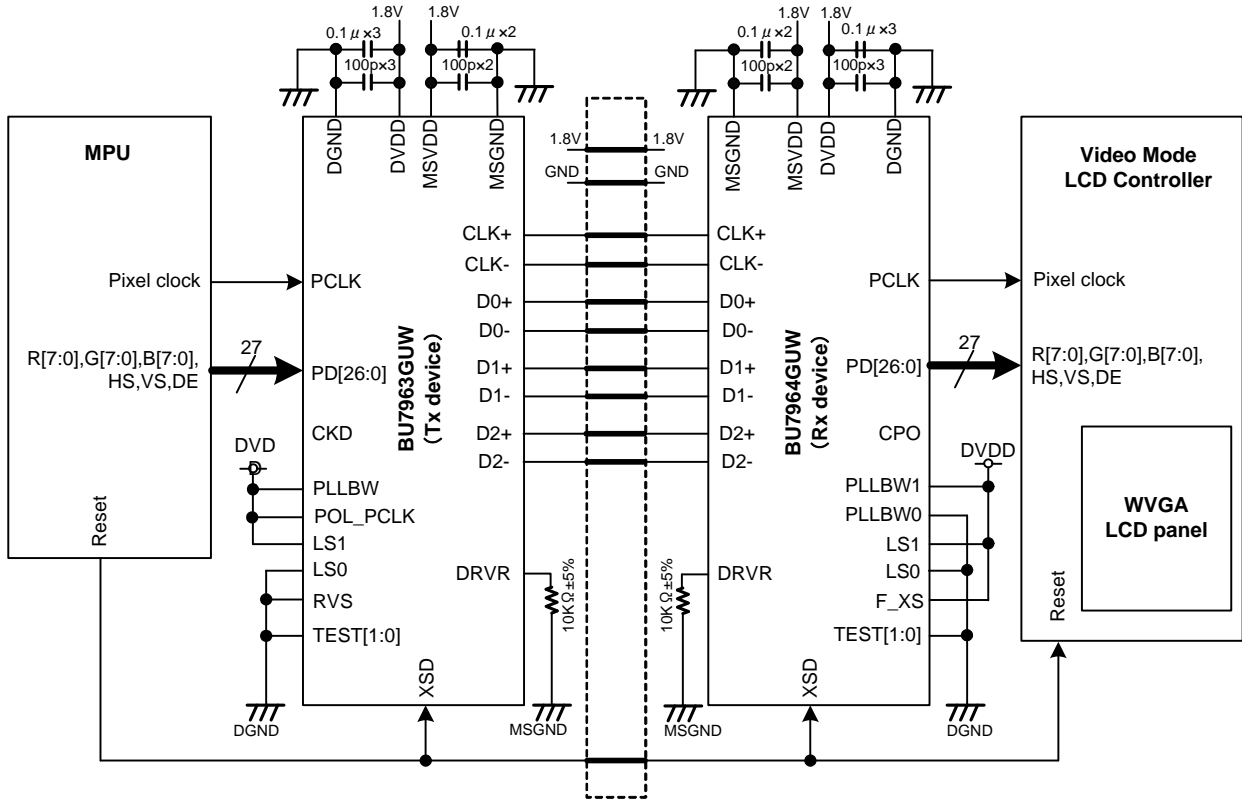

Fig.17. Application circuit

●PCB Layout for MSDL3

The following points should be considered about the wiring for PCB of MSDL3.

- Wire for the PCB wiring pattern of high-speed channel (CLK, D0+/-, D1+/-, D2+/-) as short as possible.
- The PCB wiring for high-speed channel must not use the through-hole.
- Do not bend the wiring for high-speed channel squarely.
- Make the wiring length of each high-speed channel the same length (within 0.5mm).

●Ordering Part Number

B	U
---	---

Part No.

7	9	6	3
---	---	---	---

Part No.

G	U	W
---	---	---

Package  
GUW: VBGA063W050

-	E	2
---	---	---

Packaging and forming specification  
E2: Embossed tape and reel

VBGA063W050

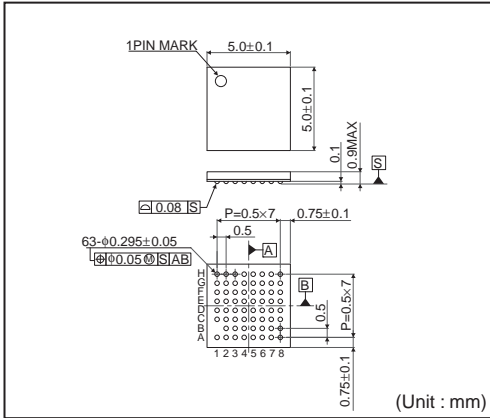

<Tape and Reel information>

Tape	Embossed carrier tape (with dry pack)
Quantity	2500pcs
Direction of feed	E2 ( The direction is the 1pin of product is at the upper left when you hold reel on the left hand and you pull out the tape on the right hand )

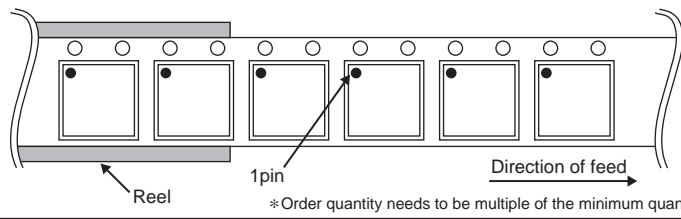

# Notice

## Precaution on using ROHM Products

- Our Products are designed and manufactured for application in ordinary electronic equipments (such as AV equipment, OA equipment, telecommunication equipment, home electronic appliances, amusement equipment, etc.). If you intend to use our Products in devices requiring extremely high reliability (such as medical equipment <sup>(Note 1)</sup>, transport equipment, traffic equipment, aircraft/spacecraft, nuclear power controllers, fuel controllers, car equipment including car accessories, safety devices, etc.) and whose malfunction or failure may cause loss of human life, bodily injury or serious damage to property ("Specific Applications"), please consult with the ROHM sales representative in advance. Unless otherwise agreed in writing by ROHM in advance, ROHM shall not be in any way responsible or liable for any damages, expenses or losses incurred by you or third parties arising from the use of any ROHM's Products for Specific Applications.

(Note1) Medical Equipment Classification of the Specific Applications

JAPAN	USA	EU	CHINA
CLASS III	CLASS III	CLASS II b	CLASS III
CLASS IV		CLASS III	

- ROHM designs and manufactures its Products subject to strict quality control system. However, semiconductor products can fail or malfunction at a certain rate. Please be sure to implement, at your own responsibilities, adequate safety measures including but not limited to fail-safe design against the physical injury, damage to any property, which a failure or malfunction of our Products may cause. The following are examples of safety measures:
  - Installation of protection circuits or other protective devices to improve system safety
  - Installation of redundant circuits to reduce the impact of single or multiple circuit failure
- Our Products are designed and manufactured for use under standard conditions and not under any special or extraordinary environments or conditions, as exemplified below. Accordingly, ROHM shall not be in any way responsible or liable for any damages, expenses or losses arising from the use of any ROHM's Products under any special or extraordinary environments or conditions. If you intend to use our Products under any special or extraordinary environments or conditions (as exemplified below), your independent verification and confirmation of product performance, reliability, etc. prior to use, must be necessary:
  - Use of our Products in any types of liquid, including water, oils, chemicals, and organic solvents
  - Use of our Products outdoors or in places where the Products are exposed to direct sunlight or dust
  - Use of our Products in places where the Products are exposed to sea wind or corrosive gases, including Cl<sub>2</sub>, H<sub>2</sub>S, NH<sub>3</sub>, SO<sub>2</sub>, and NO<sub>2</sub>
  - Use of our Products in places where the Products are exposed to static electricity or electromagnetic waves
  - Use of our Products in proximity to heat-producing components, plastic cords, or other flammable items
  - Sealing or coating our Products with resin or other coating materials
  - Use of our Products without cleaning residue of flux (even if you use no-clean type fluxes, cleaning residue of flux is recommended); or Washing our Products by using water or water-soluble cleaning agents for cleaning residue after soldering
  - Use of the Products in places subject to dew condensation
- The Products are not subject to radiation-proof design.
- Please verify and confirm characteristics of the final or mounted products in using the Products.
- In particular, if a transient load (a large amount of load applied in a short period of time, such as pulse. is applied, confirmation of performance characteristics after on-board mounting is strongly recommended. Avoid applying power exceeding normal rated power; exceeding the power rating under steady-state loading condition may negatively affect product performance and reliability.
- De-rate Power Dissipation (Pd) depending on Ambient temperature (Ta). When used in sealed area, confirm the actual ambient temperature.
- Confirm that operation temperature is within the specified range described in the product specification.
- ROHM shall not be in any way responsible or liable for failure induced under deviant condition from what is defined in this document.

## Precaution for Mounting / Circuit board design

- When a highly active halogenous (chlorine, bromine, etc.) flux is used, the residue of flux may negatively affect product performance and reliability.
- In principle, the reflow soldering method must be used; if flow soldering method is preferred, please consult with the ROHM representative in advance.

For details, please refer to ROHM Mounting specification

**Precautions Regarding Application Examples and External Circuits**

1. If change is made to the constant of an external circuit, please allow a sufficient margin considering variations of the characteristics of the Products and external components, including transient characteristics, as well as static characteristics.
2. You agree that application notes, reference designs, and associated data and information contained in this document are presented only as guidance for Products use. Therefore, in case you use such information, you are solely responsible for it and you must exercise your own independent verification and judgment in the use of such information contained in this document. ROHM shall not be in any way responsible or liable for any damages, expenses or losses incurred by you or third parties arising from the use of such information.

**Precaution for Electrostatic**

This Product is electrostatic sensitive product, which may be damaged due to electrostatic discharge. Please take proper caution in your manufacturing process and storage so that voltage exceeding the Products maximum rating will not be applied to Products. Please take special care under dry condition (e.g. Grounding of human body / equipment / solder iron, isolation from charged objects, setting of Ionizer, friction prevention and temperature / humidity control).

**Precaution for Storage / Transportation**

1. Product performance and soldered connections may deteriorate if the Products are stored in the places where:
  - [a] the Products are exposed to sea winds or corrosive gases, including Cl<sub>2</sub>, H<sub>2</sub>S, NH<sub>3</sub>, SO<sub>2</sub>, and NO<sub>2</sub>
  - [b] the temperature or humidity exceeds those recommended by ROHM
  - [c] the Products are exposed to direct sunshine or condensation
  - [d] the Products are exposed to high Electrostatic
2. Even under ROHM recommended storage condition, solderability of products out of recommended storage time period may be degraded. It is strongly recommended to confirm solderability before using Products of which storage time is exceeding the recommended storage time period.
3. Store / transport cartons in the correct direction, which is indicated on a carton with a symbol. Otherwise bent leads may occur due to excessive stress applied when dropping of a carton.
4. Use Products within the specified time after opening a humidity barrier bag. Baking is required before using Products of which storage time is exceeding the recommended storage time period.

**Precaution for Product Label**

QR code printed on ROHM Products label is for ROHM's internal use only.

**Precaution for Disposition**

When disposing Products please dispose them properly using an authorized industry waste company.

**Precaution for Foreign Exchange and Foreign Trade act**

Since our Products might fall under controlled goods prescribed by the applicable foreign exchange and foreign trade act, please consult with ROHM representative in case of export.

**Precaution Regarding Intellectual Property Rights**

1. All information and data including but not limited to application example contained in this document is for reference only. ROHM does not warrant that foregoing information or data will not infringe any intellectual property rights or any other rights of any third party regarding such information or data. ROHM shall not be in any way responsible or liable for infringement of any intellectual property rights or other damages arising from use of such information or data.:
2. No license, expressly or implied, is granted hereby under any intellectual property rights or other rights of ROHM or any third parties with respect to the information contained in this document.

**Other Precaution**

1. This document may not be reprinted or reproduced, in whole or in part, without prior written consent of ROHM.
2. The Products may not be disassembled, converted, modified, reproduced or otherwise changed without prior written consent of ROHM.
3. In no event shall you use in any way whatsoever the Products and the related technical information contained in the Products or this document for any military purposes, including but not limited to, the development of mass-destruction weapons.
4. The proper names of companies or products described in this document are trademarks or registered trademarks of ROHM, its affiliated companies or third parties.

**General Precaution**

1. Before you use our Products, you are requested to carefully read this document and fully understand its contents. ROHM shall not be in any way responsible or liable for failure, malfunction or accident arising from the use of any ROHM's Products against warning, caution or note contained in this document.
2. All information contained in this document is current as of the issuing date and subject to change without any prior notice. Before purchasing or using ROHM's Products, please confirm the latest information with a ROHM sales representative.
3. The information contained in this document is provided on an "as is" basis and ROHM does not warrant that all information contained in this document is accurate and/or error-free. ROHM shall not be in any way responsible or liable for any damages, expenses or losses incurred by you or third parties resulting from inaccuracy or errors of or concerning such information.