

## 20MSPS 16-bit CCD Digitiser

### DESCRIPTION

The WM8199 is a 16-bit analogue front end/digitiser IC which processes and digitises the analogue output signals from CCD sensors or Contact Image Sensors (CIS) at pixel sample rates of up to 20MSPS.

The device includes three analogue signal processing channels each of which contains Reset Level Clamping, Correlated Double Sampling and Programmable Gain and Offset adjust functions. Three multiplexers allow single channel processing. The output from each of these channels is time multiplexed into a single high-speed 16-bit Analogue to Digital Converter. The digital output data is available in 8 or 4-bit wide multiplexed format.

An internal 4-bit DAC is supplied for internal reference level generation. This may be used during CDS to reference CIS signals or during Reset Level Clamping to clamp CCD signals. An external reference level may also be supplied. ADC references are generated internally, ensuring optimum performance from the device.

Using an analogue supply voltage of 5V and a digital interface supply of either 5V or 3.3V, the WM8199 typically only consumes 358mW when operating from a single 5V supply.

### FEATURES

- 16-bit ADC
- 20MSPS conversion rate
- 30MSPS conversion rate at 8-bits
- Low power – 358mW typical
- 5V single supply or 5V/3.3V dual supply operation
- Single or 3 channel operation
- Correlated double sampling
- Programmable gain (8-bit resolution)
- Programmable offset adjust (8-bit resolution)
- Programmable clamp voltage
- 8 or 4-bit wide multiplexed data output formats
- Internally generated voltage references
- 28-lead SSOP package
- Serial control interface

### APPLICATIONS

- Flatbed and sheetfeed scanners
- USB compatible scanners
- Multi-function peripherals
- High-performance CCD sensor interface

### BLOCK DIAGRAM

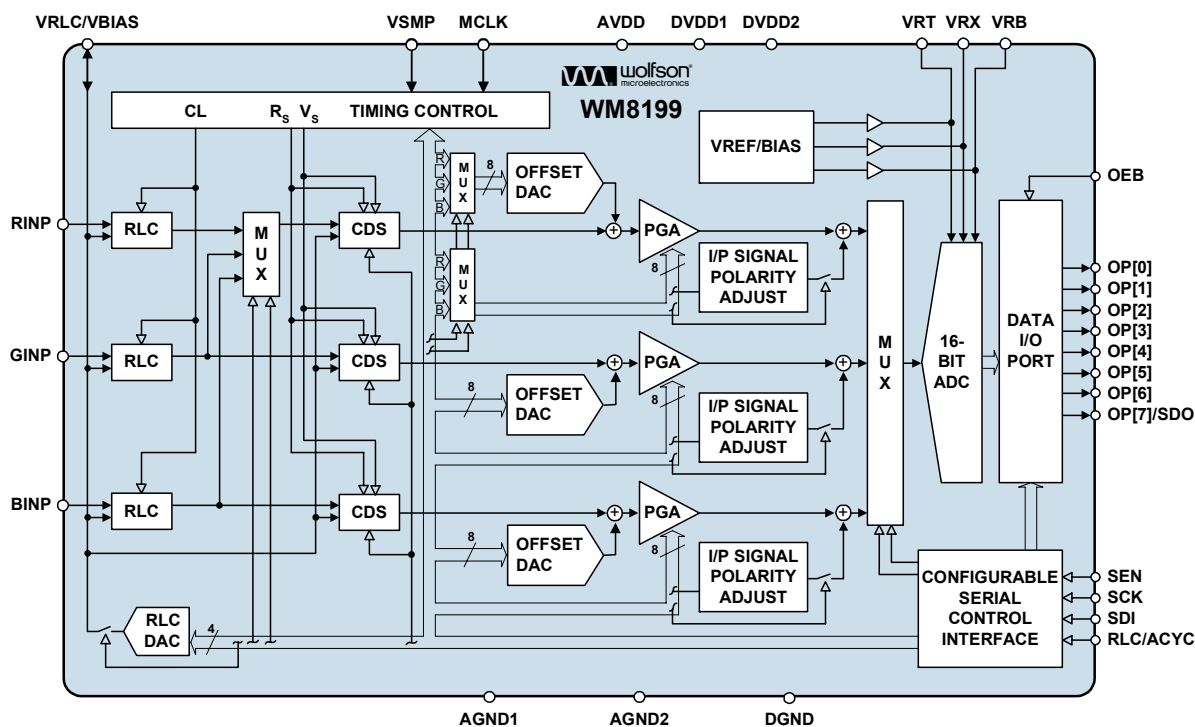

## TABLE OF CONTENTS

<b>DESCRIPTION .....</b>	<b>1</b>
<b>FEATURES.....</b>	<b>1</b>
<b>APPLICATIONS .....</b>	<b>1</b>
<b>BLOCK DIAGRAM .....</b>	<b>1</b>
<b>TABLE OF CONTENTS .....</b>	<b>2</b>
<b>PIN CONFIGURATION.....</b>	<b>3</b>
<b>ORDERING INFORMATION .....</b>	<b>3</b>
<b>PIN DESCRIPTION .....</b>	<b>4</b>
<b>ABSOLUTE MAXIMUM RATINGS.....</b>	<b>5</b>
<b>RECOMMENDED OPERATING CONDITIONS .....</b>	<b>5</b>
<b>THERMAL PERFORMANCE .....</b>	<b>5</b>
<b>ELECTRICAL CHARACTERISTICS .....</b>	<b>6</b>
TYPICAL HIGH SPEED PERFORMANCE.....	8
INPUT VIDEO SAMPLING.....	9
OUTPUT DATA TIMING .....	9
SERIAL INTERFACE .....	10
<b>INTERNAL POWER ON RESET CIRCUIT .....</b>	<b>12</b>
<b>DEVICE DESCRIPTION.....</b>	<b>14</b>
INTRODUCTION.....	14
INPUT SAMPLING.....	14
RESET LEVEL CLAMPING (RLC).....	14
CDS/NON-CDS PROCESSING .....	15
OFFSET ADJUST AND PROGRAMMABLE GAIN.....	16
ADC INPUT BLACK LEVEL ADJUST .....	16
OVERALL SIGNAL FLOW SUMMARY .....	17
CALCULATING OUTPUT FOR ANY GIVEN INPUT .....	17
OUTPUT FORMATS.....	18
CONTROL INTERFACE .....	19
TIMING REQUIREMENTS.....	19
PROGRAMMABLE VSMP DETECT CIRCUIT .....	20
REFERENCES.....	20
POWER SUPPLY .....	20
POWER MANAGEMENT .....	21
LINE-BY-LINE OPERATION .....	21
OPERATING MODES.....	22
OPERATING MODE TIMING DIAGRAMS .....	23
<b>DEVICE CONFIGURATION .....</b>	<b>26</b>
REGISTER MAP .....	26
REGISTER MAP DESCRIPTION .....	27
<b>RECOMMENDED EXTERNAL COMPONENTS .....</b>	<b>30</b>
<b>PACKAGE DIMENSIONS .....</b>	<b>31</b>
<b>IMPORTANT NOTICE .....</b>	<b>32</b>
ADDRESS:.....	32

## PIN CONFIGURATION

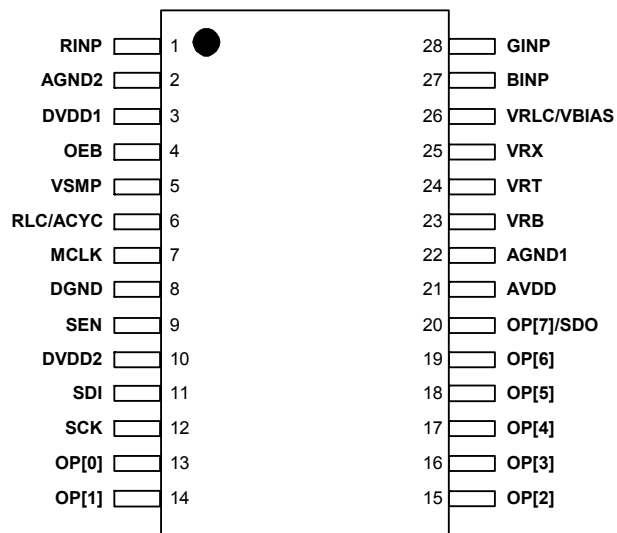

## ORDERING INFORMATION

DEVICE	TEMPERATURE RANGE	PACKAGE	MOISTURE SENSITIVITY LEVEL	PEAK SOLDERING TEMPERATURE
WM8199SCDS/V	0 to 70°C	28-lead SSOP (Pb-free)	MSL3	260°C
WM8199SCDS/RV	0 to 70°C	28-lead SSOP (Pb-free, tape and reel)	MSL3	260°C

**Note:**

Reel quantity = 2,000

## PIN DESCRIPTION

PIN	NAME	TYPE	DESCRIPTION																																																																												
1	RINP	Analogue input	Red channel input video.																																																																												
2	AGND2	Supply	Analogue ground (0V).																																																																												
3	DVDD1	Supply	Digital supply (5V) for logic and clock generator. This must be operated at the same potential as AVDD.																																																																												
4	OEB	Digital input	Output Hi-Z control, all digital outputs disabled when OEB = 1.																																																																												
5	VSMP	Digital input	Video sample synchronisation pulse.																																																																												
6	RLC/ACYC	Digital input	RLC (active high) selects reset level clamp on a pixel-by-pixel basis – tie high if used on every pixel. ACYC autcycles between R, G, B inputs.																																																																												
7	MCLK	Digital input	Master clock. This clock is applied at N times the input pixel rate (N = 2, 3, 6, 8 or any multiple of 2 thereafter depending on input sample mode).																																																																												
8	DGND	Supply	Digital ground (0V).																																																																												
9	SEN	Digital input	Enables the serial interface when high.																																																																												
10	DVDD2	Supply	Digital supply (5V/3.3V), all digital I/O pins.																																																																												
11	SDI	Digital input	Serial data input.																																																																												
12	SCK	Digital input	Serial clock.																																																																												
			Digital multiplexed output data bus. ADC output data (d15:d0) is available in two multiplexed formats as shown, under the control of register MUXOP [1:0] See 'Output Formats' description in Device Description section for further details.																																																																												
			<table border="1" style="width: 100%; border-collapse: collapse;"> <thead> <tr> <th colspan="2">8+8-bit</th> <th colspan="4">4+4+4+4-bit</th> </tr> <tr> <th>A</th> <th>B</th> <th>A</th> <th>B</th> <th>C</th> <th>D</th> </tr> </thead> <tbody> <tr> <td>13</td> <td>OP[0]</td> <td>Digital output</td> <td>d8</td> <td>d0</td> <td></td> <td></td> </tr> <tr> <td>14</td> <td>OP[1]</td> <td>Digital output</td> <td>d9</td> <td>d1</td> <td></td> <td></td> </tr> <tr> <td>15</td> <td>OP[2]</td> <td>Digital output</td> <td>d10</td> <td>d2</td> <td></td> <td></td> </tr> <tr> <td>16</td> <td>OP[3]</td> <td>Digital output</td> <td>d11</td> <td>d3</td> <td></td> <td></td> </tr> <tr> <td>17</td> <td>OP[4]</td> <td>Digital output</td> <td>d12</td> <td>d4</td> <td>d12</td> <td>d8</td> <td>d4</td> <td>d0</td> </tr> <tr> <td>18</td> <td>OP[5]</td> <td>Digital output</td> <td>d13</td> <td>d5</td> <td>d13</td> <td>d9</td> <td>d5</td> <td>d1</td> </tr> <tr> <td>19</td> <td>OP[6]</td> <td>Digital output</td> <td>d14</td> <td>d6</td> <td>d14</td> <td>d10</td> <td>d6</td> <td>d2</td> </tr> <tr> <td>20</td> <td>OP[7]/SDO</td> <td>Digital output</td> <td>d15</td> <td>d7</td> <td>d15</td> <td>d11</td> <td>d7</td> <td>d3</td> </tr> </tbody> </table>	8+8-bit		4+4+4+4-bit				A	B	A	B	C	D	13	OP[0]	Digital output	d8	d0			14	OP[1]	Digital output	d9	d1			15	OP[2]	Digital output	d10	d2			16	OP[3]	Digital output	d11	d3			17	OP[4]	Digital output	d12	d4	d12	d8	d4	d0	18	OP[5]	Digital output	d13	d5	d13	d9	d5	d1	19	OP[6]	Digital output	d14	d6	d14	d10	d6	d2	20	OP[7]/SDO	Digital output	d15	d7	d15	d11	d7	d3
8+8-bit		4+4+4+4-bit																																																																													
A	B	A	B	C	D																																																																										
13	OP[0]	Digital output	d8	d0																																																																											
14	OP[1]	Digital output	d9	d1																																																																											
15	OP[2]	Digital output	d10	d2																																																																											
16	OP[3]	Digital output	d11	d3																																																																											
17	OP[4]	Digital output	d12	d4	d12	d8	d4	d0																																																																							
18	OP[5]	Digital output	d13	d5	d13	d9	d5	d1																																																																							
19	OP[6]	Digital output	d14	d6	d14	d10	d6	d2																																																																							
20	OP[7]/SDO	Digital output	d15	d7	d15	d11	d7	d3																																																																							
			Alternatively, pin OP[7]/SDO may be used to output register read-back data when OEB = 0 and SEN has been pulsed high. See Serial Interface description in Device Description section for further details.																																																																												
21	AVDD	Supply	Analogue supply (5V). This must be operated at the same potential as DVDD1.																																																																												
22	AGND1	Supply	Analogue ground (0V).																																																																												
23	VRB	Analogue output	Lower reference voltage. This pin must be connected to AGND via a decoupling capacitor.																																																																												
24	VRT	Analogue output	Upper reference voltage. This pin must be connected to AGND via a decoupling capacitor.																																																																												
25	VRX	Analogue output	Input return bias voltage. This pin must be connected to AGND via a decoupling capacitor.																																																																												
26	VRRLC/VBIAS	Analogue I/O	Selectable analogue output voltage for RLC or single-ended bias reference. This pin would typically be connected to AGND via a decoupling capacitor. VRRLC can be externally driven if programmed Hi-Z.																																																																												
27	BINP	Analogue input	Blue channel input video.																																																																												
28	GINP	Analogue input	Green channel input video.																																																																												

## ABSOLUTE MAXIMUM RATINGS

Absolute Maximum Ratings are stress ratings only. Permanent damage to the device may be caused by continuously operating at or beyond these limits. Device functional operating limits and guaranteed performance specifications are given under Electrical Characteristics at the test conditions specified.



ESD Sensitive Device. This device is manufactured on a CMOS process. It is therefore generically susceptible to damage from excessive static voltages. Proper ESD precautions must be taken during handling and storage of this device.

Wolfson tests its package types according to IPC/JEDEC J-STD-020B for Moisture Sensitivity to determine acceptable storage conditions prior to surface mount assembly. These levels are:

MSL1 = unlimited floor life at <30°C / 85% Relative Humidity. Not normally stored in moisture barrier bag.

MSL2 = out of bag storage for 1 year at <30°C / 60% Relative Humidity. Supplied in moisture barrier bag.

MSL3 = out of bag storage for 168 hours at <30°C / 60% Relative Humidity. Supplied in moisture barrier bag.

The Moisture Sensitivity Level for each package type is specified in Ordering Information.

CONDITION	MIN	MAX
Analogue supply voltage: AVDD	GND - 0.3V	GND + 7V
Digital supply voltages: DVDD1 – 2	GND - 0.3V	GND + 7V
Digital ground: DGND	GND - 0.3V	GND + 0.3V
Analogue grounds: AGND1 – 2	GND - 0.3V	GND + 0.3V
Digital inputs, digital outputs and digital I/O pins	GND - 0.3V	DVDD2 + 0.3V
Analogue inputs (RINP, GINP, BINP)	GND - 0.3V	AVDD + 0.3V
Other pins	GND - 0.3V	AVDD + 0.3V
Operating temperature range: T <sub>A</sub>	0°C	+70°C
Storage temperature after soldering	-65°C	+150°C

### Notes:

- GND denotes the voltage of any ground pin.
- AGND1, AGND2 and DGND pins are intended to be operated at the same potential. Differential voltages between these pins will degrade performance.

## RECOMMENDED OPERATING CONDITIONS

CONDITION	SYMBOL	MIN	TYP	MAX	UNITS	
Operating temperature range	T <sub>A</sub>	0		70	°C	
Analogue supply voltage	AVDD	4.75	5.0	5.25	V	
Digital core supply voltage	DVDD1	4.75	5.0	5.25	V	
Digital I/O supply voltage	5V I/O	DVDD2	4.75	5.0	5.25	V
	3.3V I/O	DVDD2	2.97	3.3	3.63	V

## THERMAL PERFORMANCE

PARAMETER	SYMBOL	TEST CONDITIONS	MIN	TYP	MAX	UNIT
<b>Performance</b>						
Thermal resistance – junction to case	R <sub>θJC</sub>	T <sub>ambient</sub> = 25°C		23.9		°C/W
Thermal resistance – junction to ambient	R <sub>θJA</sub>			67.1		°C/W

### Notes:

- Figures given are for package mounted on 4-layer FR4 according to JESD51-5 and JESD51-7.

## ELECTRICAL CHARACTERISTICS

### Test Conditions

AVDD = DVDD1 = 5.0V, DVDD2 = 3.3V, AGND = DGND = 0V, T<sub>A</sub> = 25°C, MCLK = 32MHz unless otherwise stated.

PARAMETER	SYMBOL	TEST CONDITIONS	MIN	TYP	MAX	UNIT
<b>Overall System Specification (including 16-bit ADC, PGA, Offset and CDS functions)</b>						
Conversion rate			16			MSPS
Full-scale input voltage range (see Note 1)		Max Gain Min Gain		0.4 4.08		Vp-p Vp-p
Input signal limits (see Note 2)	V <sub>IN</sub>		0		AVDD	V
Full-scale transition error		Gain = 0dB; PGA[7:0] = 4B(hex)		20		mV
Zero-scale transition error		Gain = 0dB; PGA[7:0] = 4B(hex)		20		mV
Differential non-linearity	DNL			1.25		LSB
Integral non-linearity	INL			36		LSB
Channel to channel gain matching				1		%
Total output noise		Min Gain Max Gain		5 25		LSB rms LSB rms
<b>References</b>						
Upper reference voltage	VRT			2.85		V
Lower reference voltage	VRB			1.35		V
Input return bias voltage	VRX			1.65		V
Diff. reference voltage (VRT-VRB)	V <sub>RTB</sub>		1.4	1.5	1.6	V
Output resistance VRT, VRB, VRX				1.6		Ω
<b>VRLC/Reset-Level Clamp (RLC)</b>						
RLC switching impedance				50		Ω
VRLC short-circuit current				2		mA
VRLC output resistance				2		Ω
VRLC Hi-Z leakage current		VRLC = 0 to AVDD			1	μA
RLCDAC resolution				4		bits
RLCDAC step size, RLCDAC = 0	V <sub>RLCSTEP</sub>	AVDD=5V		0.25		V/step
RLCDAC step size, RLCDAC = 1	V <sub>RLCSTEP</sub>			0.17		V/step
RLCDAC output voltage at code 0(hex), RLCDACRNG = 0	V <sub>RLCBOT</sub>	AVDD=5V		0.39		V
RLCDAC output voltage at code 0(hex), RLCDACRNG = 1	V <sub>RLCBOT</sub>			0.26		V
RLCDAC output voltage at code F(hex) RLCDACRNG, = 0	V <sub>RLCTOP</sub>	AVDD=5V		4.14		V
RLCDAC output voltage at code F(hex), RLCDACRNG = 1	V <sub>RLCTOP</sub>			2.81		V
VRLC deviation				25		mV
<b>Offset DAC, Monotonicity Guaranteed</b>						
Resolution				8		bits
Differential non-linearity	DNL			0.1	0.5	LSB
Integral non-linearity	INL			0.25	1	LSB
Step size				2.02		mV/step
Output voltage		Code 00(hex) Code FF(hex)		-260 +260		mV mV

### Notes:

1. **Full-scale input voltage** denotes the peak input signal amplitude that can be gained to match the ADC full-scale input range.
2. **Input signal limits** are the limits within which the full-scale input voltage signal must lie.

**Test Conditions**AVDD = DVDD1 = 5.0V, DVDD2 = 3.3V, AGND = DGND = 0V, T<sub>A</sub> = 25°C, MCLK = 32MHz unless otherwise stated.

PARAMETER	SYMBOL	TEST CONDITIONS	MIN	TYP	MAX	UNIT
<b>Programmable Gain Amplifier</b>						
Resolution				8		bits
Gain				$\frac{208}{283 - \text{PGA}[7:0]}$		V/V
Max gain, each channel	G <sub>MAX</sub>			7.43		V/V
Min gain, each channel	G <sub>MIN</sub>			0.74		V/V
Gain error, each channel				1		%
<b>Analogue to Digital Converter</b>						
Resolution				16		bits
Speed			16			MSPS
Full-scale input range (2*(VRT-VRB))				3		V
<b>DIGITAL SPECIFICATIONS</b>						
<b>Digital Inputs</b>						
High level input voltage	V <sub>IH</sub>		0.8 * DVDD2			V
Low level input voltage	V <sub>IL</sub>				0.2 * DVDD2	V
High level input current	I <sub>IH</sub>				1	µA
Low level input current	I <sub>IL</sub>				1	µA
Input capacitance	C <sub>I</sub>			5		pF
<b>Digital Outputs</b>						
High level output voltage	V <sub>OH</sub>	I <sub>OH</sub> = 1mA	DVDD2 - 0.5			V
Low level output voltage	V <sub>OL</sub>	I <sub>OL</sub> = 1mA			0.5	V
High impedance output current	I <sub>OZ</sub>				1	µA
<b>Digital IO Pins</b>						
Applied high level input voltage	V <sub>IH</sub>		0.8 * DVDD2			V
Applied low level input voltage	V <sub>IL</sub>				0.2 * DVDD2	V
High level output voltage	V <sub>OH</sub>	I <sub>OH</sub> = 1mA	DVDD2 - 0.5			V
Low level output voltage	V <sub>OL</sub>	I <sub>OL</sub> = 1mA			0.5	V
Low level input current	I <sub>IL</sub>				1	µA
High level input current	I <sub>IH</sub>				1	µA
Input capacitance	C <sub>I</sub>			5		pF
High impedance output current	I <sub>OZ</sub>				1	µA
<b>Supply Currents</b>						
Total supply current – active (Three channel mode)		MCLK = 32Hz		72		mA
Total supply current – active (Single channel mode)		LINEBYLINE = 1 MCLK = 32MHz		56		mA
Total analogue supply current – active (Three channel mode)	I <sub>AVDD</sub>	MCLK = 32MHz		65		mA
Total analogue supply current – active (Single channel mode)	I <sub>AVDD</sub>	LINEBYLINE = 1 MCLK = 32MHz		49		mA
Digital core supply current, DVDD1 – active (note 1)		MCLK = 32MHz		5		mA
Digital I/O supply current, DVDD2 – active (note 1)		MCLK = 32MHz		2		mA
Supply current – full power down mode				300		µA

**Notes:**

Digital supply current depends on the capacitive load connected to the WM8199 output pins and the clock rate applied to MCLK. This data is based on a load of approximately 10pF per output pin and MCLK = 16MHz.

**TYPICAL HIGH SPEED PERFORMANCE**

The WM8199 is capable of operating at speeds greater than 20MSPS with a reduction in linearity. Figures 1 and 2 below show the typical 8-bit performance at 30MSPS.

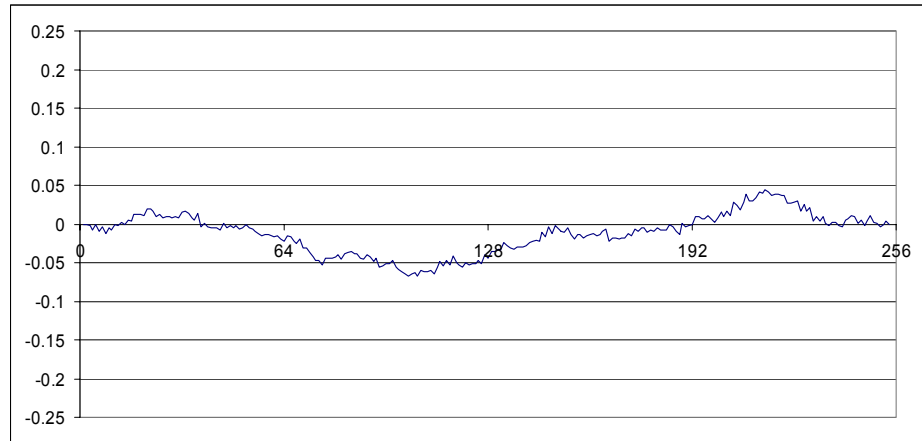

**Figure 1 Typical 8-bit INL Characteristic at 30MSPS**

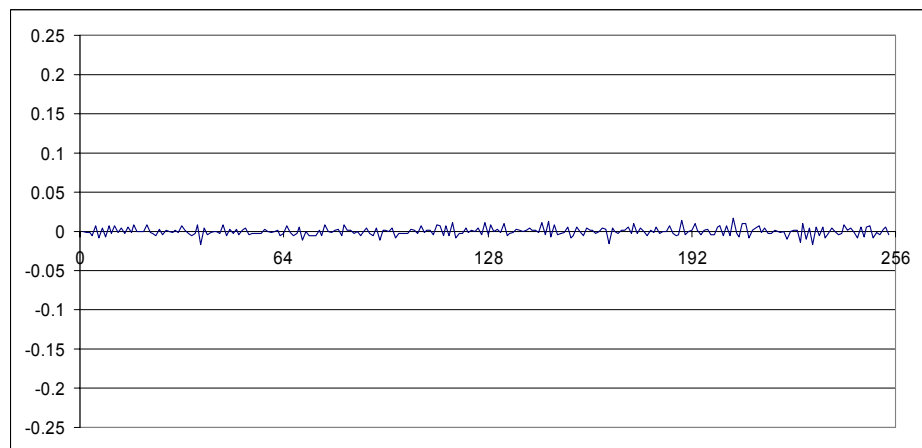

**Figure 2 Typical 8-bit DNL Characteristic at 30MSPS**



**INPUT VIDEO SAMPLING**

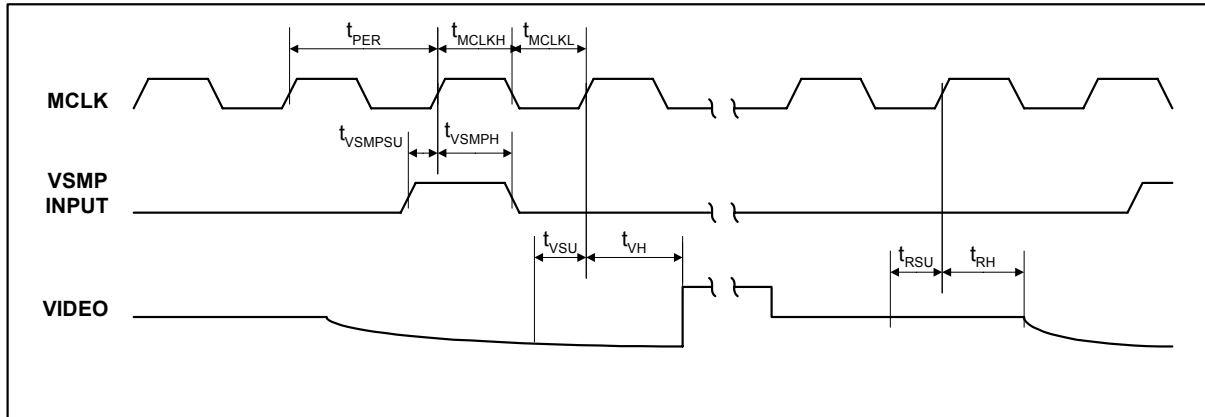

**Figure 3 Input Video Timing**

**Note:**

1. See Page 20 (Programmable VSMP Detect Circuit) for video sampling description.

**Test Conditions**

AVDD = DVDD1 = 5.0V, DVDD2 = 3.3V, AGND = DGND = 0V, T<sub>A</sub> = 25°C unless otherwise stated.

PARAMETER	SYMBOL	TEST CONDITIONS	MIN	TYP	MAX	UNITS
MCLK period	t <sub>PER</sub>		25			ns
MCLK high period	t <sub>MCLKH</sub>		11.3	14.1		ns
MCLK low period	t <sub>MCLKL</sub>		11.3	14.1		ns
VSMP set-up time	t <sub>VSMPHU</sub>		5			ns
VSMP hold time	t <sub>VSMPH</sub>		3			ns
Video level set-up time	t <sub>VSU</sub>		11			ns
Video level hold time	t <sub>VH</sub>		4			ns
Reset level set-up time	t <sub>RSU</sub>		11			ns
Reset level hold time	t <sub>RH</sub>		4			ns

**Notes:**

1. t<sub>VSU</sub> and t<sub>RSU</sub> denote the set-up time required after the input video signal has settled.
2. Parameters are measured at 50% of the rising/falling edge.

**OUTPUT DATA TIMING**

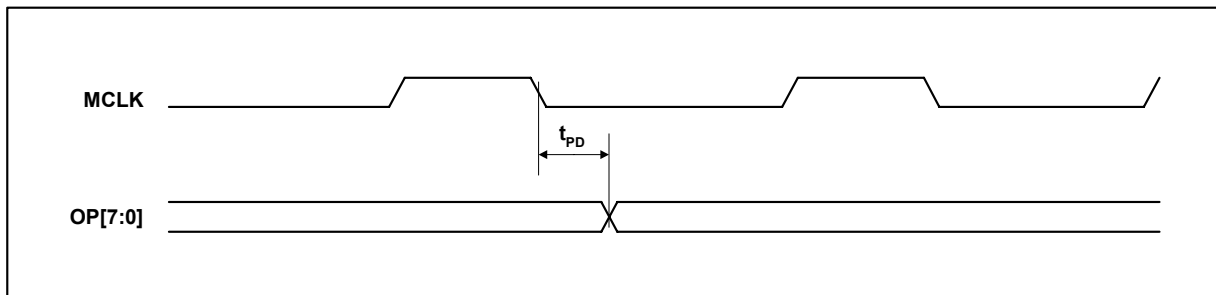

**Figure 4 Output Data Timing**

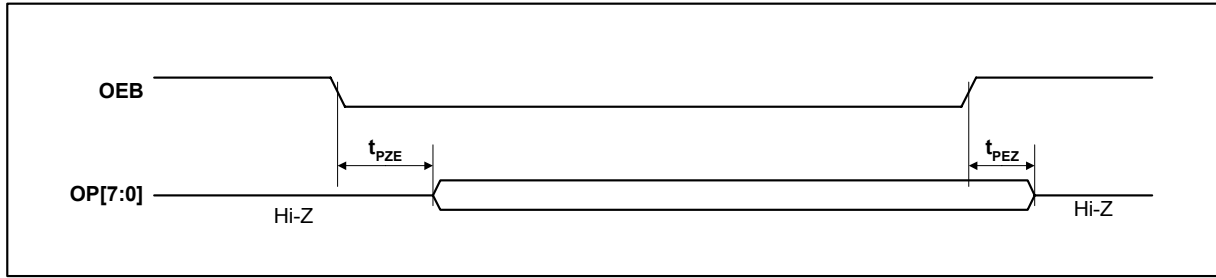

Figure 5 Output Data Enable Timing

**Test Conditions**

AVDD = DVDD1 = 5.0V, DVDD2 = 3.3V, AGND = DGND = 0V, T<sub>A</sub> = 25°C unless otherwise stated.

PARAMETER	SYMBOL	TEST CONDITIONS	MIN	TYP	MAX	UNITS
Output propagation delay	t <sub>PD</sub>	I <sub>OH</sub> = 1mA, I <sub>OL</sub> = 1mA		18	30	ns
Output enable time	t <sub>PZE</sub>				20	ns
Output disable time	t <sub>PEZ</sub>				15	ns

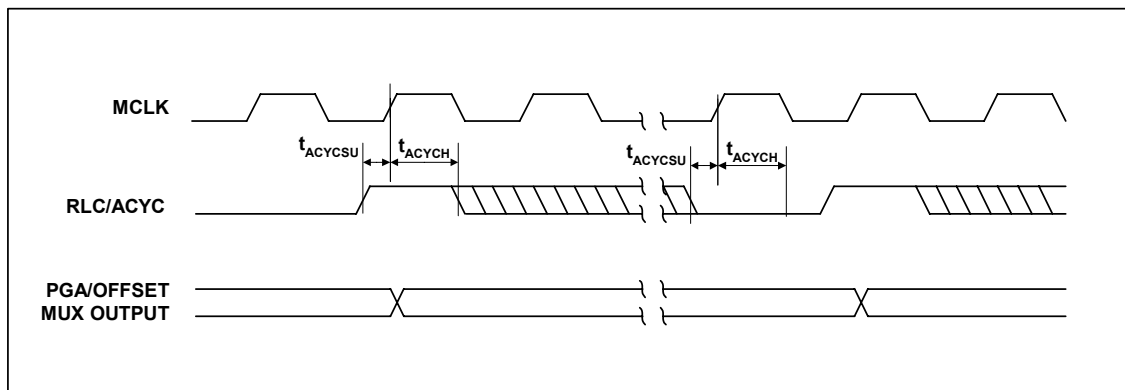

Figure 6 Auto Cycle Timing

**Test Conditions**

AVDD = DVDD1 = 5.0V, DVDD2 = 3.3V, AGND = DGND = 0V, T<sub>A</sub> = 25°C unless otherwise stated.

PARAMETER	SYMBOL	TEST CONDITIONS	MIN	TYP	MAX	UNITS
Auto Cycle set-up time	t <sub>ACYCSU</sub>		5			ns
Auto Cycle hold time	t <sub>ACYCH</sub>		3			ns

**SERIAL INTERFACE**

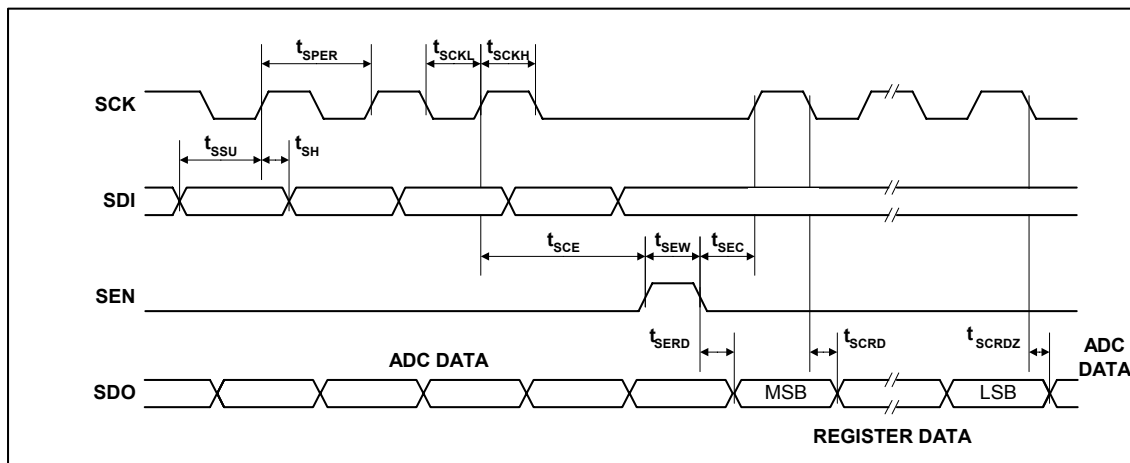

Figure 7 Serial Interface Timing

**Test Conditions**

AVDD = DVDD1 = 5.0V, DVDD2 = 23.3V, AGND = DGND = 0V, T<sub>A</sub> = 25°C unless otherwise stated.

PARAMETER	SYMBOL	TEST CONDITIONS	MIN	TYP	MAX	UNITS
SCK period	t <sub>SPER</sub>		41.6			ns
SCK high	t <sub>SCKH</sub>		18.8			ns
SCK low	t <sub>SCKL</sub>		18.8			ns
SDI set-up time	t <sub>SSU</sub>		6			ns
SDI hold time	t <sub>SH</sub>		6			ns
SCK to SEN set-up time	t <sub>SCE</sub>		12			ns
SEN to SCK set-up time	t <sub>SEC</sub>		12			ns
SEN pulse width	t <sub>SEW</sub>		25			ns
SEN low to SDO = Register data	t <sub>SERD</sub>				30	ns
SCK low to SDO = Register data	t <sub>SCRD</sub>				30	ns
SCK low to SDO = ADC data	t <sub>SCRZ</sub>				30	ns

**Note:**

- Parameters are measured at 50% of the rising/falling edge

## INTERNAL POWER ON RESET CIRCUIT

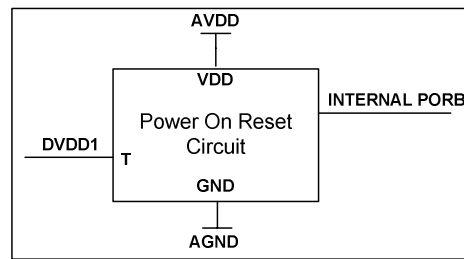

Figure 8 Internal Power On Reset Circuit Schematic

The WM8199 includes an internal Power-On-Reset Circuit, as shown in Figure 8, which is used to reset the digital logic into a default state after power up. The POR circuit is powered from AVDD and monitors DVDD1. It asserts PORB low if AVDD or DVDD1 is below a minimum threshold.

The power supplies can be brought up in any order but is important that either AVDD is brought up and is stable before DVDD comes up or vice versa as shown in Figure 9 and Figure 10.

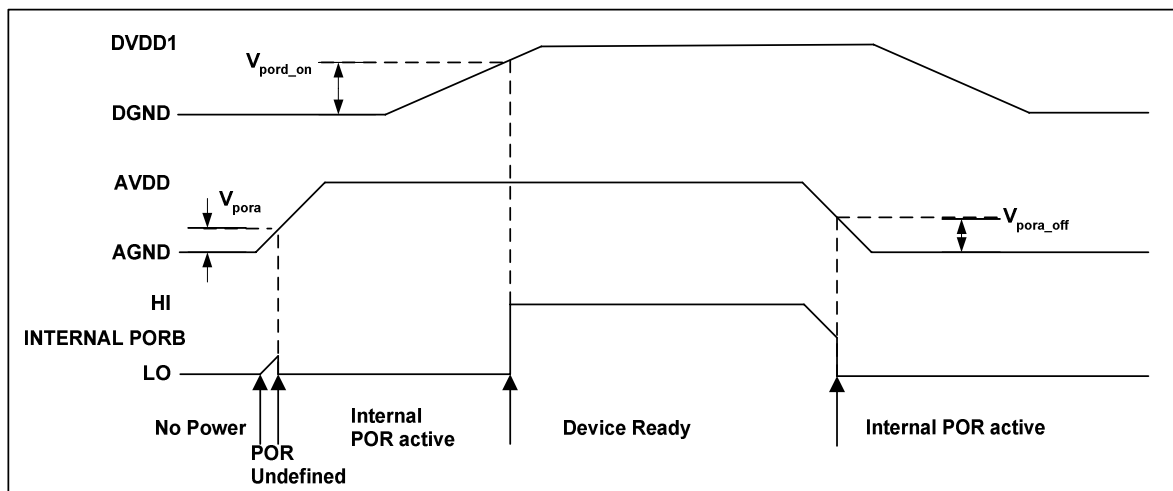

Figure 9 Typical Power up Sequence where AVDD is Powered before DVDD1

Figure 9 shows a typical power-up sequence where AVDD is powered up first. When AVDD rises above the minimum threshold,  $V_{pora}$ , there is enough voltage for the circuit to guarantee PORB is asserted low and the chip is held in reset. In this condition, all writes to the control interface are ignored. Now AVDD is at full supply level. Next DVDD1 rises to  $V_{pord\_on}$  and PORB is released high and all registers are in their default state and writes to the control interface may take place.

On power down, where AVDD falls first, PORB is asserted low whenever AVDD drops below the minimum threshold  $V_{pora\_off}$ .

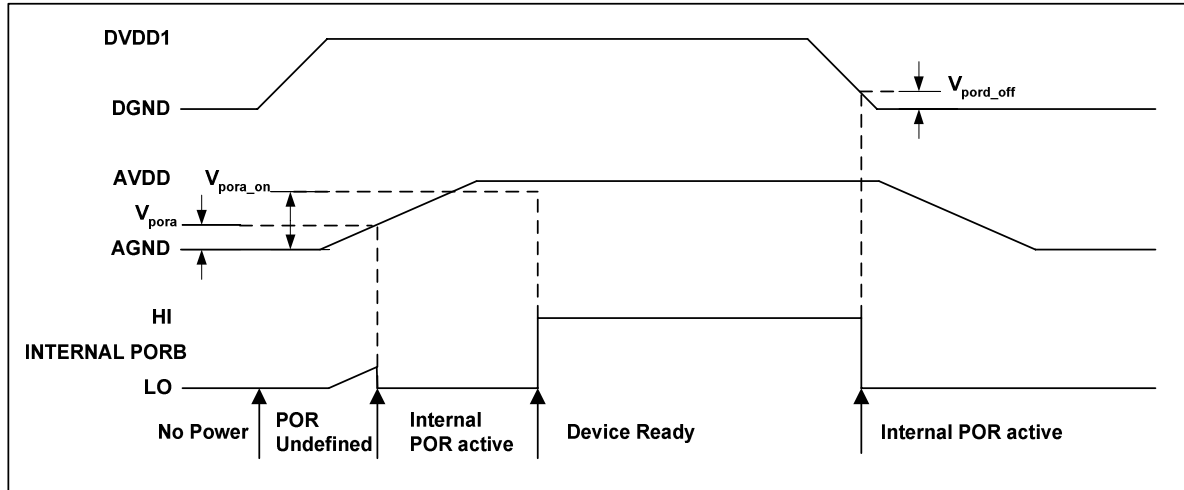

Figure 10 Typical Power up Sequence where DVDD1 is Powered before AVDD

Figure 10 shows a typical power-up sequence where DVDD1 is powered up first. It is assumed that DVDD1 is already up to specified operating voltage. When AVDD goes above the minimum threshold,  $V_{pora}$ , there is enough voltage for the circuit to guarantee PORB is asserted low and the chip is held in reset. In this condition, all writes to the control interface are ignored. When AVDD rises to  $V_{pora\_on}$ , PORB is released high and all registers are in their default state and writes to the control interface may take place.

On power down, where DVDD1 falls first, PORB is asserted low whenever DVDD1 drops below the minimum threshold  $V_{pord\_off}$ .

SYMBOL	TYP	UNIT
$V_{pora}$	0.6	V
$V_{pora\_on}$	1.2	V
$V_{pora\_off}$	0.6	V
$V_{pord\_on}$	0.7	V
$V_{pord\_off}$	0.6	V

Table 1 Typical POR Operation (typical values, not tested)

**Note:** It is recommended that every time power is cycled to the WM8199 a software reset is written to the software register to ensure that the contents of the control registers are at their default values before carrying out any other register writes.

## DEVICE DESCRIPTION

### INTRODUCTION

A block diagram of the device showing the signal path is presented on Page 1.

The WM8199 samples up to three inputs (RINP, GINP and BINP) simultaneously. The device then processes the sampled video signal with respect to the video reset level or an internally/externally generated reference level using either one or three processing channels.

Each processing channel consists of an Input Sampling block with optional Reset Level Clamping (RLC) and Correlated Double Sampling (CDS), an 8-bit programmable offset DAC and an 8-bit Programmable Gain Amplifier (PGA).

The ADC then converts each resulting analogue signal to a 16-bit digital word. The digital output from the ADC is presented on an 8-bit wide bi-directional bus, with optional 8 or 4-bit multiplexed formats.

On-chip control registers determine the configuration of the device, including the offsets and gains applied to each channel. These registers are programmable via a serial interface.

### INPUT SAMPLING

The WM8199 can sample and process one to three inputs through one or three processing channels as follows:

**Colour Pixel-by-Pixel:** The three inputs (RINP, GINP and BINP) are simultaneously sampled for each pixel and a separate channel processes each input. The signals are then multiplexed into the ADC, which converts all three inputs within the pixel period.

**Monochrome:** A single chosen input (RINP, GINP, or BINP) is sampled, processed by the corresponding channel, and converted by the ADC. The choice of input and channel can be changed via the control interface, e.g. on a line-by-line basis if required.

**Colour Line-by-Line:** A single chosen input (RINP, GINP, or BINP) is sampled and multiplexed into the red channel for processing before being converted by the ADC. The input selected can be switched in turn (RINP → GINP → BINP → RINP...) together with the PGA and Offset DAC control registers by pulsing the RLC/ACYC pin. This is known as auto-cycling. Alternatively, other sampling sequences can be generated via the control registers. This mode causes the blue and green channels to be powered down. Refer to the Line-by-Line Operation section for more details.

### RESET LEVEL CLAMPING (RLC)

To ensure that the signal applied to the WM8199 lies within its input range (0V to AVDD) the CCD output signal is usually level shifted by coupling through a capacitor,  $C_{IN}$ . The RLC circuit clamps the WM8199 side of this capacitor to a suitable voltage during the CCD reset period.

A typical input configuration is shown in Figure 11. An internal clamp pulse, CL, is generated from MCLK and VSMP by the Timing Control Block. When CL is active the voltage on the WM8199 side of  $C_{IN}$ , at RINP, is forced to the VRLC/VBIAS voltage ( $V_{VRLC}$ ) by closing of switch 1. When the CL pulse turns off switch 1 opens, the voltage at RINP initially remains at  $V_{VRLC}$  but any subsequent variation in sensor voltage (from reset to video level) will couple through  $C_{IN}$  to RINP.

RLC is compatible with both CDS and non-CDS operating modes, as selected by switch 2. Refer to the CDS/non-CDS Processing section.

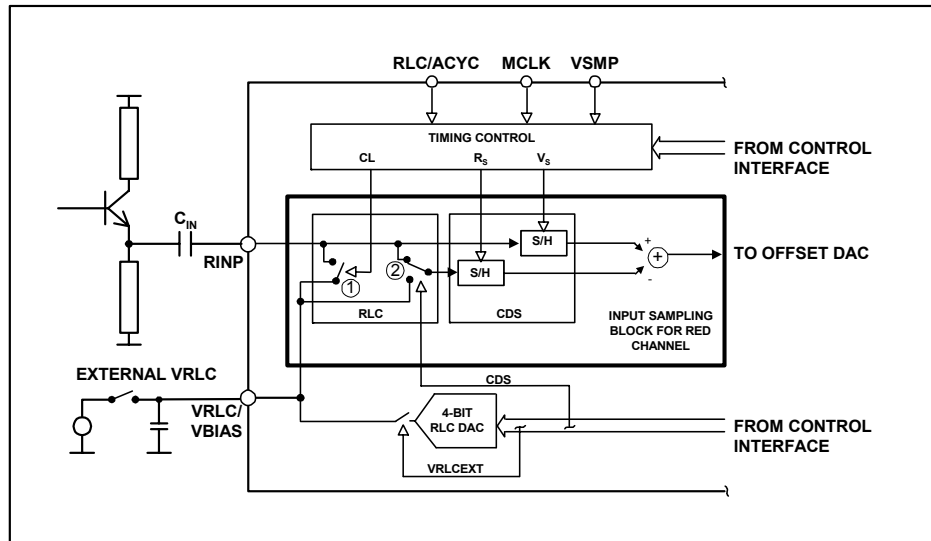
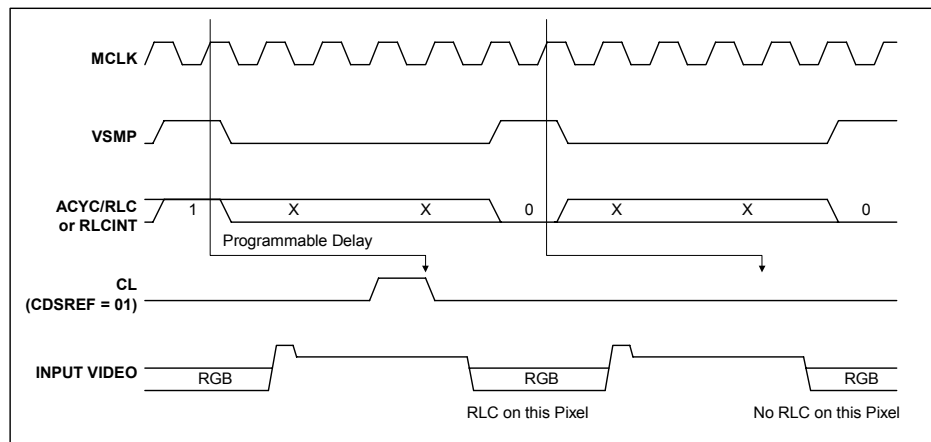

**Figure 11 Reset Level Clamping and CDS Circuitry**

If auto-cycling is not required, RLC can be selected by pin RLC/ACYC. Figure 12 illustrates control of RLC for a typical CCD waveform, with CL applied during the reset period.

The input signal applied to the RLC/ACYC pin is sampled on the positive edge of MCLK that occurs during each VSMP pulse. The sampled level, high (or low) controls the presence (or absence) of the internal CL pulse on the next reset level. The position of CL can be adjusted by using control bits CDSREF[1:0] (Figure 13).

If auto-cycling is required, pin RLC/ACYC is no longer available for this function and control bit RLCINT determines whether clamping is applied.



**Figure 12 Relationship of RLC Pin, MCLK and VSMP to Internal Clamp Pulse, CL**

The VRLC/VBIAS pin can be driven internally by a 4-bit DAC (RLCDAC) by writing to control bits RLCV[3:0]. The RLCDAC range and step size may be increased by writing to control bit RLCDACRNG. Alternatively, the VRLC/VBIAS pin can be driven externally by writing to control bit VRLCEXT to disable the RLCDAC and then applying a d.c. voltage to the pin.

**CDS/NON-CDS PROCESSING**

For CCD type input signals, the signal may be processed using CDS, which will remove pixel-by-pixel common mode noise. For CDS operation, the video level is processed with respect to the video reset level, regardless of whether RLC has been performed. To sample using CDS, control bit CDS must be set to 1 (default), this sets switch 2 into the position shown in (Figure 11) and causes the signal reference to come from the video reset level. The time at which the reset level is sampled, by clock  $R_s/CL$ , is adjustable by programming control bits CDSREF[1:0], as shown in Figure 13.

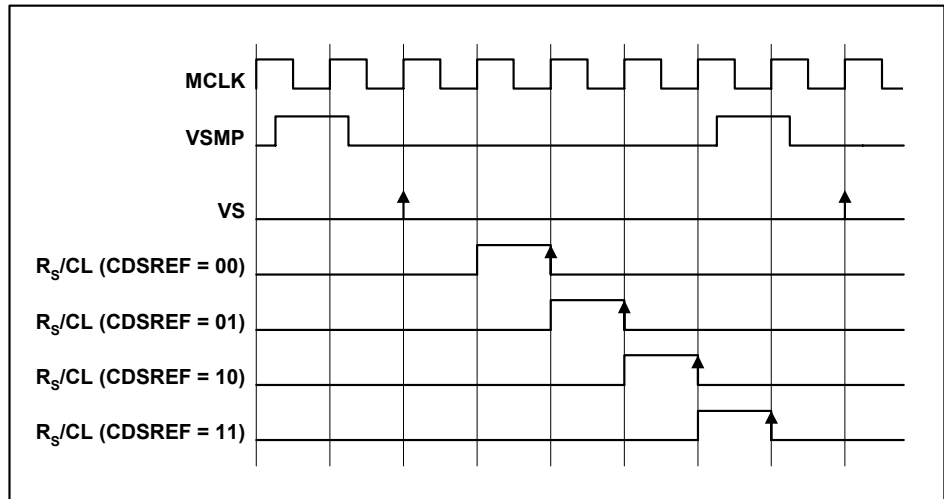

Figure 13 Reset Sample and Clamp Timing

For CIS type sensor signals, non-CDS processing is used. In this case, the video level is processed with respect to the voltage on pin VRLC/VBIAS, generated internally or externally as described above. The VRLC/VBIAS pin is sampled by  $R_s$  at the same time as  $V_s$  samples the video level in this mode; non-CDS processing is achieved by setting switch 2 in the lower position, CDS=0.

### OFFSET ADJUST AND PROGRAMMABLE GAIN

The output from the CDS block is a differential signal, which is added to the output of an 8-bit Offset DAC to compensate for offsets and then amplified by an 8-bit PGA. The gain and offset for each channel are independently programmable by writing to control bits DAC[7:0] and PGA[7:0].

The gain characteristic of the WM8199 PGA is shown in Figure 14. Figure 15 shows the maximum device input voltage that can be gained up to match the ADC full-scale input range (3V).

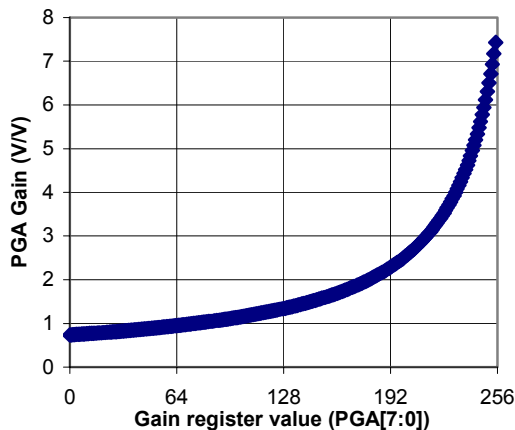

Figure 14 PGA Gain Characteristic

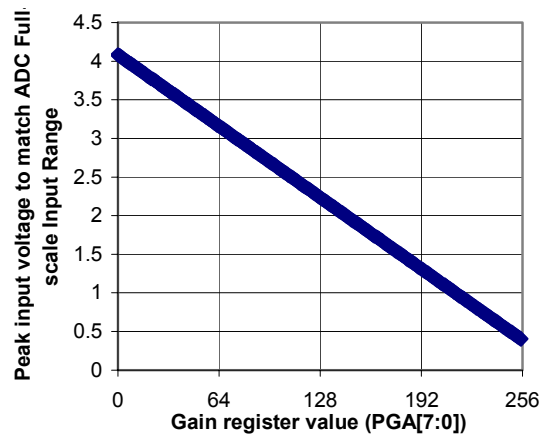

Figure 15 Peak Input Voltage to Match ADC Full-scale Range

In colour line-by-line mode the gain and offset coefficients for each colour can be multiplexed in order (Red → Green → Blue → Red...) by pulsing the ACYC/RLC pin, or controlled via the FME, ACYCNRLC and INTM[1:0] bits. Refer to the Line-by-Line Operation section for more details.

### ADC INPUT BLACK LEVEL ADJUST

The output from the PGA should be offset to match the full-scale range of the ADC (3V). For negative-going input video signals, a black level (zero differential) output from the PGA should be offset to the top of the ADC range by setting register bits PGAFS[1:0]=10. For positive going input signal the black level should be offset to the bottom of the ADC range by setting PGAFS[1:0]=11. Bipolar input video is accommodated by setting PGAFS[1:0]=00 or PGAFS[1:0]=01 (zero differential input voltage gives mid-range ADC output).



**OVERALL SIGNAL FLOW SUMMARY**

Figure 16 represents the processing of the video signal through the WM8199.

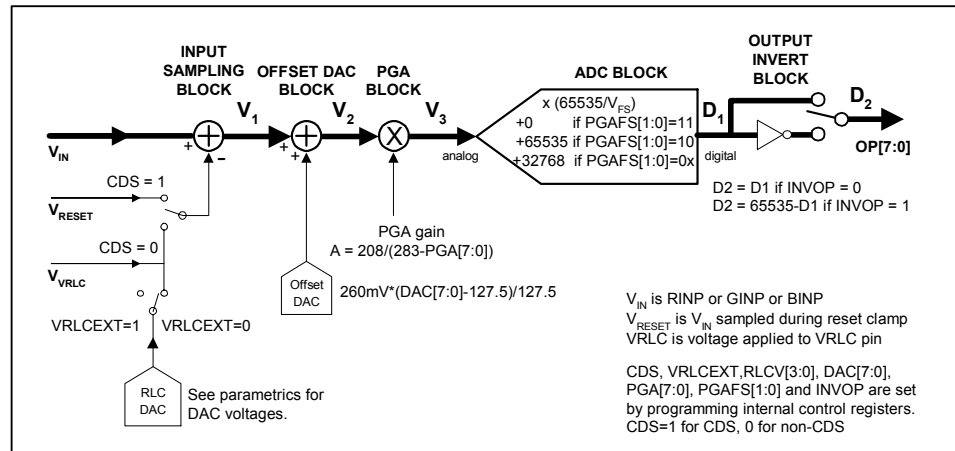

**Figure 16 Overall Signal Flow**

The **INPUT SAMPLING BLOCK** produces an effective input voltage  $V_1$ . For CDS, this is the difference between the input video level  $V_{IN}$  and the input reset level  $V_{RESET}$ . For non-CDS this is the difference between the input video level  $V_{IN}$  and the voltage on the VRLC/VBIAS pin,  $V_{VRLC}$ , optionally set via the RLC DAC.

The **OFFSET DAC BLOCK** then adds the amount of fine offset adjustment required to move the black level of the input signal towards 0V, producing  $V_2$ .

The **PGA BLOCK** then amplifies the white level of the input signal to maximise the ADC range, outputting voltage  $V_3$ .

The **ADC BLOCK** then converts the analogue signal,  $V_3$ , to a 16-bit unsigned digital output,  $D_1$ .

The digital output is then inverted, if required, through the **OUTPUT INVERT BLOCK** to produce  $D_2$ .

**CALCULATING OUTPUT FOR ANY GIVEN INPUT**

The following equations describe the processing of the video and reset level signals through the WM8199. The Values of  $V_1$ ,  $V_2$  and  $V_3$  are often calculated in reverse order during device setup. The PGA value is written first to set the input Voltage range, the Offset DAC is then adjusted to compensate for any Black/Reset level offsets and finally the RLC DAC value is set to position the reset level correctly during operation.

Note: Refer to WAN0123 for detailed information on device calibration procedures.

**INPUT SAMPLING BLOCK: INPUT SAMPLING AND REFERENCING**

If CDS = 1, (i.e. CDS operation) the previously sampled reset level,  $V_{RESET}$ , is subtracted from the input video.

$$V_1 = V_{IN} - V_{RESET} \dots\dots\dots \text{Eqn. 1}$$

If CDS = 0, (non-CDS operation) the simultaneously sampled voltage on pin VRLC is subtracted instead.

$$V_1 = V_{IN} - V_{VRLC} \dots\dots\dots \text{Eqn. 2}$$

If VRLCEXT = 1,  $V_{VRLC}$  is an externally applied voltage on pin VRLC/VBIAS.

If VRLCEXT = 0,  $V_{VRLC}$  is the output from the internal RLC DAC.

$$V_{VRLC} = (V_{RLCSTEP} * RLCV[3:0]) + V_{RLCBOOT} \dots\dots\dots \text{Eqn. 3}$$

$V_{RLCSTEP}$  is the step size of the RLC DAC and  $V_{RLCBOOT}$  is the minimum output of the RLC DAC.

**OFFSET DAC BLOCK: OFFSET (BLACK-LEVEL) ADJUST**

The resultant signal  $V_1$  is added to the Offset DAC output.

$$V_2 = V_1 + \{260\text{mV} * (\text{DAC}[7:0] - 127.5)\} / 127.5 \dots\dots\dots \text{Eqn. 4}$$

**PGA NODE: GAIN ADJUST**

The signal is then multiplied by the PGA gain,

$$V_3 = V_2 * 208 / (283 - \text{PGA}[7:0]) \dots\dots\dots \text{Eqn. 5}$$

**ADC BLOCK: ANALOGUE-DIGITAL CONVERSION**

The analogue signal is then converted to a 16-bit unsigned number, with input range configured by PGAFS[1:0].

$$D_1[15:0] = \text{INT}\{ (V_3 / V_{FS}) * 65535\} + 32767 \quad \text{PGAFS}[1:0] = 00 \text{ or } 01 \dots\dots \text{Eqn. 6}$$

$$D_1[15:0] = \text{INT}\{ (V_3 / V_{FS}) * 65535\} \quad \text{PGAFS}[1:0] = 11 \dots\dots\dots \text{Eqn. 7}$$

$$D_1[15:0] = \text{INT}\{ (V_3 / V_{FS}) * 65535\} + 65535 \quad \text{PGAFS}[1:0] = 10 \dots\dots\dots \text{Eqn. 8}$$

where the ADC full-scale range,  $V_{FS} = 3\text{V}$

**OUTPUT INVERT BLOCK: POLARITY ADJUST**

The polarity of the digital output may be inverted by control bit INVOP.

$$D_2[15:0] = D_1[15:0] \quad (\text{INVOP} = 0) \dots\dots\dots \text{Eqn. 9}$$

$$D_2[15:0] = 65535 - D_1[15:0] \quad (\text{INVOP} = 1) \dots\dots\dots \text{Eqn. 10}$$

**OUTPUT FORMATS**

The digital data output from the ADC is available to the user in 8 or 4-bit wide multiplexed formats by setting control bit MUXOP[1:0]. Latency of valid output data with respect to VSMP is programmable by writing to control bits DEL[1:0]. The latency for each mode is shown in the Operating Mode Timing Diagrams section.

Figure 17 shows the output data formats for Modes 1 – 2 and 4 – 6. Figure 18 shows the output data formats for Mode 3. Table 2 summarises the output data obtained for each format.

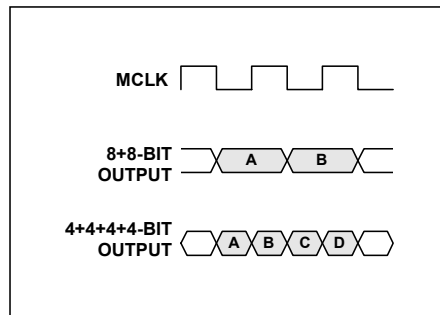

**Figure 17 Output Data Formats (Modes 1 – 2, 4 – 6)**

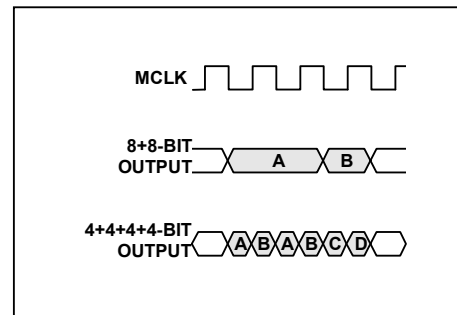

**Figure 18 Output Data Formats (Mode 3)**

OUTPUT FORMAT	MUXOP[1:0]	OUTPUT PINS	OUTPUT
8+8-bit multiplexed	00, 01, 10	OP[7:0]	A = d15, d14, d13, d12, d11, d10, d9, d8 B = d7, d6, d5, d4, d3, d2, d1, d0
4+4+4+4-bit (nibble)	11	OP[7:4]	A = d15, d14, d13, d12 B = d11, d10, d9, d8 C = d7, d6, d5, d4 D = d3, d2, d1, d0

**Table 2 Details of Output Data Shown in Figure 17 and Figure 18.**

## CONTROL INTERFACE

The internal control registers are programmable via the serial digital control interface. The register contents can be read back via the serial interface on pin OP[7]/SDO.

Note: It is recommended that a software reset is carried out after the power-up sequence, before writing to any other register. This ensures that all registers are set to their default values (as shown in Table 6).

### SERIAL INTERFACE: REGISTER WRITE

Figure 19 shows register writing in serial mode. Three pins, SCK, SDI and SEN are used. A six-bit address (a5, 0, a3, a2, a1, a0) is clocked in through SDI, MSB first, followed by an eight-bit data word (b7, b6, b5, b4, b3, b2, b1, b0), also MSB first. Each bit is latched on the rising edge of SCK. When the data has been shifted into the device, a pulse is applied to SEN to transfer the data to the appropriate internal register. Note all valid registers have address bit a4 equal to 0 in write mode.

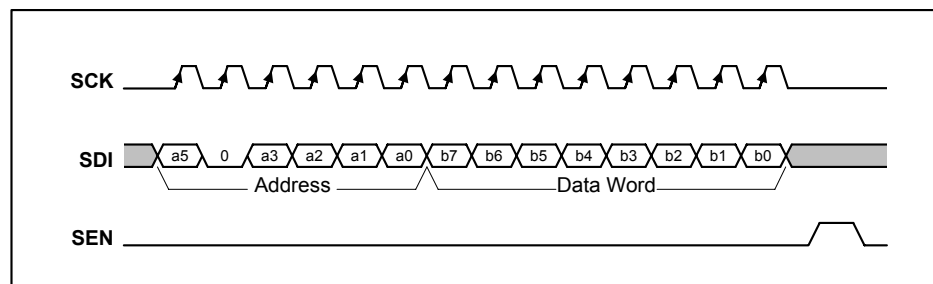

Figure 19 Serial Interface Register Write

A software reset is carried out by writing to Address "000100" with any value of data, (i.e. Data Word = XXXXXXXX).

### SERIAL INTERFACE: REGISTER READ-BACK

Figure 20 shows register read-back in serial mode. Read-back is initiated by writing to the serial bus as described above but with address bit a4 set to 1, followed by an 8-bit dummy data word. Writing address (a5, 1, a3, a2, a1, a0) will cause the contents (d7, d6, d5, d4, d3, d2, d1, d0) of corresponding register (a5, 0, a3, a2, a1, a0) to be output MSB first on pin SDO (on the falling edge of SCK). Note that pin SDO is shared with an output pin, OP[7], therefore OEB should always be held low when register read-back data is expected on this pin. The next word may be read in to SDI while the previous word is still being output on SDO.

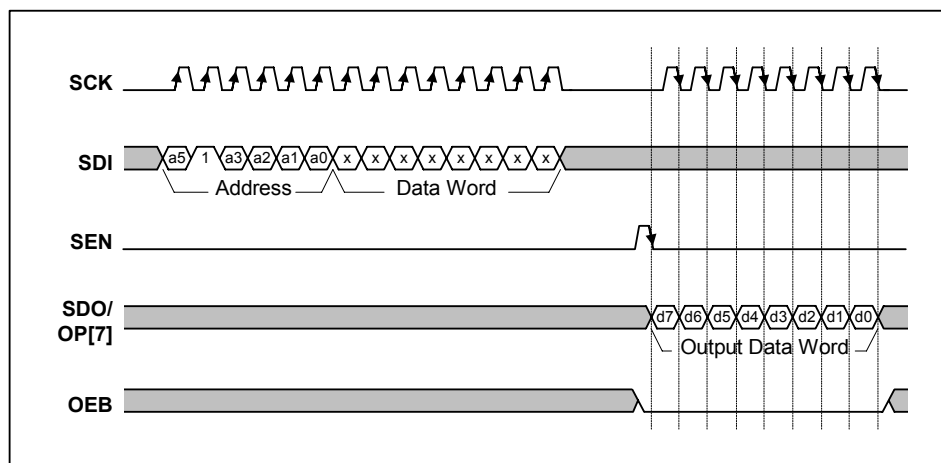

Figure 20 Serial Interface Register Read-back

## TIMING REQUIREMENTS

To use this device a master clock (MCLK) of up to 40MHz and a per-pixel synchronisation clock (VSMP) of up to 20MHz are required. These clocks drive a timing control block, which produces internal signals to control the sampling of the video signal. MCLK to VSMP ratios and maximum sample rates for the various modes are shown in Table 5.

## PROGRAMMABLE VSMP DETECT CIRCUIT

The VSMP input is used to determine the sampling point and frequency of the WM8199. Under normal operation a pulse of 1 MCLK period should be applied to VSMP at the desired sampling frequency (as shown in the Operating Mode Timing Diagrams) and the input sample will be taken on the first rising MCLK edge after VSMP has gone low. However, in certain applications such a signal may not be readily available. The programmable VSMP detect circuit in the WM8199 allows the sampling point to be derived from any signal of the correct frequency, such as a CCD shift register clock, when applied to the VSMP pin.

When enabled, by setting the VSMPDET control bit, the circuit detects either a rising or falling edge (determined by POSNNEG control bit) on the VSMP input pin and generates an internal VSMP pulse. This pulse can optionally be delayed by a number of MCLK periods, specified by the VDEL[2:0] bits. Figure 21 shows the internal VSMP pulses that can be generated by this circuit for a typical clock input signal. The internal VSMP pulse is then applied to the timing control block in place of the normal VSMP pulse provided from the input pin. The sampling point then occurs on the first rising MCLK edge after this internal VSMP pulse, as shown in the Operating Mode Timing Diagrams.

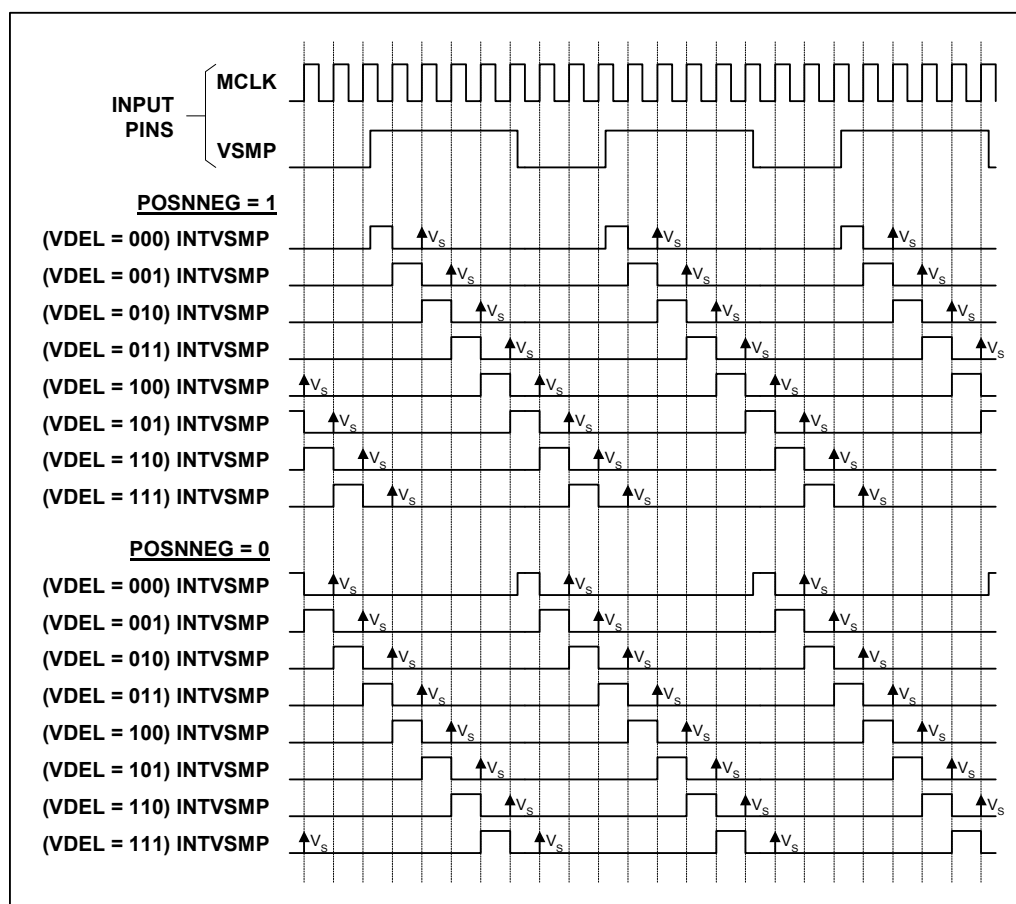

Figure 21 Internal VSMP Pulses Generated by Programmable VSMP Detect Circuit

## REFERENCES

The ADC reference voltages are derived from an internal bandgap reference, and buffered to pins VRT and VRB, where they must be decoupled to ground. Pin VRX is driven by a similar buffer, and also requires decoupling. The output buffer from the RLCDAC also requires decoupling at pin VRLC/VBIAS

## POWER SUPPLY

The WM8199 can run from a 5V single supply or from split 5V (core) and 3.3V (digital interface) supplies.

## POWER MANAGEMENT

Power management for the device is performed via the Control Interface. The device can be powered on or off completely by setting the EN bit and SELPD bit low. Alternatively, when control bit SELPD is high, only blocks selected by further control bits (SELDIS[3:0]) are powered down. This allows the user to optimise power dissipation in certain modes, or to define an intermediate standby mode to allow a quicker recovery into a fully active state. In Line-by-line operation, the green and blue channel PGAs are automatically powered down.

All the internal registers maintain their previously programmed value in power down modes and the Control Interface inputs remain active. Table 3 summarises the power down control bit functions.

EN	SELPD	
0	0	Device completely powers down.
1	0	Device completely powers up.
X	1	Blocks with respective SELDIS[3:0] bit high are disabled.

Table 3 Power Down Control

## LINE-BY-LINE OPERATION

Certain linear sensors (e.g. Contact Image Sensors) give colour output on a line-by-line basis. i.e. a full line of red pixels followed by a line of green pixels followed by a line of blue pixels. In order to accommodate this type of signal the WM8199 can be set into Monochrome mode, with the input channel switched by writing to control bits CHAN[1:0] between every line. Alternatively, the WM8199 can be placed into colour line-by-line mode by setting the LINEBYLINE control bit. When this bit is set the green and blue processing channels are powered down and the device is forced internally to only operate in MONO mode (because only one colour is sampled at a time) through the red channel. Figure 22 shows the signal path when operating in colour line-by-line mode.

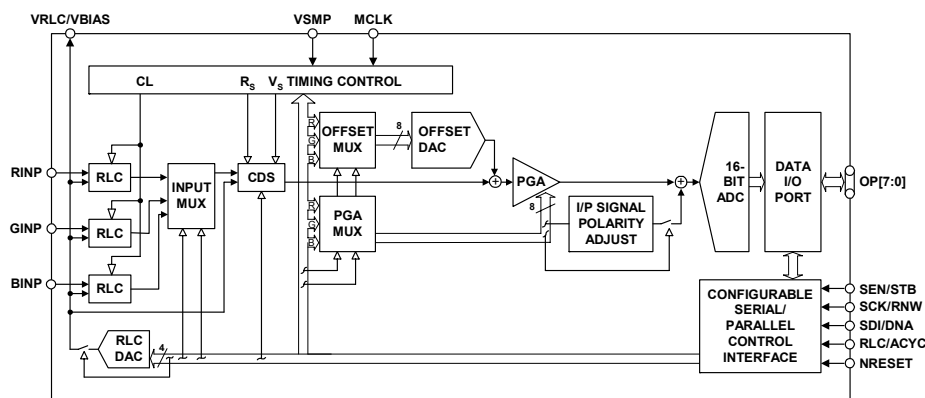

Figure 22 Signal Path When in Line-by-Line Mode

In this mode the input multiplexer and (optionally) the PGA/Offset register multiplexers can be auto-cycled by the application of pulses to the RLC/ACYC input pin by setting the ACYCNRLC register bit. See figure 4 for detailed timing. The multiplexers change on the first MCLK rising edge after RLC/ACYC is taken high. A write to the auto-cycle reset register causes these multiplexers to be reset; selecting the RINP pin and the RED offset/gain registers. Alternatively, all three multiplexers can be controlled via the serial interface by writing to register bits INTM[1:0] to select the desired colour. It is also possible for the input multiplexer to be controlled separately from the PGA and Offset multiplexers. Table 4 describes all the multiplexer selection modes that are possible.

FME	ACYCNRLC	NAME	DESCRIPTION
0	0	Internal, no force mux	Input mux, offset and gain registers determined by internal register bits INTM1, INTM0.
0	1	Auto-cycling, no force mux	Input mux, offset and gain registers auto-cycled, RINP → GINP → BINP → RINP... on RLC/ACYC pulse.
1	0	Internal, force mux	Input mux selected from internal register bits FM1, FM0; Offset and gain registers selected from internal register bits INTM1, INTM0.
1	1	Auto-cycling, force mux	Input mux selected from internal register bits FM1, FM0; Offset and gain registers auto-cycled, RED → GREEN → BLUE → RED... on RLC/ACYC pulse.

Table 4 Colour Selection Description in Line-by-Line Mode

## OPERATING MODES

Table 5 summarises the most commonly used modes, the clock waveforms required and the register contents required for CDS and non-CDS operation.

MODE	DESCRIPTION	CDS AVAILABLE	MAX SAMPLE RATE	SENSOR INTERFACE DESCRIPTION	TIMING REQUIREMENTS	REGISTER CONTENTS WITH CDS	REGISTER CONTENTS WITHOUT CDS
1	Colour Pixel-by-Pixel	Yes	6.67MSPS	The 3 input channels are sampled in parallel. The signal is then gain and offset adjusted before being multiplexed into a single data stream and converted by the ADC, giving an output data rate of 20MSPS max.	MCLK max = 40MHz MCLK: VSMP ratio is 6:1	SetReg1: 03(hex)	SetReg1: 01(hex)
2	Monochrome/ Colour Line-by-Line	Yes	6.67MSPS	As mode 1 except: Only one input channel at a time is continuously sampled.	MCLK max = 40MHz MCLK: VSMP ratio is 6:1	SetReg1: 07(hex)	SetReg1: 05(hex)
3	Fast Monochrome/ Colour Line-by-Line	Yes	13.33MSPS	Identical to mode 2	MCLK max = 40MHz MCLK: VSMP ratio is 3:1	Identical to mode 2 plus SetReg3: bits 5:4 must be set to 0(hex)	Identical to mode 2
4	Maximum speed Monochrome/ Colour Line-by-Line	No	20MSPS	Identical to mode 2	MCLK max = 40MHz MCLK: VSMP ratio is 2:1	CDS not possible	SetReg1: 45(hex)
5	Slow Colour Pixel-by-Pixel	Yes	5MSPS	Identical to mode 1	MCLK max = 40MHz MCLK: VSMP ratio is 2n:1, n ≥ 4	Identical to mode 1	Identical to mode 1
6	Slow Monochrome/ Colour Line-by-Line	Yes	5MSPS	Identical to mode 2	MCLK max = 40MHz MCLK: VSMP ratio is 2n:1, n ≥ 4	Identical to mode 2	Identical to mode 2

**Table 5 WM8199 Operating Modes**

### Notes:

1. In Monochrome mode, SetReg3 bits 7:6 determine which input is to be sampled.
2. For Colour Line-by-Line, set control bit LINEBYLINE. For input selection, refer to Table 4, Colour Selection Description in Line-by-Line Mode.

**OPERATING MODE TIMING DIAGRAMS**

The following diagrams show 8-bit multiplexed output data and MCLK, VSMP and input video requirements for operation of the most commonly used modes as shown in Table 5. The diagrams are identical for both CDS and non-CDS operation. Outputs from RINP, GINP and BINP are shown as R, G and B respectively. X denotes invalid data.

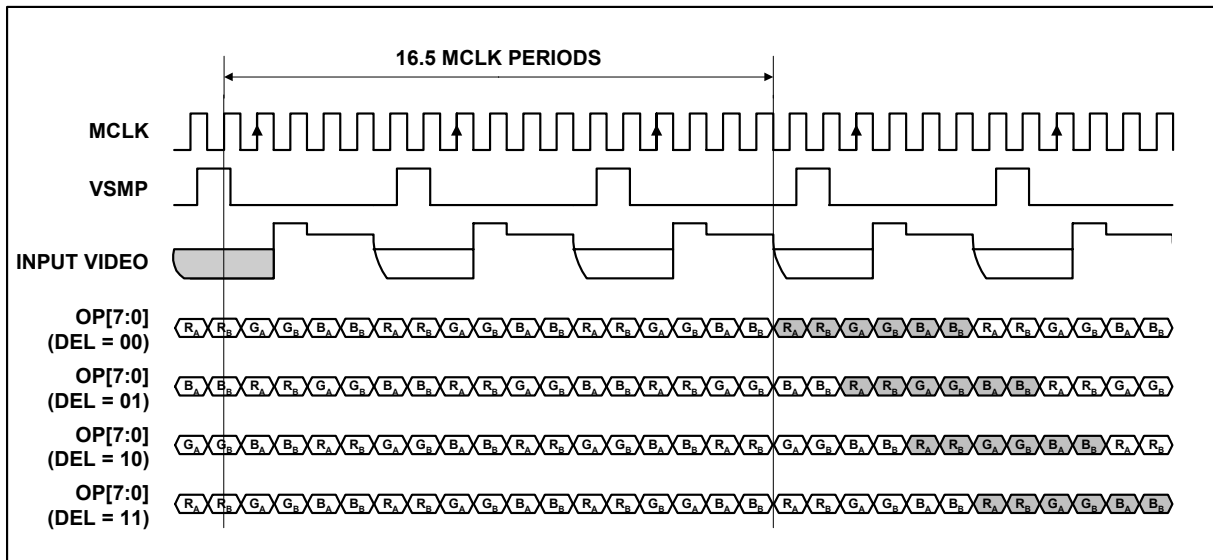

Figure 23 Mode 1 Operation

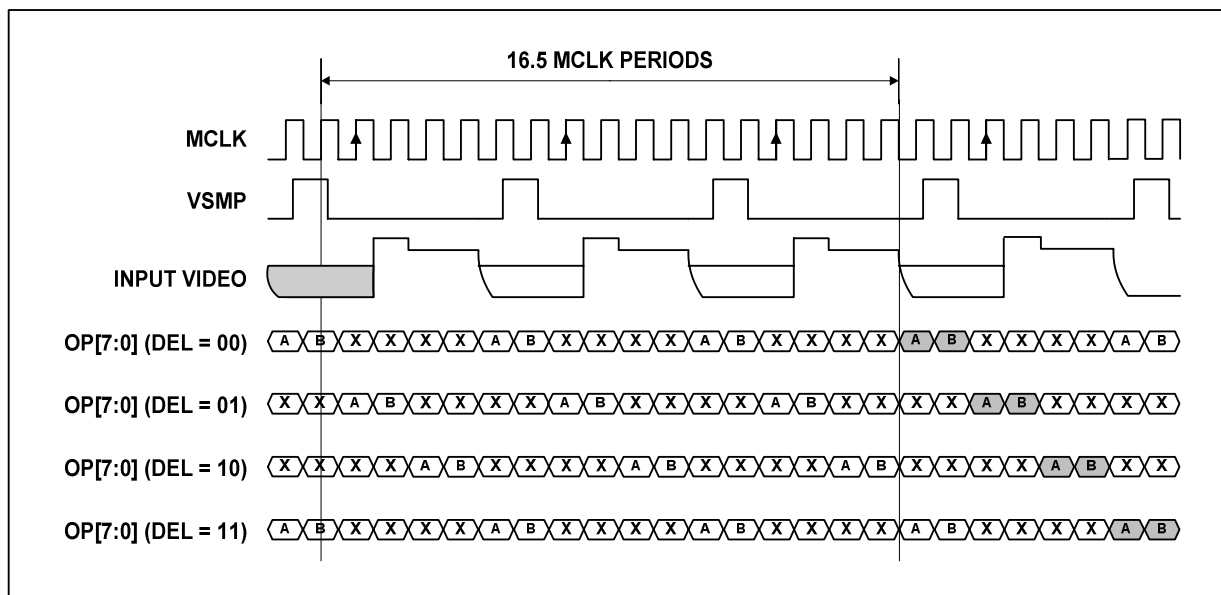

Figure 24 Mode 2 Operation

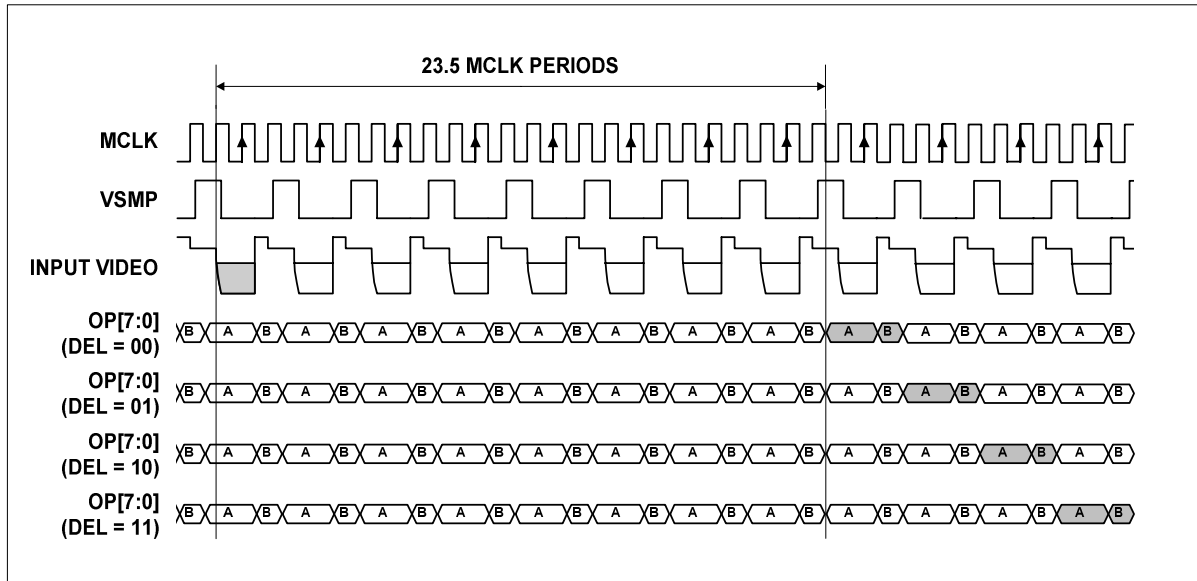

Figure 25 Mode 3 Operation

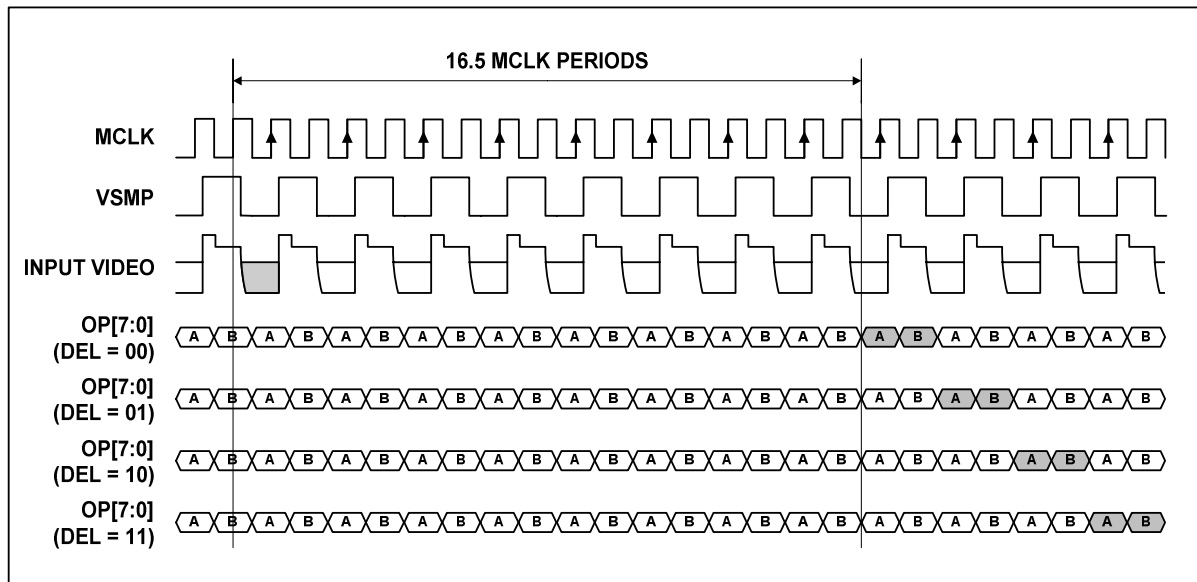

Figure 26 Mode 4 Operation



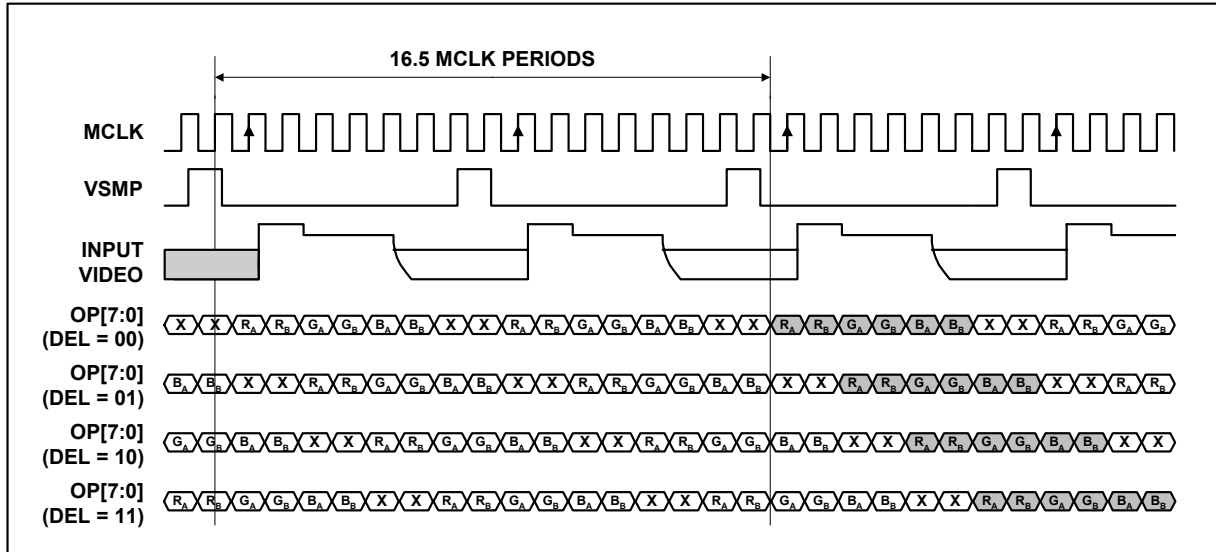

Figure 27 Mode 5 Operation (MCLK:VSMP Ratio = 8:1)

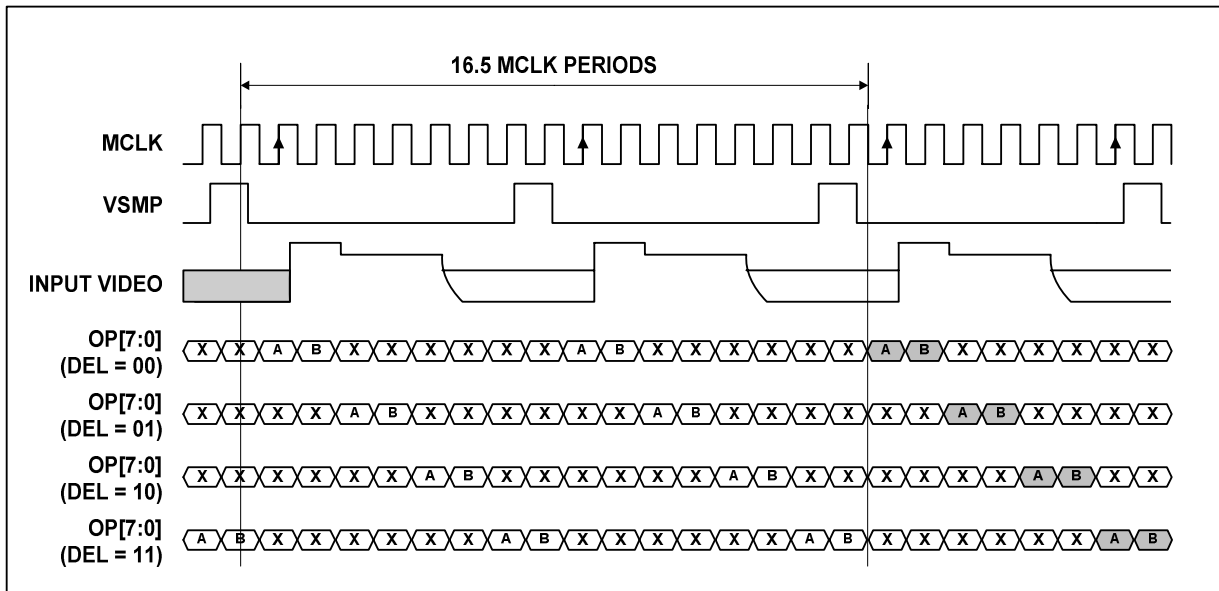

Figure 28 Mode 6 Operation (MCLK:VSMP Ratio = 8:1)

## DEVICE CONFIGURATION

### REGISTER MAP

The following table describes the location of each control bit used to determine the operation of the WM8199. The register map is programmed by writing the required codes to the appropriate addresses via the serial interface.

ADDRESS <a5:a0>	DESCRIPTION	DEF (hex)	RW	BIT							
				b7	b6	b5	b4	b3	b2	b1	b0
000001	Setup Reg 1	03	RW	0	MODE4	PGAFS[1]	PGAFS[0]	SELPD	MONO	CDS	EN
000010	Setup Reg 2	20	RW	DEL[1]	DEL[0]	RLCDACRNG	0	VRLCEXT	INVOP	MUXOP[1]	MUXOP[0]
000011	Setup Reg 3	1F	RW	CHAN[1]	CHAN[0]	CDSREF [1]	CDSREF [0]	RLCV[3]	RLCV[2]	RLCV[1]	RLCV[0]
000100	Software Reset	00	W								
000101	Auto-cycle Reset	00	W								
000110	Setup Reg 4	00	RW	FM[1]	FM[0]	INTM[1]	INTM[0]	RLCINT	FME	ACYCNRLC	LINEBYLINE
000111	Revision Number	41	R								
001000	Setup Reg 5	00	RW	0	0	0	POSNNEG	VDEL[2]	VDEL[1]	VDEL[0]	VSMPDET
001001	Setup Reg 6	00	RW	0	0	0	0	SELDIS[3]	SELDIS[2]	SELDIS[1]	SELDIS[0]
001010	Reserved	00	RW	0	0	0	0	0	0	0	0
001011	Reserved	00	RW	0	0	0	0	0	0	0	0
001100	Reserved	00	RW	0	0	0	0	0	0	0	0
100000	DAC Value (Red)	80	RW	DAC[7]	DAC[6]	DAC[5]	DAC[4]	DAC[3]	DAC[2]	DAC[1]	DAC[0]
100001	DAC Value (Green)	80	RW	DAC[7]	DAC[6]	DAC[5]	DAC[4]	DAC[3]	DAC[2]	DAC[1]	DAC[0]
100010	DAC Value (Blue)	80	RW	DAC[7]	DAC[6]	DAC[5]	DAC[4]	DAC[3]	DAC[2]	DAC[1]	DAC[0]
100011	DAC Value (RGB)	80	W	DAC[7]	DAC[6]	DAC[5]	DAC[4]	DAC[3]	DAC[2]	DAC[1]	DAC[0]
101000	PGA Gain (Red)	00	RW	PGA[7]	PGA[6]	PGA[5]	PGA[4]	PGA[3]	PGA[2]	PGA[1]	PGA[0]
101001	PGA Gain (Green)	00	RW	PGA[7]	PGA[6]	PGA[5]	PGA[4]	PGA[3]	PGA[2]	PGA[1]	PGA[0]
101010	PGA Gain (Blue)	00	RW	PGA[7]	PGA[6]	PGA[5]	PGA[4]	PGA[3]	PGA[2]	PGA[1]	PGA[0]
101011	PGA Gain (RGB)	00	W	PGA[7]	PGA[6]	PGA[5]	PGA[4]	PGA[3]	PGA[2]	PGA[1]	PGA[0]

**Table 6 Register Map**

## REGISTER MAP DESCRIPTION

The following table describes the function of each of the control bits shown in Table 6.

REGISTER	BIT NO	BIT NAME(S)	DEFAULT	DESCRIPTION
Setup Register 1	0	EN	1	When SELPD = 1 this bit has no effect. When SELPD = 0 this bit controls the global power down: 0 = complete power down, 1 = fully active.
	1	CDS	1	Select correlated double sampling mode: 0 = single ended mode, 1 = CDS mode.
	2	MONO	0	Mono/colour select: 0 = colour, 1 = monochrome operation.
	3	SELPD	0	Selective power down: 0 = no individual control, 1 = individual blocks can be disabled (controlled by SELDIS[3:0]).
	5:4	PGAFS[1:0]	00	Offsets PGA output to optimise the ADC range for different polarity sensor output signals. Zero differential PGA input signal gives: 00 = Zero output 01 = Zero output 10 = Full-scale positive output (use for negative going video) 11 = Full-scale negative output (use for positive going video)
	6	MODE4	0	Required when operating in MODE4: 0 = other modes, 1 = MODE4.
	7	Reserved	0	Must be set to zero
Setup Register 2	1:0	MUXOP[1:0]	00	Determines the output data format. 00 = 8-bit multiplexed 01 = 8-bit multiplexed (8+8 bits) 10 = 8-bit multiplexed mode (8+8 bits) 11 = 4-bit multiplexed mode (4+4+4+4 bits)
	2	INVOP	0	Digitally inverts the polarity of output data. 0 = negative going video gives negative going output, 1 = negative-going video gives positive going output data.
	3	VRLCEXT	0	When set powers down the RLCDAC, changing its output to Hi-Z, allowing VRLC/VBIAS to be externally driven.
	5	RLCDACRNG	1	Sets the output range of the RLCDAC. 0 = RLCDAC ranges from 0 to AVDD (approximately), 1 = RLCDAC ranges from 0 to VRT (approximately).
	7:6	DEL[1:0]	00	Sets the output latency in ADC clock periods. 1 ADC clock period = 2 MCLK periods except in Mode 3 where 1 ADC clock period = 3 MCLK periods. 00 = Minimum latency 01 = Delay by one ADC clock 10 = Delay by two ADC clock periods 11 = Delay by three ADC clock periods
Setup Register 3	3:0	RLCV[3:0]	1111	Controls RLCDAC driving VRLC pin to define single ended signal reference voltage or Reset Level Clamp voltage. See Electrical Characteristics section for ranges.
	5:4	CDSREF[1:0]	01	CDS mode reset timing adjust. 00 = Advance 1 MCLK period 01 = Normal 10 = Retard 1 MCLK period 11 = Retard 2 MCLK periods
	7:6	CHAN[1:0]	00	Monochrome mode channel select. 00 = Red channel select 01 = Green channel select 10 = Blue channel select 11 = Reserved
Software Reset			Any write to Software Reset causes all cells to be reset. It is recommended that a software reset be performed after a power-up before any other register writes.	
Auto-cycle Reset			Any write to Auto-cycle Reset causes the auto-cycle counter to reset to RINP. This function is only required when LINEBYLINE = 1.	

REGISTER	BIT NO	BIT NAME(S)	DEFAULT	DESCRIPTION
Setup Register 4	0	LINEBYLINE	0	Selects line by line operation 0 = normal operation, 1 = line by line operation. When line by line operation is selected MONO is forced to 1 and CHAN[1:0] to 00 internally, ensuring that the correct internal timing signals are produced. Green and Blue PGAs are also disabled to save power.
	1	ACYCNRLC	0	When LINEBYLINE = 0 this bit has no effect. When LINEBYLINE = 1 this bit determines the function of the RLC/ACYC input pin and the input multiplexer and offset/gain register controls. 0 = RLC/ACYC pin enabled for Reset Level Clamp. Internal selection of input and gain/offset multiplexers, 1 = Auto-cycling enabled by pulsing the RLC/ACYC input pin. See Table 4, Colour Selection Description in Line-by-Line Mode for colour selection mode details. When auto-cycling is enabled, the RLC/ACYC pin cannot be used for reset level clamping. The RLCINT bit may be used instead.
	2	FME	0	When LINEBYLINE = 0 this bit has no effect. When LINEBYLINE = 1 this bit controls the input force mux mode: 0 = No force mux, 1 = Force mux mode. Forces the input mux to be selected by FM[1:0] separately from gain and offset multiplexers. See Table 4 for details.
	3	RLCINT	0	When LINEBYLINE = 1 and ACYCNRLC = 1 this bit is used to determine whether Reset Level Clamping is used. 0 = RLC disabled, 1 = RLC enabled.
	5:4	INTM[1:0]	00	Colour selection bits used in internal modes. 00 = Red, 01 = Green, 10 = Blue and 11 = Reserved. See Table 4 for details.
	7:6	FM[1:0]	00	Colour selection bits used in input force mux modes. 00 = RINP, 01 = GINP, 10 = BINP and 11 = Reserved. See Table 4 for details.
Setup Register 5	0	VSMPDET	0	0 = Normal operation, signal on VSMP input pin is applied directly to Timing Control block. 1 = Programmable VSMP detect circuit is enabled. An internal synchronisation pulse is generated from signal applied to VSMP input pin and is applied to Timing Control block.
	3:1	VDEL[2:0]	000	When VSMPDET = 0 these bits have no effect. When VSMPDET = 1 these bits set a programmable delay from the detected edge of the signal applied to the VSMP pin. The internally generated pulse is delayed by VDEL MCLK periods from the detected edge. See Figure 21, Internal VSMP Pulses Generated for details.
	4	POSNEG	0	When VSMPDET = 0 this bit has no effect. When VSMPDET = 1 this bit controls whether positive or negative edges are detected: 0 = Negative edge on VSMP pin is detected and used to generate internal timing pulse. 1 = Positive edge on VSMP pin is detected and used to generate internal timing pulse. See Figure 21 for further details.
	7:5	Reserved	000	Must be set to zero
Setup Register 6	3:0	SELDIS[3:0]	0000	Selective power disable register - activated when SELPD = 1. Each bit disables respective cell when 1, enabled when 0. SELDIS[0] = Red CDS, PGA SELDIS[1] = Green CDS, PGA SELDIS[2] = Blue CDS, PGA SELDIS[3] = ADC
	7:4	Reserved	0000	Must be set to zero

REGISTER	BIT NO	BIT NAME(S)	DEFAULT	DESCRIPTION
Offset DAC (Red)	7:0	DAC[7:0]	00000000	Red channel offset DAC value.
Offset DAC (Green)	7:0	DAC[7:0]	00000000	Green channel offset DAC value
Offset DAC (Blue)	7:0	DAC[7:0]	00000000	Blue channel offset DAC value
Offset DAC (RGB)	7:0	DAC[7:0]	00000000	A write to this register location causes the red, green and blue offset DAC registers to be overwritten by the new value
PGA gain (Red)	7:0	PGA[7:0]	00000000	Determines the gain of the red channel PGA according to the equation: Red channel PGA gain = $208/(283-PGA[7:0])$
PGA gain (Green)	7:0	PGA[7:0]	00000000	Determines the gain of the green channel PGA according to the equation: Green channel PGA gain = $208/(283-PGA[7:0])$
PGA gain (Blue)	7:0	PGA[7:0]	00000000	Determines the gain of the blue channel PGA according to the equation: Blue channel PGA gain = $208/(283-PGA[7:0])$
PGA gain (RGB)	7:0	PGA[7:0]	00000000	A write to this register location causes the red, green and blue PGA gain registers to be overwritten by the new value

Table 7 Register Control Bits

RECOMMENDED EXTERNAL COMPONENTS

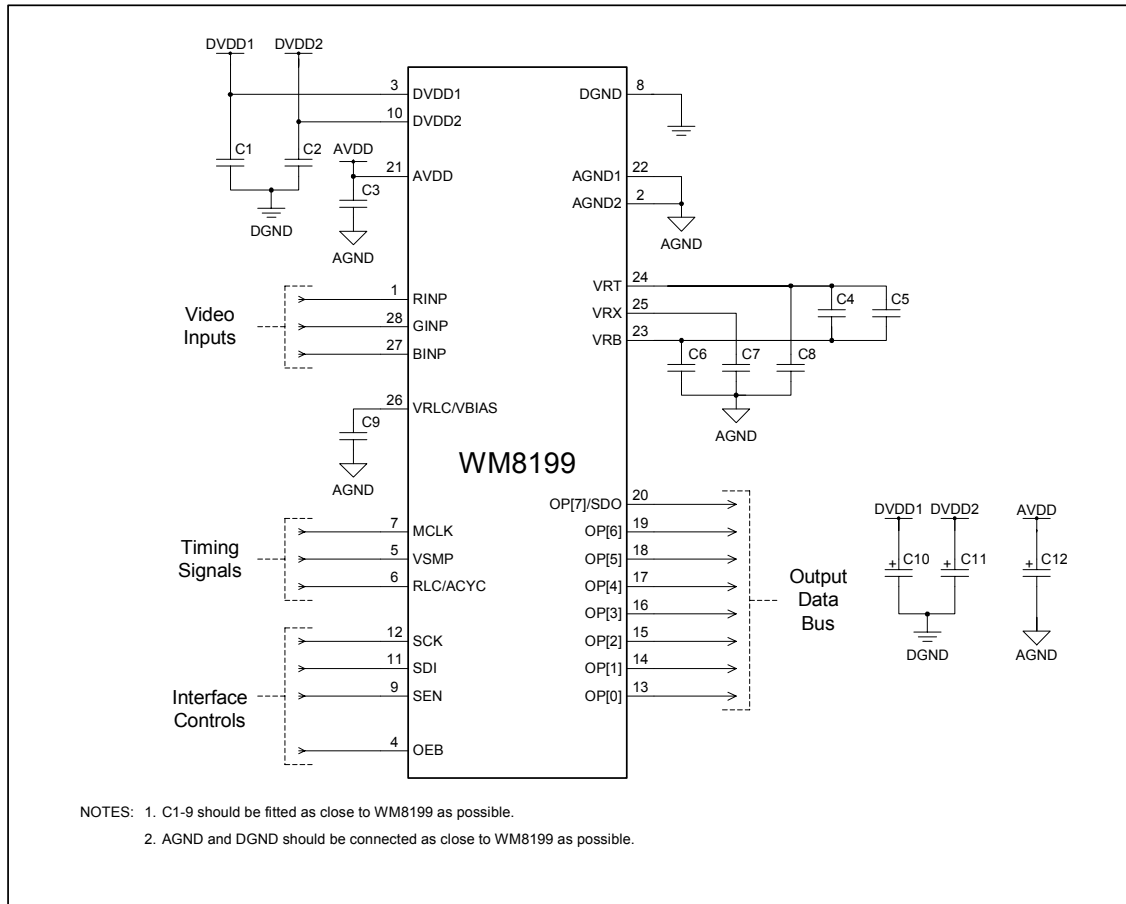
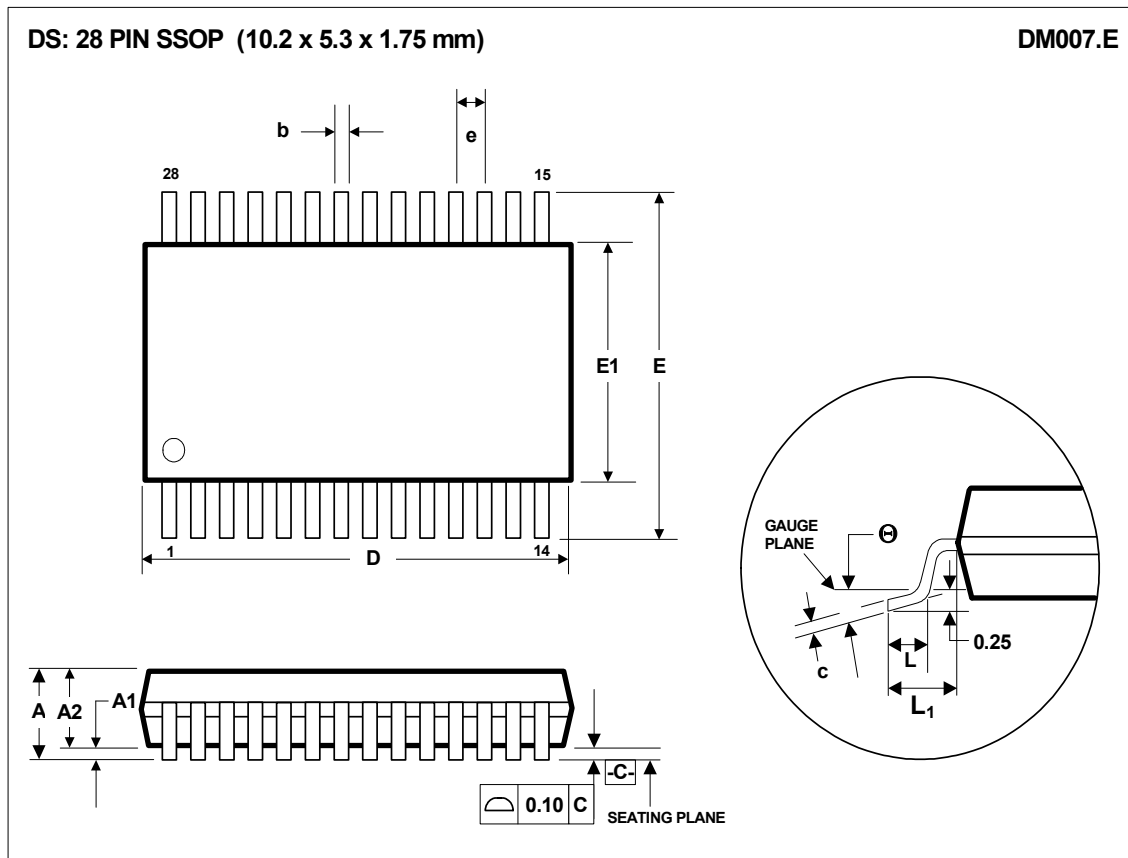

Figure 29 External Components Diagram

COMPONENT REFERENCE	SUGGESTED VALUE	DESCRIPTION
C1	100nF	De-coupling for DVDD1.
C2	100nF	De-coupling for DVDD2.
C3	100nF	De-coupling for AVDD.
C4	10nF	High frequency de-coupling between VRT and VRB.
C5	1µF	Low frequency de-coupling between VRT and VRB (non-polarised).
C6	100nF	De-coupling for VRB.
C7	100nF	De-coupling for VRX.
C8	100nF	De-coupling for VRT.
C9	100nF	De-coupling for VRLC.
C10	10µF	Reservoir capacitor for DVDD1.
C11	10µF	Reservoir capacitor for DVDD2.
C12	10µF	Reservoir capacitor for AVDD.

Table 8 External Components Descriptions

PACKAGE DIMENSIONS



Symbols	Dimensions (mm)		
	MIN	NOM	MAX
<b>A</b>	----	----	2.0
<b>A<sub>1</sub></b>	0.05	----	0.25
<b>A<sub>2</sub></b>	1.65	1.75	1.85
<b>b</b>	0.22	0.30	0.38
<b>c</b>	0.09	----	0.25
<b>D</b>	9.90	10.20	10.50
<b>e</b>	0.65 BSC		
<b>E</b>	7.40	7.80	8.20
<b>E<sub>1</sub></b>	5.00	5.30	5.60
<b>L</b>	0.55	0.75	0.95
<b>L<sub>1</sub></b>	1.25 REF		
<b>θ</b>	0°	4°	8°
<b>REF:</b>	JEDEC.95, MO-150		

- NOTES:  
 A. ALL LINEAR DIMENSIONS ARE IN MILLIMETERS.  
 B. THIS DRAWING IS SUBJECT TO CHANGE WITHOUT NOTICE.  
 C. BODY DIMENSIONS DO NOT INCLUDE MOLD FLASH OR PROTRUSION, NOT TO EXCEED 0.20MM.  
 D. MEETS JEDEC.95 MO-150, VARIATION = AH. REFER TO THIS SPECIFICATION FOR FURTHER DETAILS.

## IMPORTANT NOTICE

Wolfson Microelectronics plc ("Wolfson") products and services are sold subject to Wolfson's terms and conditions of sale, delivery and payment supplied at the time of order acknowledgement.

Wolfson warrants performance of its products to the specifications in effect at the date of shipment. Wolfson reserves the right to make changes to its products and specifications or to discontinue any product or service without notice. Customers should therefore obtain the latest version of relevant information from Wolfson to verify that the information is current.

Testing and other quality control techniques are utilised to the extent Wolfson deems necessary to support its warranty. Specific testing of all parameters of each device is not necessarily performed unless required by law or regulation.

In order to minimise risks associated with customer applications, the customer must use adequate design and operating safeguards to minimise inherent or procedural hazards. Wolfson is not liable for applications assistance or customer product design. The customer is solely responsible for its selection and use of Wolfson products. Wolfson is not liable for such selection or use nor for use of any circuitry other than circuitry entirely embodied in a Wolfson product.

Wolfson's products are not intended for use in life support systems, appliances, nuclear systems or systems where malfunction can reasonably be expected to result in personal injury, death or severe property or environmental damage. Any use of products by the customer for such purposes is at the customer's own risk.

Wolfson does not grant any licence (express or implied) under any patent right, copyright, mask work right or other intellectual property right of Wolfson covering or relating to any combination, machine, or process in which its products or services might be or are used. Any provision or publication of any third party's products or services does not constitute Wolfson's approval, licence, warranty or endorsement thereof. Any third party trade marks contained in this document belong to the respective third party owner.

Reproduction of information from Wolfson datasheets is permissible only if reproduction is without alteration and is accompanied by all associated copyright, proprietary and other notices (including this notice) and conditions. Wolfson is not liable for any unauthorised alteration of such information or for any reliance placed thereon.

Any representations made, warranties given, and/or liabilities accepted by any person which differ from those contained in this datasheet or in Wolfson's standard terms and conditions of sale, delivery and payment are made, given and/or accepted at that person's own risk. Wolfson is not liable for any such representations, warranties or liabilities or for any reliance placed thereon by any person.

### ADDRESS:

Wolfson Microelectronics plc  
Westfield House  
26 Westfield Road  
Edinburgh  
EH11 2QB  
United Kingdom

Tel :: +44 (0)131 272 7000  
Fax :: +44 (0)131 272 7001  
Email :: sales@wolfsonmicro.com